



# 5 Ton GWD Cane Spreaders

Ground Wheel Drive

Home of Worldwide Quality Blending, Conveying, Tending, & Spreading Products!



#304 Stainless Steel or Powder Coated  
#409 Stainless Steel, Hopper

2" x 6" Mild Steel Tubing Frame, With Heavy Duty Corner Braces



Bolt Together Hopper to Frame

All Metal Press Wheel Manual Engagement

Single Spindle Design, with 6-Bolt Hubs

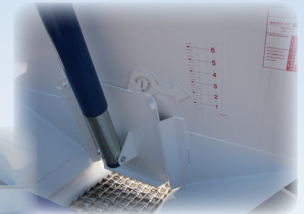
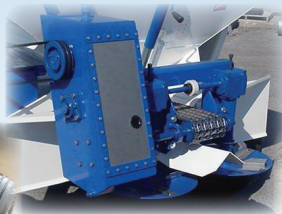

## Doyle Equipment Mfg. Co., Inc.

4001 Broadway, P.O. Box 3024, Quincy, IL 62305

Toll Free: 800-788-8085 Fax: 217-223-3655

E-mail: [doyle@doylemfg.com](mailto:doyle@doylemfg.com) Web Site: [www.doylemfg.com](http://www.doylemfg.com)

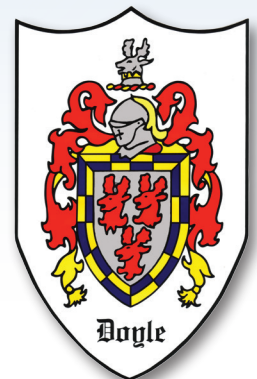

### Standard Features:

- 14 ga. 409 stainless steel hopper construction, all metal shot blasted and powder coated
- OR 14 ga. 304 stainless steel hopper construction
- 2" x 6" mild steel tubing frame, with heavy duty mild steel corner braces
- Bolt on hopper to frame, allows easy hopper removal from frame
- Heavy duty adjustable hitch
- 1" x 1" mesh type heavy duty 8" conveyor chain
- All metal press wheel with manual engagement
- Twin dished type spinners, 19-1/4" diameter with 4 adjustable stainless steel blades
- For 409 SS Hoppers - Main gearbox and spinner mount assemblies are mild steel, shot blasted, and powder coated bright blue
- For 304 SS Hoppers - Main gearbox and spinner mount assemblies are 304 stainless steel
- Heavy duty 8,000 lb. tongue jack
- Single spindle design, with 6-bolt hubs
- 12.5 L x 15 Hi-speed implement rib tires
- Mud tire and power wheel for mud tire
- Factory assembled & tested

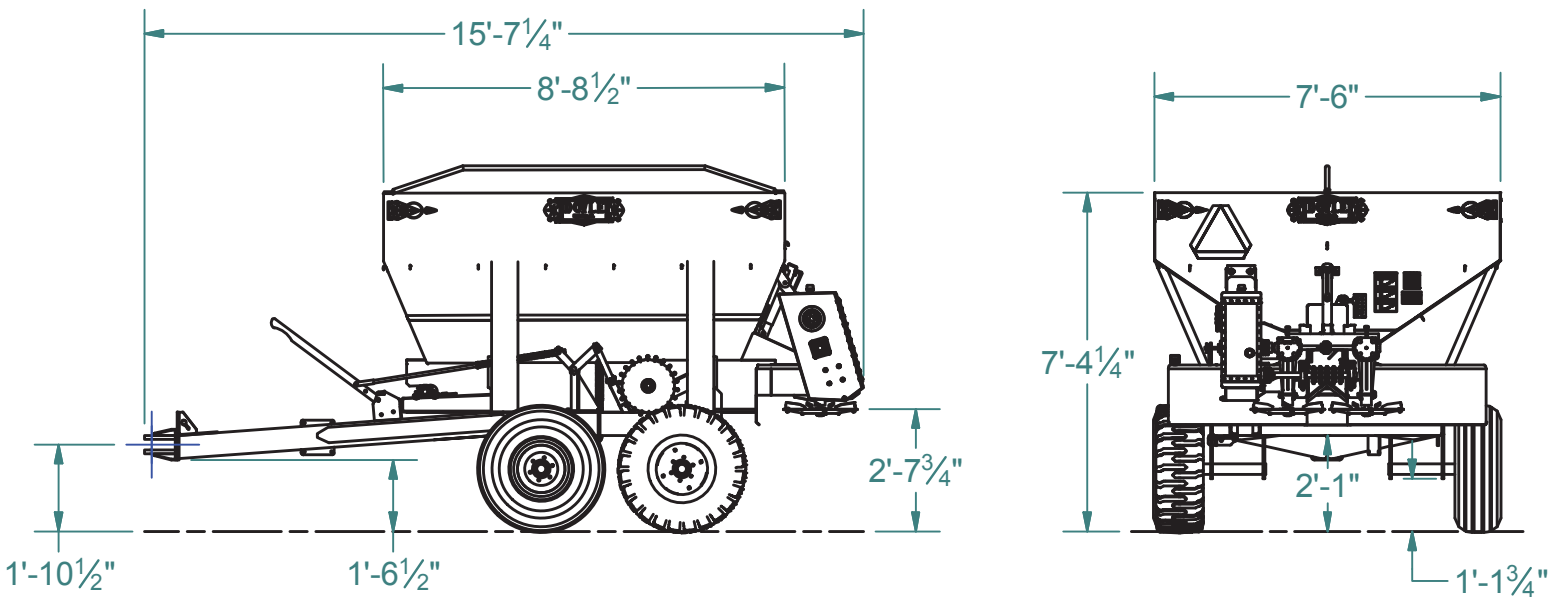

### Optional Features:

- Hydraulic press wheel engagement includes springs, cylinder, and hydraulic hoses
- Hydraulically driven spinner assembly, with flow control
- Fitted nylon tarp with grommets
- Roll Tarp

