

# CTS TRACTOR

## Reduce your compaction zones and increase traction

Engineered to easily convert tractors to tracks. With excellent traction and flotation in wet or soft ground conditions, it's a perfect choice for tillage and rice fields.

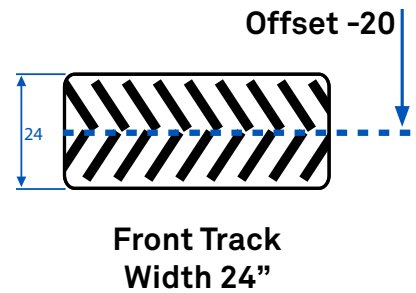
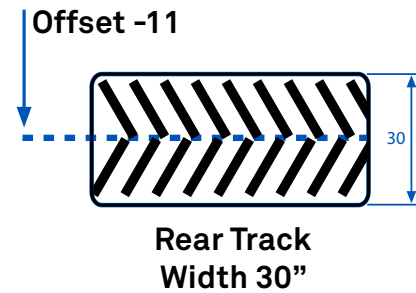

## Sprocket

To get the most power to the ground

- Positive drive sprocket designed to engage up to 8 drive lugs

## Main frames

Simplifies maintenance operations

- Oil bath drive hubs

## Suspension

Improves ground contact on uneven terrain to help transfer power to the ground

- Patented double oscillating bogie wheels

## Hydraulic tensioning system

Maximizes tractive performance hydraulic tensioning system with nitrogen-charged accumulator

- Maintains track tension for each system independently

## Track

Improves traction

- Designed with a large track footprint to reduce ground pressure and high traction tread pattern

## Wheels

Simplifies maintenance operations

- Heavy duty wheel hubs with oil bath lubrication
- No greasing or repacking of bearings

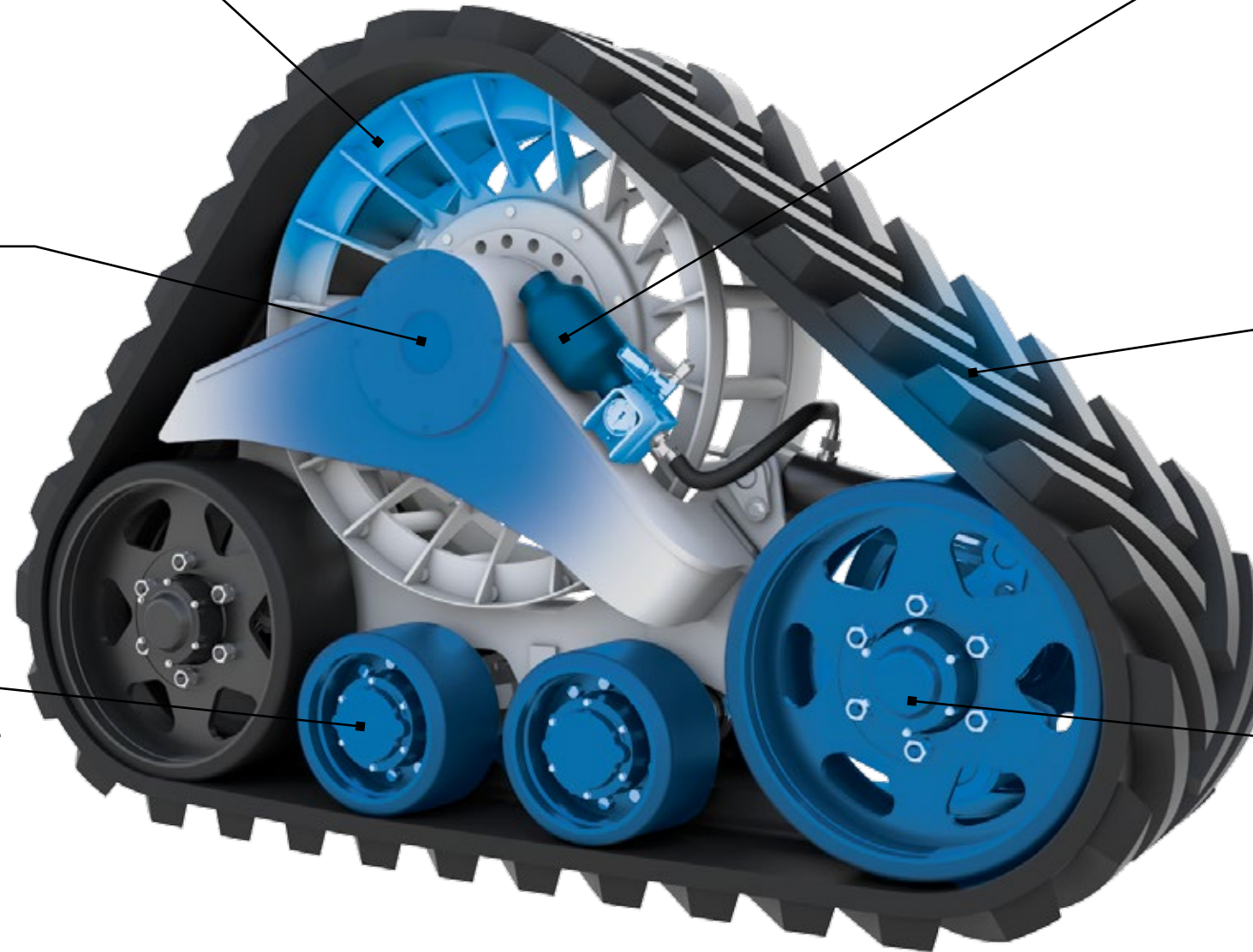

# CAMSO CTS TRACTOR

## TRACK SYSTEM FRONT

### 24D18C

Track width	24"
Track system height	53.8"
Track system length	82.1"
Flat plate area per pair (in <sup>2</sup> )	2,568

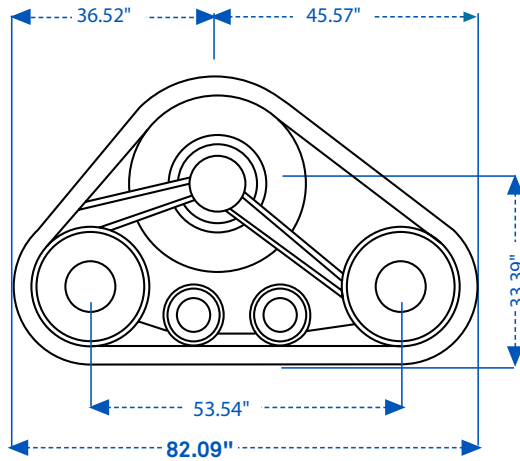

## TRACK SYSTEM REAR

### 30D23MC

Track width	30"
Track system height	64.6"
Track system length	85.2"
Flat plate area per pair (in <sup>2</sup> )	3,402

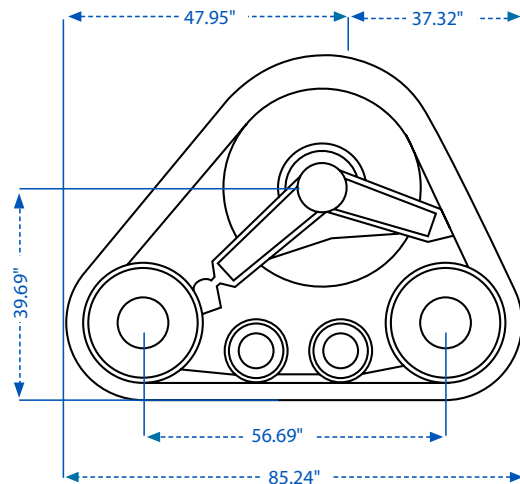

Camso provides comprehensive warranty coverage for a period of 12 months from date of purchase, for Conversion Track System (CTS) against defects in materials and workmanship. Some conditions apply. Refer to the warranty certificate for details. For more info, visit [camso.co/agriculture](https://camso.co/agriculture)