

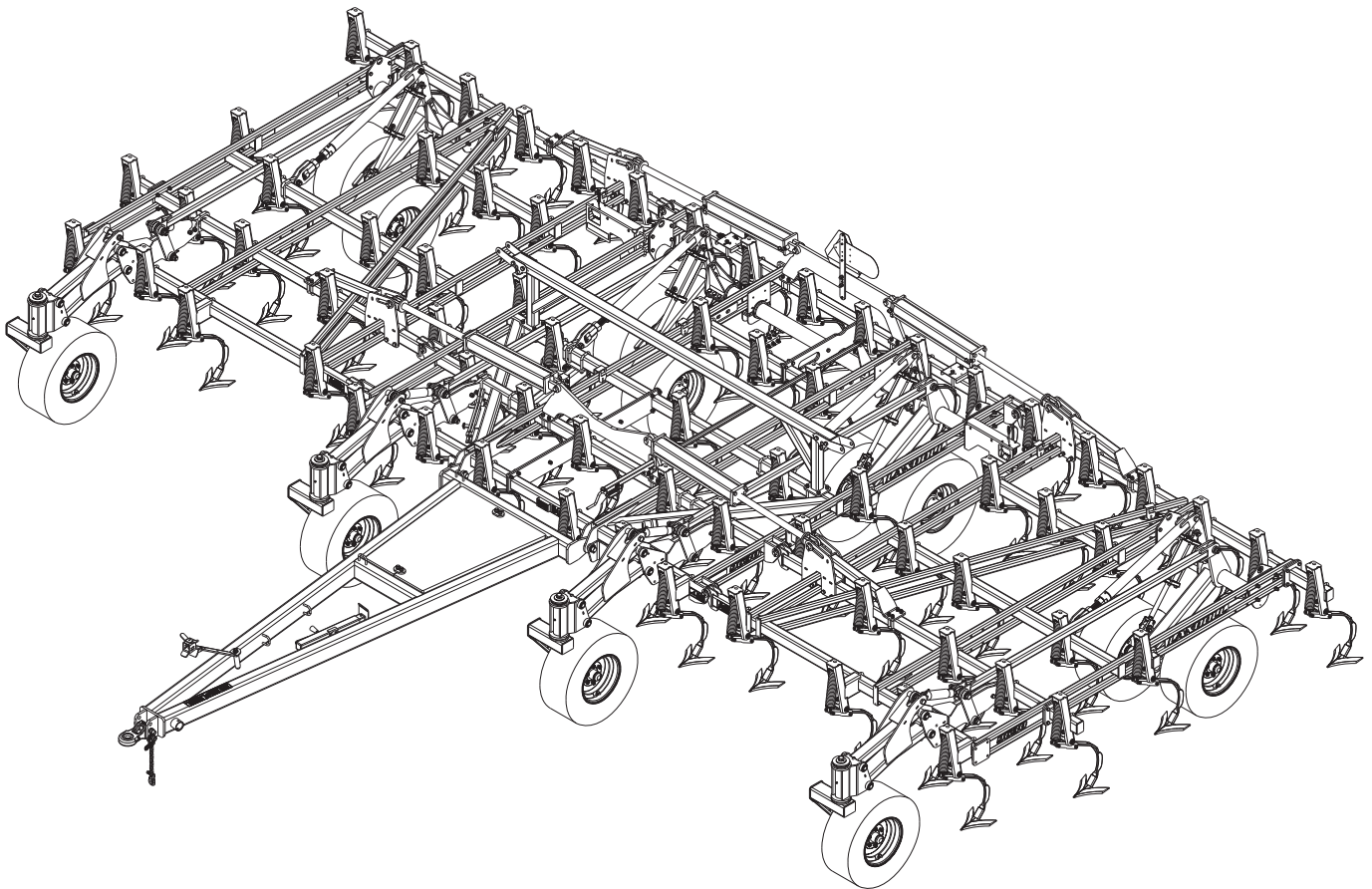

**Model 9630FH  
Field Cultivator  
Operator's Manual**



**LANDOLL COMPANY, LLC**

1900 North Street

Marysville, Kansas 66508

(785) 562-5381

800-428-5655 ~ [WWW.LANDOLL.COM](http://WWW.LANDOLL.COM)

---

## Manuals for the 9630FH FC

MANUAL NUMBER	MANUAL NAME
F-1104	9630FH FC Operator's Manual
F-1105	9630FH FC Parts Manual

# Table of Contents

---

## 1 Introduction and Safety Information

Understanding Safety Statements	1-2
Decal Safety	1-2
Transporting Safety	1-2
Attaching, Detaching, and Storage	1-3
Maintenance Safety	1-3
High Pressure Fluid Safety	1-3
Protective Equipment	1-3
Chemical Safety	1-3
Prepare for Emergencies	1-3
Tire Safety	1-4
Safety Chain	1-4

## 2 Standard Specifications

Model Specifications	2-1
General Torque Specifications (rev. 4/97)	2-2
Hydraulic Fitting Torque Specifications	2-3

## 3 Assembly Instructions

Center Frame Assembly- 9630FH	3-2
Center Frame Fold and Depth Control Assembly	3-4
Gauge Wheel Assembly Center	3-6
Hitch Assembly	3-8
Wing Frame Assembly	3-10
Wing Gauge Wheel Installation	3-10
Hydraulic Installation	3-12
LED Light Installation	3-22
Shank Installation	3-26
4 Row Coil Tine Harrow Installation	3-28
3 Row Coil Tine and Reel Harrow Installation	3-30
5 Row Spike Harrow Installation	3-32
3 Row Spike and Reel Harrow Installation	3-34
Rear Tow Hitch (Option)	3-36

## 4 Operation and Maintenance

Hydraulic Lift System	4-2
Hydraulic Fold System	4-4
Transporting	4-6
Tractor Preparation	4-7
Prior to Transport	4-7
Leveling (Side to Side)	4-7
Depth Stop Adjustment	4-10
LED Light Operation	4-10
General Operation	4-10
Spring Shank	4-11
Sweeps	4-11
Wheel Bearing Maintenance – Non Triple-Lip	4-12
Wheel Bearing Maintenance -- Triple-Lip	4-12

---

Lubrication .....	4-13
4 Row Coil Tine Harrow Adjustments .....	4-16
3 Row Coil Tine and Reel Adjustments .....	4-18
5 Row Spike Harrow Adjustments .....	4-20
3 Row Spike and Reel Adjustments .....	4-22
Storage .....	4-24

## **5 Troubleshooting Guide**

## Introduction and Safety Information

---

### Introduction

The Landoll Model 9630FH Field Cultivator is a quality product designed to give years of trouble free performance. By following each section of this manual, your system will perform as designed for you and your operation.

- CHAPTER 1** Gives basic instructions on the use of this manual and understanding the safety statements.
- CHAPTER 2** Gives product specifications for the equipment. These specifications supply lengths and measures for your equipment. A Standard Bolt Torque Table is provided to give guidelines for bolt torques to be used when servicing this product.
- CHAPTER 3** Contains assembly instructions for your 9630 Field Cultivator. When these procedures are correctly followed, your equipment should provide you years of trouble-free operation and service.
- CHAPTER 4** Instructs how to operate your equipment before using it, and describes adjustments needed. Gives practical advice for the care and maintenance of your Landoll equipment. Drawings in this section locate adjustment points on the equipment.

**IF YOU HAVE ANY QUESTIONS CONTACT:**

**LANDOLL COMPANY, LLC  
1900 NORTH STREET  
MARYSVILLE, KANSAS 66508**

**PHONE # (785) 562-5381 or (800) 428-5655  
OR  
FAX # (888) 527-3909**

- CHAPTER 5** Is a troubleshooting guide to aid in diagnosing and solving problems with the equipment.
- PARTS MANUAL** Is a separate manual showing the various assemblies, subassemblies, and systems. Refer to that manual when ordering Landoll replacement parts. Order parts from your Landoll dealer.
- WARRANTY** The Warranty Registration form is included with the product documents. Fill it out and mail it within 15 days of purchase.  
**NOTE: IMPROPER ASSEMBLY, MODIFICATION, OR MAINTENANCE OF YOUR LANDOLL MACHINE CAN VOID YOUR WARRANTY.**
- COMMENTS** Address comments or questions regarding this publication to:

**LANDOLL COMPANY, LLC  
1900 NORTH STREET  
MARYSVILLE, KANSAS 66508  
ATTENTION: PUBLICATIONS - DEPT. 55**

### Understanding Safety Statements

You will find various types of safety information on the following pages and on the machine signs (decals) attached to the vehicle. This section explains their meaning.



The Safety Alert Symbol means ATTENTION! YOUR SAFETY IS INVOLVED!

#### NOTE

*Means that failure to follow these instructions could cause damage to the equipment or cause it to operate improperly.*

#### NOTICE

Special notice - read and thoroughly understand



#### CAUTION

Caution means serious equipment or other property damage can occur if instructions on this label are not properly followed.



#### WARNING

Warning means serious injury or death can occur if safety measures or instructions on this label are not properly followed.



#### DANGER

Danger means a life-threatening situation exists. Death can occur if safety measures or instructions on this label are not properly followed.

#### NOTE

*Make sure you read and understand the information contained in this manual and on the machine signs (decals) before you attempt to operate or maintain this vehicle.*

The safety statements contained in this manual relate to the operation of the Model 9630FH Field Cultivator.

### Decal Safety

1. Examine safety decals and be sure you have the correct safety decals for the implement.
2. Keep these signs clean so they can be observed readily. It is important to keep these decals cleaned more frequently than the implement. Wash with soap and water or a cleaning solution as required.
3. Replace decals that become damaged or lost. Also, be sure that any new implement components installed during repair include decals which are assigned to them by the manufacturer.
4. When applying decals to the implement, be sure to clean the surface to remove any dirt or residue. Where possible, sign placement should protect the sign from abrasion, damage, or obstruction from mud, dirt, oil etc.



#### DANGER

- Do not allow anyone to ride on the tractor or implement. Riders could be struck by foreign objects or thrown from the implement.
- Never allow children to operate equipment.
- Keep bystanders away from implement during operation.

### Transporting Safety

1. Thoroughly read and understand all operating procedures contained in this manual before attempting to transport this implement.
2. **It is the responsibility of the operator to understand and comply with all federal, state, and local requirements before transporting the field cultivator.**
3. When transporting the implement on road or highway, use adequate warning symbols, reflectors, lights, SIS, and slow moving vehicle signs as required. Verify that all symbols and lights are clearly visible and functioning before transporting. Transport during daylight hours whenever possible. Slow moving tractors and implements can create a hazard when driven on public roads and can be difficult to see especially at night.
4. Do not tow an implement that when fully loaded, that weighs more than 1.5 times the weight of the towing vehicle. Never tow the implement with a motor vehicle. Tow the implement only with a properly ballasted tractor.
5. Use a locking-style hitch pin that properly fits the tractor drawbar and the implement hitch. Lock the tractor drawbar in the center position to prevent loss of steering control.

6. Attach the safety chain to the tractor recommended drawbar support. Provide only enough slack in the chain for turning. Do not attach the safety chain to an intermediate support. Safety chain must have rating greater than the gross weight of the towed implement(s). Replace the safety chain if it is worn or damaged in any way.
7. Verify that all hydraulic hoses and electrical wiring between the tractor and implement are safely routed to avoid damage.
8. Check implement tire pressure for correct inflation. Verify that lug nuts are properly torqued before transporting.
9. Install all transport locks and pins before transporting.
10. Never allow riders on the implement.
11. **Maximum transport speed for the field cultivator is 20 mph, regardless of the tractor capabilities.** Excessive speed may result in loss of control of the tractor and implement, reduced braking, or failure of the implement tires and/or structure. Slow down when road surface conditions are poor or rough, or when driving on inclines. Reduce speed when turning, on curves and slopes, to avoid tipping. Equipment altered other than the place of manufacture, may further reduce the maximum transport speed.
12. Avoid overhead power lines. Serious injury or death can result. Electrocution can occur without direct contact. Know the transport height and width of the implement before transporting. Attachments can increase the height and width of the implement.

## Attaching, Detaching, and Storage

1. Do not stand between the tractor and implement when attaching or detaching implement unless both are not moving.
2. Block implement so it will not roll when unhitched from the tractor.
3. Store in an area where children normally do not play.

## Maintenance Safety

1. Understand the procedure before doing the work. Use proper tools and equipment.
2. Make sure all moving parts have stopped.
3. Do not make adjustments or lubricate implement while it is in motion.
4. Block the implement so it will not roll when working on or under it to prevent injury.
5. Install hydraulic cylinder lockouts, or lower equipment to the ground before servicing.

## High Pressure Fluid Safety

1. Escaping fluid under pressure can be nearly invisible and have enough force to penetrate the skin causing serious injury. Use a piece of cardboard, rather than hands, to search for suspected leaks.
2. Any fluid injected into the skin must be surgically removed within a few hours or gangrene may result.
3. Avoid the hazard by relieving pressure before disconnecting hydraulic lines.

## Protective Equipment

1. Wear protective clothing and equipment.
2. Wear clothing and equipment appropriate for the job. Avoid loose fitting clothing.



3. Because prolonged exposure to loud noise can cause hearing impairment or hearing loss, wear suitable hearing protection, such as earmuffs or earplugs.

## Chemical Safety

1. Agricultural chemicals can be dangerous. Improper use can seriously injure persons, animals, plants, soil and property.
2. Read chemical manufacture's instructions and store or dispose of unused chemicals as specified.
3. Handle chemicals with care and avoid inhaling smoke from any type of chemical fire.
4. Store or dispose of unused chemicals as specified by the chemical manufacturer.

## Prepare for Emergencies

1. Keep a First Aid Kit and Fire Extinguisher handy.
2. Keep emergency numbers for doctor, ambulance, hospital and fire department near the phone.

### Tire Safety

1. Tire changing can be dangerous and should be performed by trained personnel using correct tools and equipment.
2. When inflating tires, use a clip-on chuck and extension hose long enough to allow you to stand to one side, not in front of or over the tire assembly. Use a safety cage if available.
3. When removing and installing wheels use wheel-handling equipment adequate for the weight involved.

### Safety Chain

1. Use a chain with a strength rating equal to or greater than the gross weight of towed machinery, which is 10,100 pounds minimum in accordance with ASAE S338.2 specifications. If two or more implements are pulled in tandem, a larger chain may be required. Chain capacity must be greater than the TOTAL weight of all towed implements.
2. Additional safety chain should be used between each implement.
3. Attach the chain to the tractor drawbar support or specified anchor location. Allow only enough slack in the chain to permit turning. The distance from hitch pin to attachment point or intermediate support point should not exceed 9 inches.
4. Replace the chain if any links or end fittings are broken, stretched or damaged.
5. Do not use a safety chain for towing.



## Standard Specifications

### Model Specifications

9630FH Field Cultivator			
Model Number	9630FH-30	9630FH-32	9630FH-34
Working Width	30'-6"	32'-6"	34'-6"
Transport Width	17'-2"	17'-2"	17'-2"
Transport Height	13'-5"	14'-0"	14'-11"
Number of Shanks	61	93	101
Shanks per Section	17-27-17	19-27-19	21-27-21
Spindle Size	3" Center Frame, 2-1/4" Wings	3" Center Frame, 2-1/4" Wings	3" Center Frame, 2-1/4" Wings
Wheel Bolt Pattern	8 Bolt Wheels Center 6 Bolt Wings & Gauge Wheels	8 Bolt Wheels Center 6 Bolt Wings & Gauge Wheels	8 Bolt Wheels Center 6 Bolt Wings & Gauge Wheels
Estimated Weight			
<b>NOTE: Specifications Are Subject To Change Without Prior Notification</b>			

Tire Inflation			
Tire Size	Tire Manufacturer	Ply/Load Rating	Inflation Pressure (Psi) (Max.)
320/70R15	Firestone	Load Index 144 - 6150 lbs. @ 40 mph	70 psi.
280/70R15	Firestone	Load Index 134 - 4680 lbs. @ 40 mph	64 psi

Specific Bolt Torques	
Lug Bolts & Nuts	Torque (FT. LBS.)
Center Frame 5/8-18 Wheel Nuts	85-100 Ft./Lbs.
Wing Frame 9/16-18 Wheel Nuts	80-90 Ft./Lbs.

# General Torque Specifications (rev. 4/97)

**TORQUE SPECIFIED IN FOOT POUNDS** - This chart provides tightening torques for general purpose applications when special torques are not specified on process or drawing. Assembly torques apply to plated nuts and capscrews assembled without supplemental lubrication (as received condition). They do not apply if special graphite moly-disulfide or other extreme pressure lubricants are used. When fasteners are dry (solvent cleaned) add 33% to as received condition torque. Bolt head identification marks indicate grade and may vary from manufacturer to manufacturer. Thick nuts must be used on grade 8 capscrews. Use value in [ ] if using prevailing torque nuts.

UNC SIZE	SAE Grade 2	SAE Grade 5	SAE Grade 8	UNF SIZE	SAE Grade 2	SAE Grade 5	SAE Grade 8
1/4-20	4 [5]	6 [7]	9 [11]	1/4-28	5 [6]	7 [9]	10 [12]
5/16-18	8 [10]	13 [13]	18 [22]	5/16-24	9 [11]	14 [17]	20 [25]
3/8-16	15 [19]	23 [29]	35 [42]	3/8-24	17 [21]	25 [31]	35 [44]
7/16-14	24 [30]	35 [43]	55 [62]	7/16-20	27 [34]	40 [50]	60 [75]
1/2-13	35 [43]	55 [62]	80 [100]	1/2-20	40 [50]	65 [81]	90 [112]
9/16-12	55 [62]	80 [100]	110 [137]	9/16-18	60 [75]	90 [112]	130 [162]
5/8-11	75 [94]	110 [137]	170 [212]	5/8-18	85 [106]	130 [162]	180 [225]
3/4-10	130 [162]	200 [250]	280 [350]	3/4-16	150 [188]	220 [275]	320 [400]
7/8-9	125 [156]	320 [400]	460 [575]	7/8-14	140 [175]	360 [450]	500 [625]
1-8	190 [237]	408 [506]	680 [850]	1-14	210 [263]	540 [675]	760 [950]
1-1/8-7	270 [337]	600 [750]	960 [1200]	1-1/8-12	300 [375]	660 [825]	1080 [1350]
1-1/4-7	380 [475]	840 [1050]	1426 [1782]	1-1/4-12	420 [525]	920 [1150]	1500 [1875]
1-3/8-6	490 [612]	1010 [1375]	1780 [2225]	1-3/8-12	560 [700]	1260 [1575]	2010 [2512]
1-1/2-6	650 [812]	1460 [1825]	2360 [2950]	1-1/2-12	730 [912]	1640 [2050]	2660 [3325]
1-3/4-5	736 [920]	1651 [2063]	2678 [3347]	1-3/4-12	920 [1150]	2063 [2579]	3347 [4183]

**METRIC:**

Coarse thread metric class 10.9 fasteners and class 10.0 nuts and through hardened flat washers, phosphate coated, Rockwell "C" 38-45. Use value in [ ] if using prevailing torque nuts.

Nominal thread diameter (mm)	Newton Meters (Standard Torque)	Foot Pounds (Standard Torque)	Nominal Thread Diameter (mm)	Newton Meters (Standard Torque)	Foot Pounds (Standard Torque)
6	10 [14]	7 [10]	20	385 [450]	290 [335]
7	16 [22]	12 [16]	24	670 [775]	500 [625]
8	23 [32]	17 [24]	27	980 [1105]	730 [825]
10	46 [60]	34 [47]	30	1330 [1470]	990 [1090]
12	80 [125]	60 [75]	33	1790 [1950]	1340 [1450]
14	125 [155]	90 [115]	36	2325 [2515]	1730 [1870]
16	200 [240]	150 [180]	39	3010 [3210]	2240 [2380]
18	275 [330]	205 [245]			

Table 2-1: General Torque Specifications

## Hydraulic Fitting Torque Specifications

### TORQUE IS SPECIFIED IN FOOT POUNDS- 37° JIC, ORS, & ORB (REV. 10/97)

This chart provides tightening torques for general purpose applications when special torques are not specified on process or drawing. Assembly torques apply to plated nuts and capscrews assembled without supplemental lubrication (as received condition). They do not apply if special graphite moly-disulfide or other extreme pressure lubricants are used. When fasteners are dry (solvent cleaned) add 33% to as received condition torque. Bolt head identification marks indicate grade and may vary from manufacturer to manufacturer. Thick nuts must be used on grade 8 capscrews. Use value in [ ] if using prevailing torque nuts.

<b>Parker Brand Fittings</b>			
<b>Dash Size</b>	<b>37 Degree JIC</b>	<b>O-Ring (ORS)</b>	<b>O-Ring Boss (ORB)</b>
-4	11-13	15-17	13-15
-5	14-16	-----	21-23
-6	20-22	34-36	25-29
-8	43-47	58-62	40-44
-10	55-65	100-110	58-62
-12	80-90	134-146	75-85
-16	115-125	202-218	109-121
-20	160-180	248-272	213-237
-24	185-215	303-327	238-262
-32	250-290	-----	310-340
<b>Gates Brand Fittings</b>			
<b>Dash Size</b>	<b>37 Degree JIC</b>	<b>O-Ring (ORS)</b>	<b>O-Ring Boss (ORB)</b>
-4	10-11	10-12	14-16
-5	13-15	-----	-----
-6	17-19	18-20	24-26
-8	34-38	32-40	37-44
-10	50-56	46-56	50-60
-12	70-78	65-80	75-83
-14	-----	65-80	-----
-16	94-104	92-105	111-125
-20	124-138	125-140	133-152
-24	156-173	150-180	156-184
-32	219-243	-----	-----
<b>Aeroquip Brand Fittings</b>			
<b>Dash Size</b>	<b>37 Degree JIC</b>	<b>O-Ring (ORS)</b>	<b>O-Ring Boss (ORB)</b>
-4	11-12	10-12	14-16
-5	15-16	-----	16-20
-6	18-20	18-20	24-26
-8	38-42	32-35	50-60
-10	57-62	46-50	75-80
-12	79-87	65-70	125-135
-14	-----	-----	160-180
-16	108-113	92-100	200-220
-20	127-133	125-140	210-280
-24	158-167	150-165	270-360
-32	245-258	-----	-----

Table 2-2: Hydraulic Fitting Torque Specifications



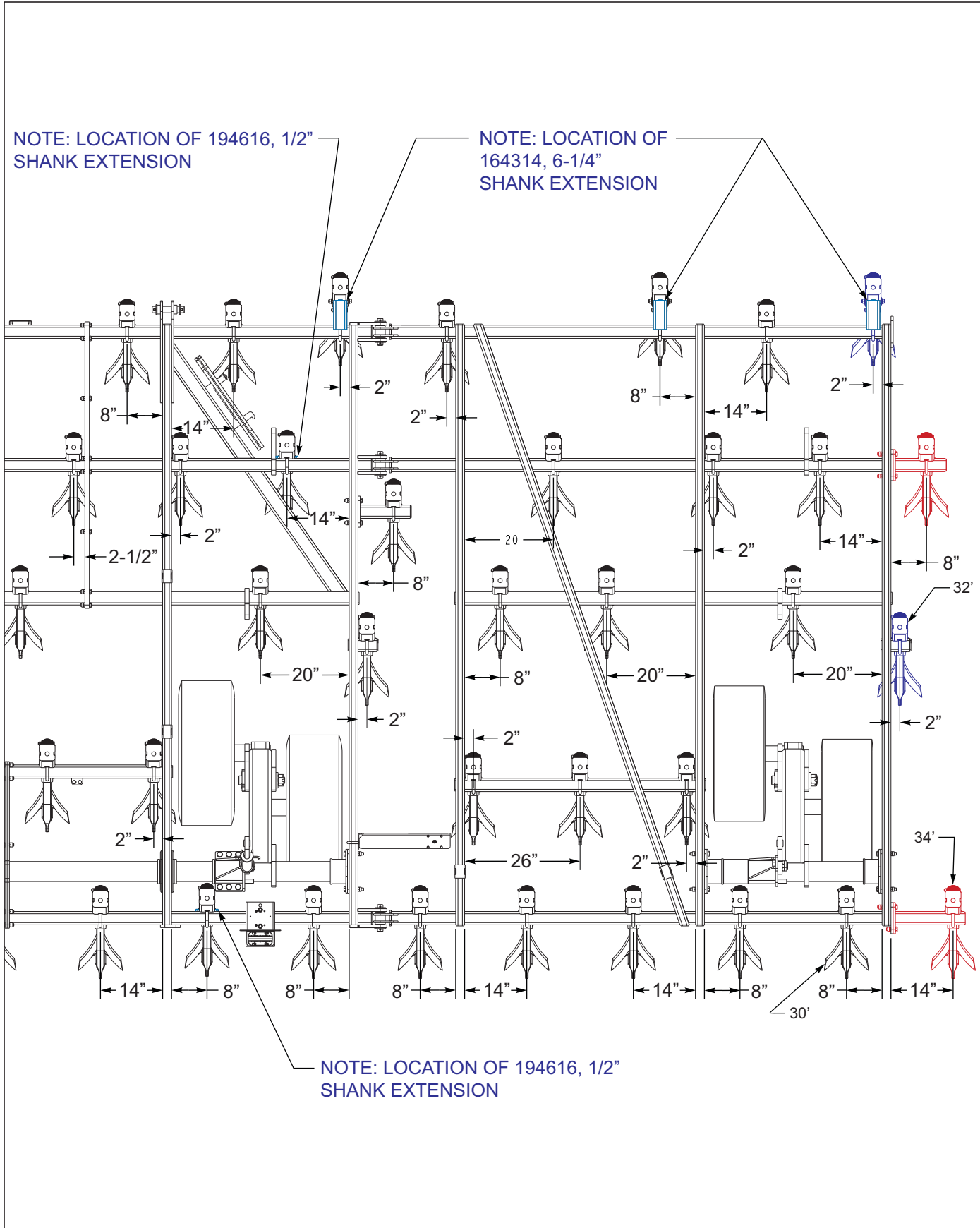

Figure 2-2: Shank Placement 9630FH RH

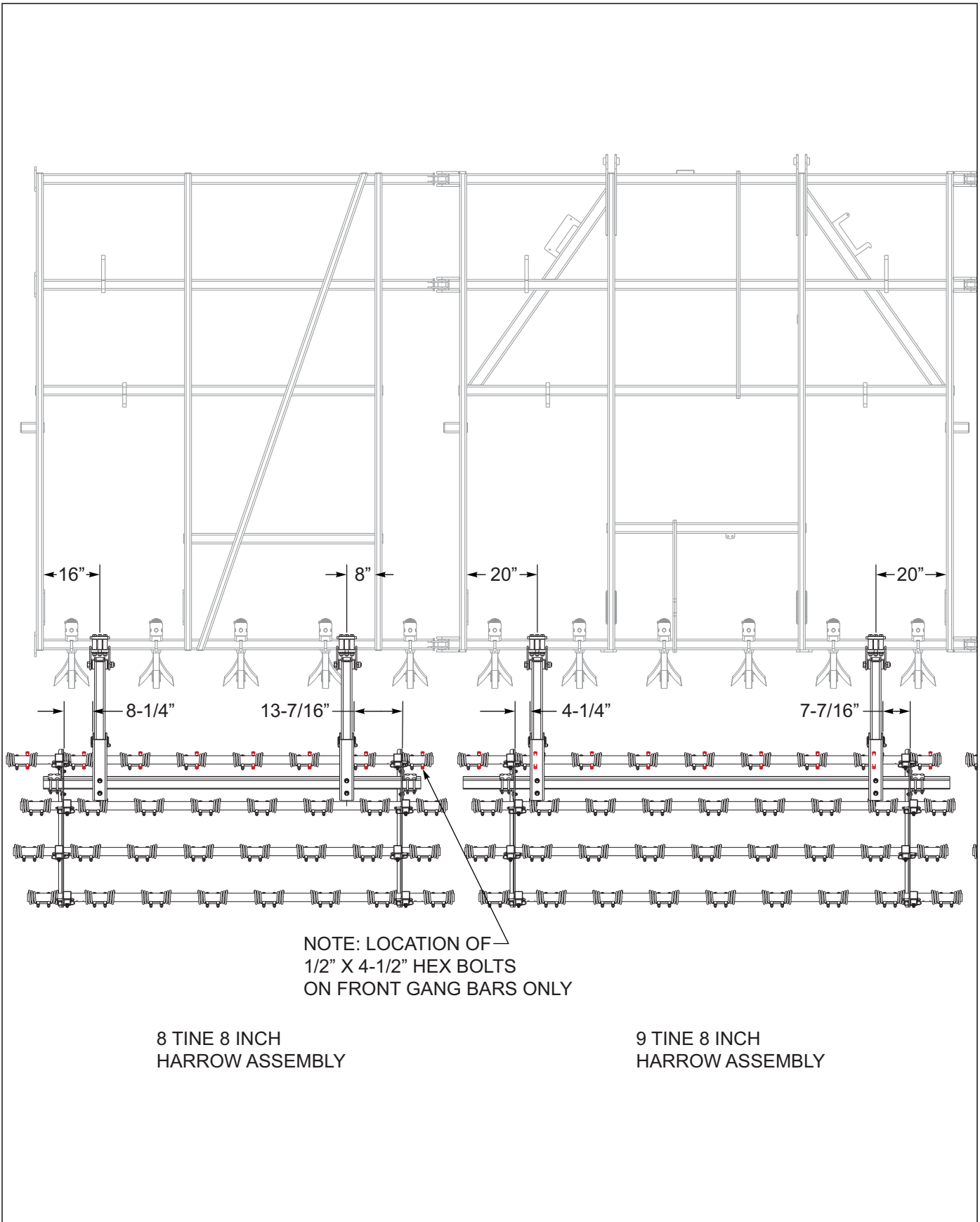

Figure 2-3: 4 Row CT Harrow Placement 9650FH-30' LH

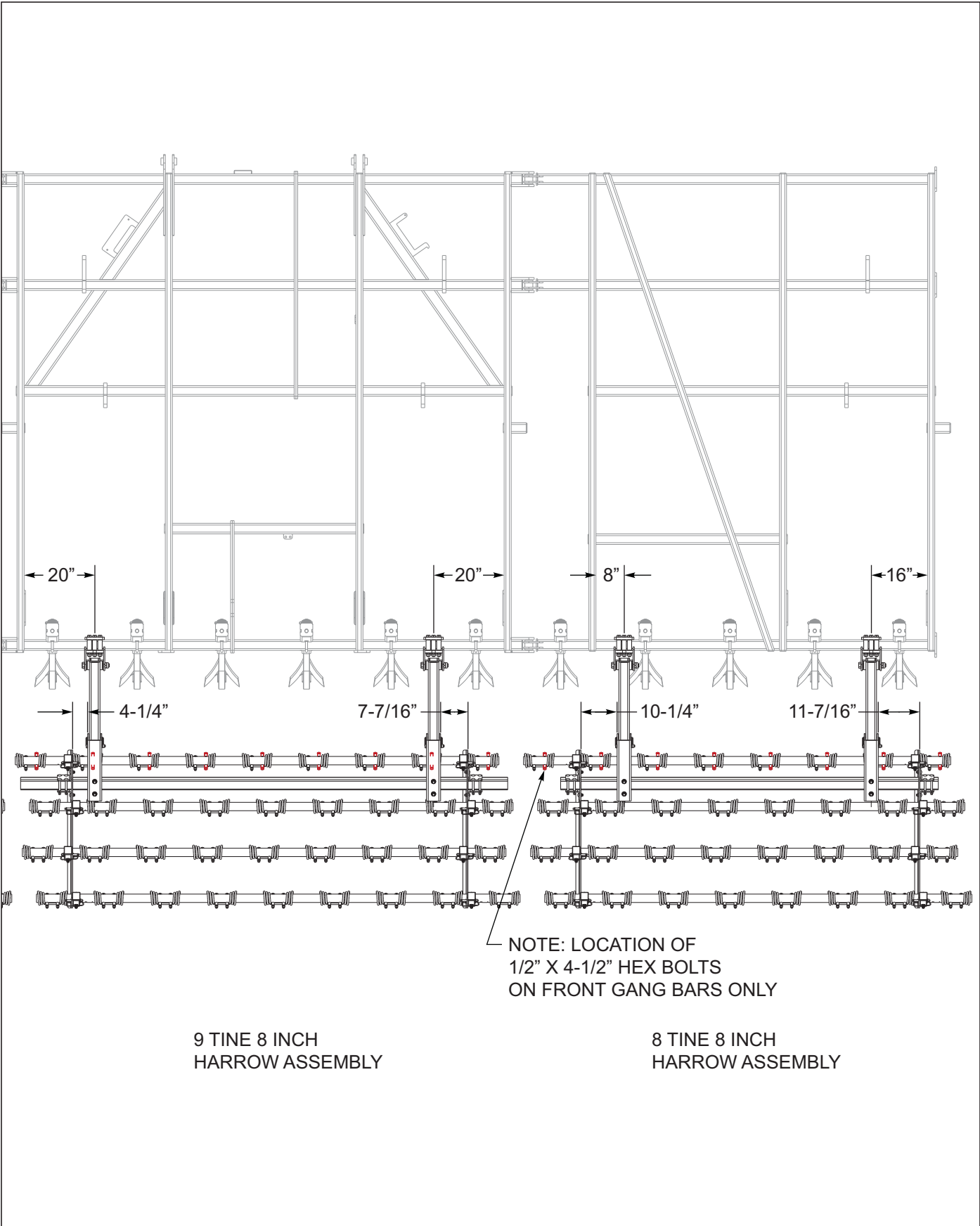

Figure 2-4: 4 Row CT Harrow Placement 9630FH-30' RH

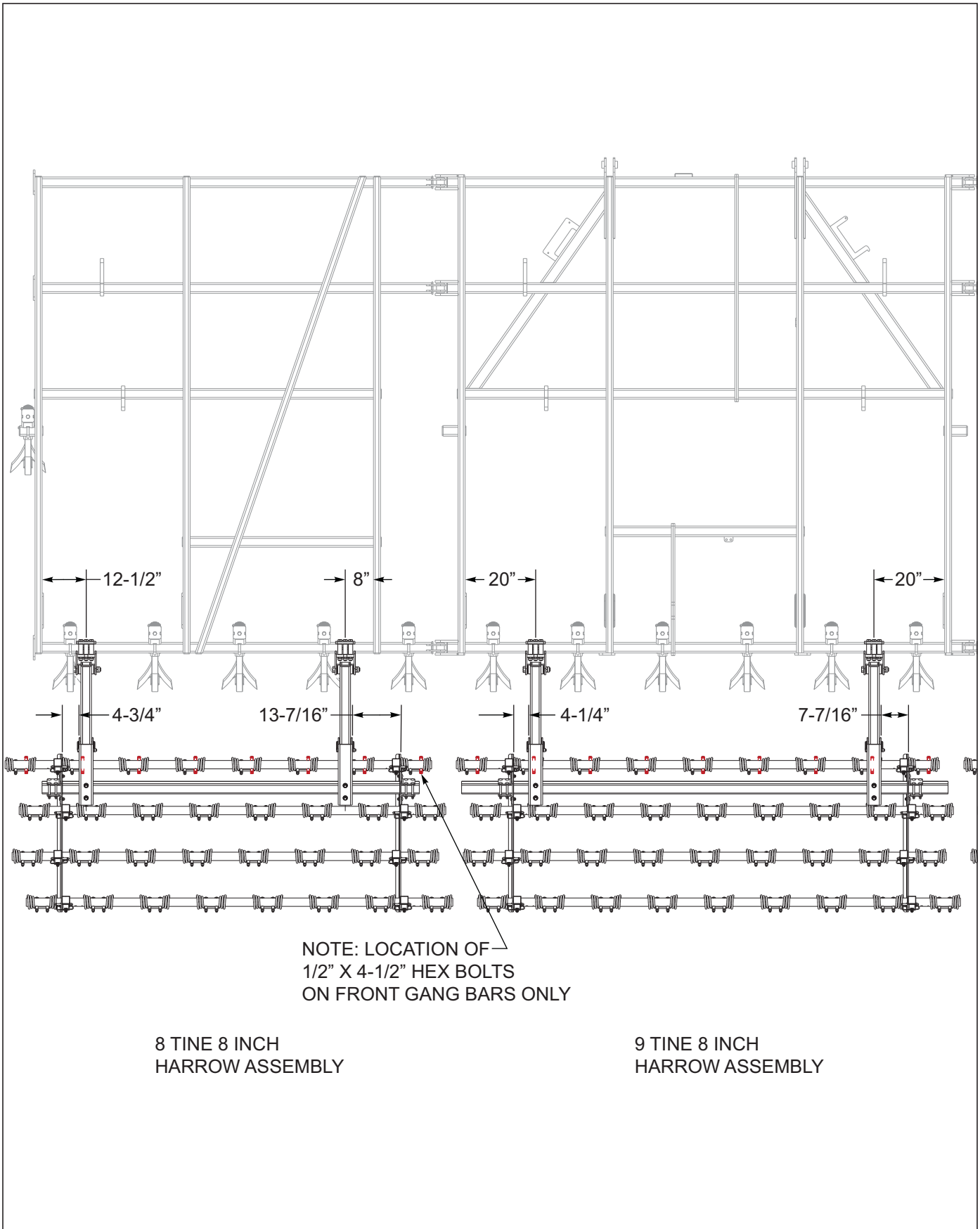

Figure 2-5: 4 Row CT Harrow Placement 9630FH-32' LH



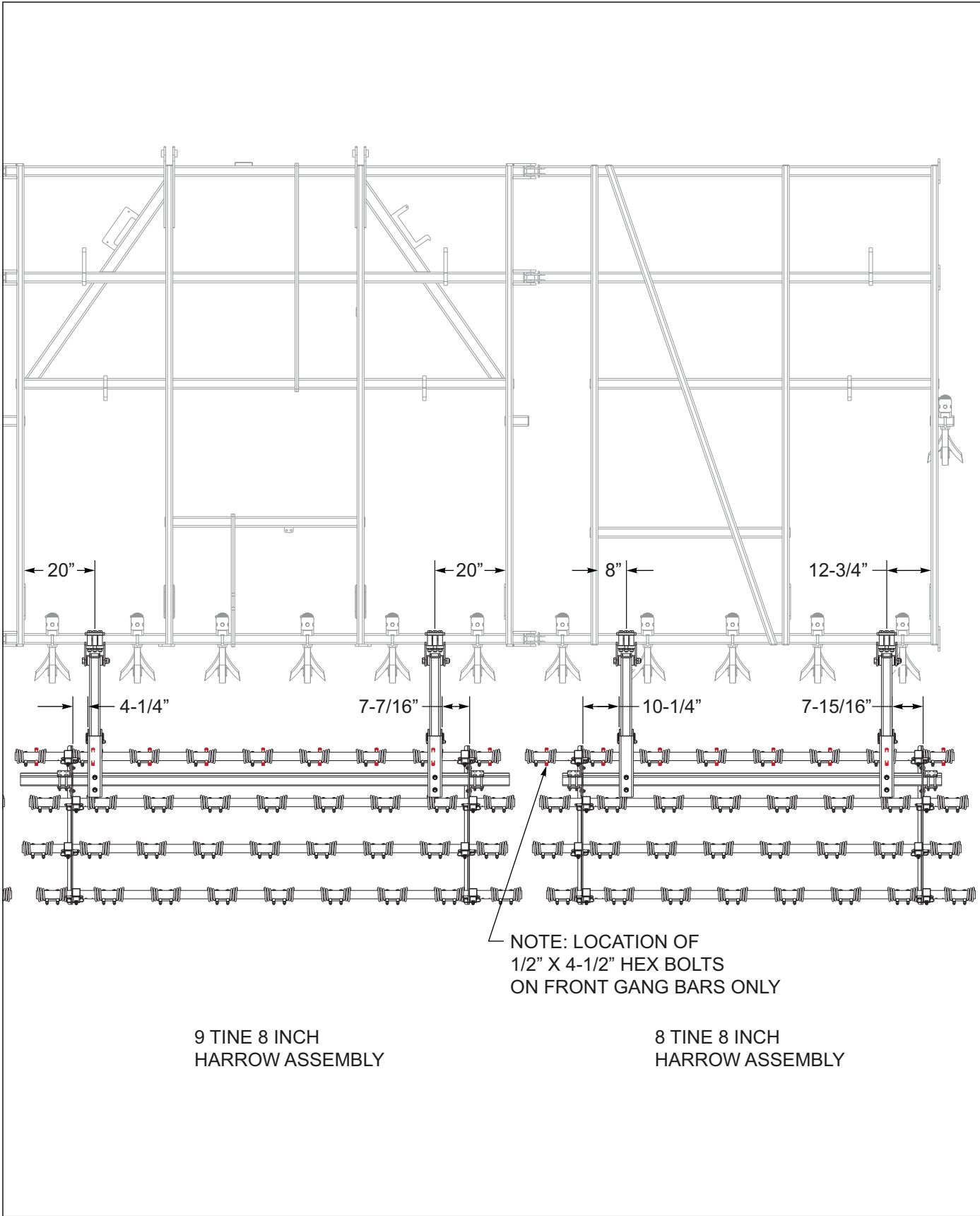

Figure 2-6: 4 Row CT Harrow Placement 9630FH-32' RH

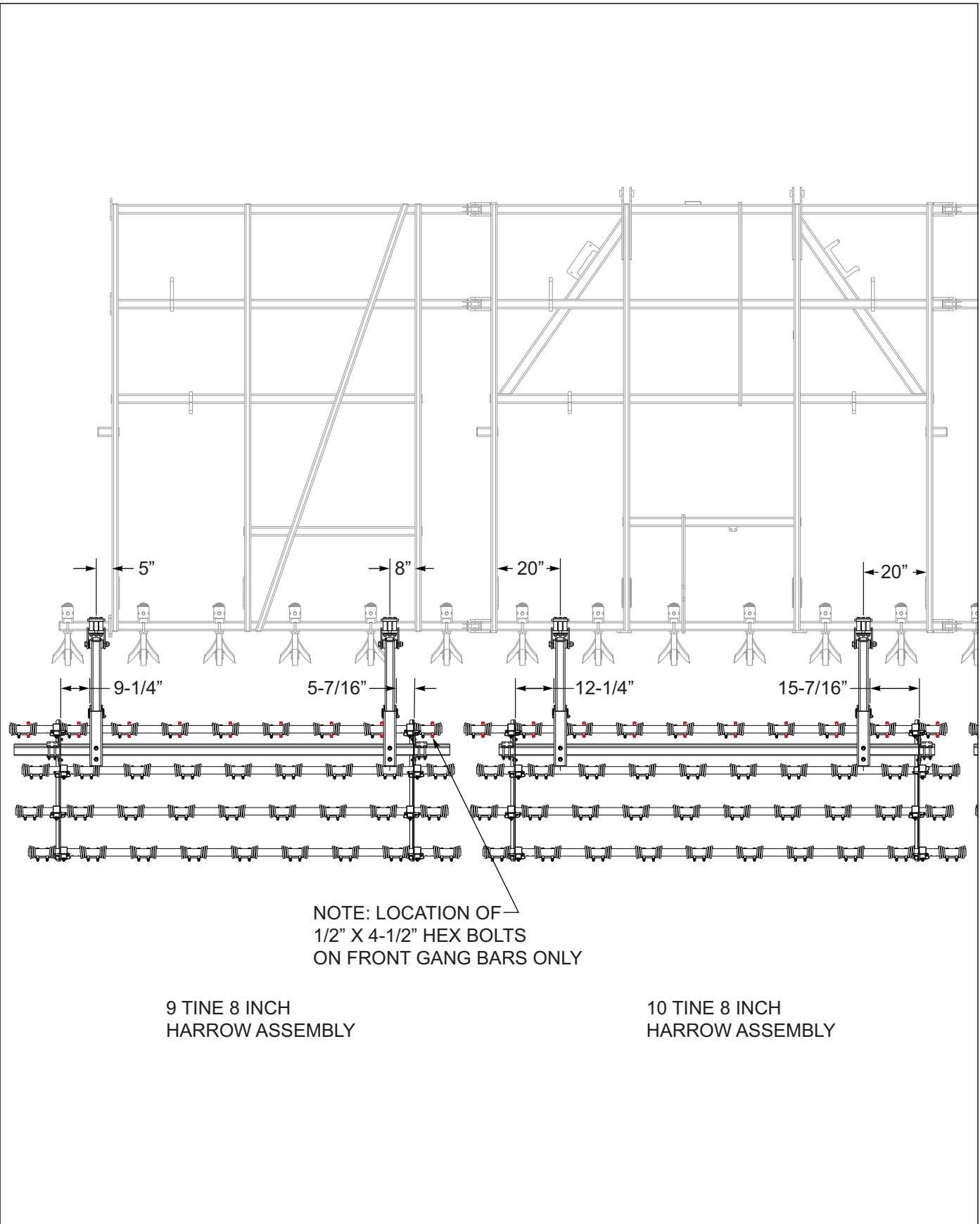

Figure 2-7: 4 Row CT Harrow Placement 9630FH-34' LH

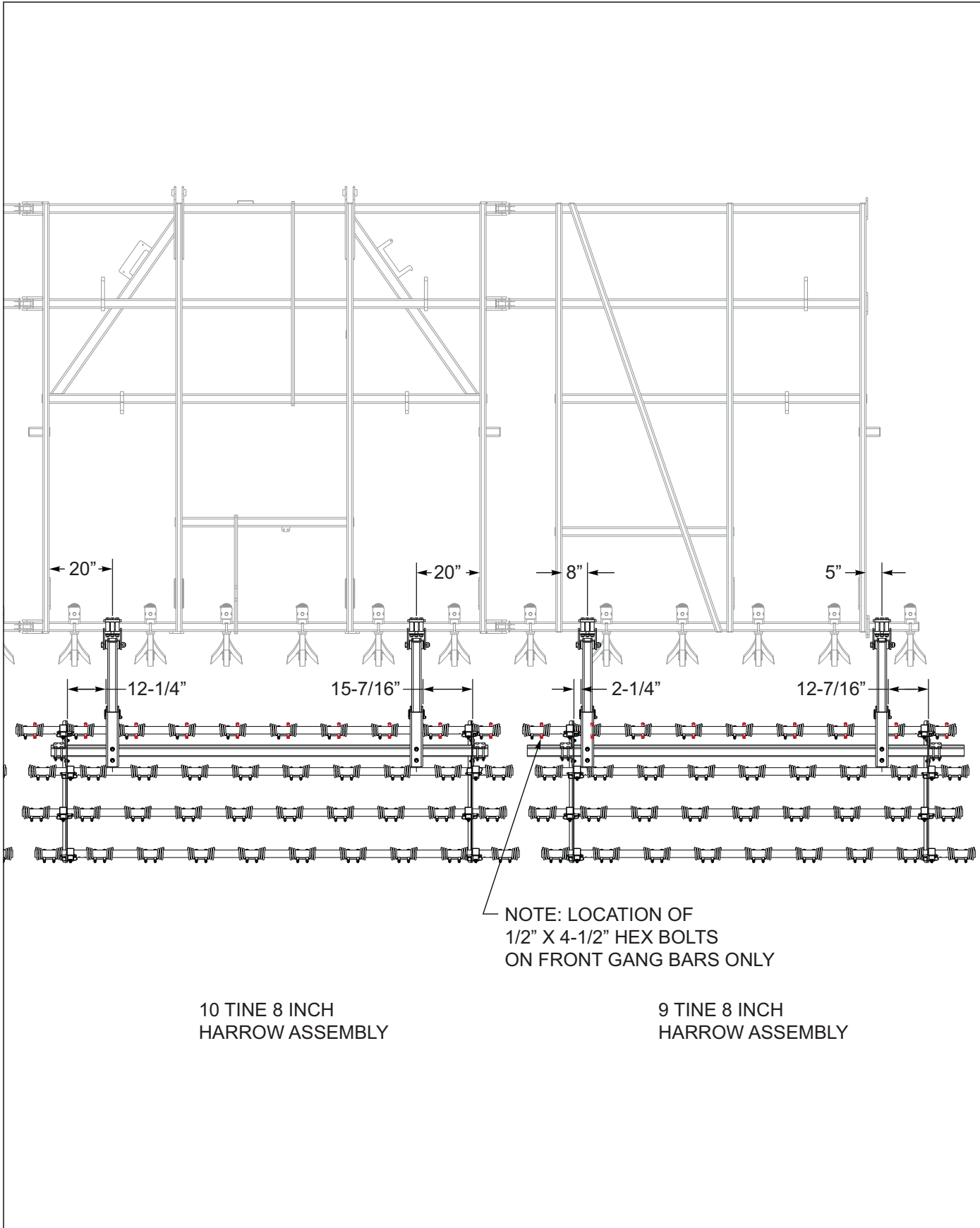

Figure 2-8: 4 Row CT Harrow Placement 9630FH-34' RH

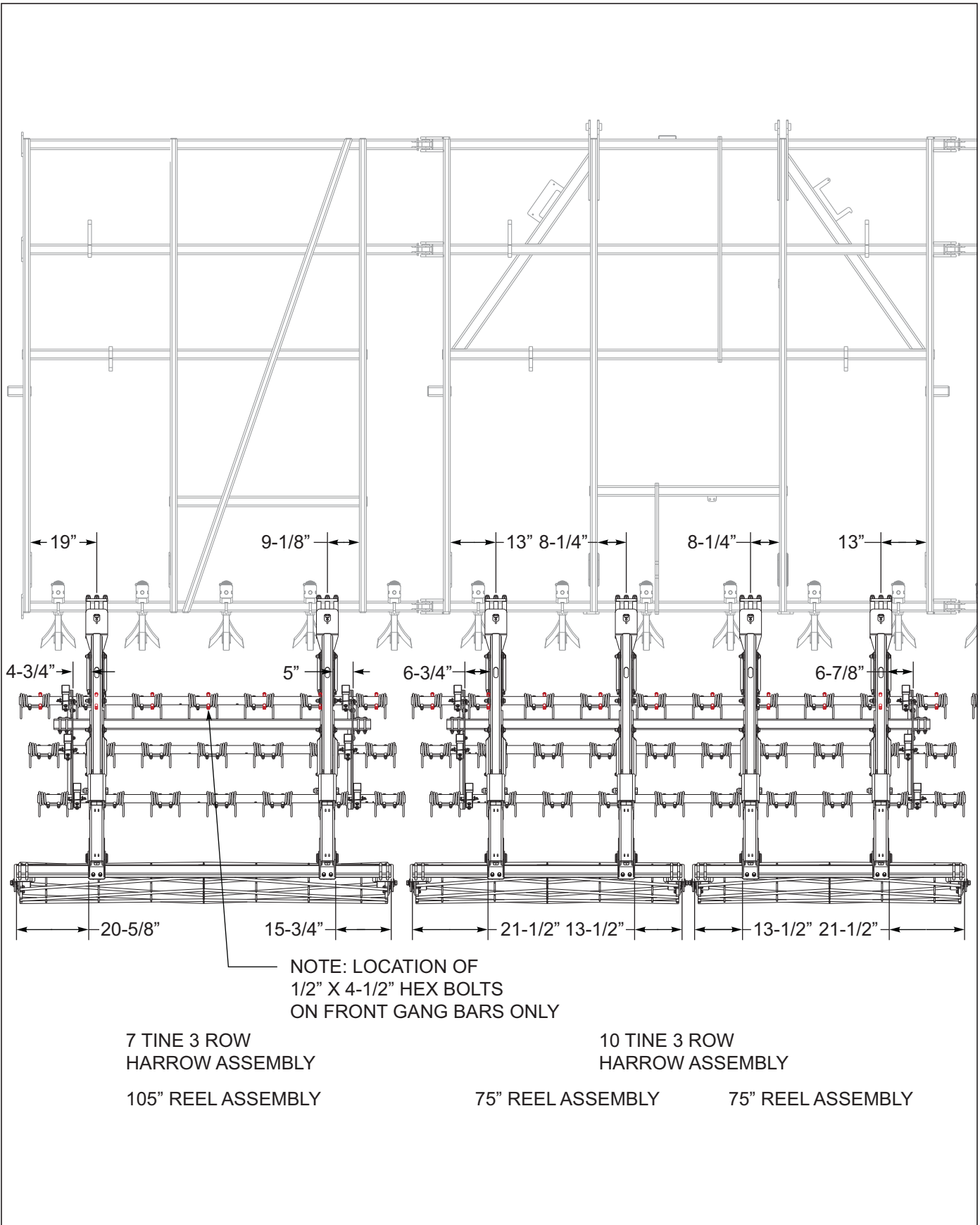

Figure 2-9: 3 Row Tine & Reel Placement 9630FH-30' LH

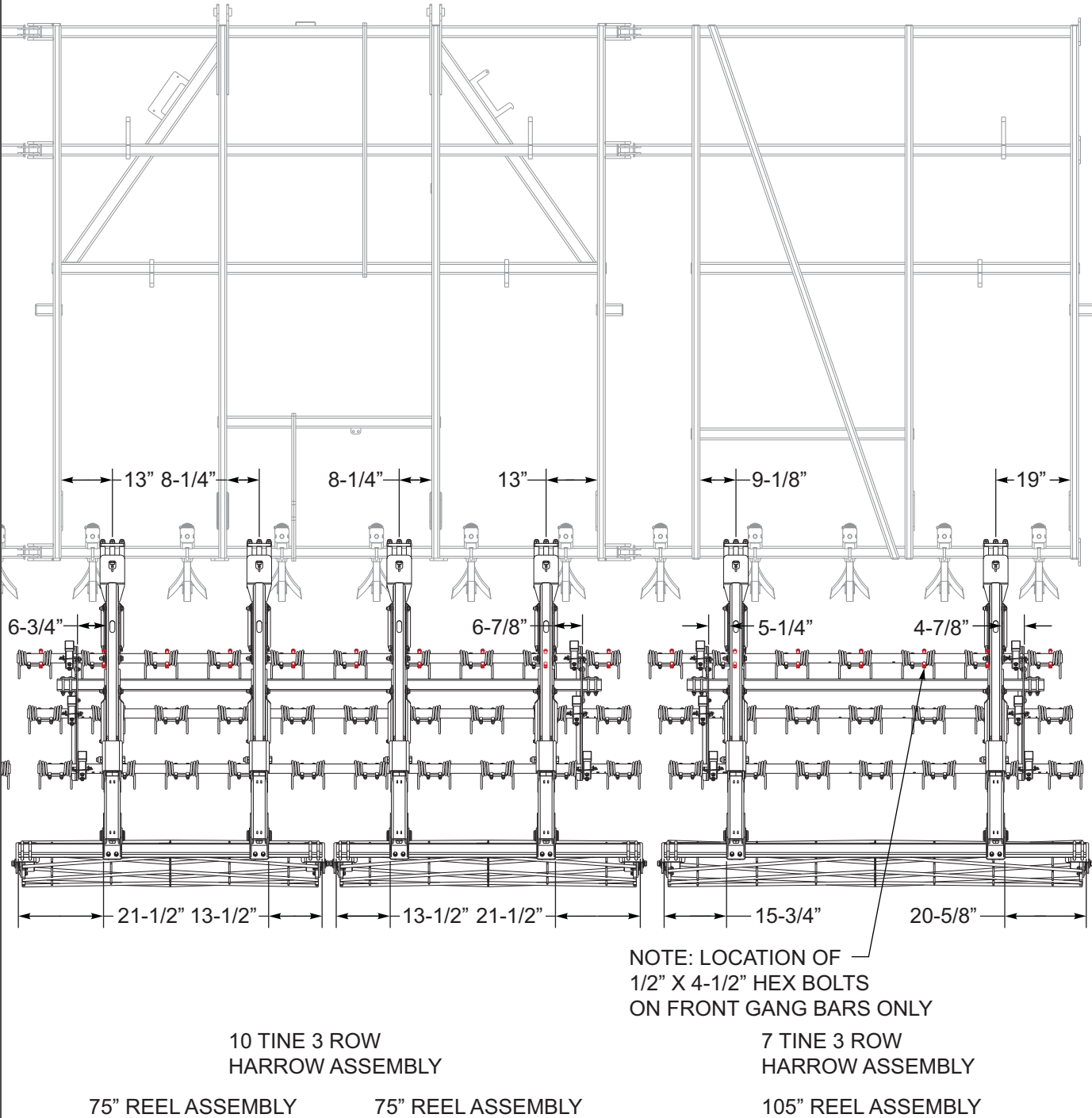

Figure 2-10: 3 Row Tine & Reel Placement 9630FH-30' RH

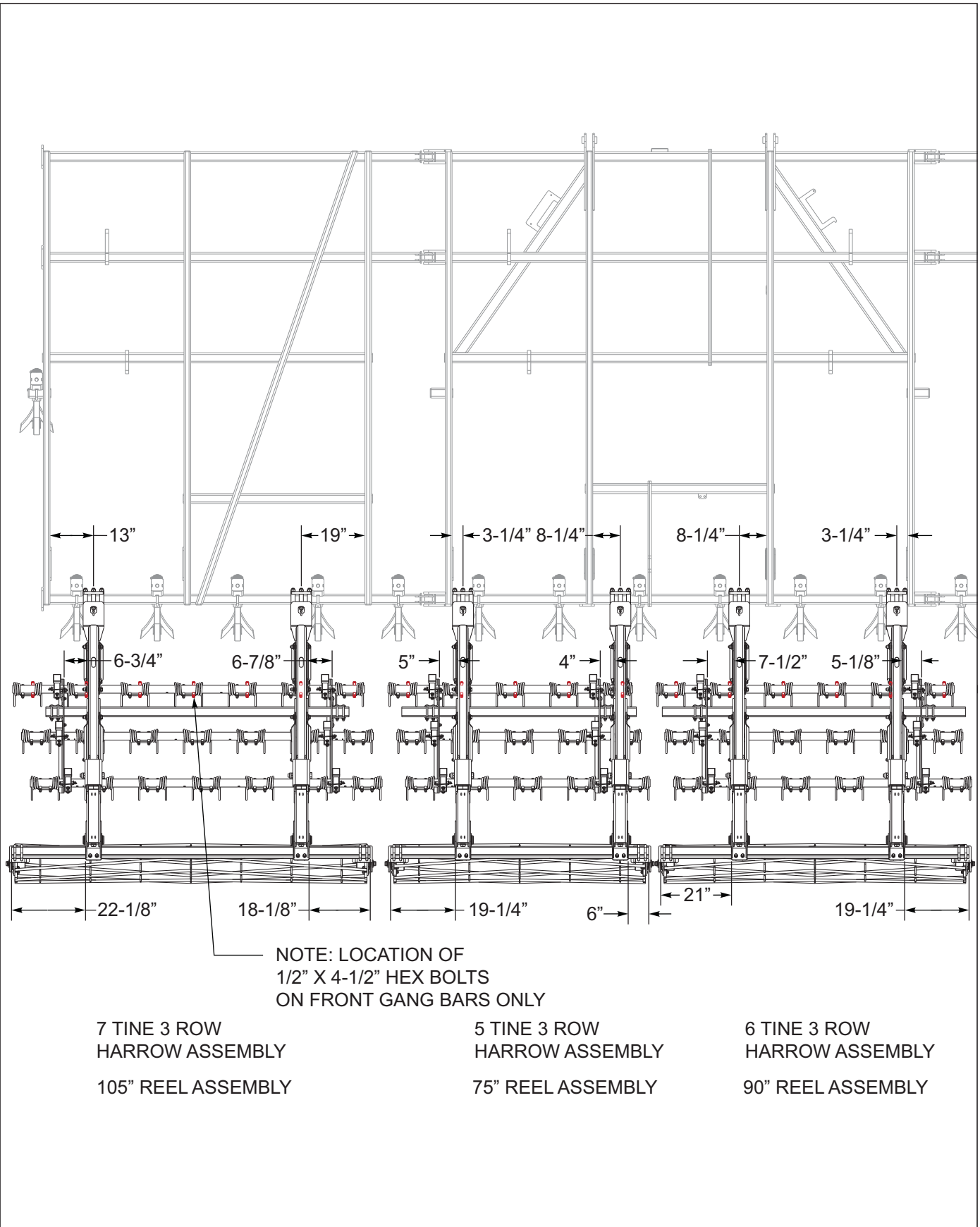

Figure 2-11: 3 Row Tine & Reel Placement 9630FH-32' LH

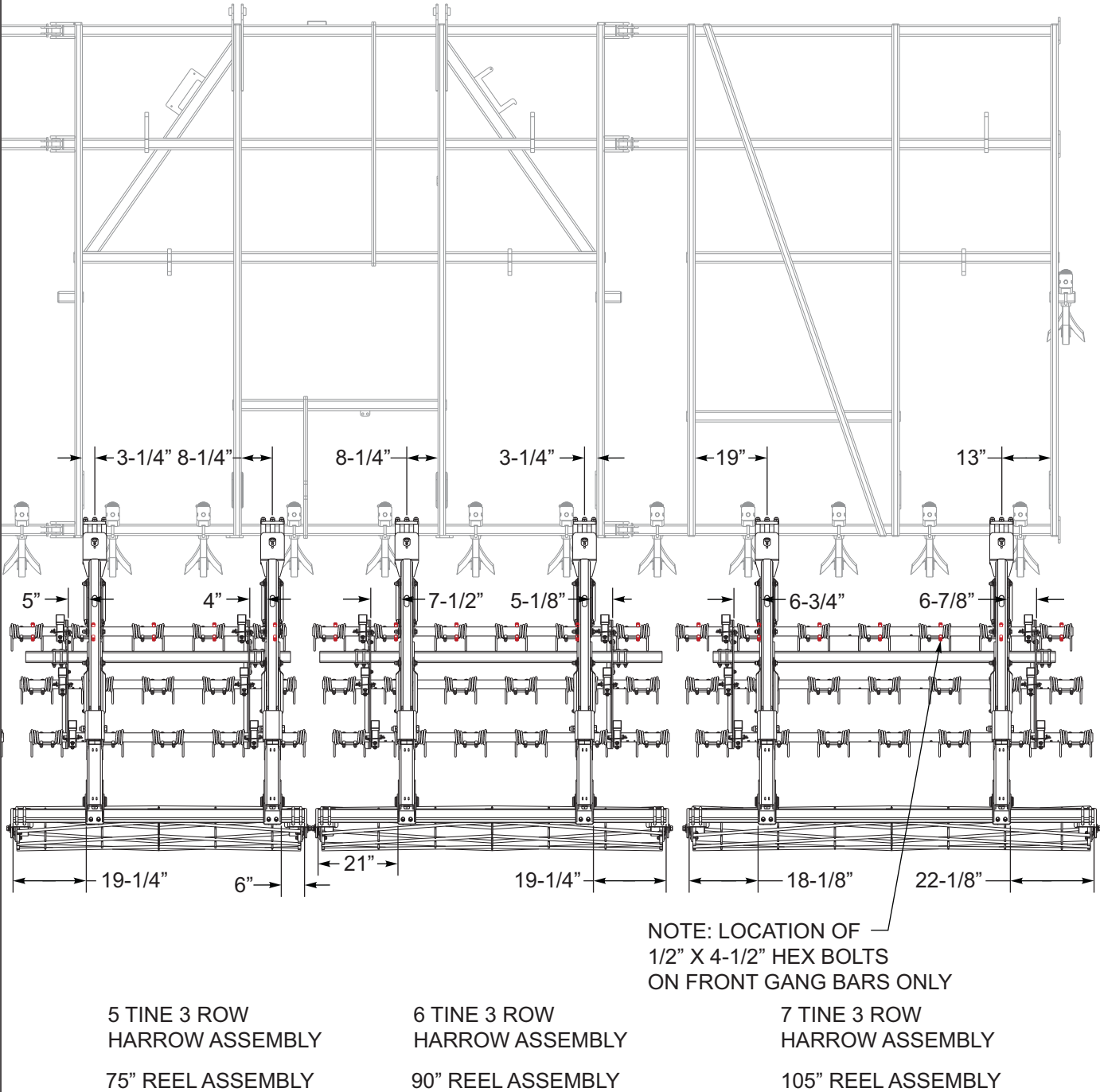

Figure 2-12: 3 Row Tine & Reel Placement 9630FH-32' RH

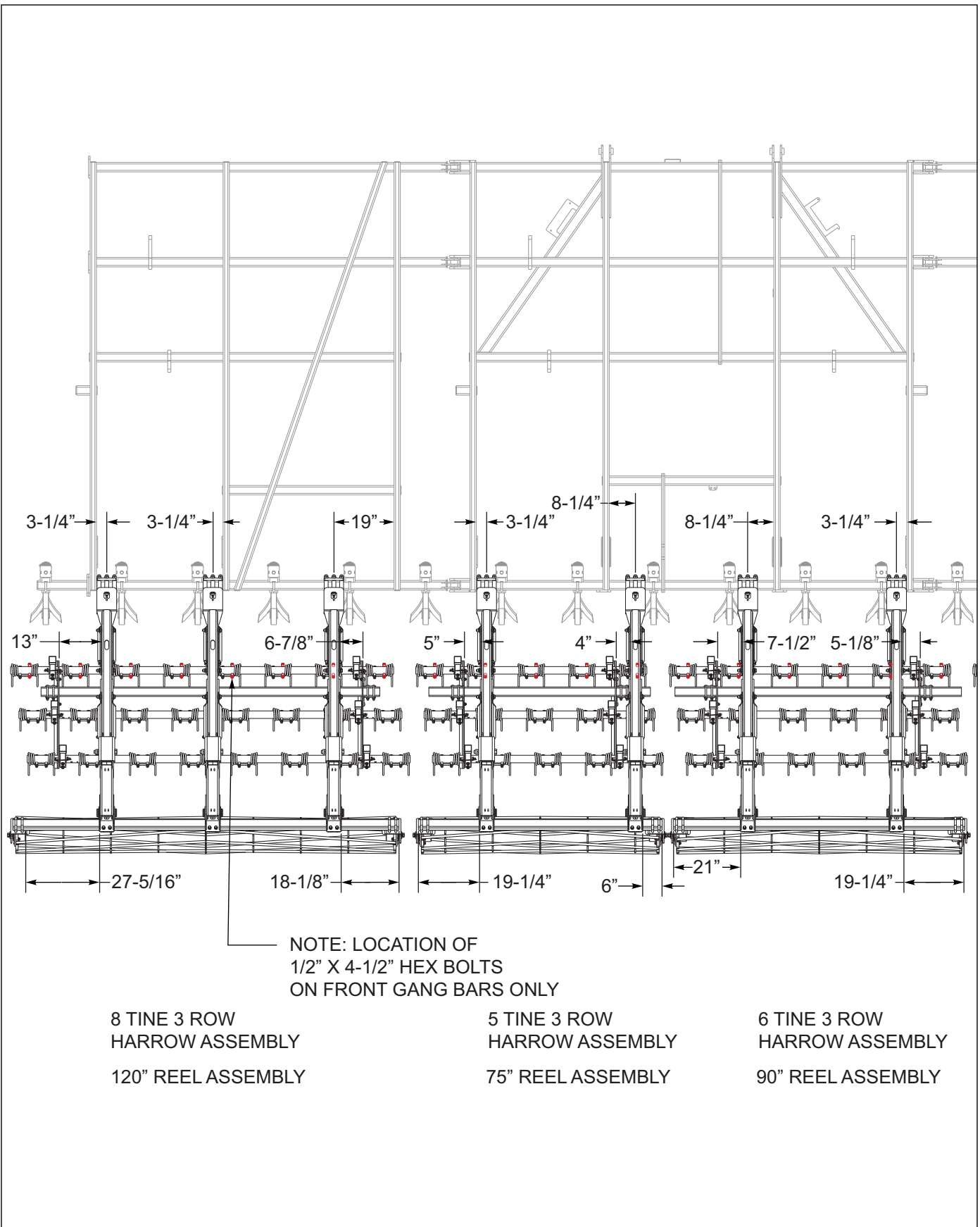
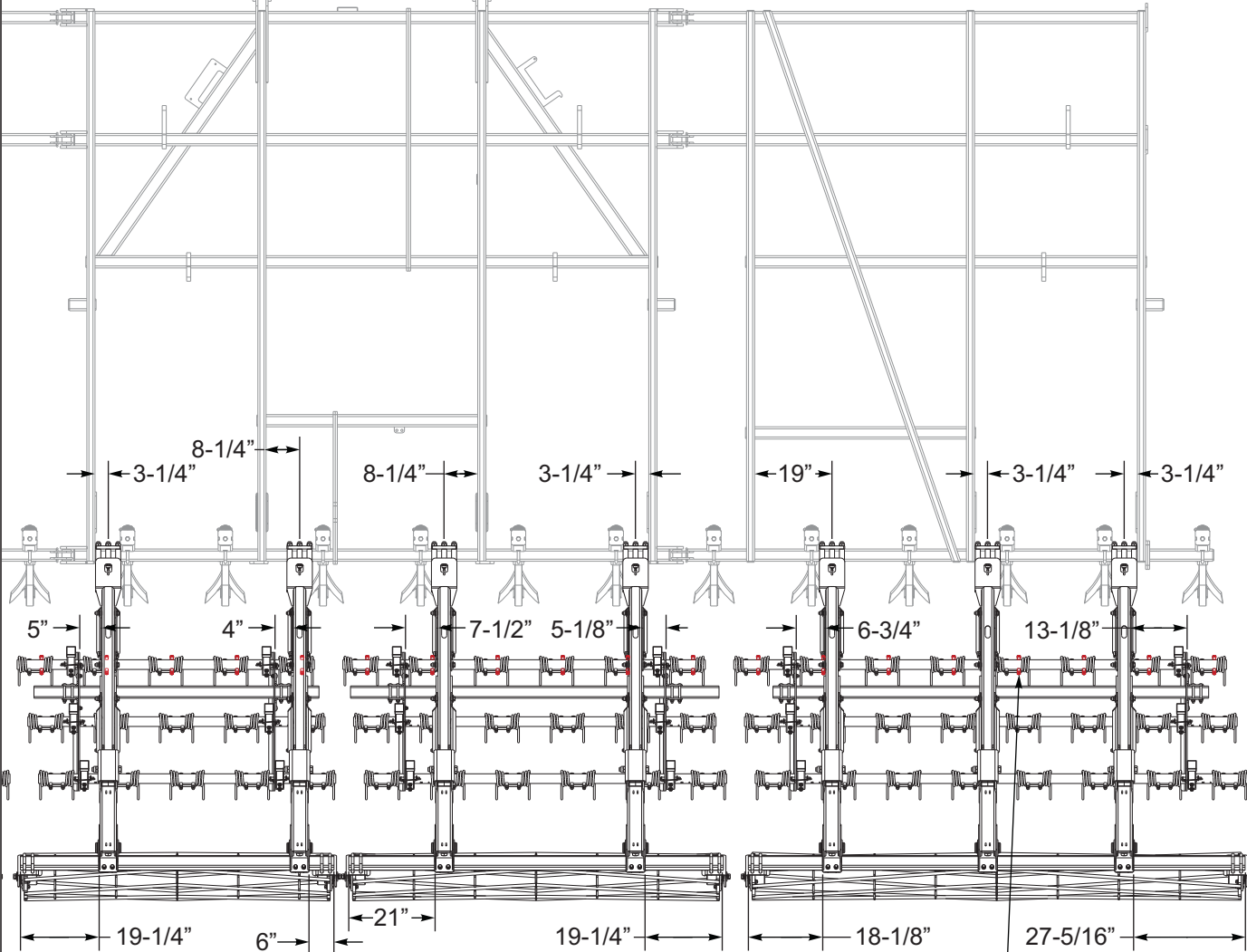

Figure 2-13: 3 Row Tine & Reel Placement 9630FH-34' LH





NOTE: LOCATION OF 1/2" X 4-1/2" HEX BOLTS ON FRONT GANG BARS ONLY

5 TINE 3 ROW  
HARROW ASSEMBLY  
75" REEL ASSEMBLY

6 TINE 3 ROW  
HARROW ASSEMBLY  
90" REEL ASSEMBLY

8 TINE 3 ROW  
HARROW ASSEMBLY  
120" REEL ASSEMBLY

Figure 2-14: 3 Row Tine & Reel Placement 9630FH-34' RH

# STANDARD SPECIFICATIONS

\*\* DENOTES USE OF  
BAR CLAMP W/TABS  
(P/N 186200)

NOTE: FOR PROPER SPIKE HARROW PLACEMENT,  
BE SURE TO COUNT BOTH ROUND AND SQUARE  
SPIKE HOLES.

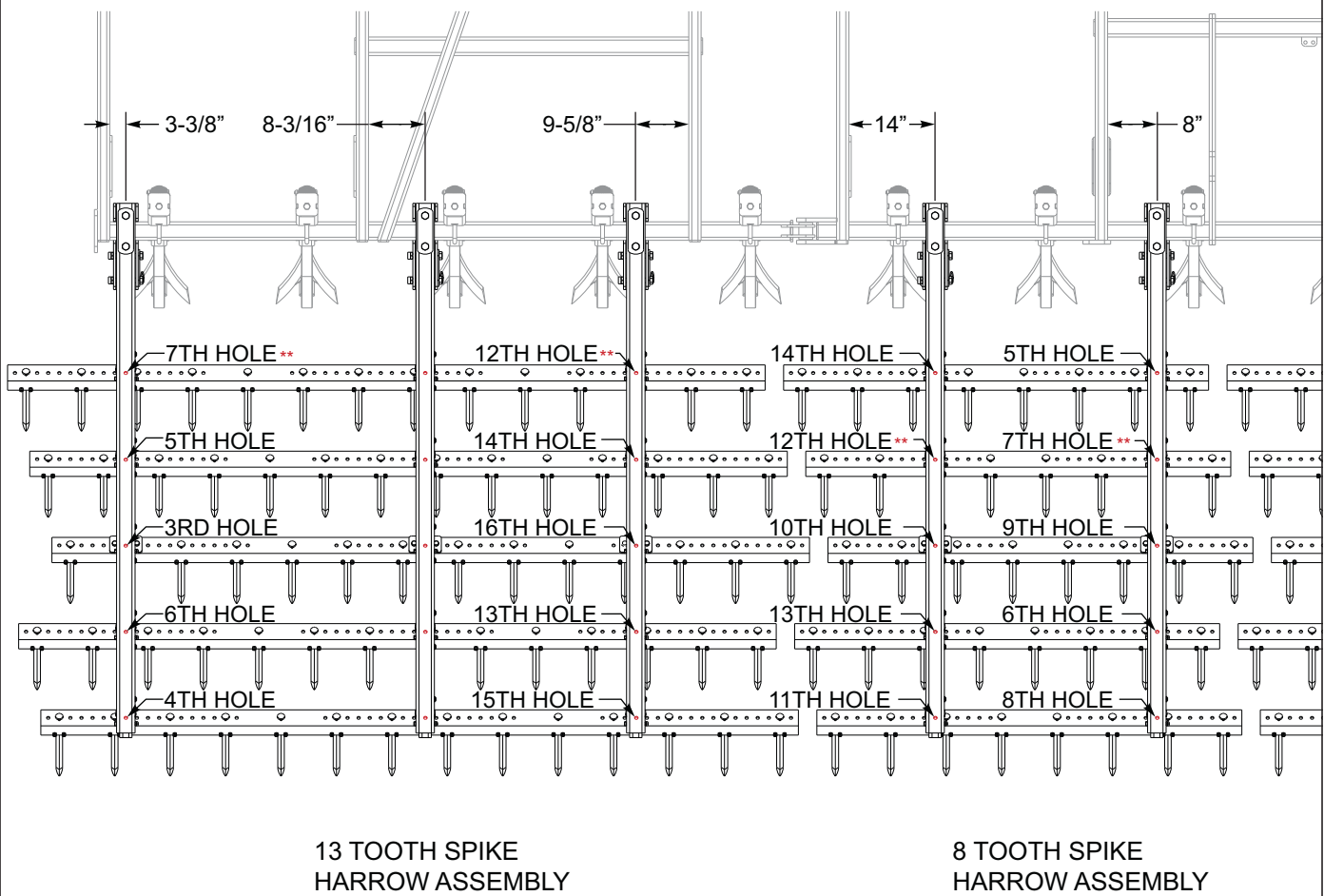

Figure 2-15: 5 Row Spike Harrow Placement 9630FH-30' LH

\*\* DENOTES USE OF  
BAR CLAMP W/TABS  
(P/N 186200)

NOTE: FOR PROPER SPIKE HARROW PLACEMENT.  
BE SURE TO COUNT BOTH ROUND AND SQUARE  
SPIKE HOLES.

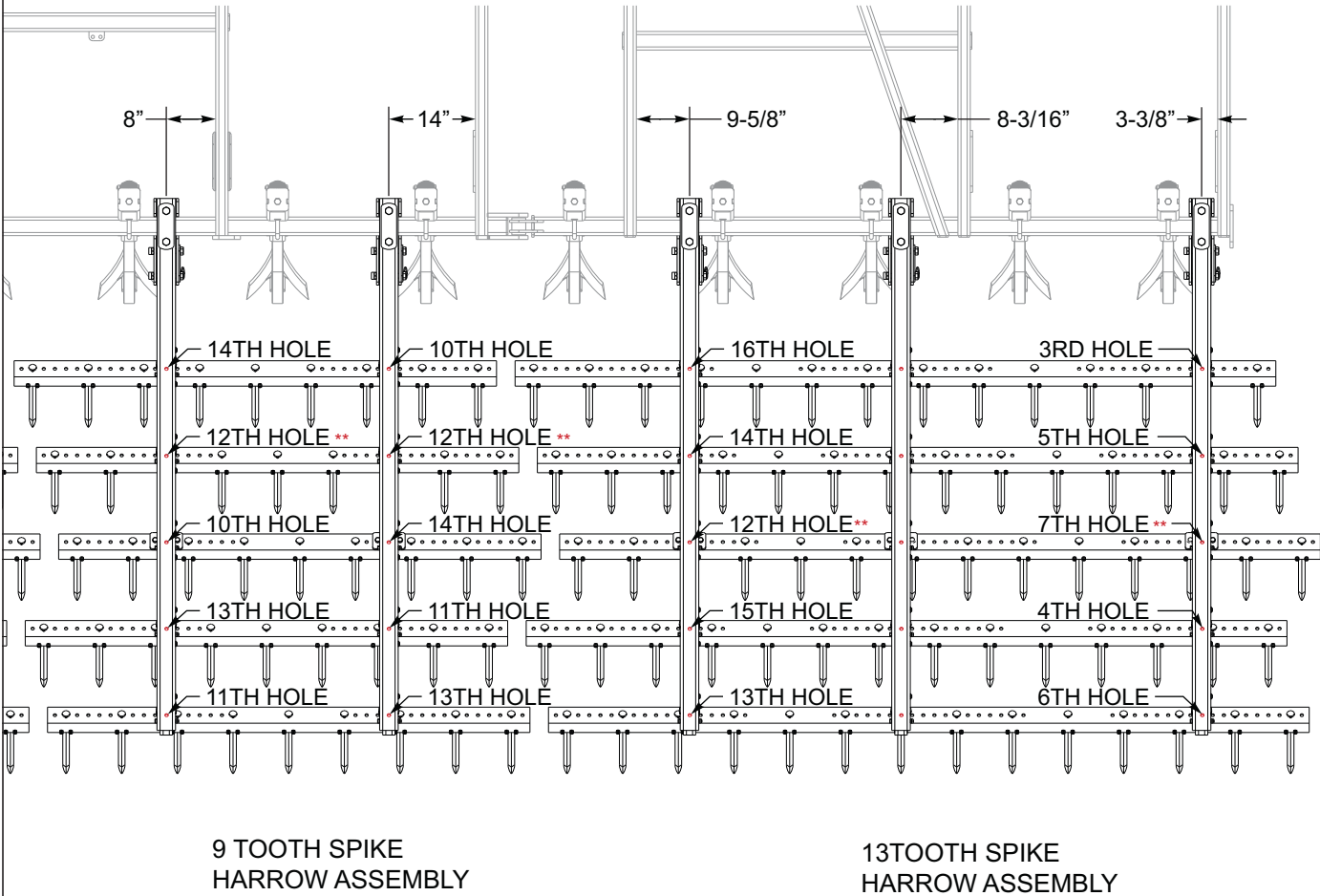

Figure 2-16: 5 Row Spike Harrow Placement 9630FH-30' RH

\*\* DENOTES USE OF  
BAR CLAMP W/TABS  
(P/N 186200)

NOTE: FOR PROPER SPIKE HARROW PLACEMENT,  
BE SURE TO COUNT BOTH ROUND AND SQUARE  
SPIKE HOLES.

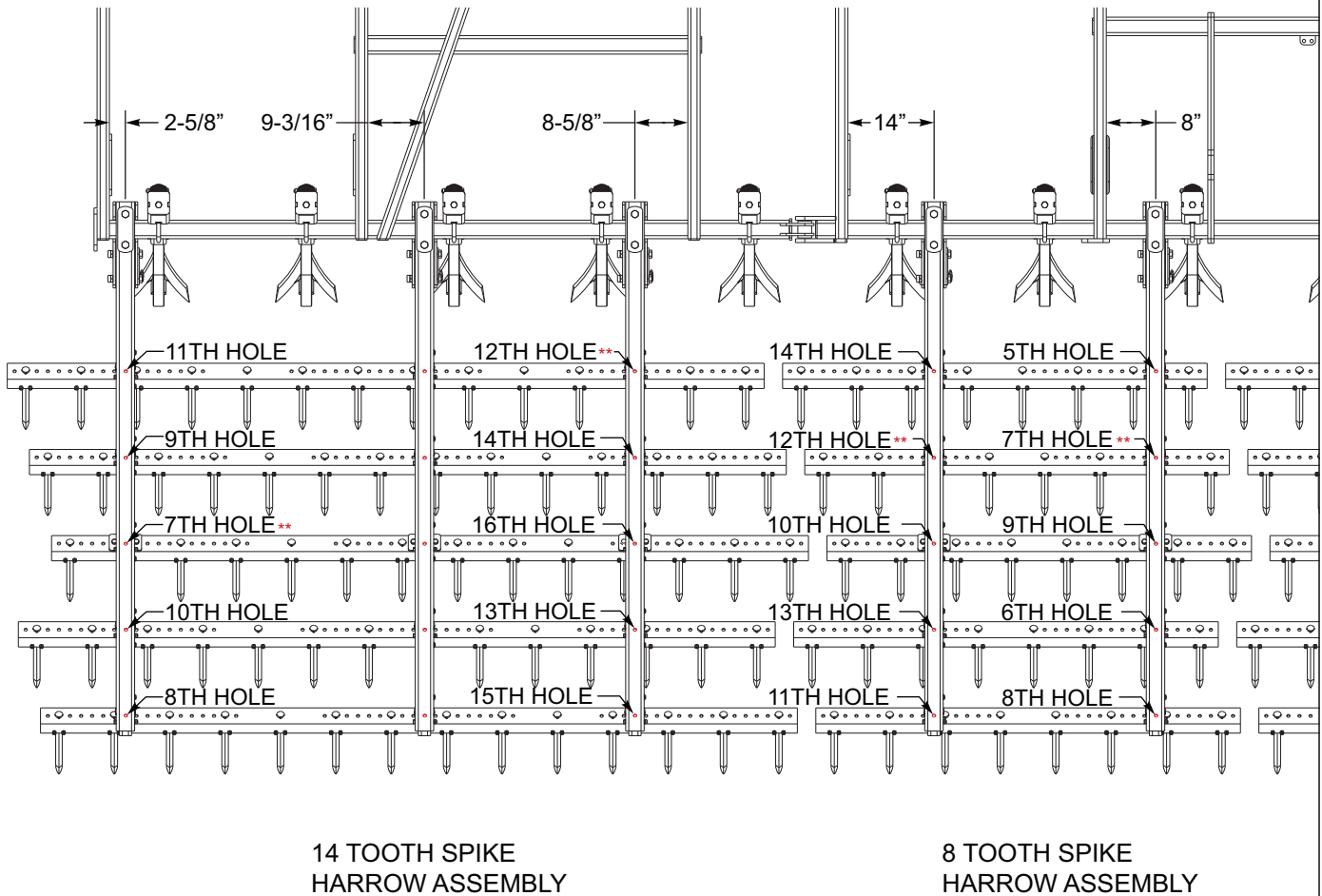

Figure 2-17: 5 Row Spike Harrow Placement 9630FH-32' LH

\*\* DENOTES USE OF  
BAR CLAMP W/TABS  
(P/N 186200)

NOTE: FOR PROPER SPIKE HARROW PLACEMENT.  
BE SURE TO COUNT BOTH ROUND AND SQUARE  
SPIKE HOLES.

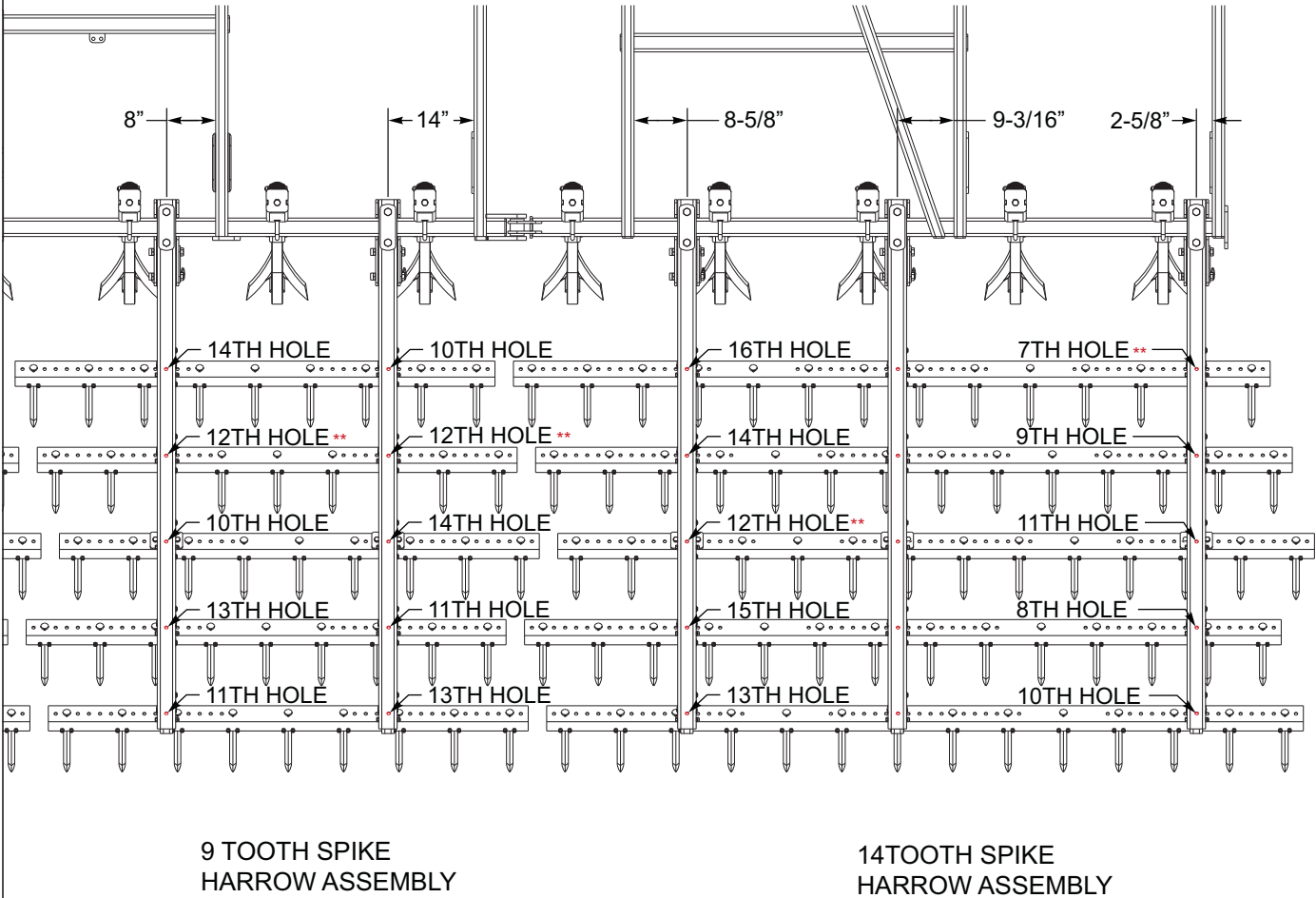
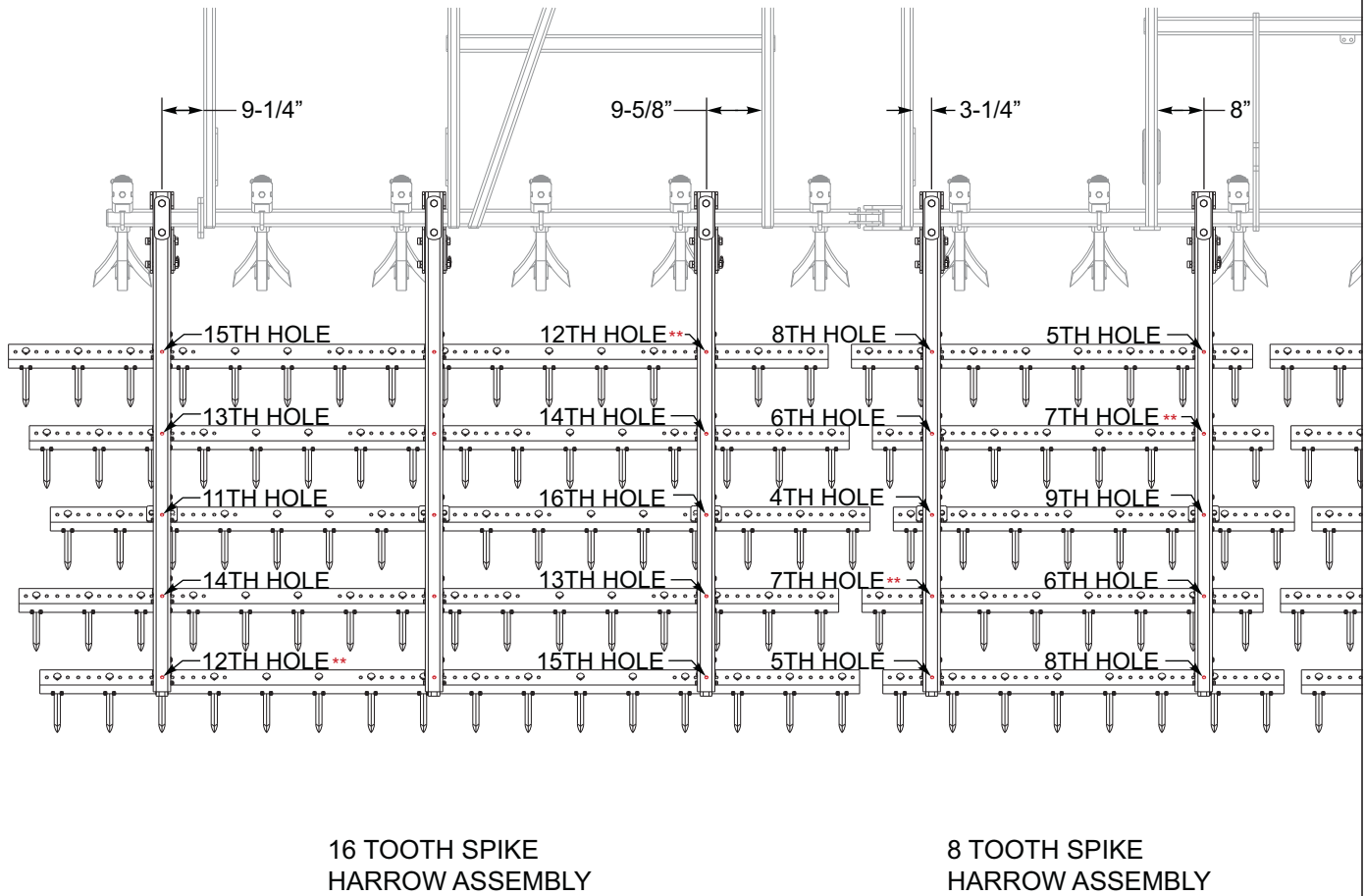

Figure 2-18: 5 Row Spike Harrow Placement 9630FH-32' RH

\*\* DENOTES USE OF  
BAR CLAMP W/TABS  
(P/N 186200)

NOTE: FOR PROPER SPIKE HARROW PLACEMENT.  
BE SURE TO COUNT BOTH ROUND AND SQUARE  
SPIKE HOLES.



**Figure 2-19: 5 Row Spike Harrow Placement 960FH-34' LH**

\*\* DENOTES USE OF  
BAR CLAMP W/TABS  
(P/N 186200)

NOTE: FOR PROPER SPIKE HARROW PLACEMENT.  
BE SURE TO COUNT BOTH ROUND AND SQUARE  
SPIKE HOLES.

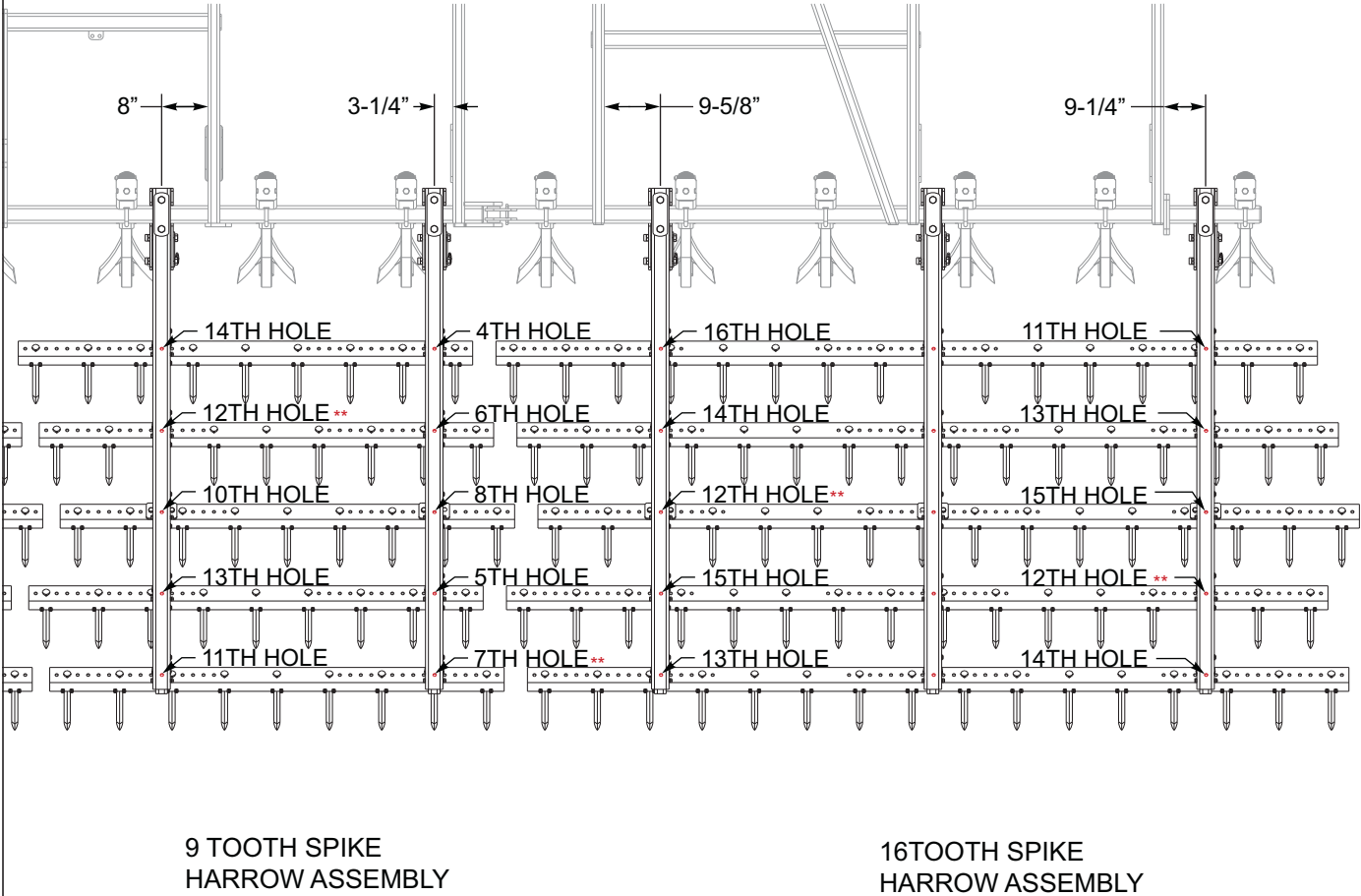
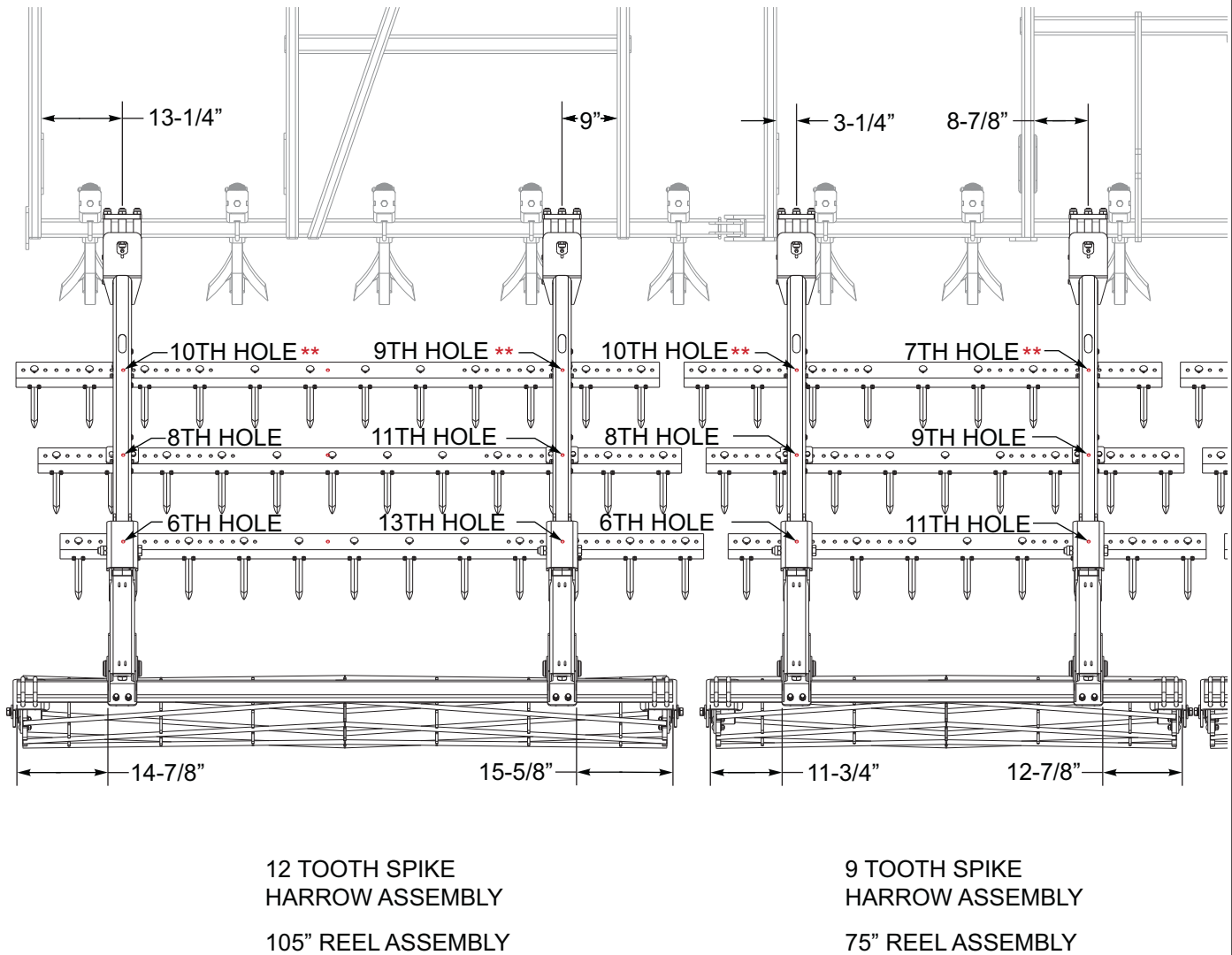

Figure 2-20: 5 Row Spike Harrow Placement 9630FH-34' RH

**STANDARD SPECIFICATIONS**

\*\* DENOTES USE OF  
BAR CLAMP W/TABS  
(P/N 186200)

NOTE: FOR PROPER SPIKE HARROW PLACEMENT.  
BE SURE TO COUNT BOTH ROUND AND SQUARE  
SPIKE HOLES.



**Figure 2-21: 3 Row Spike and Reel Harrow Placement 9630FH-30' LH**



\*\* DENOTES USE OF  
BAR CLAMP W/TABS  
(P/N 186200)

NOTE: FOR PROPER SPIKE HARROW PLACEMENT.  
BE SURE TO COUNT BOTH ROUND AND SQUARE  
SPIKE HOLES.

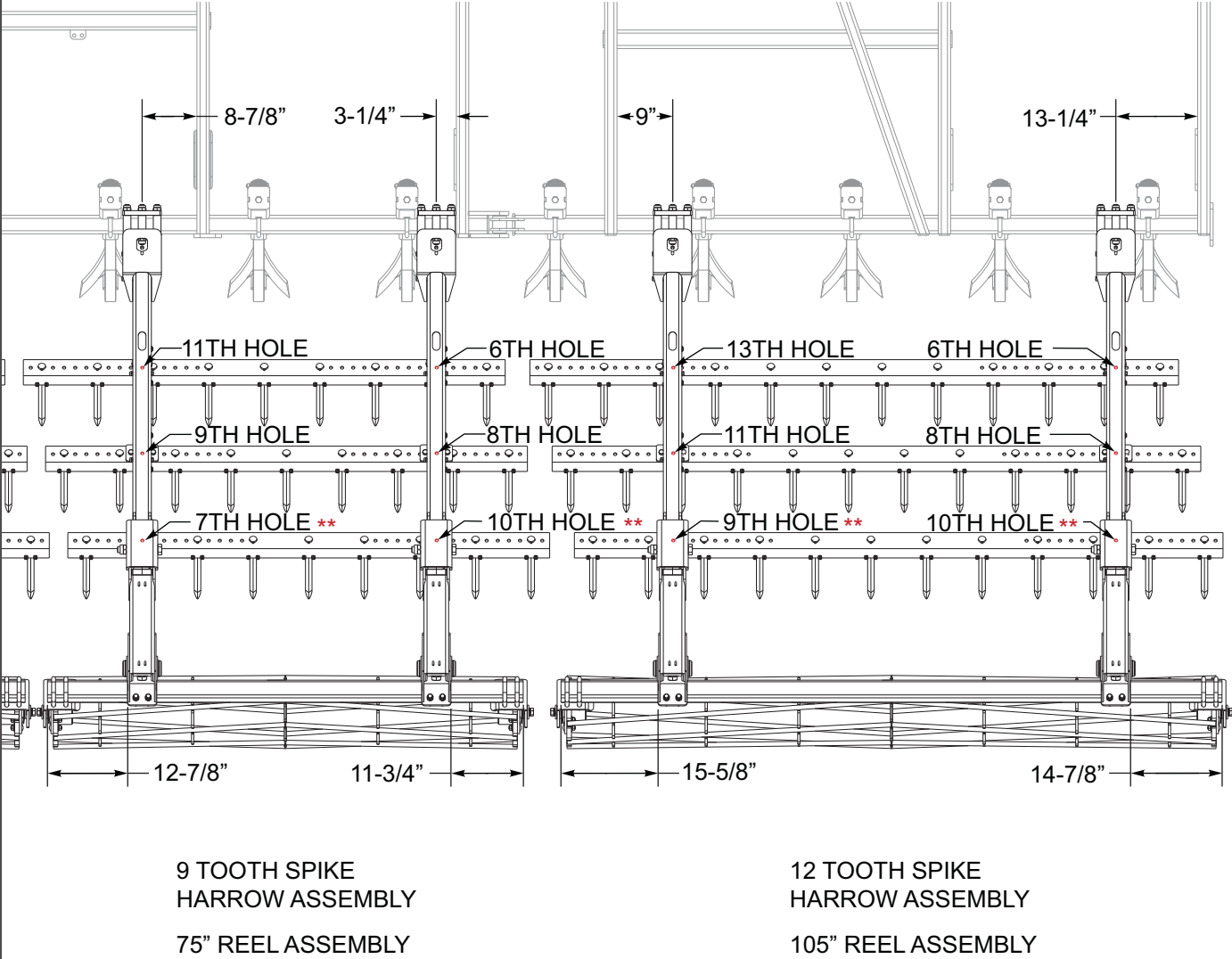
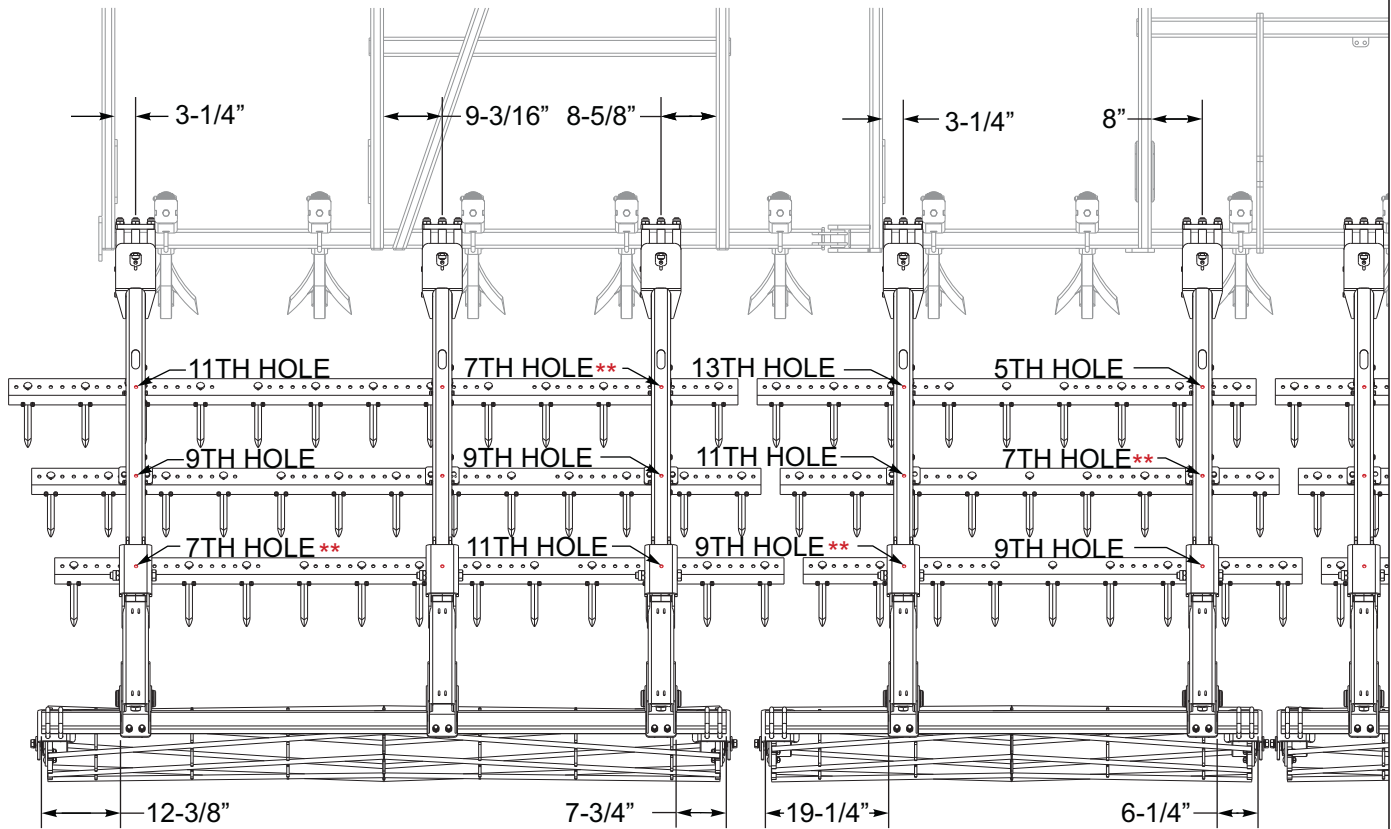

Figure 2-22: 3 Row Spike and Reel Harrow Placement 9630FH-30' RH

# STANDARD SPECIFICATIONS

\*\* DENOTES USE OF  
BAR CLAMP W/TABS  
(P/N 186200)

NOTE: FOR PROPER SPIKE HARROW PLACEMENT.  
BE SURE TO COUNT BOTH ROUND AND SQUARE  
SPIKE HOLES.



13 TOOTH SPIKE  
HARROW ASSEMBLY  
105" REEL ASSEMBLY

9 TOOTH SPIKE  
HARROW ASSEMBLY  
75" REEL ASSEMBLY

Figure 2-23: 3 Row Spike and Reel Harrow Placement 9630FH-32' LH

\*\* DENOTES USE OF  
BAR CLAMP W/TABS  
(P/N 186200)

NOTE: FOR PROPER SPIKE HARROW PLACEMENT.  
BE SURE TO COUNT BOTH ROUND AND SQUARE  
SPIKE HOLES.

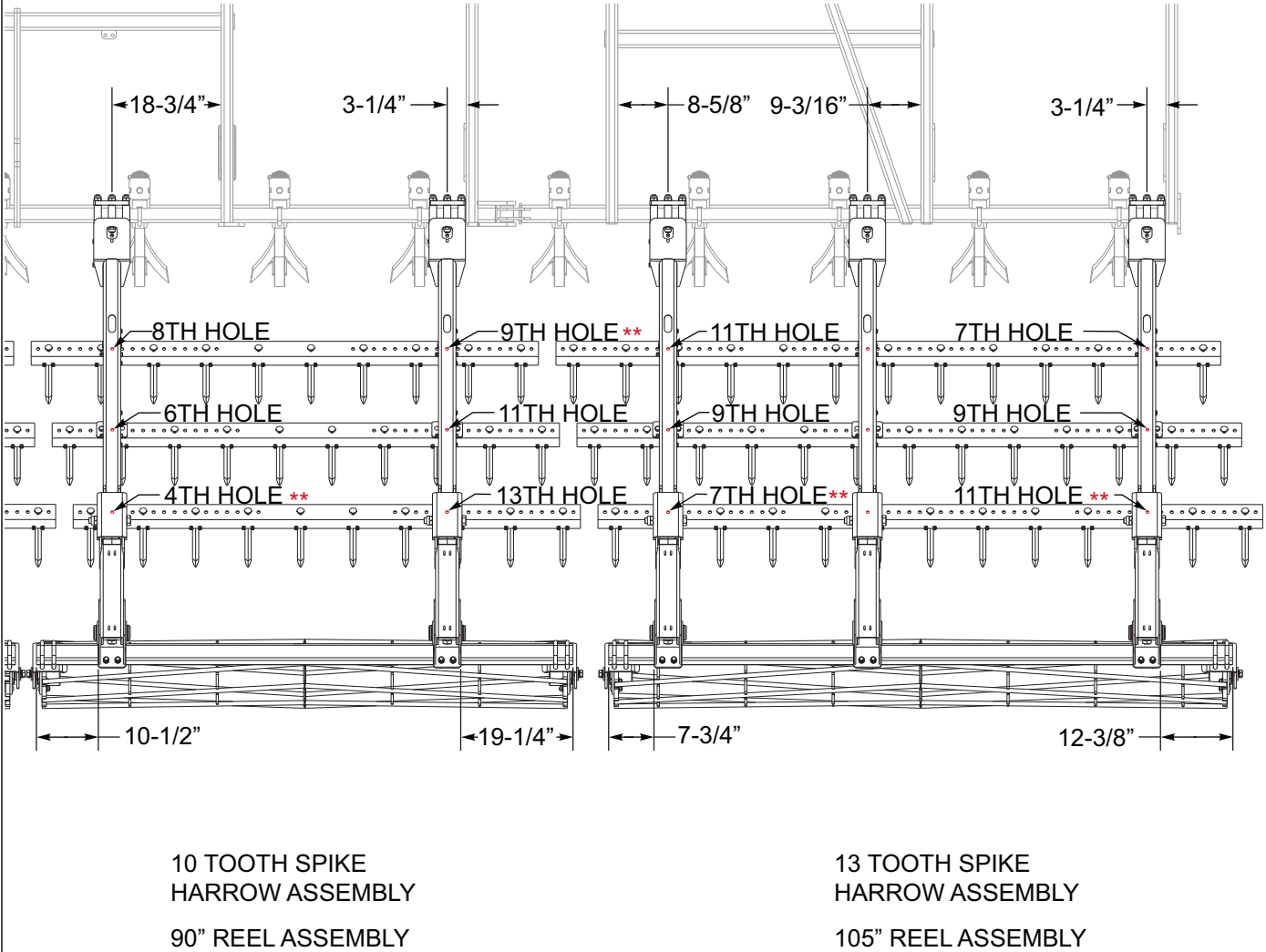
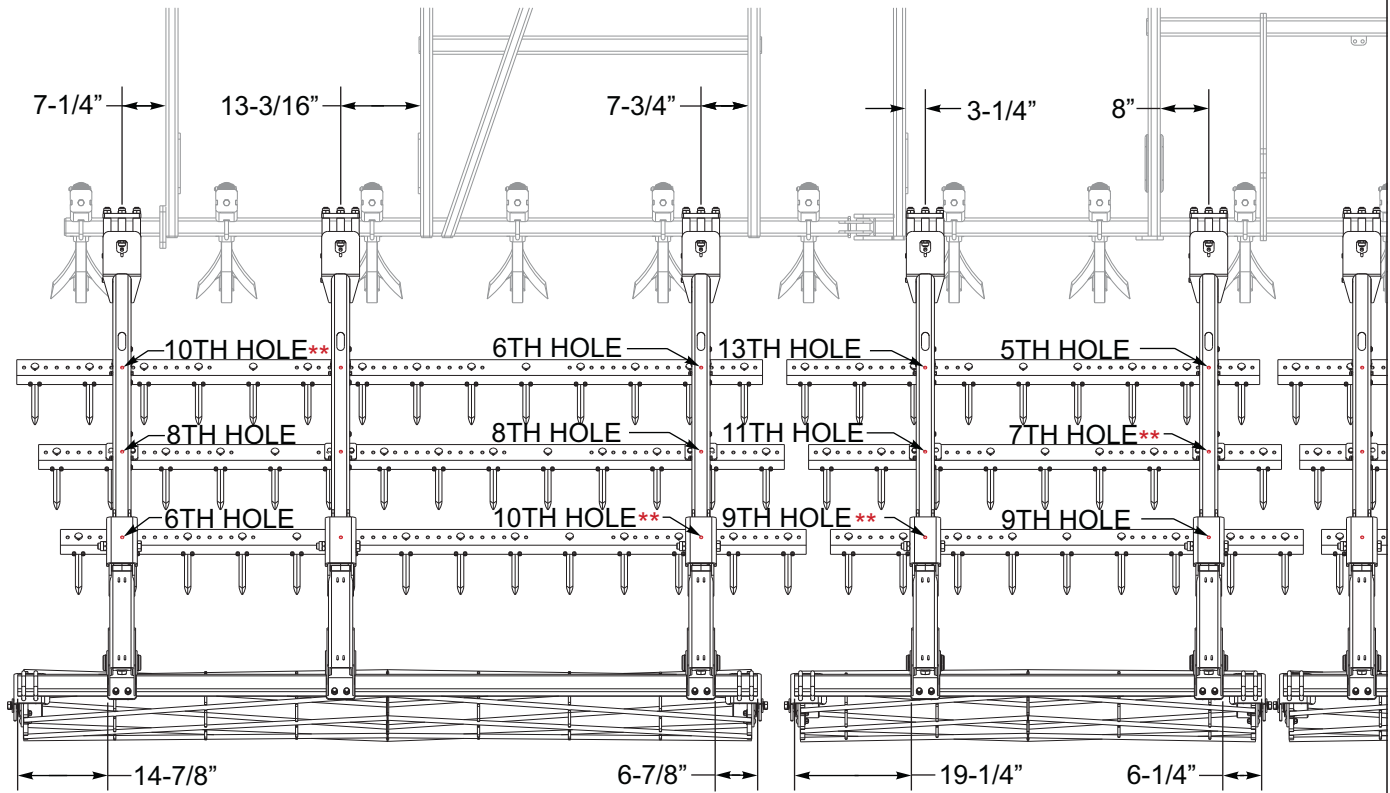

Figure 2-24: 3 Row Spike and Reel Harrow Placement 9630FH-32' RH

# STANDARD SPECIFICATIONS

\*\* DENOTES USE OF  
BAR CLAMP W/TABS  
(P/N 186200)

NOTE: FOR PROPER SPIKE HARROW PLACEMENT.  
BE SURE TO COUNT BOTH ROUND AND SQUARE  
SPIKE HOLES.



14 TOOTH SPIKE  
HARROW ASSEMBLY  
120" REEL ASSEMBLY

9 TOOTH SPIKE  
HARROW ASSEMBLY  
75" REEL ASSEMBLY

Figure 2-25: 3 Row Spike and Reel Harrow Placement 9630FH-34' LH

\*\* DENOTES USE OF  
BAR CLAMP W/TABS  
(P/N 186200)

NOTE: FOR PROPER SPIKE HARROW PLACEMENT.  
BE SURE TO COUNT BOTH ROUND AND SQUARE  
SPIKE HOLES.

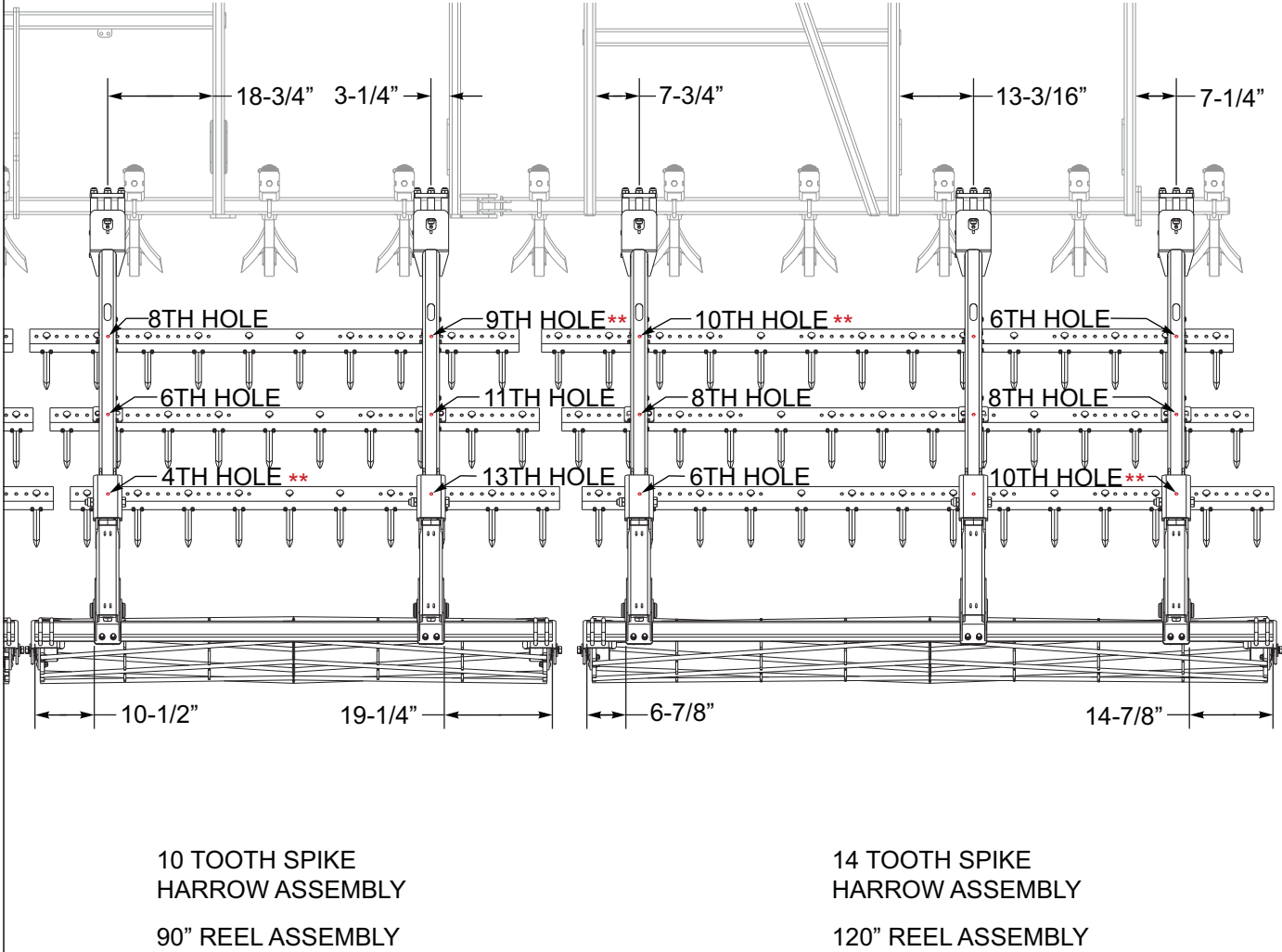

Figure 2-26: 3 Row Spike and Reel Harrow Placement 9630FH-34' RH

# STANDARD SPECIFICATIONS

\*\* DENOTES USE OF  
BAR CLAMP W/TABS  
(P/N 186200)

NOTE: FOR PROPER SPIKE HARROW PLACEMENT.  
BE SURE TO COUNT BOTH ROUND AND SQUARE  
SPIKE HOLES.

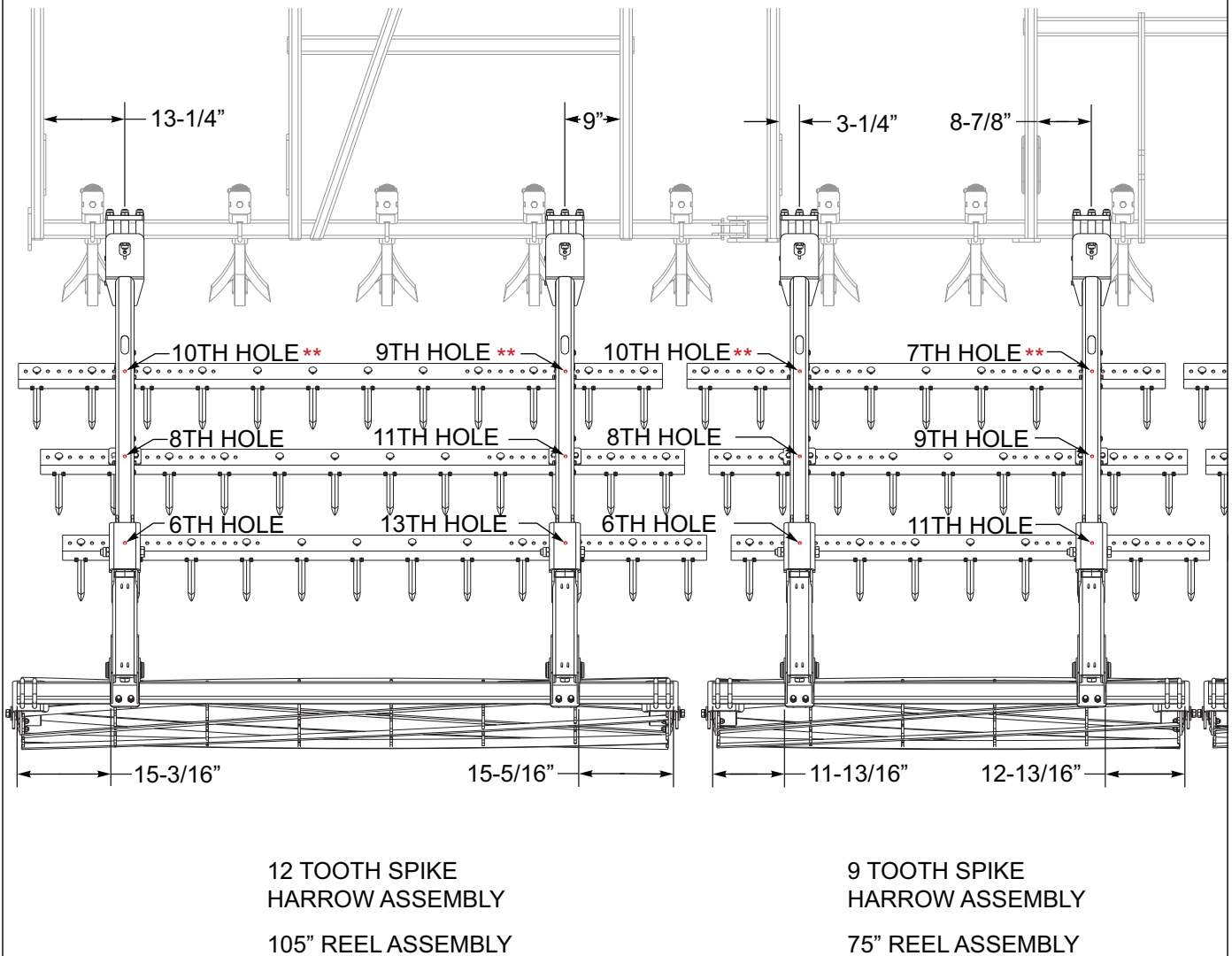

Figure 2-27: 3 RSD and Flat Reel Placement 9630FH-30' LH

\*\* DENOTES USE OF  
BAR CLAMP W/TABS  
(P/N 186200)

NOTE: FOR PROPER SPIKE HARROW PLACEMENT.  
BE SURE TO COUNT BOTH ROUND AND SQUARE  
SPIKE HOLES.

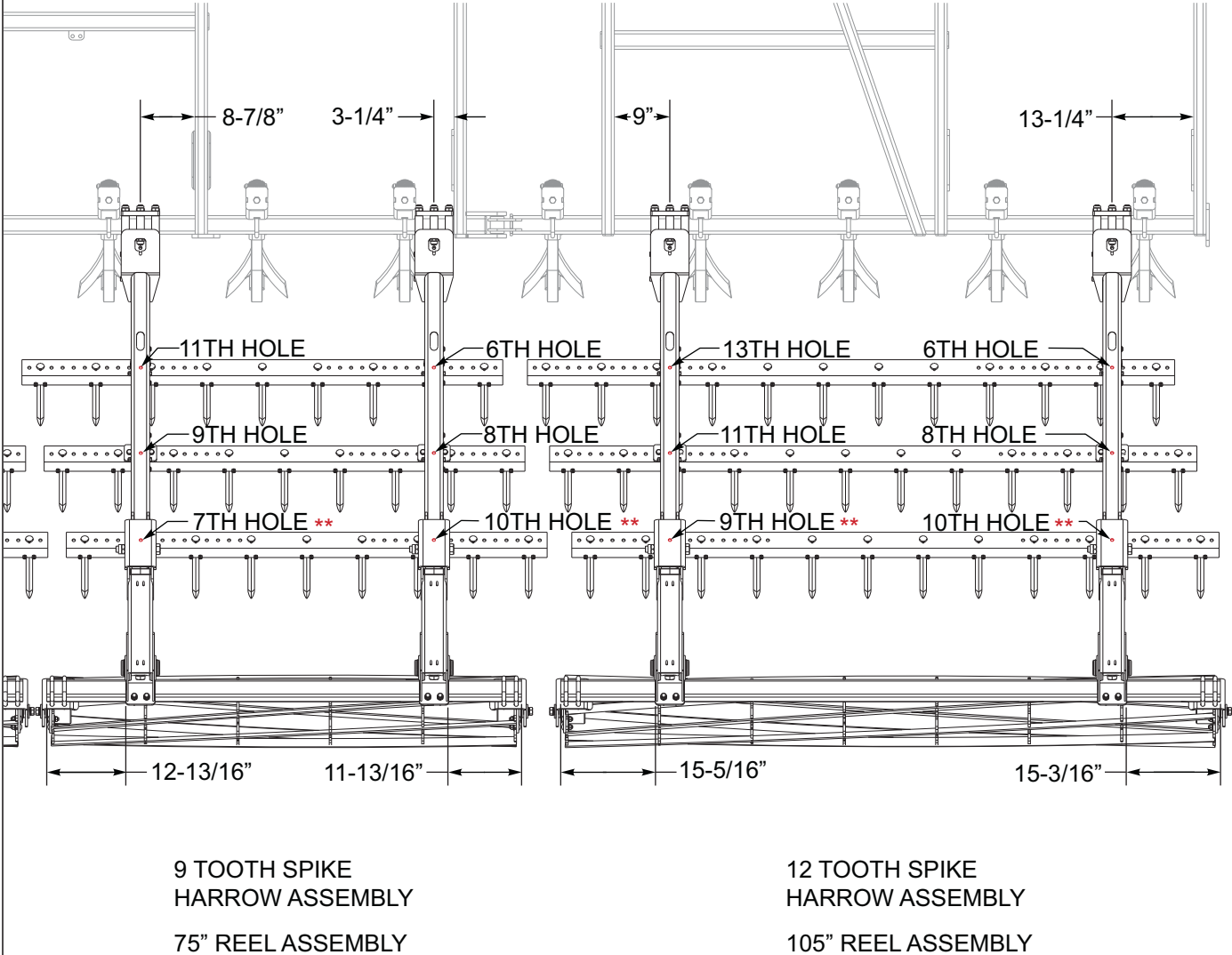

Figure 2-28: 3 RSD and Flat Reel Placement 9630FH-30' RH

# STANDARD SPECIFICATIONS

\*\* DENOTES USE OF  
BAR CLAMP W/TABS  
(P/N 186200)

NOTE: FOR PROPER SPIKE HARROW PLACEMENT,  
BE SURE TO COUNT BOTH ROUND AND SQUARE  
SPIKE HOLES.

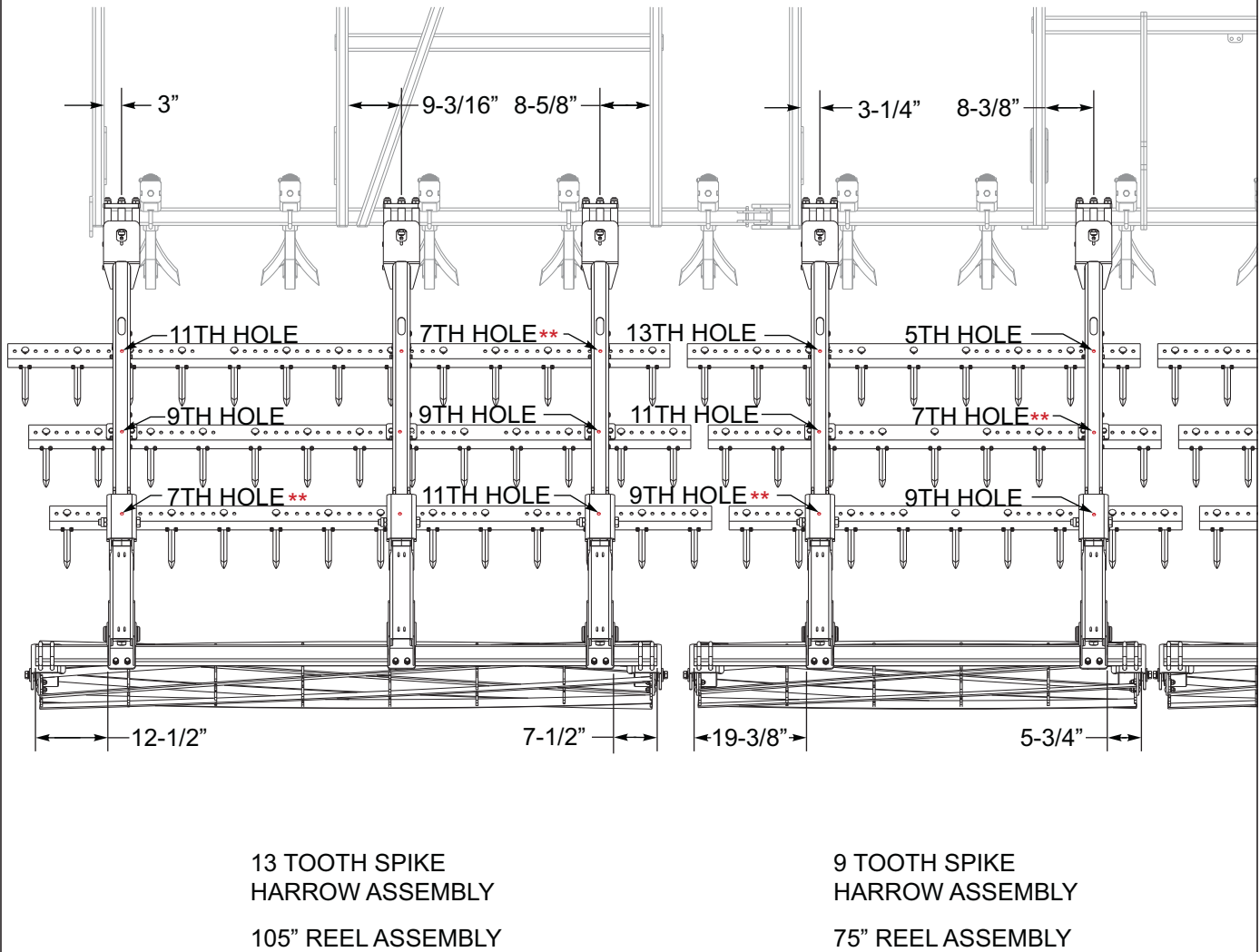

Figure 2-29: 3 RSD and Flat Reel Placement 9630FH-32' LH



\*\* DENOTES USE OF BAR CLAMP W/TABS (P/N 186200)

NOTE: FOR PROPER SPIKE HARROW PLACEMENT BE SURE TO COUNT BOTH ROUND AND SQUARE SPIKE HOLES.

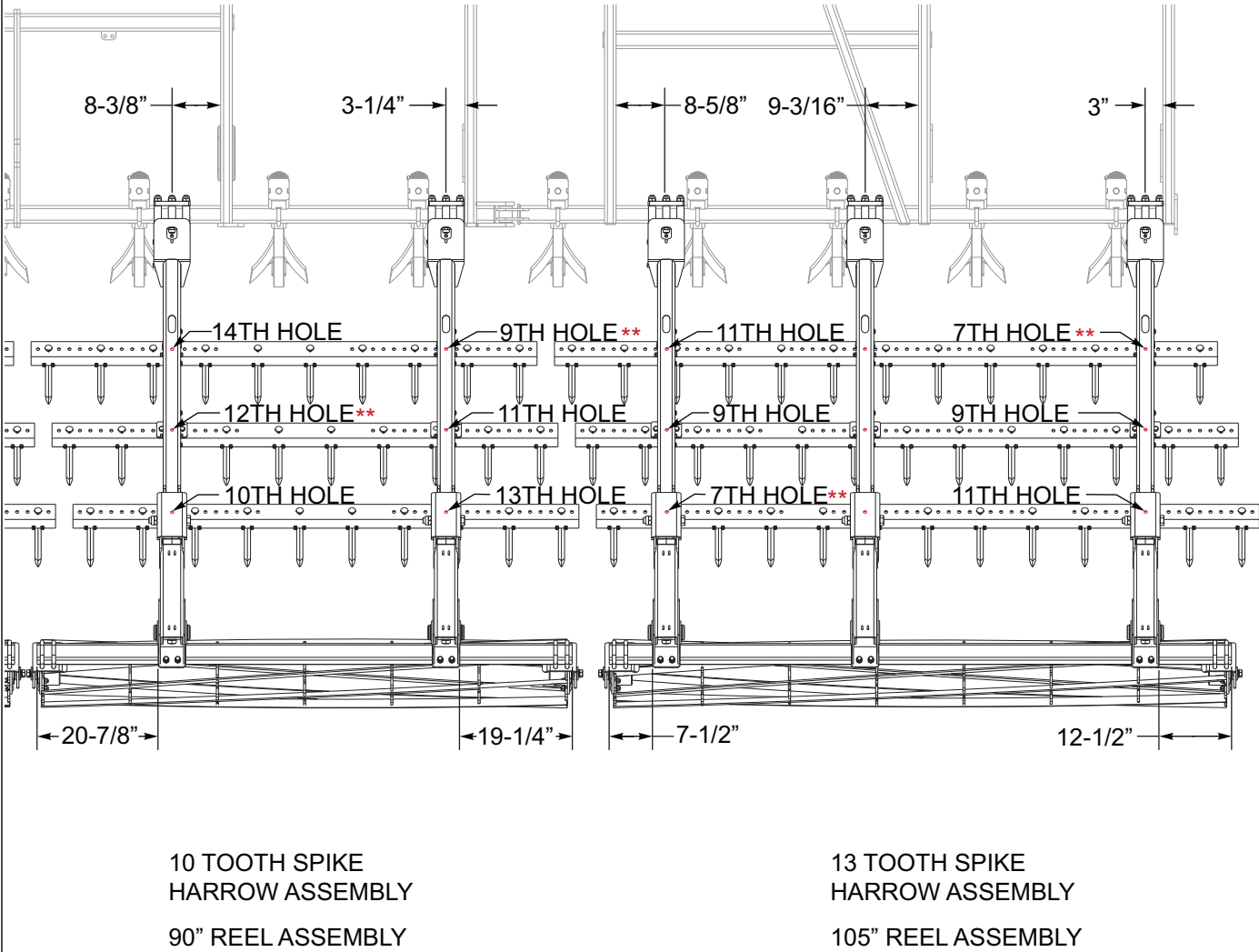
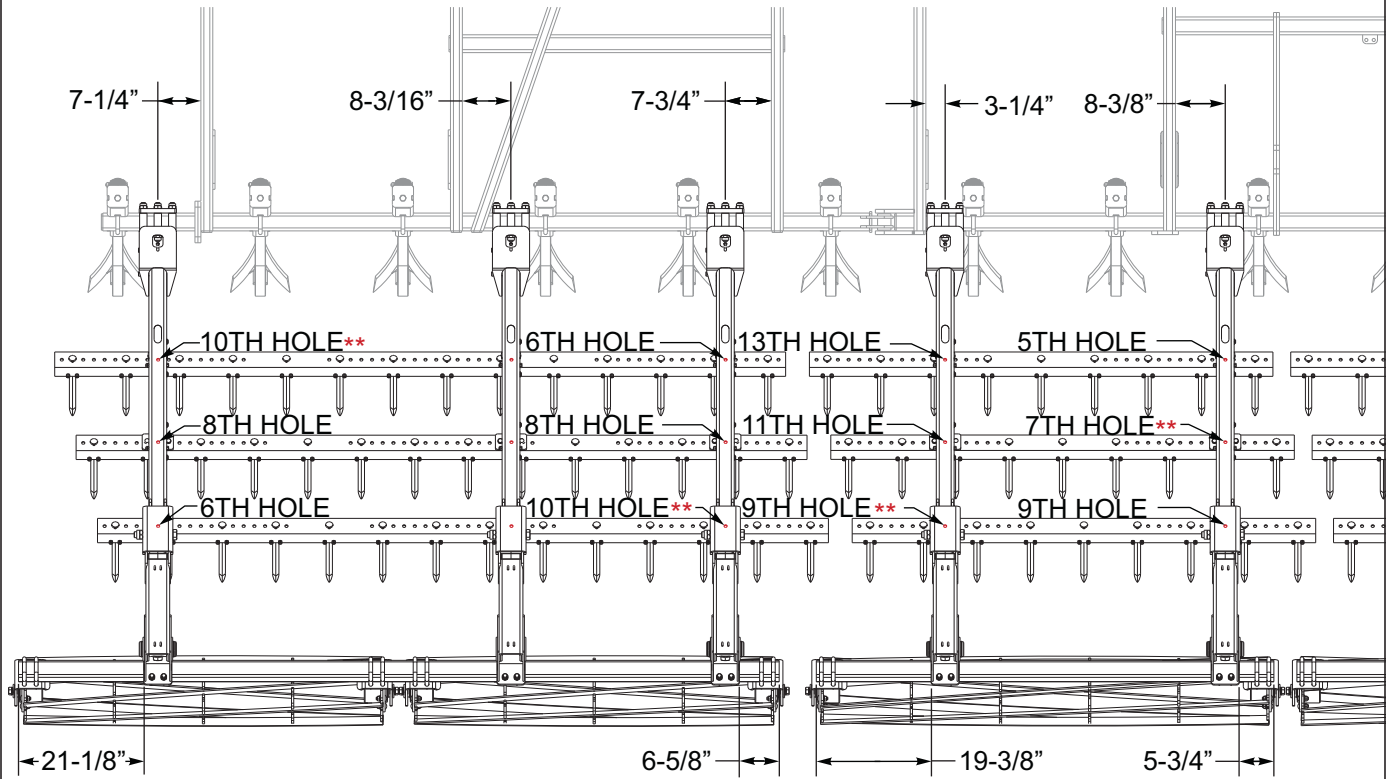

Figure 2-30: 3 RSD and Flat Reel Placement 9630FH-32' RH

**STANDARD SPECIFICATIONS**

\*\* DENOTES USE OF  
BAR CLAMP W/TABS  
(P/N 186200)

NOTE: FOR PROPER SPIKE HARROW PLACEMENT,  
BE SURE TO COUNT BOTH ROUND AND SQUARE  
SPIKE HOLES.



14 TOOTH SPIKE  
HARROW ASSEMBLY  
120" REEL ASSEMBLY

9 TOOTH SPIKE  
HARROW ASSEMBLY  
75" REEL ASSEMBLY

**Figure 2-31: 3 RSD and Flat Reel Placement 9630FH-34' LH**

\*\* DENOTES USE OF BAR CLAMP W/TABS (P/N 186200)

NOTE: FOR PROPER SPIKE HARROW PLACEMENT BE SURE TO COUNT BOTH ROUND AND SQUARE SPIKE HOLES.

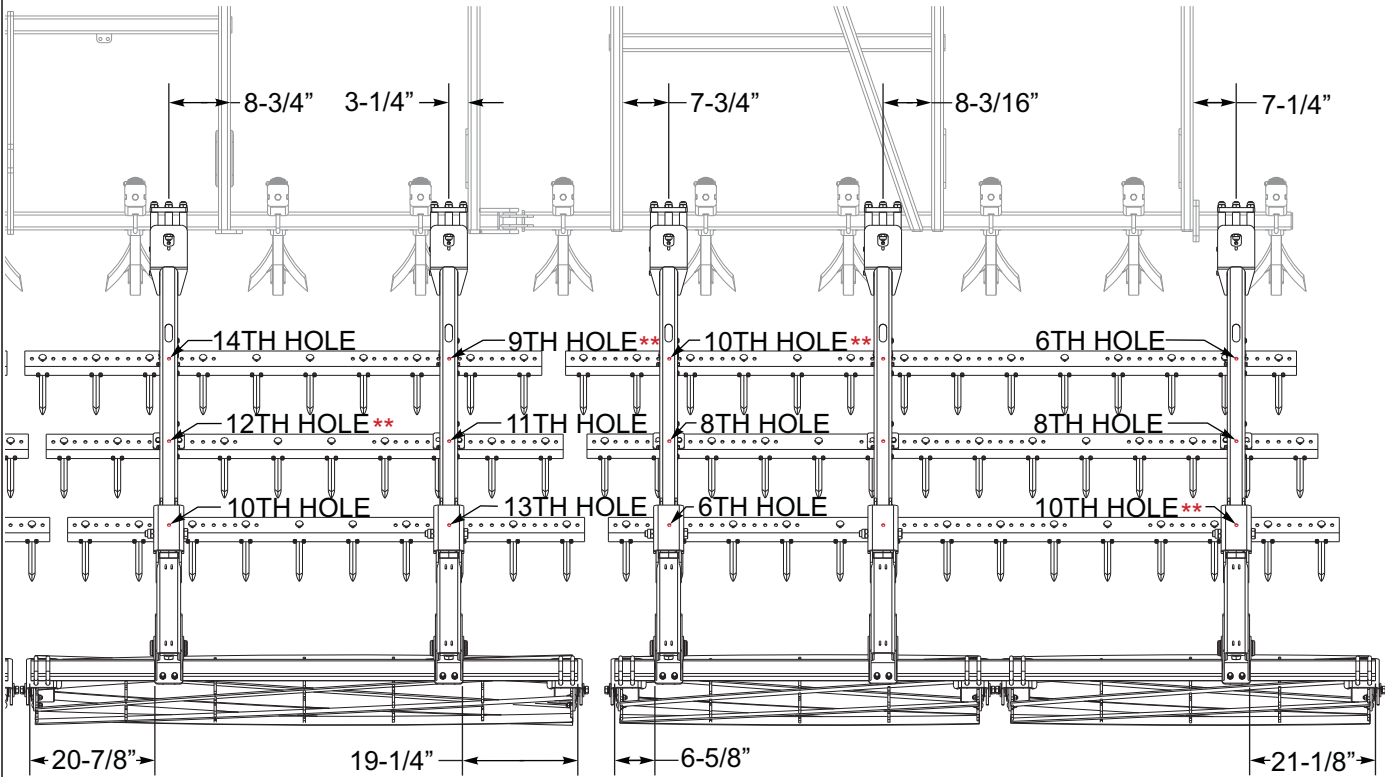

10 TOOTH SPIKE HARROW ASSEMBLY  
90" REEL ASSEMBLY

14 TOOTH SPIKE HARROW ASSEMBLY  
120" REEL ASSEMBLY

Figure 2-32: 3 RSD and Flat Reel Placement 9630FH-34' RH



## Assembly Instructions

It is very important that your new 9630FH Field Cultivator be properly assembled, adjusted and lubricated before use. Illustrations in this section show proper assembly procedures. Remove paint from grease fittings. Replace any grease fittings that are damaged or missing. Be sure to return screws, clips, etc., to their original locations.

To insure alignment of assemblies, **leave the nuts loose until completion** of final assembly. Use lock washers or flat washers as specified. Spread all cotter pins.

**After completion** of final assembly, **tighten all nuts evenly** to prevent misalignment, distortion or binding. Tighten all screws and nuts to the recommended torques shown in [Table 2-1](#) and [Table 2-2](#).



### WARNING

**Do not attempt to lift heavy parts (such as the frame, rock shaft, and pull hitch) manually. Use a hoist or a forklift to move these parts into position.**



### DANGER

**To prevent accidental lowering:**

- 1. All hydraulically elevated equipment must be locked out using the cylinder lockouts.**
- 2. Lower equipment to the ground while servicing or when it is idle.**

**Failure to take measures to prevent accidental lowering may result in serious personal injury or death.**



### CAUTION

**Be sure to bleed the hydraulic system of all air in lines after installation. Failure to bleed the system of all air can result in permanent equipment damage.**

### Center Frame Assembly- 9630FH

#### IMPORTANT

Read all safety precautions at the front of the section before attempting any of the following procedures.



#### WARNING

Do not attempt to lift heavy parts (such as the frame and rock shaft) manually. Use a hoist or a fork lift to move these parts into position.

1. Position the two center frame halves side-by-side on the ground.
2. Bolt the two center frame halves together using 5/8 x 2 bolts and locknuts *See Figure 3-1*.
3. Now place the frame assemblies on stands 36" off the ground.
4. Remove any shank assemblies or extensions that have been turned around or mounted inside the frame for shipping, and reposition, *See Figures 2-2 through 2-6* in "STANDARD SPECIFICATION" section for shank placement.
5. Install a UHMW bearing between both inner bearing locators around the center lift assembly.
6. Insert a UHMW bearing into each bearing cap and install the cap and bearing over the end of center lift assembly.
7. Raise the center lift assembly into the center frame and attach each end bearing cap to the center frame with 5/8 x 4 bolts and lock nuts
8. Install the two inner lift bearing mounts with 5/8 x 2 bolts and lock nuts.
9. Attach the bottom end of the cylinder lift arms to the outside of bearing housing mounts with 1 x 2-3/4 bolts and 1 locknuts.
10. Connect the top end of the cylinder lift arms to the radius rod. Include the hose mount when installing the 1 x 4 bolt and locknut. Initially, set the radius rod to 54" pin centers for the center frame.
11. Install the two 4x10 master cylinders to the cylinder lift arms, and the center lift. Install the cylinders with the rod end down, and with rephasing cap to the top. Use a 1" welded head pin, 1" machine bushing on cotter pin on the rod end of the cylinder. Insert the pin so the head will be facing the tire. Install the transport locks in the storage locations on back of the lift cylinder plates with L-pins and hairpin clips.
12. Connect the rear of the gauge wheel lift tubes to the center lift with 1-1/4 x 2-3/4 step pin, 1/2 x 2-1/4 roll pin, and 1 locknut. Insert the pin so the nut is away from the lift cylinder.
13. All lifts and hubs/spindle come already assembled from the factory.
14. Install the 320/70 R15 tire/wheel assemblies to all hub/spindle assemblies using 5/8 wheel nuts.
15. Install the 8 port manifold to 2 hole plate toward front of center frame assembly with 1/2 x 3-1/2 bolts and 1/2 lock nuts *See Figure 3-1*.
16. Install the lift/fold manifold assembly on 2 hole plate on rear of center frame tube using 1/2 x 3-1/2 bolt and 1/2 lock nut *See Figure 3-1*.

#### NOTE

*Make sure the center lift will rotate freely in the center frame after it is assembled.*

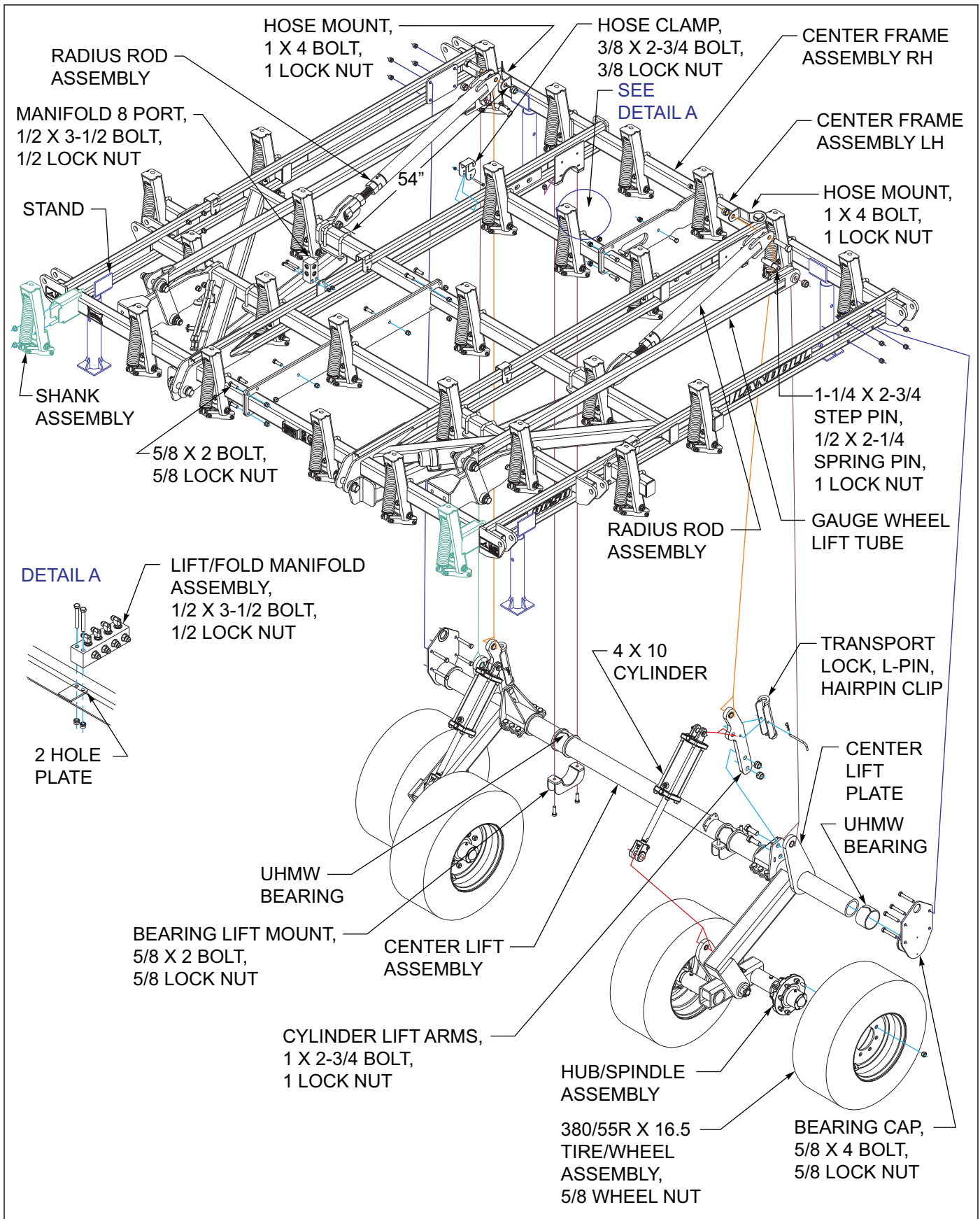

Figure 3-1: Center Frame Assembly

## Center Frame Fold and Depth Control Assembly

### IMPORTANT

Read all safety precautions at the front of the section before attempting any of the following procedures.



### WARNING

Do not attempt to lift heavy parts (such as the frame and rock shaft) manually. Use a hoist or a fork lift to move these parts into position.

1. Attach the front & rear fold cylinder mounts to the top of the center frame using 5/8 x 3-11/16 x 5-1/2 u-bolts and lock nuts *See Figures 3-2*. The rectangular hole in the front cylinder mount will be mounted to the left side of the center frame.
2. Attach the DCV valve mount to the front of the fold cylinder mount with the rectangular hole. Use a clamp plate on the rear side of the fold cylinder mount, and fasten with 3/8x2 bolts and lock nuts.
3. Insert a slide pad into the bottom of the hole in the valve mount.
4. Install a 90 deg elbow in the back side (opposite the button) of the depth control valve. Fasten the valve and fitting to the valve mount using 5/16x2-1/4 bolts and lock nuts.
5. Attach the depth control mount (164205) to the center lift using 3/8 x 1-1/4 bolts and 3/8 lock nuts.
6. Insert the depth stop tube assembly through the depth control mount. Attach the rear of the tube assembly to the depth control mount on the top of the center lift assembly using a 5/8 x 2-1/2 bolt and lock nut. Do not over-tighten this bolt as the tube must pivot freely on the depth control mount.
7. Using 5/8 x 3-11/16 x 5-1/2 u-bolts and lock nuts, attach the wing stabilizer to the top of the center frame.



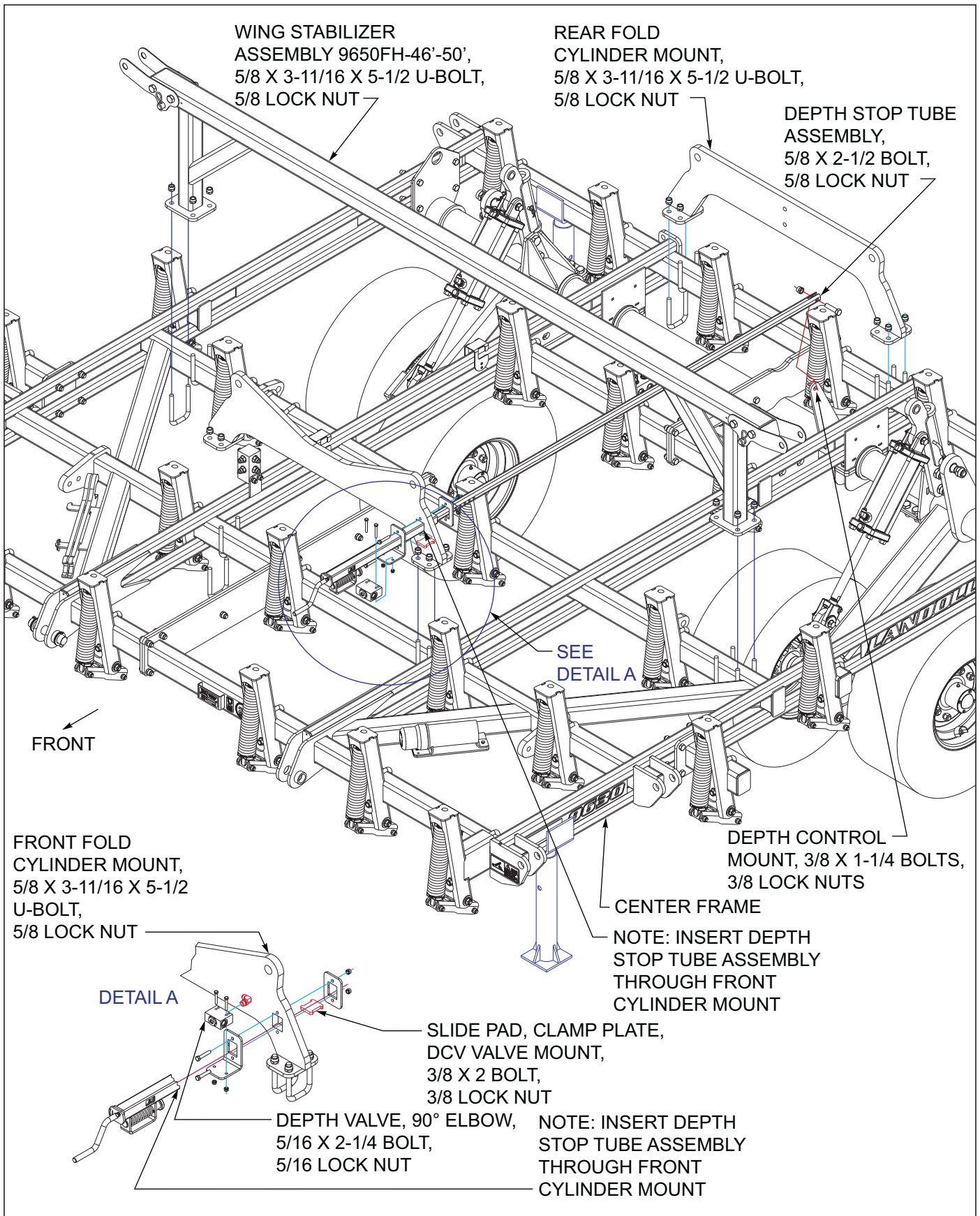

Figure 3-2: Center Frame Fold & Depth Control Assembly

### Gauge Wheel Assembly Center

#### IMPORTANT

Read all safety precautions at the front of the section before attempting any of the following procedures.



#### WARNING

Do not attempt to lift heavy parts (such as the pull hitch) manually. Use a hoist or a fork lift to move these parts into position.

1. Remove the shipping u-bolts and nuts from front of the gauge wheel extension mounts [See Figure 3-3](#).
2. Attach the gauge wheel assemblies to the front of the center frame with 3/4 x 5-1/2 bolts and 5/8 lock nuts.
3. Connect the radius rod assembly to the front of the gauge wheel lift tube with the installed 1 x 7-1/2 bolts and 1 lock nut. Connect the front of the radius rod assembly to the top of the gauge wheel links with 1 x 7-1/2 bolt and 1 locknut. Initially set the radius rod assembly to 21" centers.
4. Install 6-bolt tire/wheel assemblies on the gauge wheel assemblies.

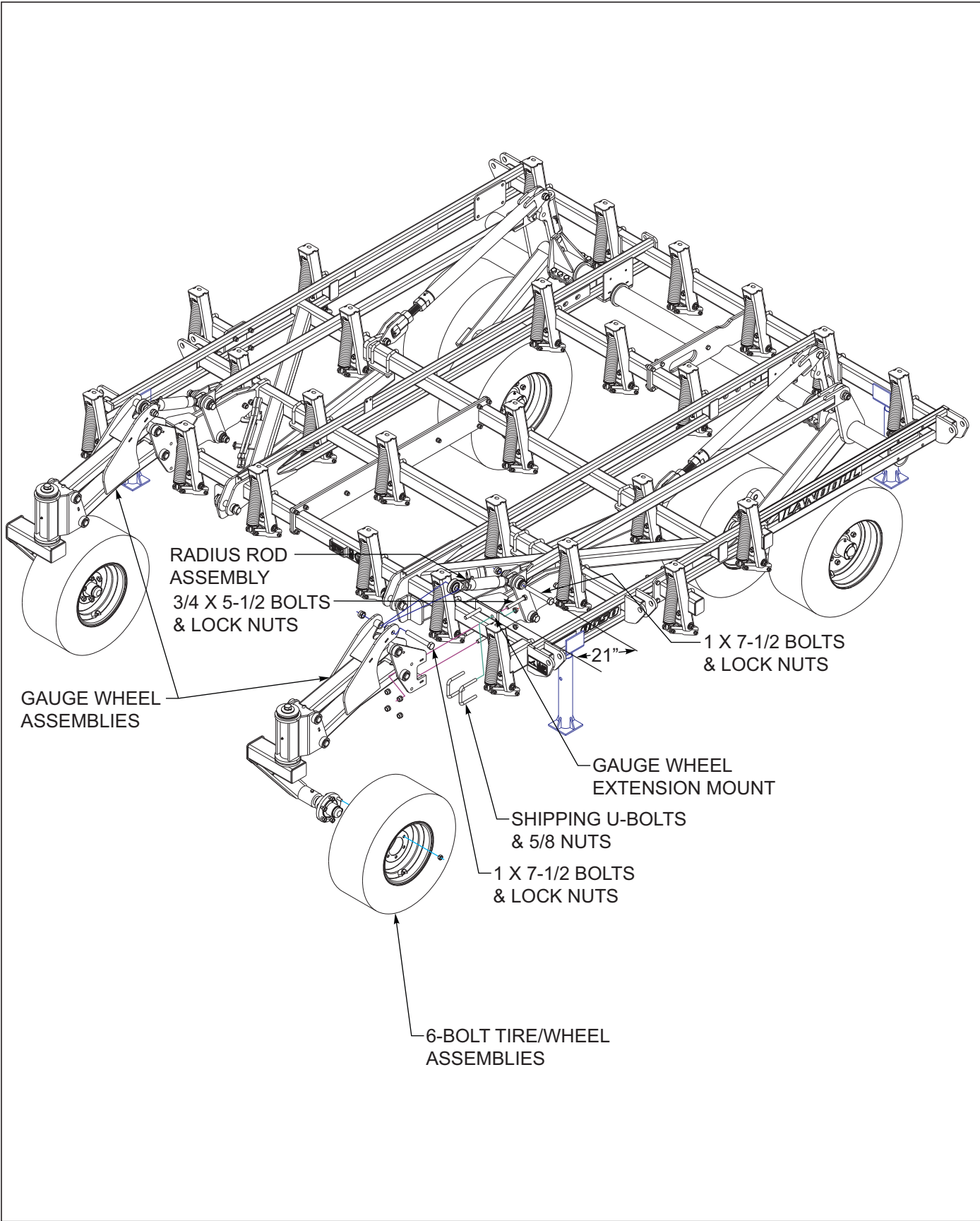

Figure 3-3: Gauge Wheel Assembly Center

### Hitch Assembly

#### IMPORTANT

Read all safety precautions at the front of the section before attempting any of the following procedures.



#### WARNING

Do not attempt to lift heavy parts (such as the pull hitch) manually. Use a hoist or a fork lift to move these parts into position.

1. Connect hitch assembly to the front of the center frame using 1-7/16 x 7-1/4 hitch pin, machine busings, and 1/2 x 2-1/2 slotted spring pin [See Figure 3-4](#).
2. Install the tongue jack in the forward mounting tube and rotate to parking position to support the front of the hitch.
3. Insert a 3/4-10 x 7 hex bolt into the hose holder tube on the hitch from the bottom side so the threads point upward. Hold in place with a 3/4-10 flange nut with the flange pointing upward as well. Do not tighten this cap screw, so the hose holder bracket may pivot freely in this joint.
4. Slide the hose holder bracket over the screw and secure with another 3/4 flange nut.
5. Install a 3/8-16 x 3-1/2 all-thread screw in the front of the hose holder bracket and secure with a 3/8-16 hex nut.
6. Slide the hose holder clamp over the 3/8" screw and loosely start the wing nut on top of the clamp. Hydraulic hoses will be routed through the clamp after assembly.
7. Attach the store-a-way harness to the bottom side of hose holder bracket using 1/4-20 x 1 hex bolts and 1/4-20 lock nuts.

#### NOTE

*The clamp has two sides, so that extend hoses can be located on one side and retract hoses can be located on the other side for reference.*

7. Attach the store-a-way harness to the bottom side of hose holder bracket using 1/4-20 x 1 hex bolts and 1/4-20 lock nuts.

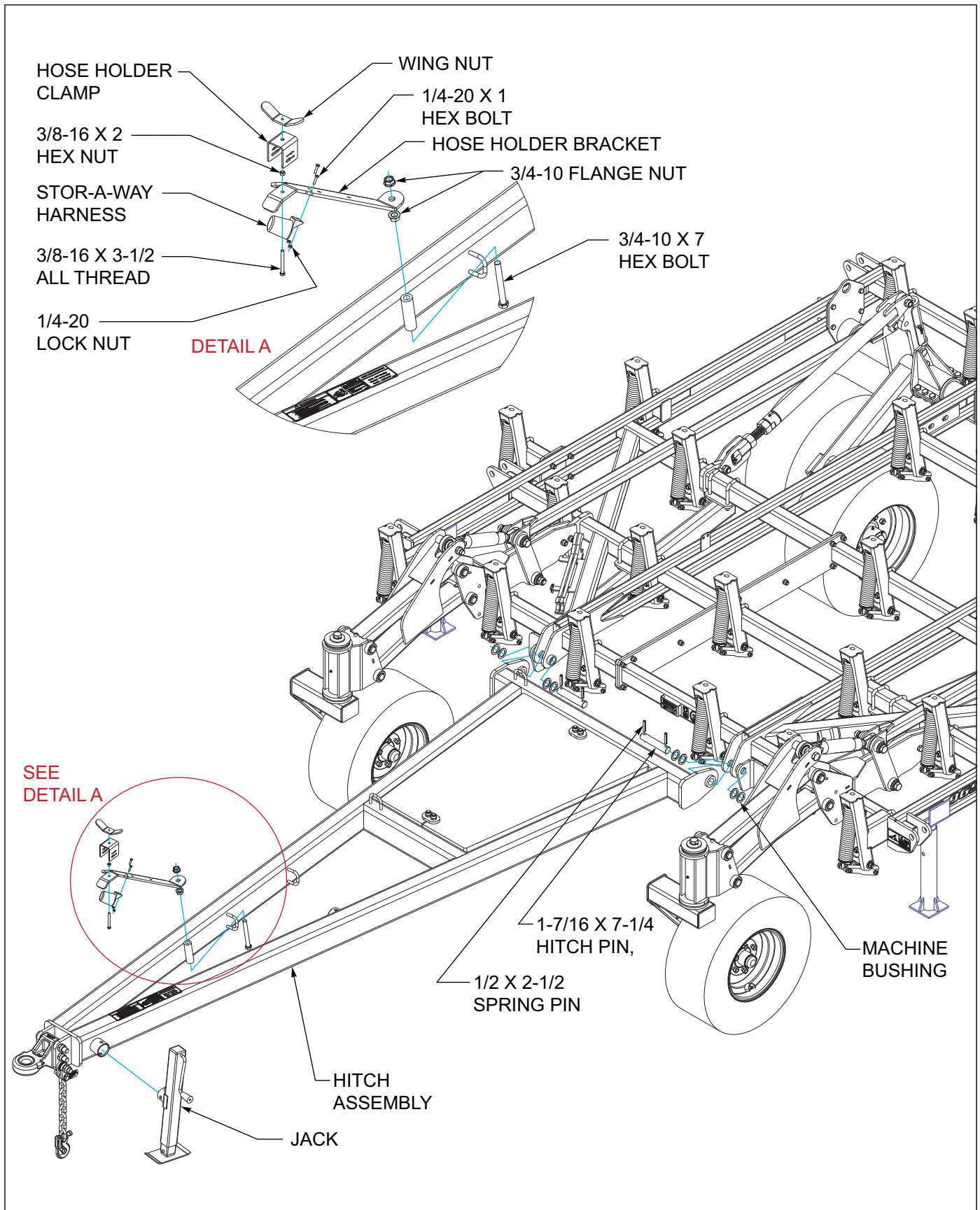

Figure 3-4: Hitch Assembly

### Wing Frame Assembly

1. Attach wing frames to center frame using 1-1/4 flange bearings, flat washers, 1-1/4 x 6-1/8 pin and 5/16 x 2-1/2 spring slotted pins [See Figure 3-5](#).
2. Support the outer ends of the inner wing frames with stands approximately 36" tall.
3. Remove any shank assemblies or extensions that have been turned around or mounted inside the frame for shipping, and reposition. **(SEE PAGE 2-4)** shank placement.
4. Connect the radius rod to the cylinder lift arm, and the cylinder ends which have been disconnected for shipping.
5. Install the 6-bolt tire/wheel assemblies on the inner wing lift assembly.

#### **NOTE**

*All tire/wheel assemblies are mounted with the valve stem facing outward.*

### Wing Gauge Wheel Installation

1. Remove the shipping u-bolts and nuts from front of the gauge wheel extension mounts [See Figure 3-5](#).
2. Attach the gauge wheel assemblies to the front of the center frame with 3/4 x 5-1/2 bolts and 3/4 locknuts.
3. Connect the radius rod assembly to the front of the gauge wheel lift tube with the installed 1 x 7-1/2 bolts and 1 locknut. Connect the front of the radius rod assembly to the top of the gauge wheel links with 1 x 7-1/2 bolt and 1 locknut. Initially set the radius rod assembly to 21" centers.
4. Install 6-bolt tire/wheel assemblies on the gauge wheel assemblies.

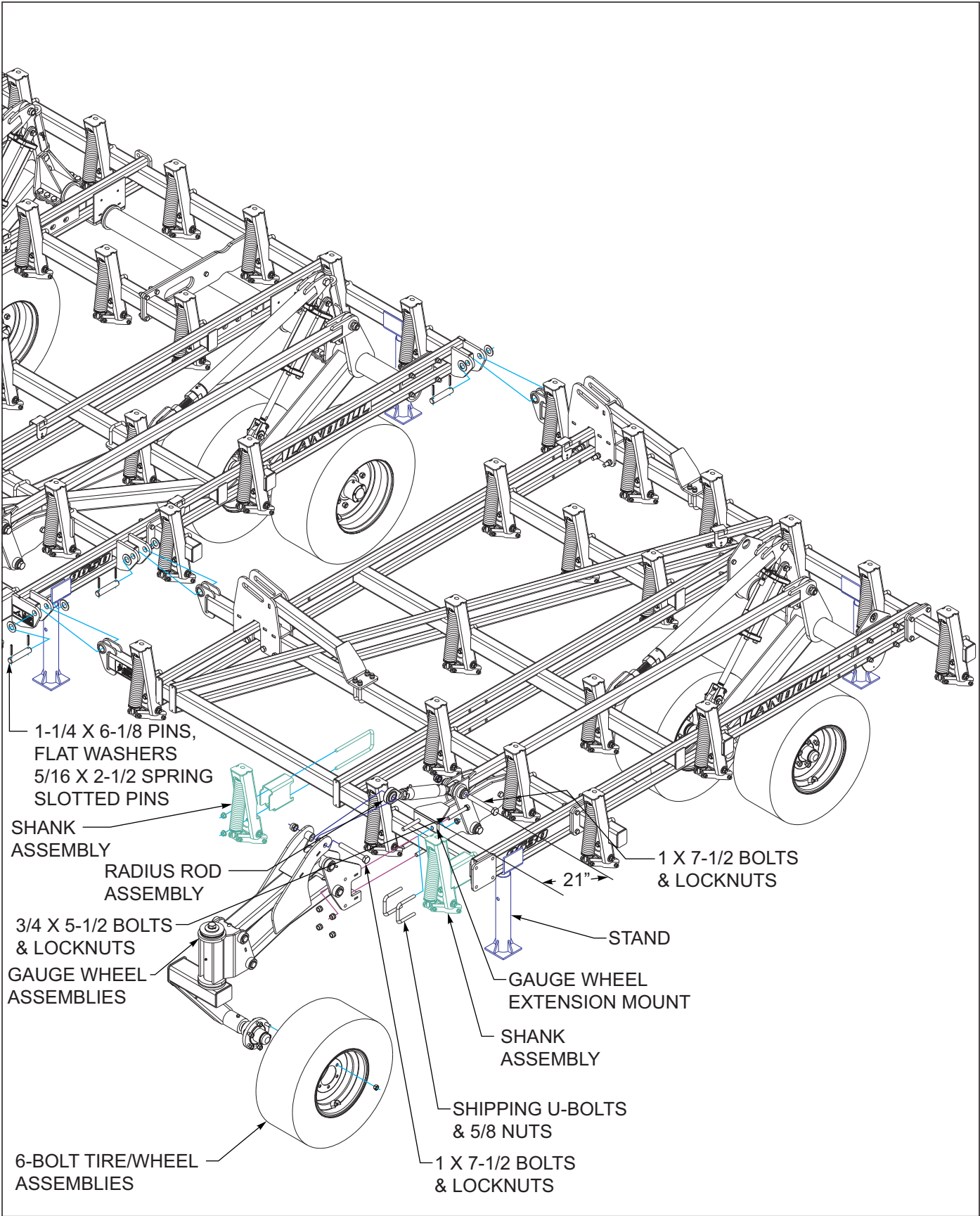

Figure 3-5: Wing Assembly

## Hydraulic Installation

### NOTES

See Figures 3-10 or 3-13 for hydraulic cylinder fittings (factory installed and those installed during setup.)

1. Attach the base end of each 4-1/2 x 30 hydraulic cylinder to the fold cylinder mount on the center frame with clevis and roll pins provided with each cylinder as shown in See Figures 3-6. Position the cylinders so the hydraulic ports point to rear on front cylinders and to front on the rear cylinders.

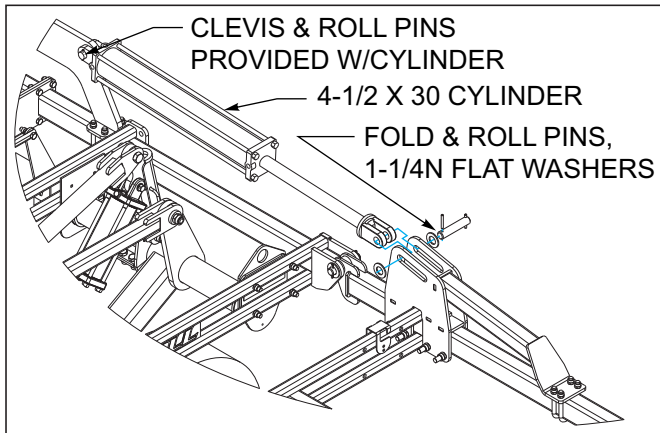

Figure 3-6: Fold Cylinder Installation

### NOTE

**Rod ends of fold cylinders need to be left unassembled until fold hydraulic system is fully charged with oil to prevent machine damage.**

2. Using 1-1/4 x 6-1/8 fold pin, 1-1/4N flat washers, and 5/16 x 2-1/2 spring slotted pins, attach the rod end of the 4-1/2 x 30 cylinders to the slotted mounts on the wing frames See Figures 3-6.



### CAUTION

Restrictors are installed in the rod end of wing fold cylinders to prevent uncontrolled dropping of wings. Removal of these restrictors, or improper installation can result in serious damage to the implement. See Figures 3-13 for proper restrictor fitting identification and location.

3. Install 90 degree regular adapter fittings in both ends of all lift cylinders (4 x 10 and 3-3/4 x 10) See Figures 3-10. Install base fitting in side port, with both fittings pointing upward.

4. Attach hose clamps to the hitch using 3/8-16 x 2-1/2 hex head cap screws and hex lock nuts.
5. Attach hose mounts to lift tower assemblies with 1 x 4 screws and 1 lock nuts.

### NOTE

2 hose mounts used on center section See Figure 3-1 & See Figure 3-10 for placement and orientation.

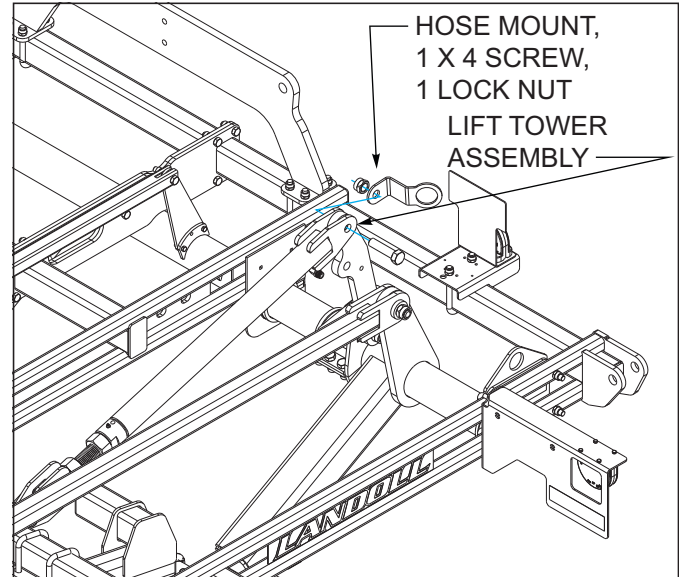

Figure 3-7: Hose Mount Installation

6. Install a 6-1/4" long piece of black trim in the top hole of the lift bearing caps. Outer wing bearing caps do not require trim. Install a 6-1/4" long piece of black trim in the hole of the hose mounts See Figure 3-8. Route lift hydraulic hoses through bearing caps between frame sections See Figure 3-8.

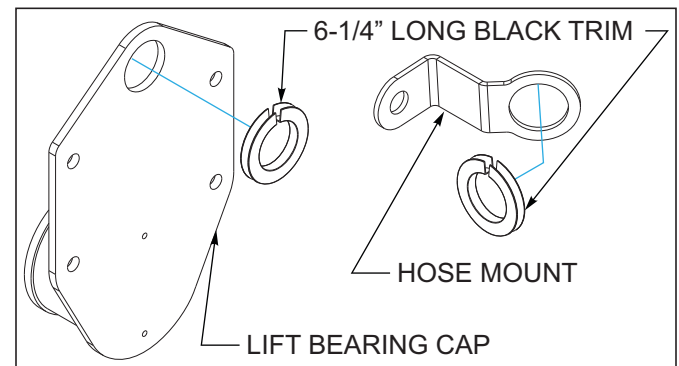

Figure 3-8: Trim Installation



7. Install lift system hoses per **Figure 3-10**. Wrap lift system hoses with blue hose wrap.

**NOTE**

***Use side port for all base end lift cylinder connections.***

8. Install fold system hoses per **Figure 3-13**. Wrap fold system hoses with yellow hose wrap.

9. Attach hose clamps to the center and wing frames **See Figures 3-9** using 3/8 x 2-3/4 hex head cap screws and 3/4 lock nuts.

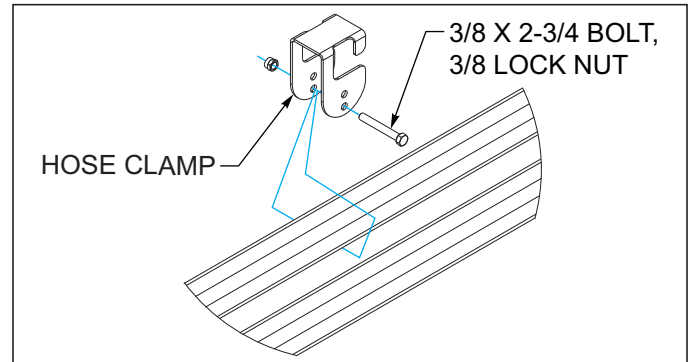

**Figure 3-9: Hose Clamp Installation**

# ASSEMBLY INSTRUCTIONS

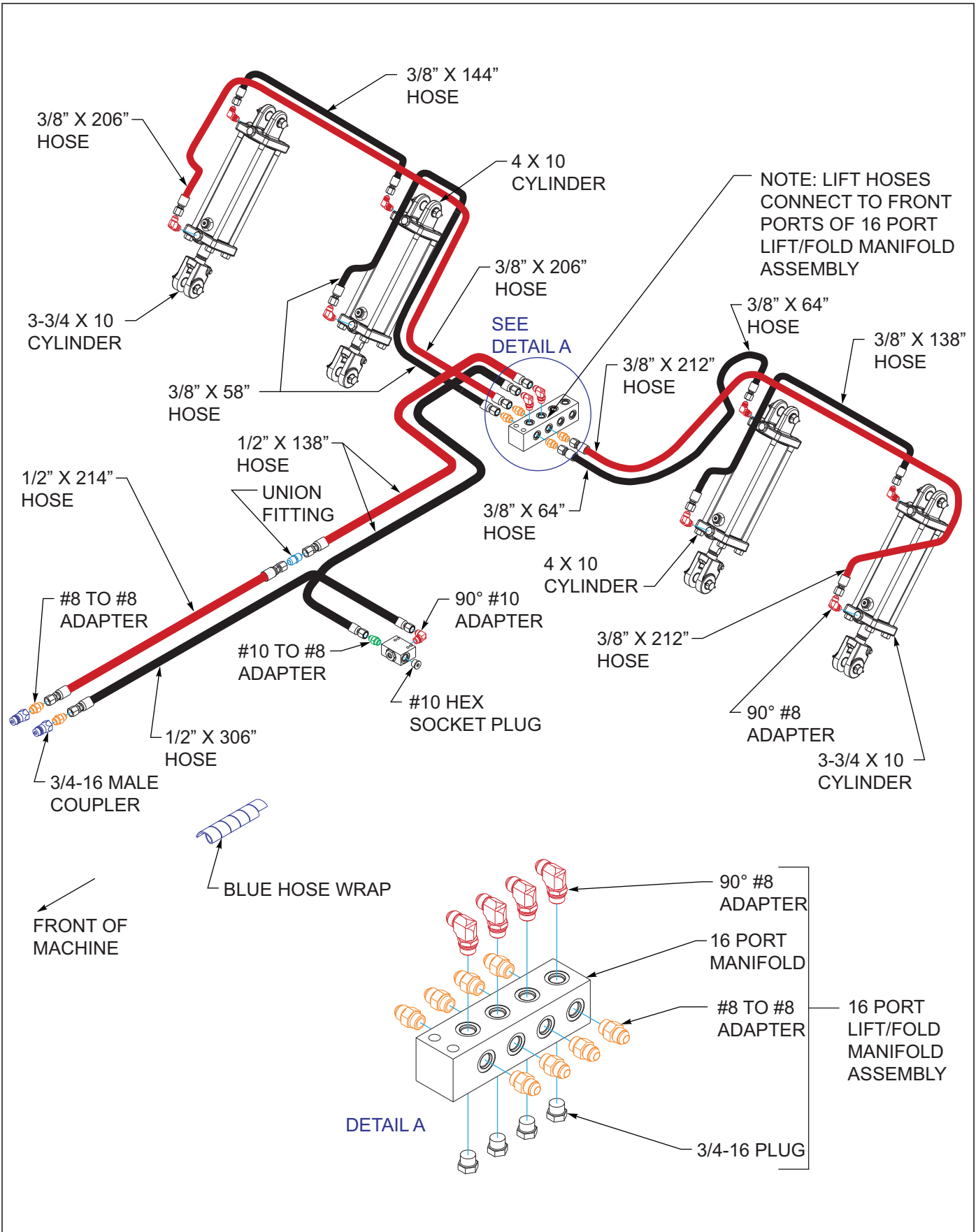

Figure 3-10: Hydraulic Lift Installation 9630FH



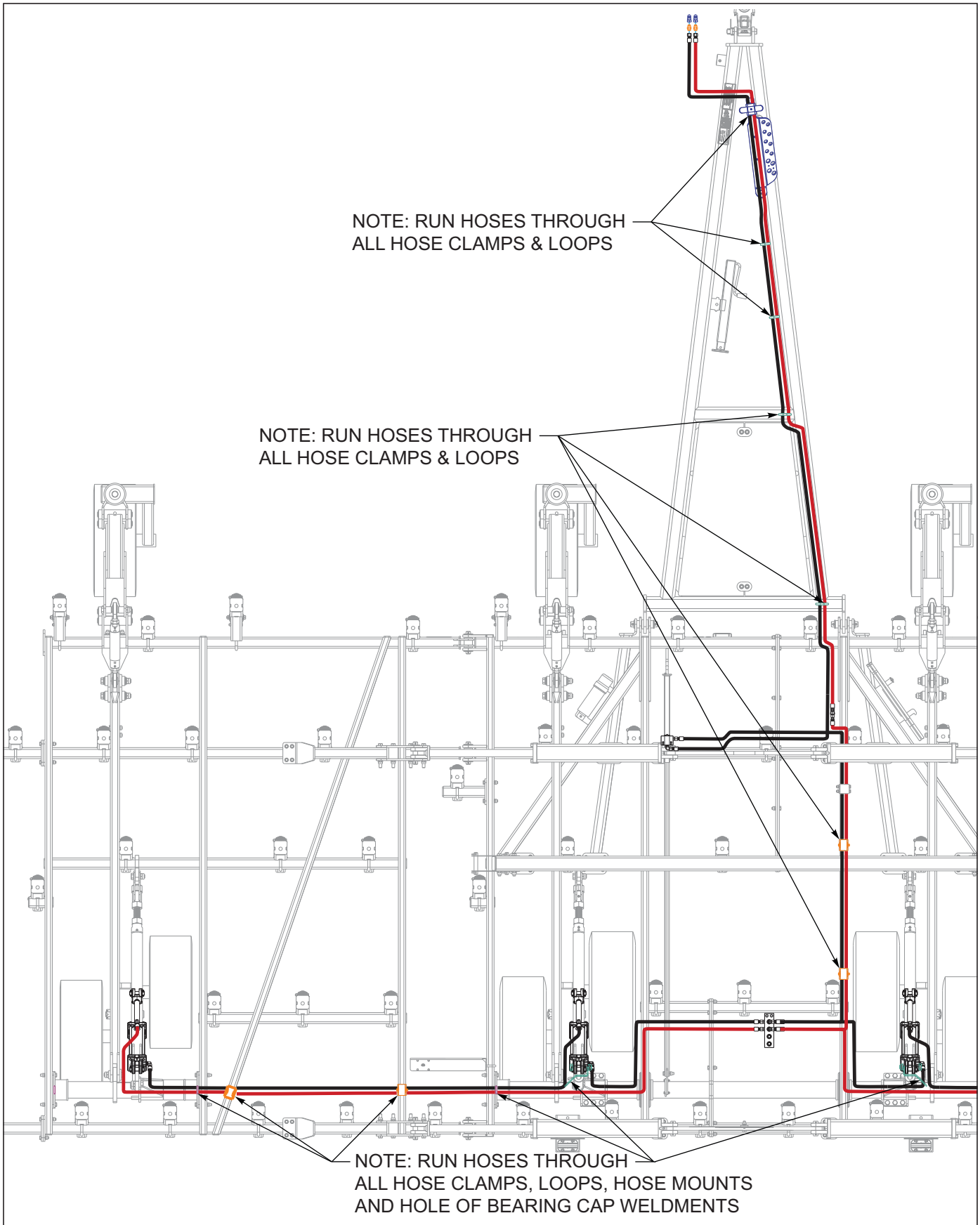

Figure 3-11: Hydraulic Lift Layout 9630FH LH

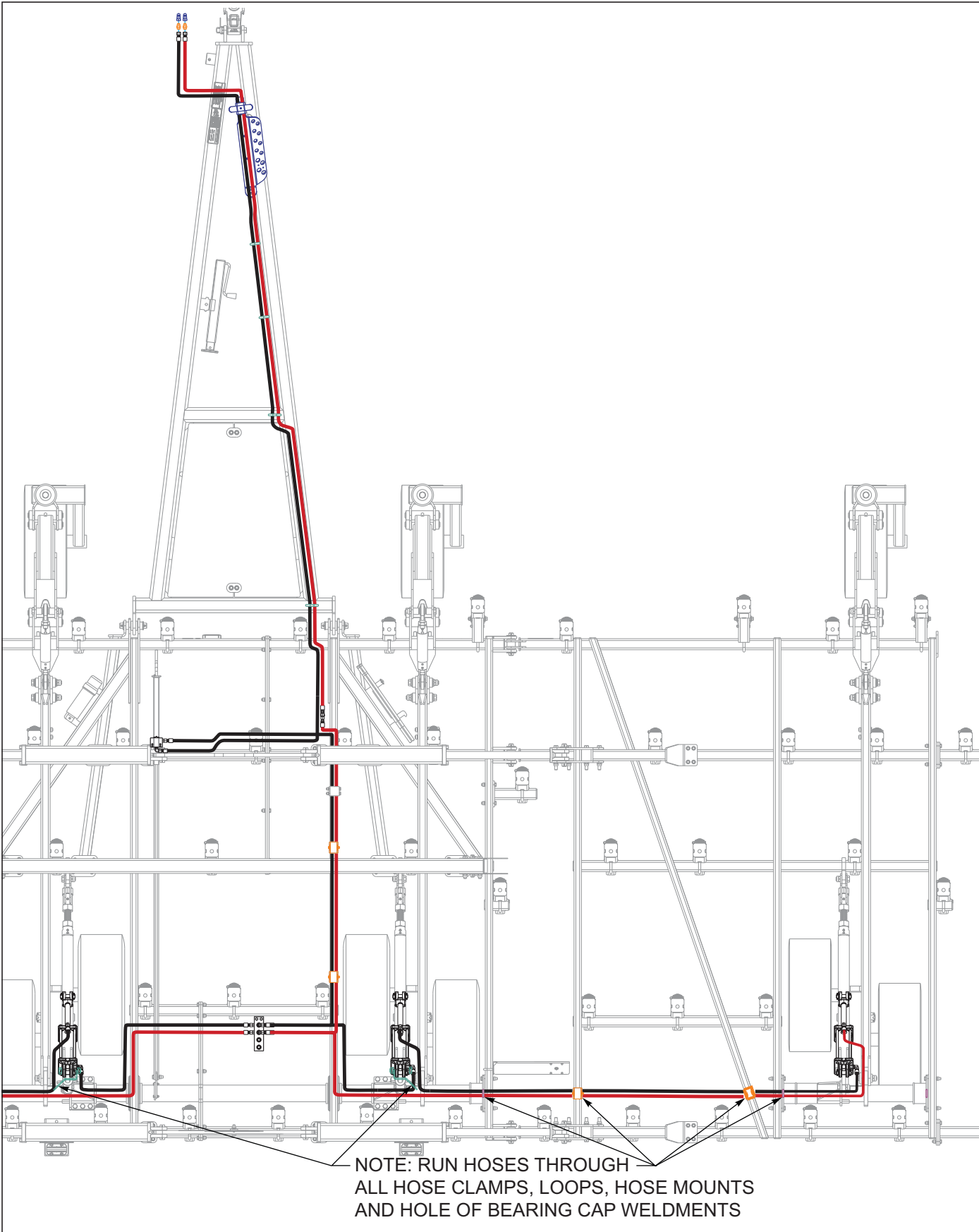

Figure 3-12: Hydraulic Lift Layout 9630FH RH

# ASSEMBLY INSTRUCTIONS

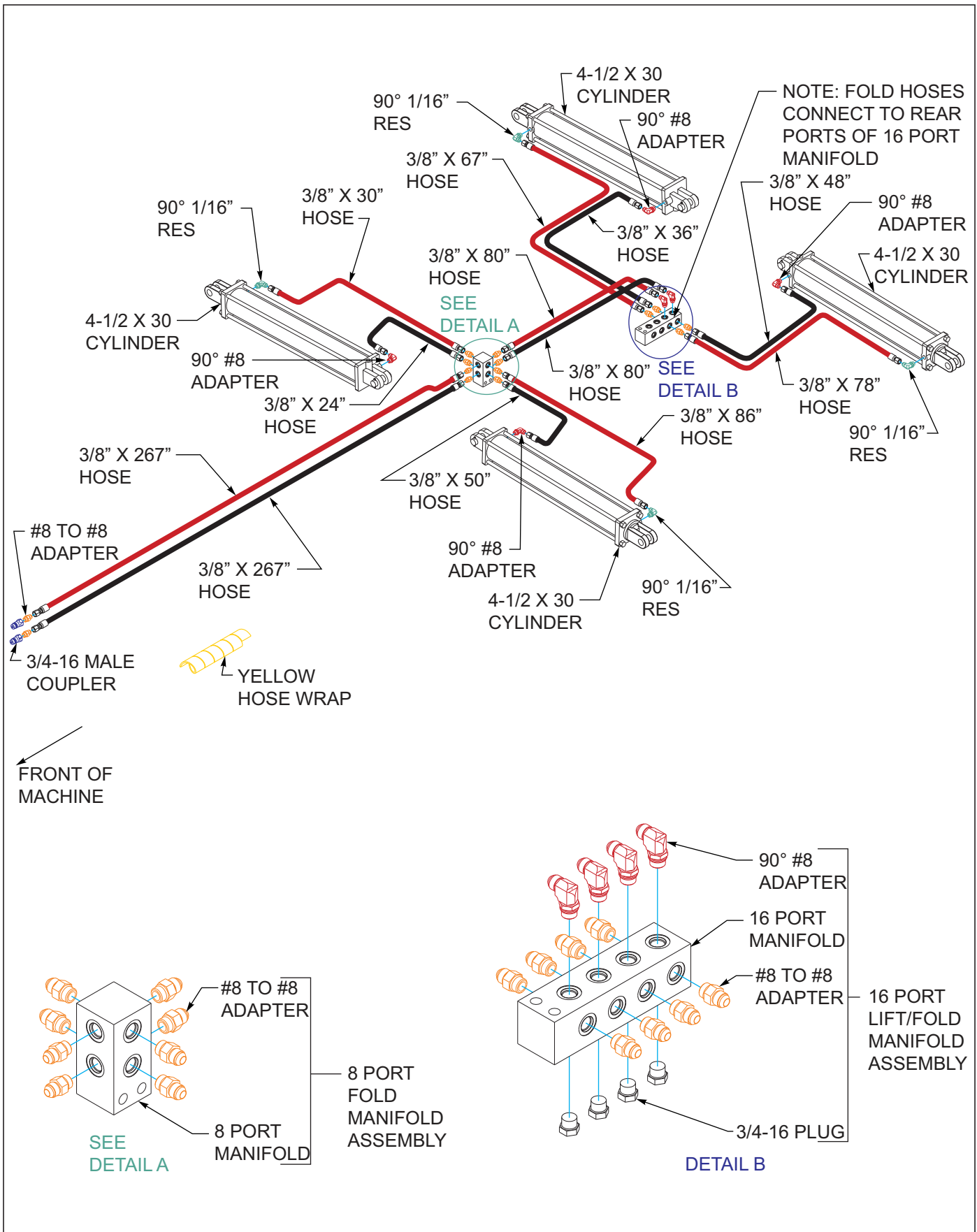

Figure 3-13: Hydraulic Fold Installation 9630FH

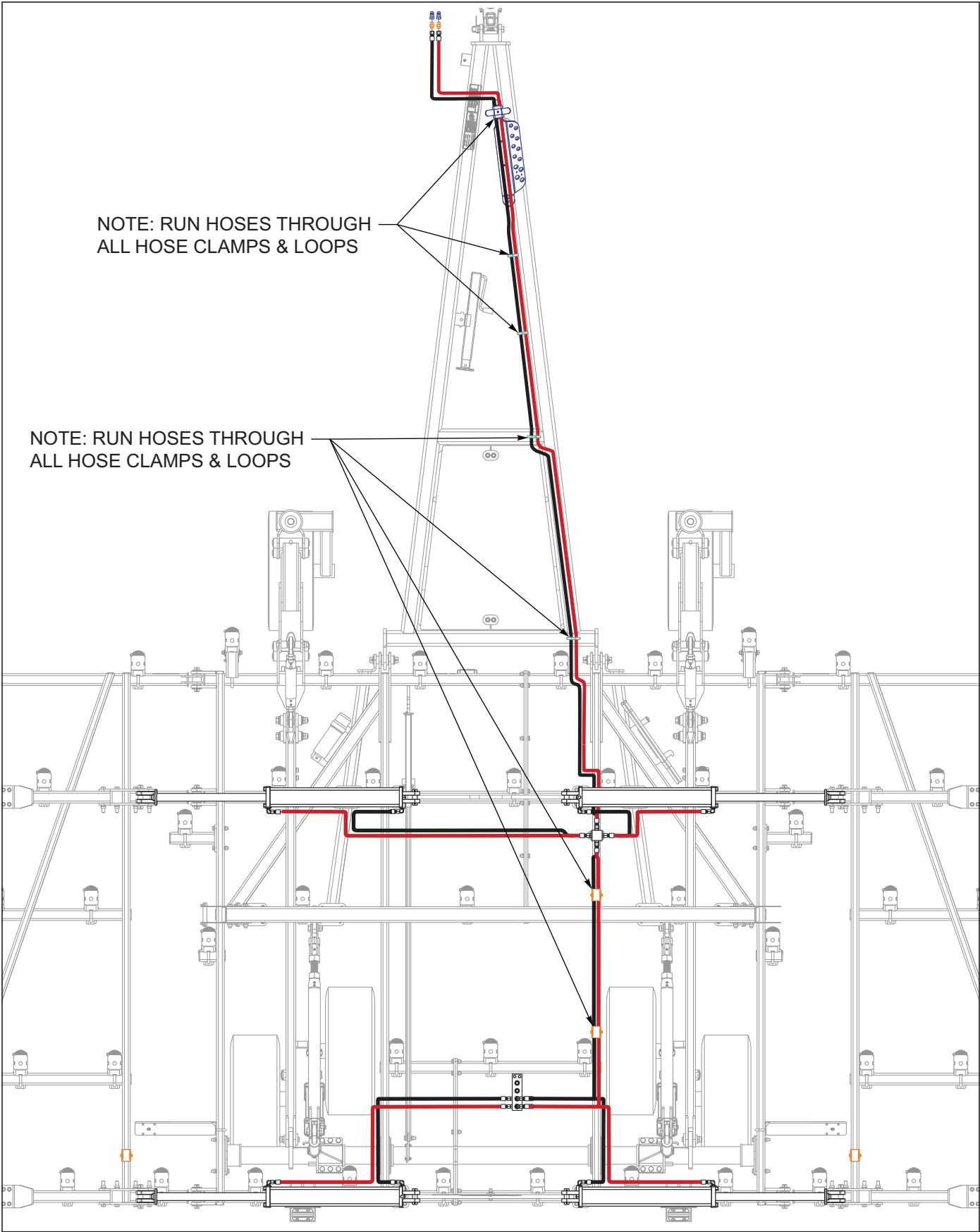

Figure 3-14: Hydraulic Fold Layout 9630FH





7-PIN CONN.	4-PIN TOWER	CIRCUIT	WIRE COLOR
1	D	GROUND	WHITE 
2	-	WORK LAMPS	BLACK 
3	B	LEFT FLASHING & TURN	YELLOW 
4	-	STOP LAMPS	RED 
5	A	RIGHT FLASHING & TURN	GREEN 
6	C	TAIL LAMPS	BROWN 
7	-	SWITCHED POWER (12 V)	BLUE 

MAIN WARNING LIGHT HARNESS - WIRING CHART

	1	2	3	4	5
	2-PIN TOWER	3-PIN TOWER	6-PIN SHROUD	3-PIN TOWER	2-PIN TOWER
 BLACK LEFT TURN			A	C	
 WHITE GROUND	A	A	B	A	A
 BROWN TAIL LIGHT		B	C	B	
 YELLOW LEFT TURN			D		B
 GREEN RIGHT TURN	B		E		
 RED RIGHT TURN		C	F		

REAR WARNING LIGHT HARNESS - WIRING CHART

Figure 3-15: LED Light Harness Wire Designations

### LED Light Installation

1. Attach LH and RH amber light bracket assemblies to center frame using 1/2 x 2-1/8 x 3-1/4 u-bolt and lock nuts [See Figures 3-16](#) and [See Figures 3-17](#) for light bracket placement location.
2. Attach ag flasher control module to bottom of right tail light mount with 1/4 x 1-1/2 bolts and lock nuts.
3. Route the 4 and 6 pin connectors to the front of the light mount.
4. Install the light mount and ag flasher control module to frame assembly with 5/8 x 3-11/16 x 6-3/8 u-bolts and lock nuts.
5. Attach the ag red single LED lamps and reflector assembly to tail light mounts using 1/4 x 1-1/2 bolts and lock nuts.
6. Install the rear warning light harness to the frame. Connect 2 pin and 3 pin ends to each of the warning lights. Connect 6 pin to the ag flasher control module [See Figures 3-15](#) for harness wire designations.
7. Attach front warning harness to frame. Connect 4 pin end to the ag flasher control module.
8. Insure that the harnesses are clear of any moving parts and secure the harnesses with tie straps provided. [See Figures 3-17](#) for light harness routing.
9. Attach the smv mounting bracket to front side of the rear cylinder mount with 5/8 x 2-1/2 bolts and 5/8 lock nuts [See Figures 3-16](#) Detail A.
10. install the Landoll decal to the rear of the cylinder mount rear.
11. Attach the SIS decal mount, SIS 20 mph decal, smv emblem using 1/4 x 1 bolts and lock nuts.

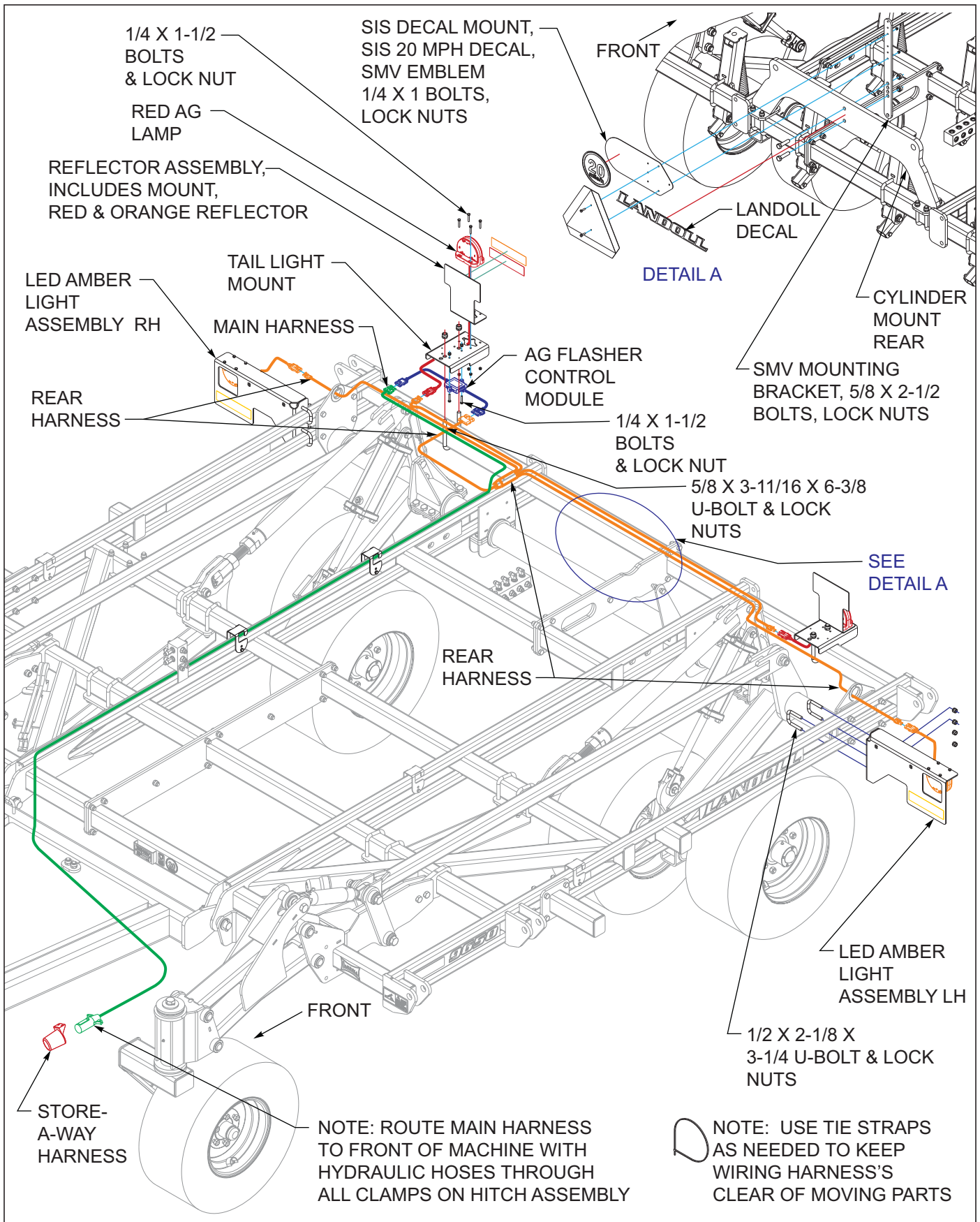

**Figure 3-16: LED Light Installation**

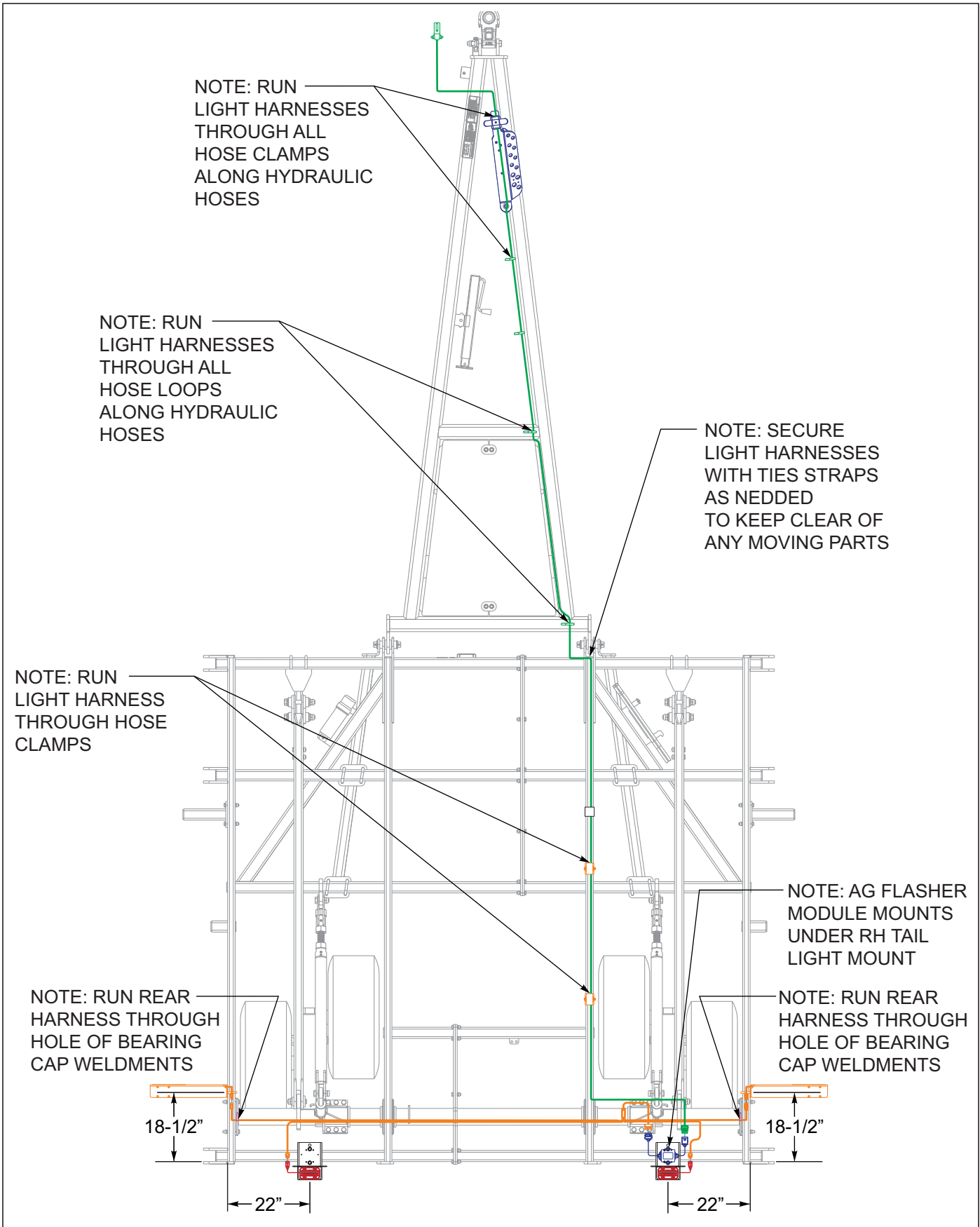

Figure 3-17: LED Light Layout



## Shank Installation

See [Figure 2-2](#) through [2-6](#) for shank placement dimensions. Verify that all shank clamps and extensions are properly installed.

1. Install shanks in clamps See [Figure 3-19](#).
  - a. Spring clamp assembly - Install shank in clamp using 5/8 X 1-3/4 round head square neck screw and flange lock nut provided.
  - b. Install shank clamp, 1/2 x 3-1/4 hex head cap screw, and lock nut across bottom of shank clamp weldment.
  - c. S-tine clamp assembly - Install shank in S-tine spring using 5/8 X 2-1/4 bolt and flange lock nut provided.
2. Install sweep on shank with 7/16 X 1-1/2 plow bolt, washers, and nuts provided. Note that the flat washer is only used in the lower slotted sweep hole.

**NOTE**

Spring shank assemblies with frame extensions (front bar) are mounted reversed for narrower shipment. These shanks must be removed and turned forward for proper operation. See [Figure 2-2](#) through [2-6](#) for proper placement. and See [Figure 3-19](#) for proper u-bolt and shank extension. After shanks have been reversed, verify that springs have been set to the proper tension. Adjust the spring until there is 1/8" gap between the top of the mount and locking jam nut on top of the spring See [Figure 3-18](#) Lock the jam nut against the top of the spring, not the top of the mount.

**NOTE**

Refer to "[Spring Shank](#)" on page 4-9 for proper adjustment and operation of spring shanks.

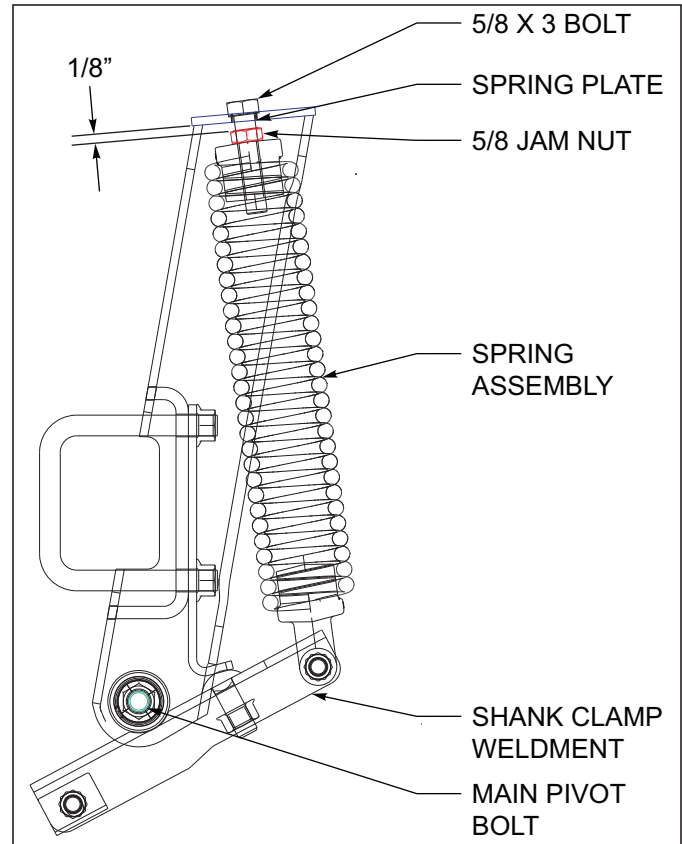

**Figure 3-18: Spring Adjustment**

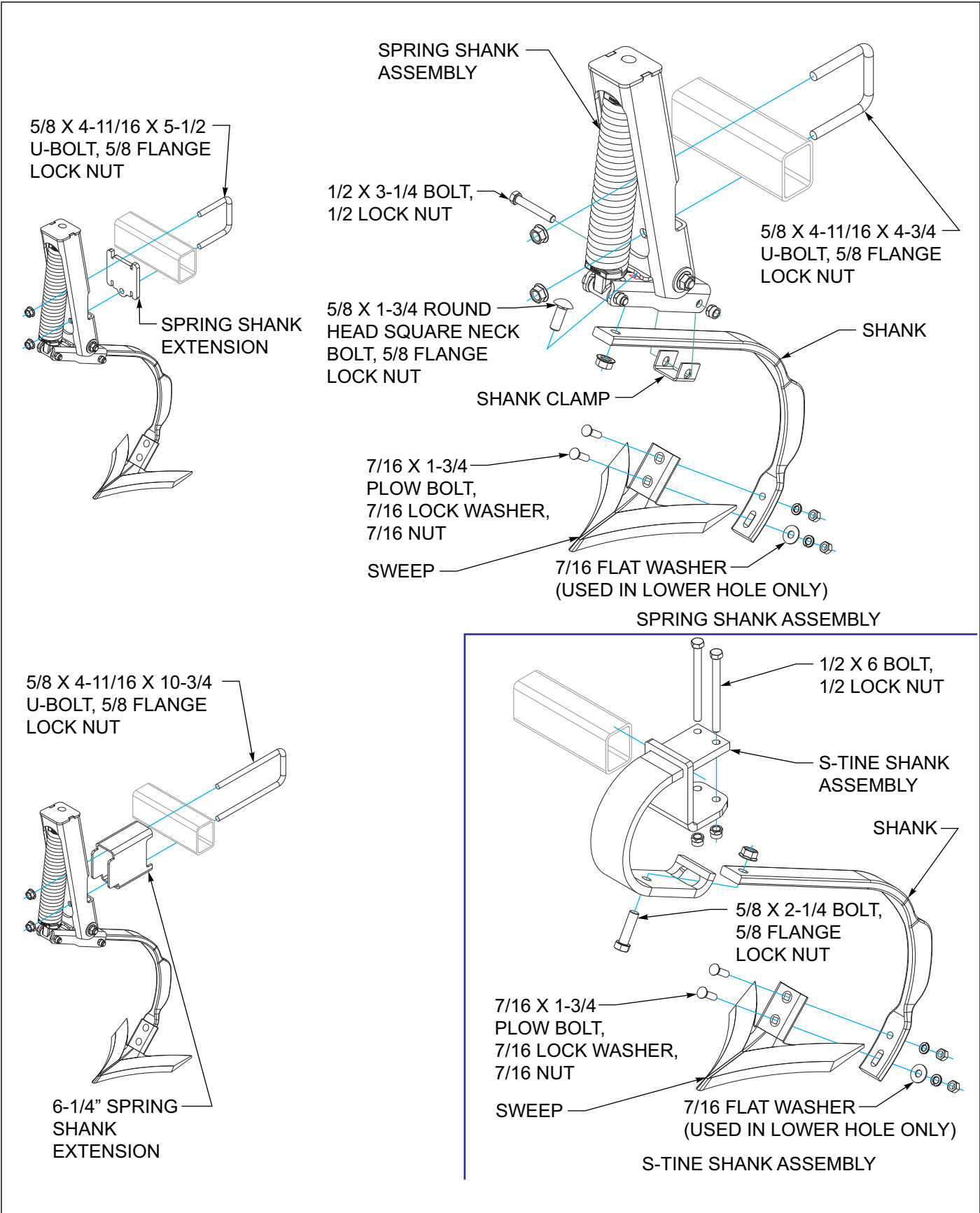

Figure 3-19: Shank Installation

### 4 Row Coil Tine Harrow Installation

Refer to [See Figures 2-7 through 2-18](#) for 4 row coil tine harrow placement.

1. Attach coil tine harrow arms to the rear of the field cultivator [See Figure 3-20](#), according to placement dimensions. Clamp bushings are installed on the top mounting bolts.
2. Assemble the coil tine assemblies to the harrow arms.
3. Front row tines are assembled with the tines above the stop bolts to prevent damage when shipping [See Figure 3-20](#) Detail A. Remove front tine bolts and reinstall, with stop bolts above tines.
4. Refer to the harrow adjustment sections for operation and settings ([See “4 Row Coil Tine Harrow Adjustments” on page 4-16.](#)).



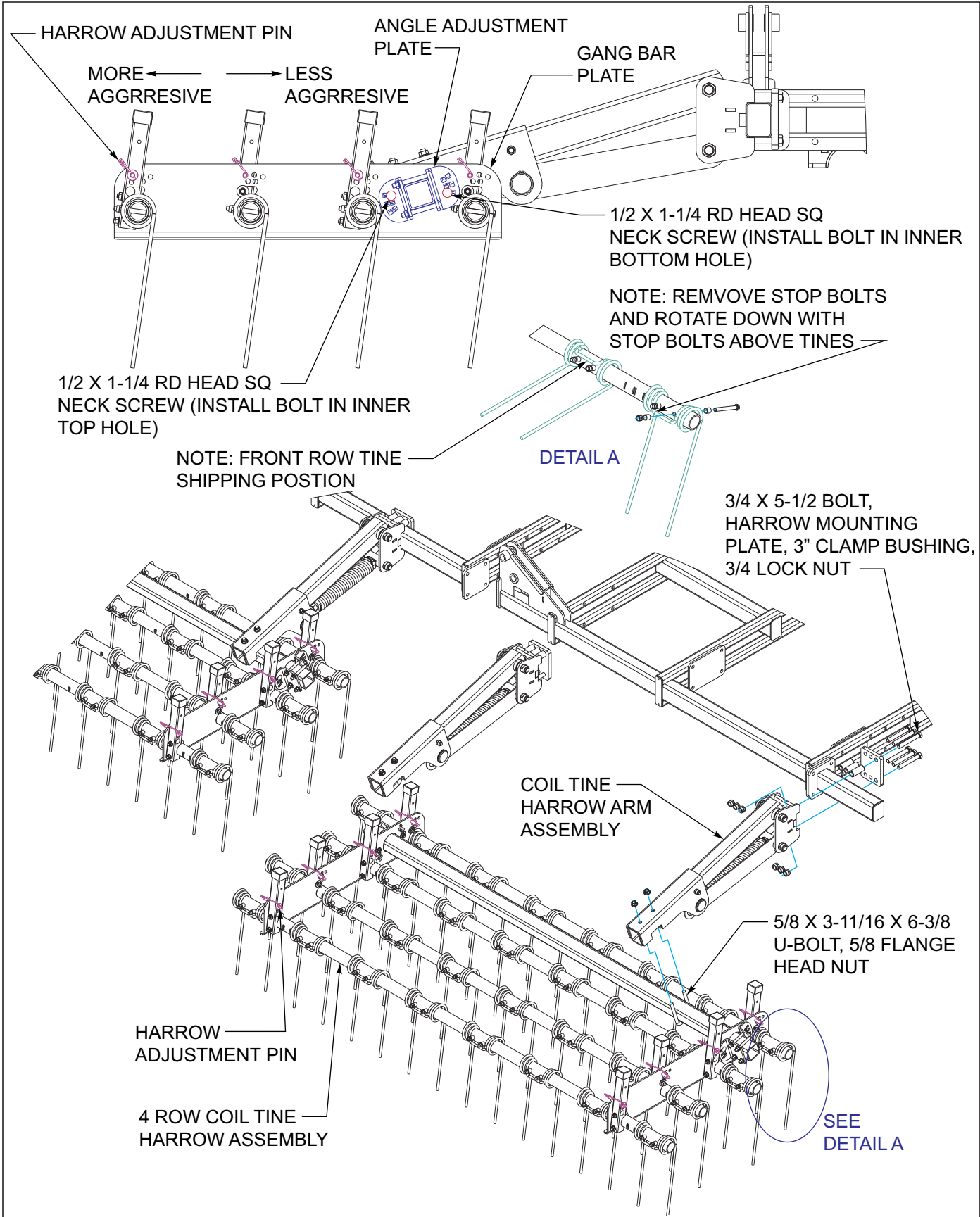

Figure 3-20: 4 Row Coil Tine Harrow Installation

### 3 Row Coil Tine and Reel Harrow Installation

See [Figures 2-19](#) through [2-30](#) for 3 Row Coil Tine Harrow placement dimensions.

1. Attach the tine/reel arm assemblies to the rear tube of the center and wing frames using harrow mounting plates, 3/4 x 5-1/2 bolts, clamp bushings and 3/4 lock nuts [See Figures 3-21](#). Clamp bushings are installed on the top mounting bolts.
2. Attach the harrow tine assemblies in correct location with 5/8 u-bolts and 5/8 flange lock nuts.
3. Attach reel assemblies to the reel arm assemblies using 5/8 x 3-11/16 x 4-5/8 u-bolts and 5/8 lock nuts.
4. Refer to the “3 Row Coil Tine & Reel Adjustments” in Operation and Maintenance section for coil tine adjustments ([See Figure 4-15](#)).

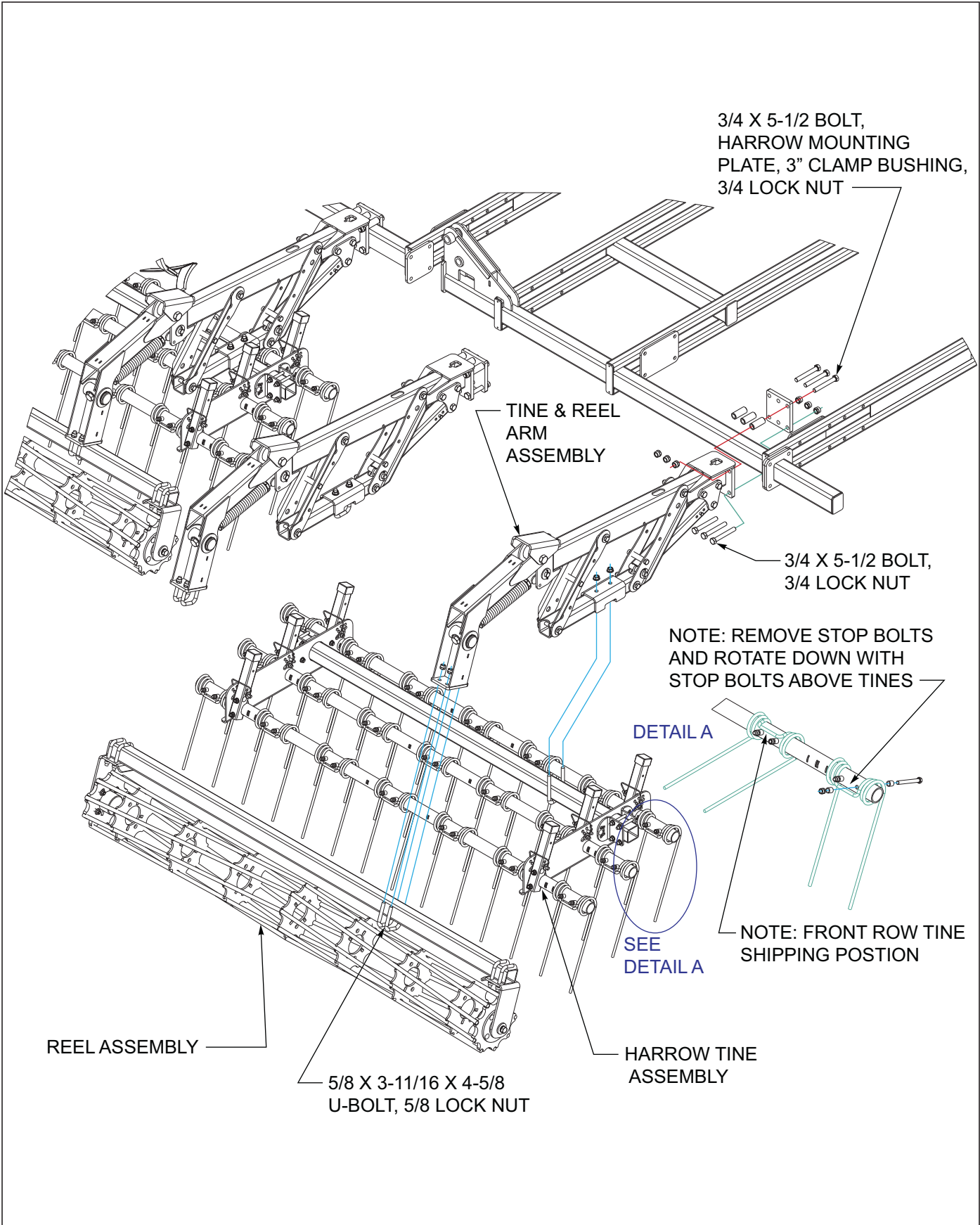

Figure 3-21: 3 Row Coil Tine and Reel Harrow Installation

### 5 Row Spike Harrow Installation

*See Figures 2-15 through 2-20* for 5 Row Spike Harrow placement dimensions.

1. Attach 5 row spike harrow arm assemblies, harrow arm clamp plate and spike harrow arm clamp to rear frame using 3/4-10 x 9 hex bolts and 3/4 lock nuts  
*See Figure 3-22.*

#### **NOTE**

*Location of bar clamps with tabs, and position harrow arm assemblies in the correct locations.*

2. Attach pull chain bracket to spike harrow arm clamp using 3/4-10 x 5 hex bolts and 3/4 lock nuts.
3. Refer to Note: spike bar alignment *See Figure 3-22* for proper alignment of spike bar assemblies. Be sure they are aligned properly on both right and left side of each section.

4. Attach spike bars to 5 row spike harrow arm assemblies per placement drawings using bar clamp plates, spike bar clamp plates, harrow bar mounts, 1/2-13 x 3 hex head cap screws, or harrow bar mounts w/ tabs, 1/2-13 x 1-1/4 hex bolts, and 1/2 lock nuts.
5. Refer to the “5 Row Spike Harrow Adjustments” in Operation and Maintenance section for spike bar alignment *See Figures 4-14.*

#### **NOTE**

*See Figures 2-15 through 2-20* for 5 Row Spike Harrow placement dimensions of spike harrow arms, harrow bar mounts, and usage of bar clamps or harrow bar mounts w/ tabs.

NOTE: SPIKE BAR ALIGNMENT  
RIGHT SIDE SHOWN

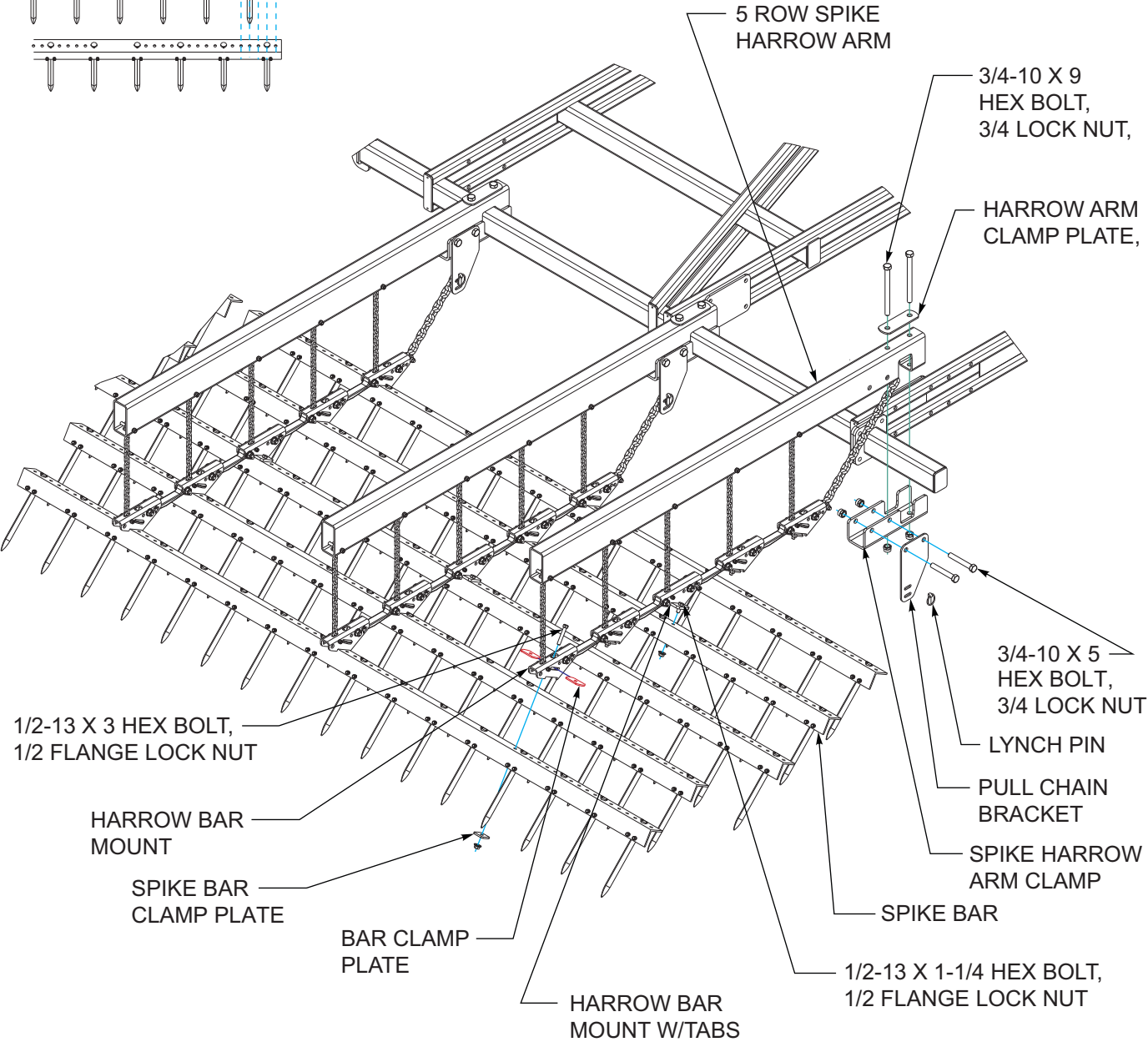
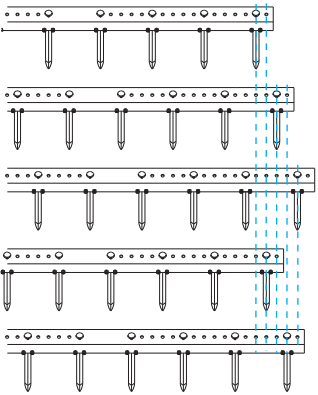

Figure 3-22: 5 Row Spike Harrow Assembly

## 3 Row Spike and Reel Harrow Installation

See Figures 2-43 - 2-54 for 3 Row Spike and Reel Harrow or See Figures 2-55 - 2-66 3RSD & flat reel for placement dimensions in “Standard Specification” section.

1. Attach the 3 RSD w/spring and 3 RSD w/o spring arm assemblies to the rear tube of the center and wing frames using harrow mounting plates, 3/4 x 5-1/2 bolts, clamp bushings and 3/4 lock hex nut See Figure 3-24.
2. Harrow arms 3 RSD w/o spring are used on the middle harrow arm on the wings.

### NOTE

**Location of harrow bar mount with tabs, and position harrow arm assemblies in the correct locations.**

3. Refer to Note: spike bar alignment See Figures 3-24 for proper alignment of spike bar assemblies. Be sure they are aligned properly on both right and left side of each section.
4. Attach spike bars to 3 RSD spike harrow arm assemblies per placement drawings using harrow bar mounts, bar clamp plates 1/2 x 3 bolts, or harrow bar mounts w/ tabs, 1/2 x 1-1/4 bolts, and hex lock nuts.
5. See spring assembly adjustment for initial setting in “Operating Section”.
6. Attach reel assembly or flat reel assembly to 3 RSD arm assemblies using 5/8 u-bolts and 5/8 hex lock nuts.

7. Attach flat bar reels with angled blades as shown See Figure 3-23.

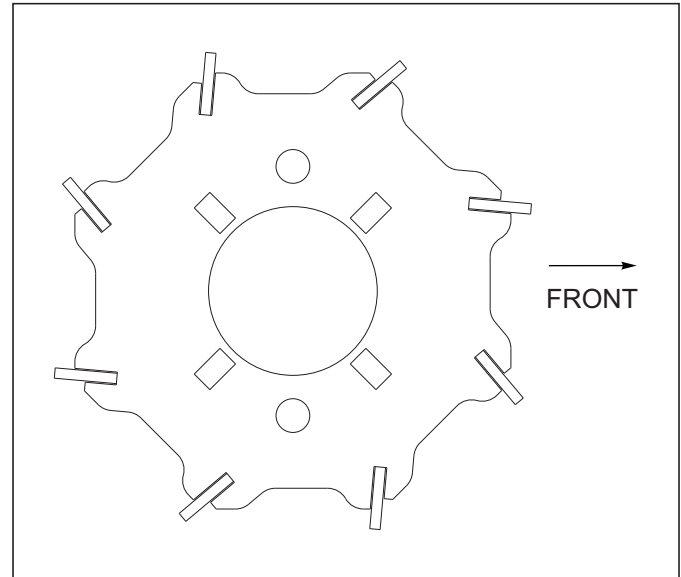

Figure 3-23: Flat Reel

8. See Figures 2-21 - 2-26 for 3 Row Spike and Reel Harrow or See Figures 2-27 - 2-32 3RSD & flat reel placement dimensions of spike harrow arms, spike bars, and usage of bar clamps or bar clamps w/ tabs.
9. Refer to “3 Row Spike and Reel Adjustments” on page 4-23 in “Operation and Maintenance” section for spike angle and spring adjustments.

NOTE: SPIKE BAR ALIGNMENT  
RIGHT SIDE SHOWN

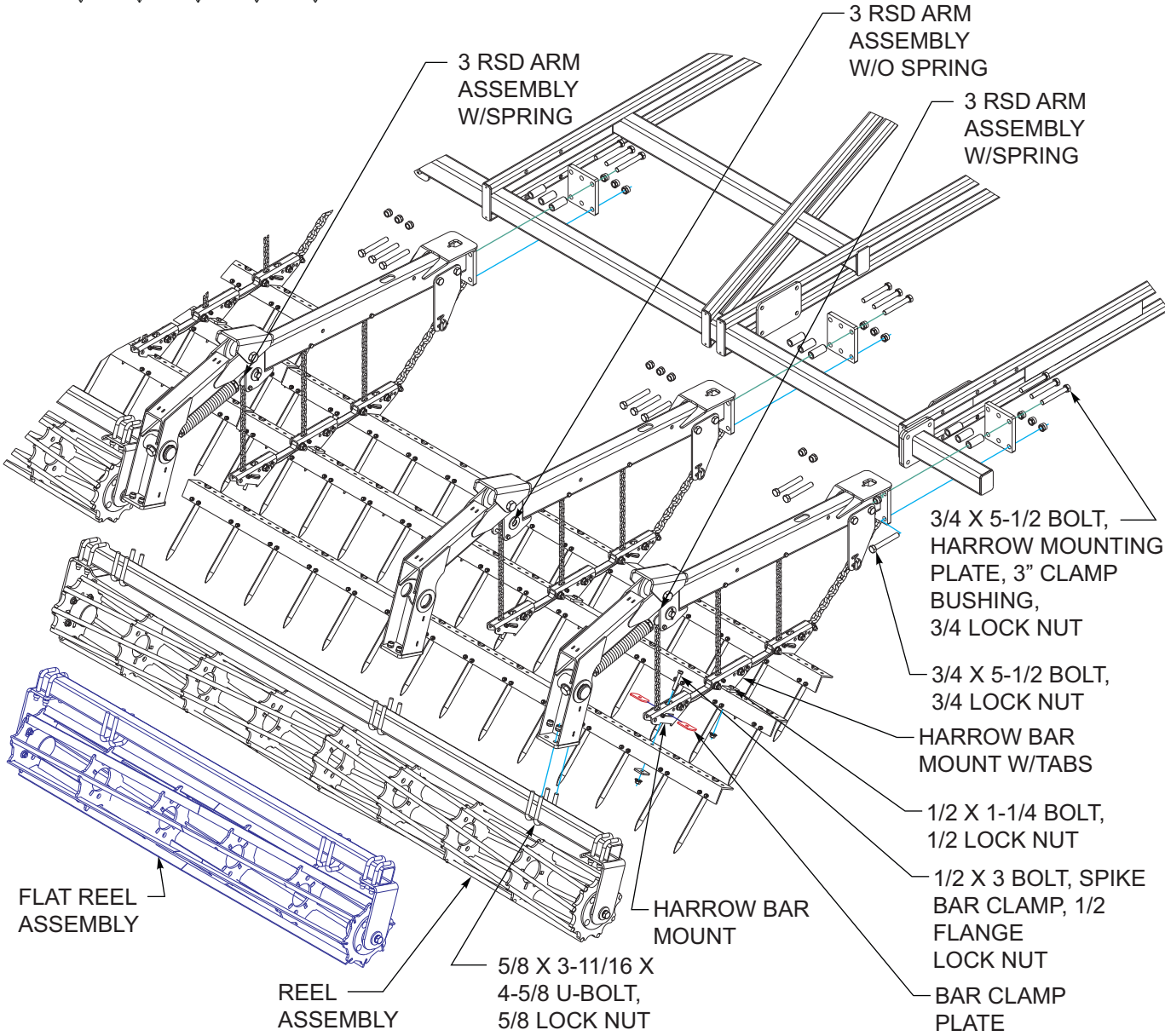
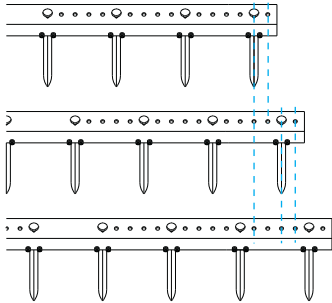

Figure 3-24: 3 Row Spike Harrow and Reel Installation

### Rear Tow Hitch (Option)

1. Unfold and lower the field cultivator to the ground.
2. Remove the 3/4-10 x 8-1/2 hex bolts and 3/4-10 lock nuts from weight hitch plates *See Figures 3-25*.
3. Install the new additional weight hitch plate on top of the existing plates and secure with 3/4-10 x 10-1/2 hex bolts and 3/4-10 lock nuts.
4. Remove the cylinder pins from the rear fold cylinder mount.
5. Remove the rear fold bracket by removing the 5/8-11 x 3-11/16 x 5-1/2 u-bolts and 5/8-11 lock nuts.
6. Slide the rear tow hitch assembly into place over the top of the field cultivator frame, and attach the rear tow hitch assembly to the rear bar of the cultivator with 5/8-11 x 4-11/16 x 4-3/4 u-bolts and 5/8-11 lock nuts. Leave the u-bolts loose until all other bolts have been installed.
7. Attach the front of the tow hitch assembly to the cultivator frame cross tubes using 5/8-11 x 3-11/16 x 5-1/2 u-bolts and 5/8-11 lock nut.
8. Center the rear tow hitch assembly on center frame *See Figures 3-26*, tighten all u-bolts to secure hitch.
9. Reinstall the rear cylinder fold mount and re-pin the rear fold cylinders.
10. Route the tandem light harness connector across the rear frame bar to the right rear tail light. Unplug the existing four-pin main wiring harness from the lighting module. Connect the rear tow hitch harness between the lighting module and the main wiring harness *See Figures 3-25* and *See Figures 3-26* for proper hose and light harness routing.
11. Route the rear tow hitch hydraulic hoses along with the other hydraulic hoses along the right side of the center frame to the front of the hitch.
12. Secure the hoses & wiring to the frame using tie-straps and hose clamps.



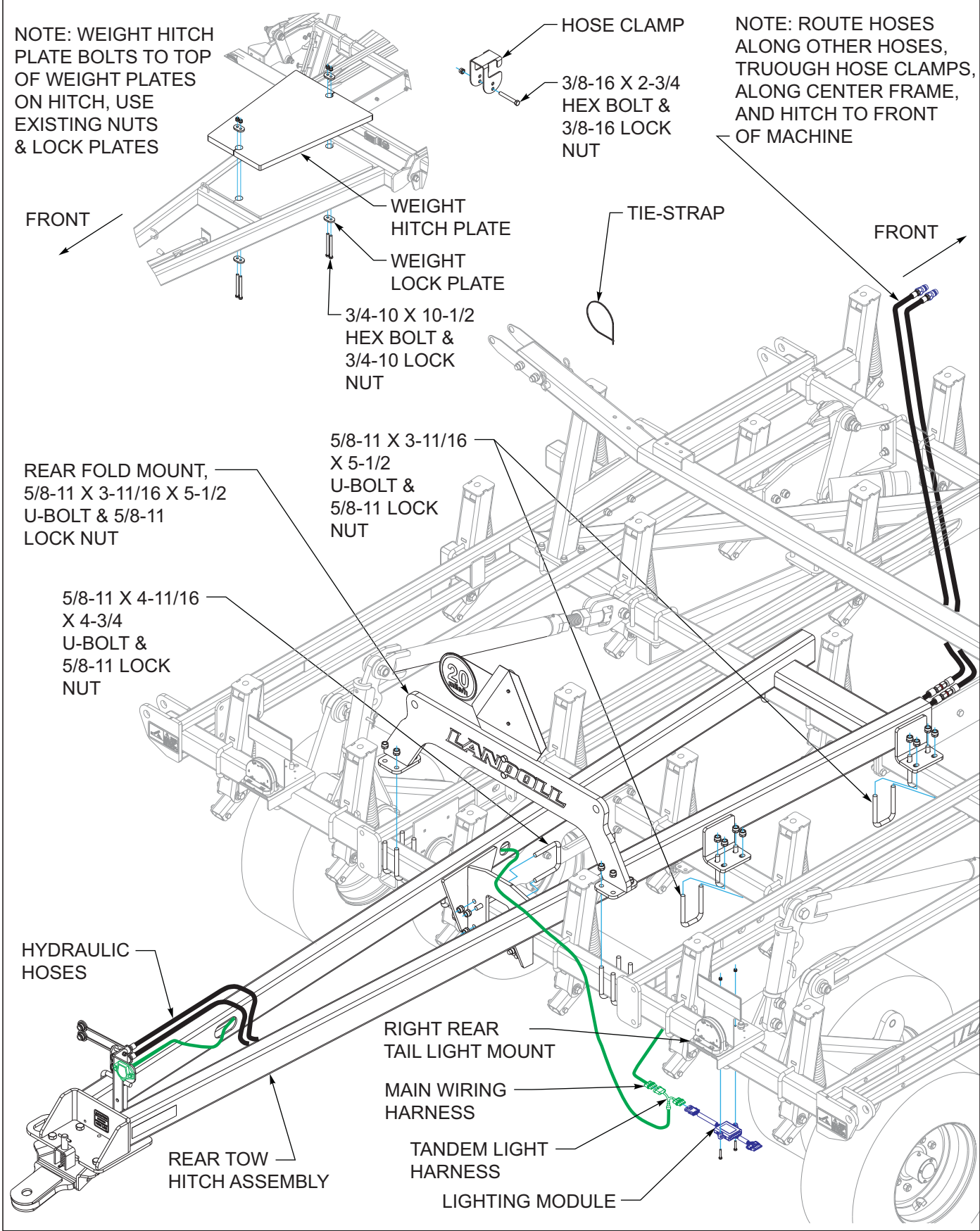

Figure 3-25: Rear Tow Hitch Installation

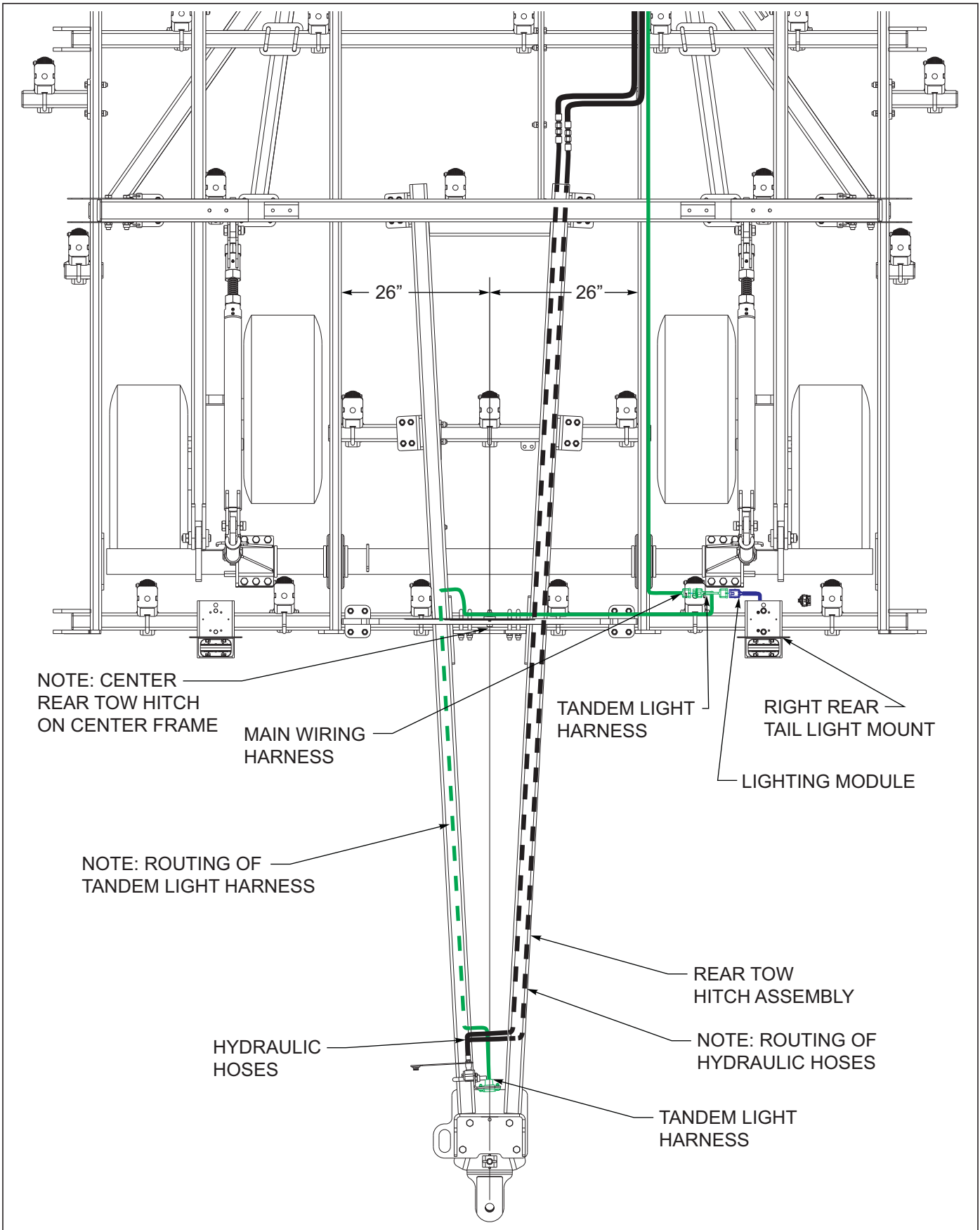

Figure 3-26: Rear Tow Hitch Layout

## Operation and Maintenance

---



### DANGER

Never allow anyone to ride on the 9630FH Field Cultivator at any time. Allowing a person to ride on the machine can inflict serious personal injury or death to that person.



### DANGER

Stand clear of wings while folding and unfolding. all hydraulically elevated equipment must have cylinder lockouts installed or be lowered to the ground, when servicing or when equipment is idle. Failure to take preventive measures against accidental lowering can result in serious personal injury.



### DANGER

Always lock the tractor drawbar in the center position when transporting the unit. Failure to do so can result in serious injury or death and cause damage to the equipment.



### DANGER

When transporting the unit, place cylinder lockouts in the transport lock position after fully extending the cylinders. Insert the lockout pins to secure the cylinder lockouts. Failure to lockout the cylinders can cause the unit to settle during transport, which can result in serious injury or death and cause damage to the equipment.



### CAUTION

When transporting farm implements on public roads, it is the responsibility of the operator to abide by state and local laws concerning wide loads, speed, safety emblems and safety lighting equipment. Drive at safe speeds. Particularly when rounding corners, crossing rough ground or driving on hillsides, to prevent tipping the tractor.

## Hydraulic Lift System

The Field Cultivator is equipped with a rephasing hydraulic lift system to raise and lower the unit in the field.



Figure 4-1: Hydraulic Leak Detection



### WARNING

Escaping hydraulic fluid can cause serious personnel injury. Relieve system pressure before repairing, adjusting, or disconnecting. Wear proper hand and eye protection when searching for leaks. Use cardboard instead of hands [See Figure 4-1](#). Keep all components (cylinders, hoses, fittings, etc.) in good repair.

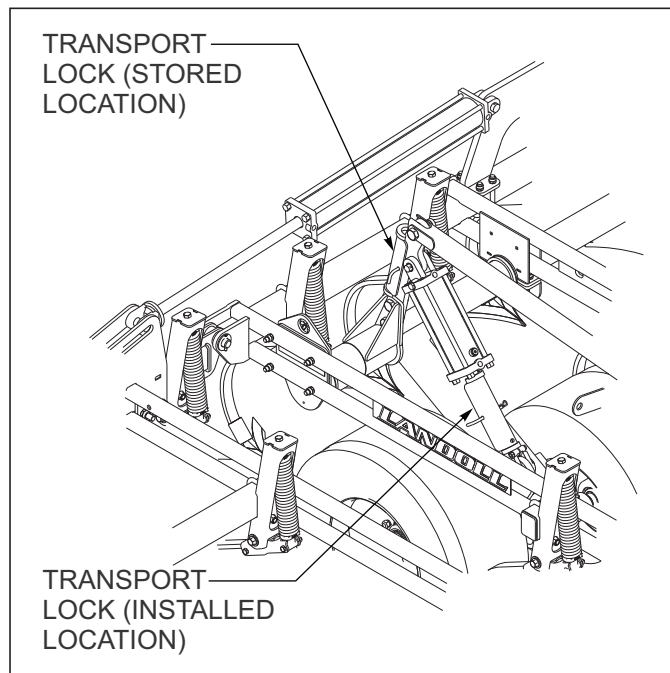

Figure 4-2: Transport Lock Locations

1. The rephasing hydraulic lift system contains smaller wing frame cylinders plumbed in series with larger center frame cylinders. It is important that the cylinders be connected in the proper series for the lift system to operate correctly. When the cylinders are fully extended and held in this position, oil is able to flow through the cylinders (or rephase) and allow the cylinders to operate in sync. This also allows the system to purge any air that may enter the system without having to loosen or crack hydraulic lines.
2. The hydraulic system is not filled with oil and should be purged of air before transporting and field operations. Carefully hitch the Field Cultivator to the tractor and connect the hydraulic lift hoses. Check to make sure the tractor hydraulic reservoir is full of the manufacturer's recommended oil. Slowly raise the machine, and continue to hold the hydraulic lever until all lift cylinders are fully extended. With all cylinders fully extended remove the transport locks [See Figure 4-2](#) Lower and raise the unit to verify that all cylinders are working simultaneously throughout the stroke. If the cylinders are not working evenly or together, fully extend the lift cylinders and continue to hold the lever to purge any remaining air. Do not loosen any hoses or fittings. Recheck tractor reservoir to make sure it is within operating limits.
3. Always fully extend the cylinders and hold the lever to ensure the cylinders are rephased before starting any field operation. This will keep all cylinders in time and frame sections level when operating.
4. Servicing – Before servicing any hydraulic component, lower the implement to the ground and relieve all system pressure. If a hydraulic component is disconnected, repaired, or replaced, it will be necessary to purge the system of air before operation.

### NOTE

*If performing service or repair work, lower the machine down to the ground and relieve hydraulic pressure.*



## Hydraulic Fold System

The Field Cultivator is equipped with a hydraulic fold system to raise and lower the wing frames for narrow transport.

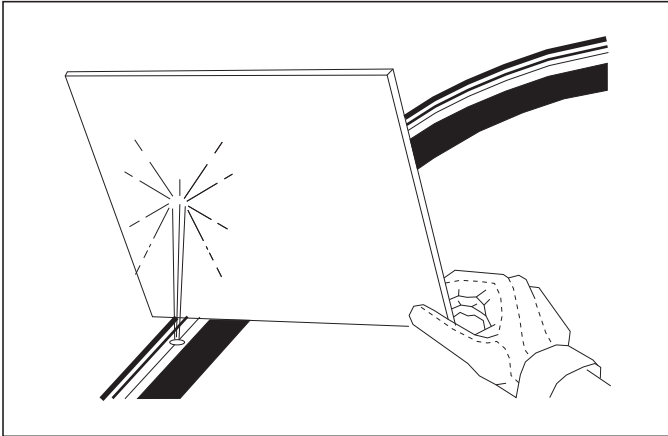

Figure 4-3: Hydraulic Leak Detection



### WARNING

Escaping hydraulic fluid can cause serious personnel injury. Relieve system pressure before repairing, adjusting, or disconnecting. Wear proper hand and eye protection when searching for leaks. Use cardboard instead of hands [See Figure 4-3](#). Keep all components (cylinders, hoses, fittings, etc.) in good repair.

1. Be sure the fold system is fully charged with hydraulic oil before attempting to fold/unfold the unit. Air in the system can allow uncontrolled dropping of the wing frames causing serious personal injury or machine damage. The system needs to be charged with oil initially and any time the system opened for repair such as cylinder, hose, or fitting replacement/repair.
2. To charge the system, pin the cultivator hitch to the tractor, raise the implement jack. Check the tractor hydraulic fluid level to make sure it is full of the manufacturer's recommended hydraulic fluid. Connect the hydraulic fold and lift hoses to the tractor, unpin the end(s) of the fold cylinders, and position them so they can extend and retract without contacting any frames or other parts. Fully extend the lift cylinders and raise the implement. Extend and retract the fold cylinders several times. The fold cylinder rod travel should be smooth and positive when all air has been purged from the system. Due to large amounts of hydraulic oil required, recheck the tractor fluid level to make sure it is within proper operating limits. Reconnect the fold cylinder pins the wings.
3. The Field Cultivator is equipped with a hydraulic fold system to raise and lower the wing frames for narrow transport.
4. The Field Cultivator is equipped with a hydraulic fold system to raise and lower the wing frames for narrow transport.
5. The hydraulic fold system is equipped with restrictors in the cylinders to prevent uncontrolled falling of wing frames when folding/unfolding. Removal or improper assembly of these restrictors can cause the machine to fold improperly and result in serious machine damage.
6. To fold/unfold the Field Cultivator, find a level area large enough to accommodate the machine when it is fully unfolded. The tractor should be stopped and not moving with the implement fully raised. Remove the wing transport lock pins from the mounts and install them in the storage locations [See Figure 4-4](#).  
***Failure to remove the wing lock pins when unfolding will result in serious damage to the implement. Be sure other people and pets are a safe distance away.***
7. Slowly engage the tractor lever and fold/unfold the wing frames. When the wings are unfolded, continue holding the tractor lever to fully extend all fold cylinders. This will allow the wings to fully flex in the field. When the unit is fully folded, remove the wing transport lock pins from the storage location and install in the mounts provided on each side of the machine [See Figure 4-4](#).
8. Maintenance – Regularly check all hydraulic components. Check for hoses that may have become worn or pinched. Look for cylinders, valves, hoses, or fittings that may be leaking hydraulic fluid. Replace or repair any leaking or defective components immediately. Unfold, lower the unit to the ground, and relieve hydraulic pressure before attempting to service any hydraulic component.
9. Storage - For extended periods of non use, it is best to store the Field Cultivator inside if possible. If the unit must be stored outside for extended periods, is best to apply a light coating of oil or grease to exposed cylinder rods to prevent them from rusting. If the unit is stored in the folded position, make sure the wing transport lock pins are installed to prevent wing frames settling [See Figure 4-4](#).

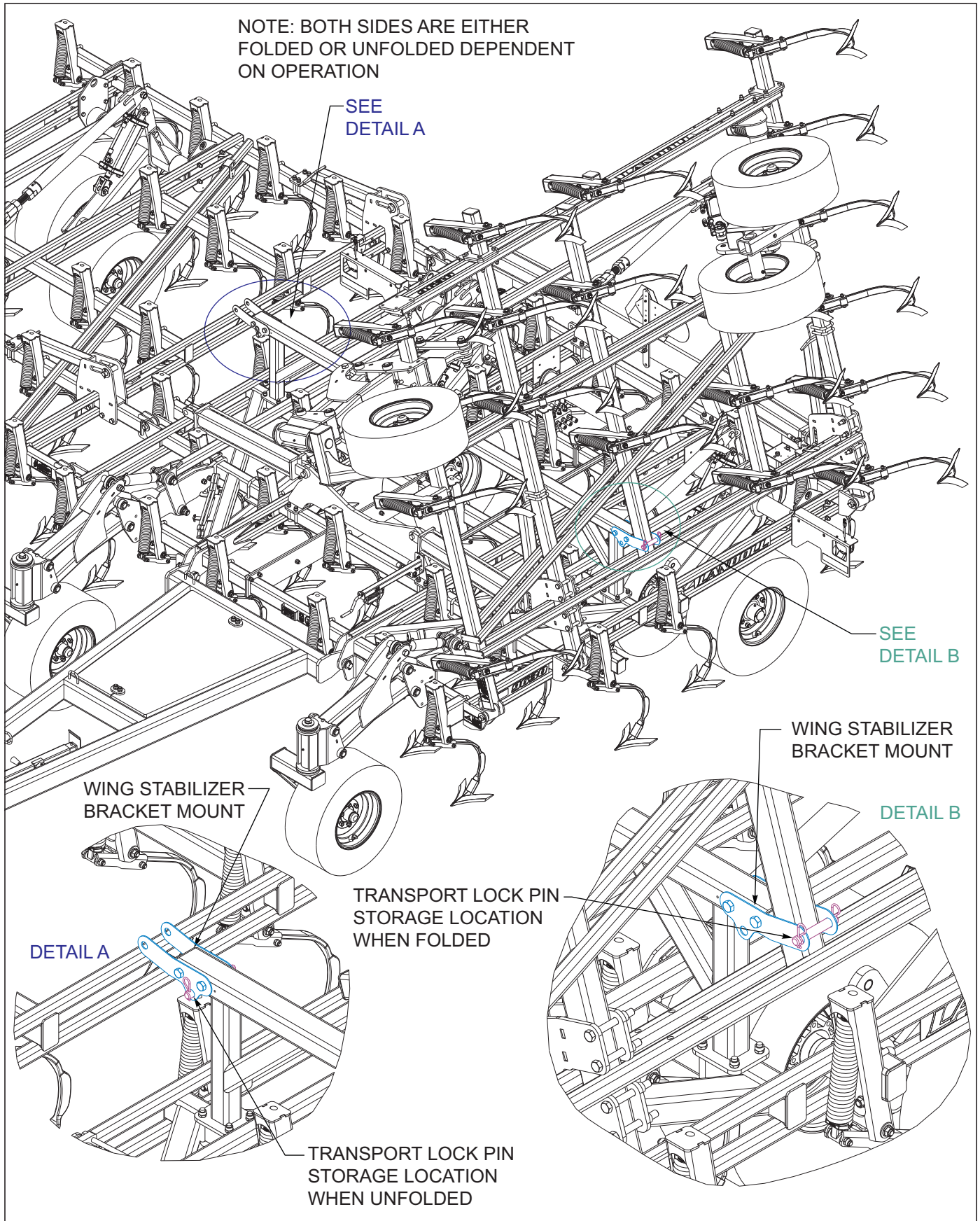

Figure 4-4: Wing Stabilizer Bracket Locks

## Transporting

1. Check and follow all federal, state, and local requirements before transporting the Field Cultivator.
2. The Field Cultivator should be transported only by tractor required for field operation. The implement weight should not exceed more than 1.5 times the tractor weight. Unless noted on the implement, maximum transport speed is 20 mph for the implement and is designated on the speed identification symbol located on the front and rear of the implement [See Figure 4-5](#).

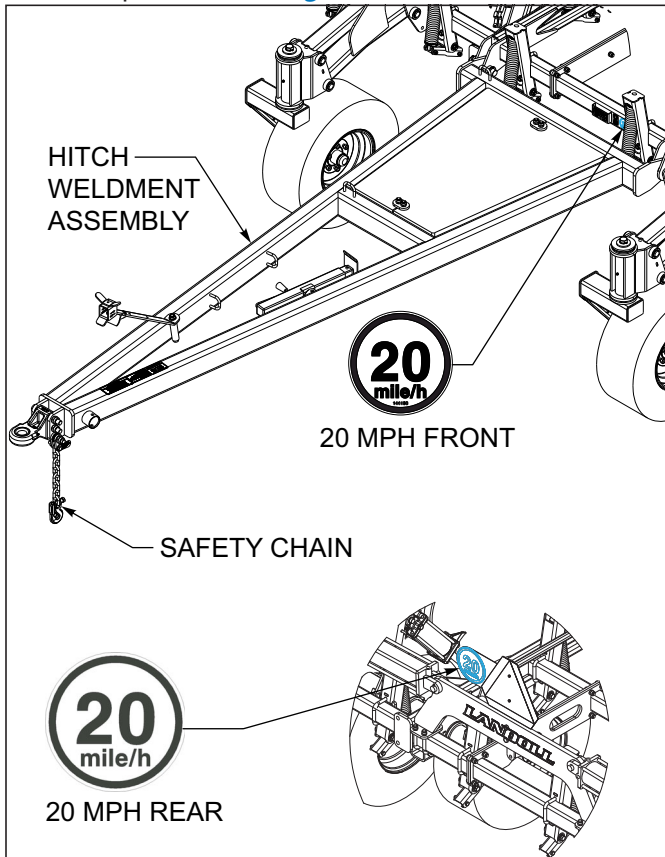

Figure 4-5: Hitch, Speed Identification Symbol, and Safety Chain

3. When towing in combination, the maximum equipment ground speed shall be limited to the lowest specified ground speed of any of the towed implements.
4. Maximum transport speed shall be the lesser of the specified in the operator's manual, speed identification symbol, information sign of the towed implement, or limit of road condition.
5. Slow down when driving on rough roads. Reduce speed when turning, or on curves and slopes to avoid tipping. Equipment altered other than the place of manufacture may reduce the maximum transport speed. Additional weights, added tanks, markers, harrow attachments, etc. may reduce the implements carrying capabilities.
6. A safety chain is provided with the implement to insure safe transport.
7. The safety chain should have a tensile strength equal to or greater than the gross weight of the implement(s). The chain is attached to the lower hitch clevis hole with two flat washers between the clamp plates to assure a tight connection. Always use a 1" diameter Grade 8 bolt for this connection.
8. Attach the safety chain to the tractor drawbar, refer to the tractor operator's manual for proper placement, [See Figure 4-5](#). Provide only enough slack in the chain for turning. Do not use an intermediate chain support as the attaching point for the chain on the tractor. Do not pull the implement by the safety chain.
9. When unhitching from the tractor attach the hook end of the chain to a free link close to the hitch clevis for storage. This will keep the hook off the ground, reducing corrosion and keep the hook functioning properly.
10. Regularly inspect the safety chain for worn, stretched, or broken links and ends. Replace the safety chain if it is damaged or deformed in any way.



### WARNING

Excessive speed may result in the loss of control of the tractor and implement, reduced braking, or failure of the implement tires or structure. Do not exceed the implement maximum specified ground speed regardless of the capability of the maximum tractor speed.



## Tractor Preparation

The Landoll 9630FH Field Cultivator is designed to be pulled by tractor equipped with a double lip or clevis type hitch. If your tractor is not equipped as such, you need to purchase the hitch from your local tractor dealer. Before attaching the Field Cultivator, prepare the tractor as follows:

1. Inflate the rear tractor tires equally and add ballast according to the tractor operator's manual.
2. Lock the tractor drawbar in the center position.

## Prior to Transport

1. Use a locking style hitch pin that properly fits the holes in the tractor drawbar and implement hitch.
2. Attach safety chain.
3. Plug in safety lights to the tractor seven-pin connector.
4. Raise the implement parking jack and place in the field storage position.
5. Make sure all transport locks and pins are installed. Do not depend solely on implement hydraulics for transport.
6. Check that tires are of proper size, load rating, and inflated to manufacture specifications before transporting. Check wheel lug bolts to insure tightness.
7. Know the transport heights and widths of the unit before transporting. Attachments such as leveling harrows can increase the transport dimensions of the implement. Use caution when transporting near bridges and power lines.



### DANGER

**Stay away from power lines when transporting, extending or folding implement. Electrocutation can occur without direct contact.**

8. Verify that all warning lights, SMV sign, reflectors and safety decals are clearly visible and functioning properly. Remove any obstructions such as dirt, mud, stalks or residue that restricts view before transporting.
9. Transport during daylight hours whenever possible. Always use flashing warning lights, except where such use is prohibited by law.

## Leveling (Side to Side)

1. Leveling the Field Cultivator side-to-side involves leveling the center frame then leveling the wing frames to the center frame. The unit should be level side-to-side when operating in the field.
2. To level the unit, verify that all tires are properly inflated. With the implement unfolded, raise the unit to fully extend the lift cylinders. Continue to hold the tractor lever 30-60 seconds to insure that the cylinders are fully extended and the rephasing lift system has been purged of air. Lower the implement until the sweeps are approximately 1" off the ground. On the center frame, lay a straight-edge across the top of the frame, and measure the distance from the walking tandem spindle to the top side of the frame of both walking tandems [See Figure 4-6](#). Adjust the center radius rod at the front of the Field Cultivator center frame until the spindle heights are the same.

### NOTE

*Initially the center frame radius rods should be set to 54" centers before final leveling.*

3. To adjust the radius rod's, loosen the 1-3/4" locking nut against the radius rod tube. Adjust the screw adjustment in or out to the desired setting. An adjusting wrench is provided to make this adjustment. It may be necessary to lower the Field Cultivator to the ground and relieve weight on the lift arms to make this adjustment. If the cultivator has been lowered for adjustments, fully raise the implement, lower to just above the ground, and re-verify measurements. Repeat as necessary and securely tighten the 1-3/4" locking nut when complete.
4. Measure the same distance on the wing frame. The wing frames are generally set 1" higher than the center frame due to difference in tire diameter. Adjusting the radius rod of each wing frame sets wing frame height.

### NOTE

*Initially the wing frame radius rods should be set to 53" centers before final leveling.*

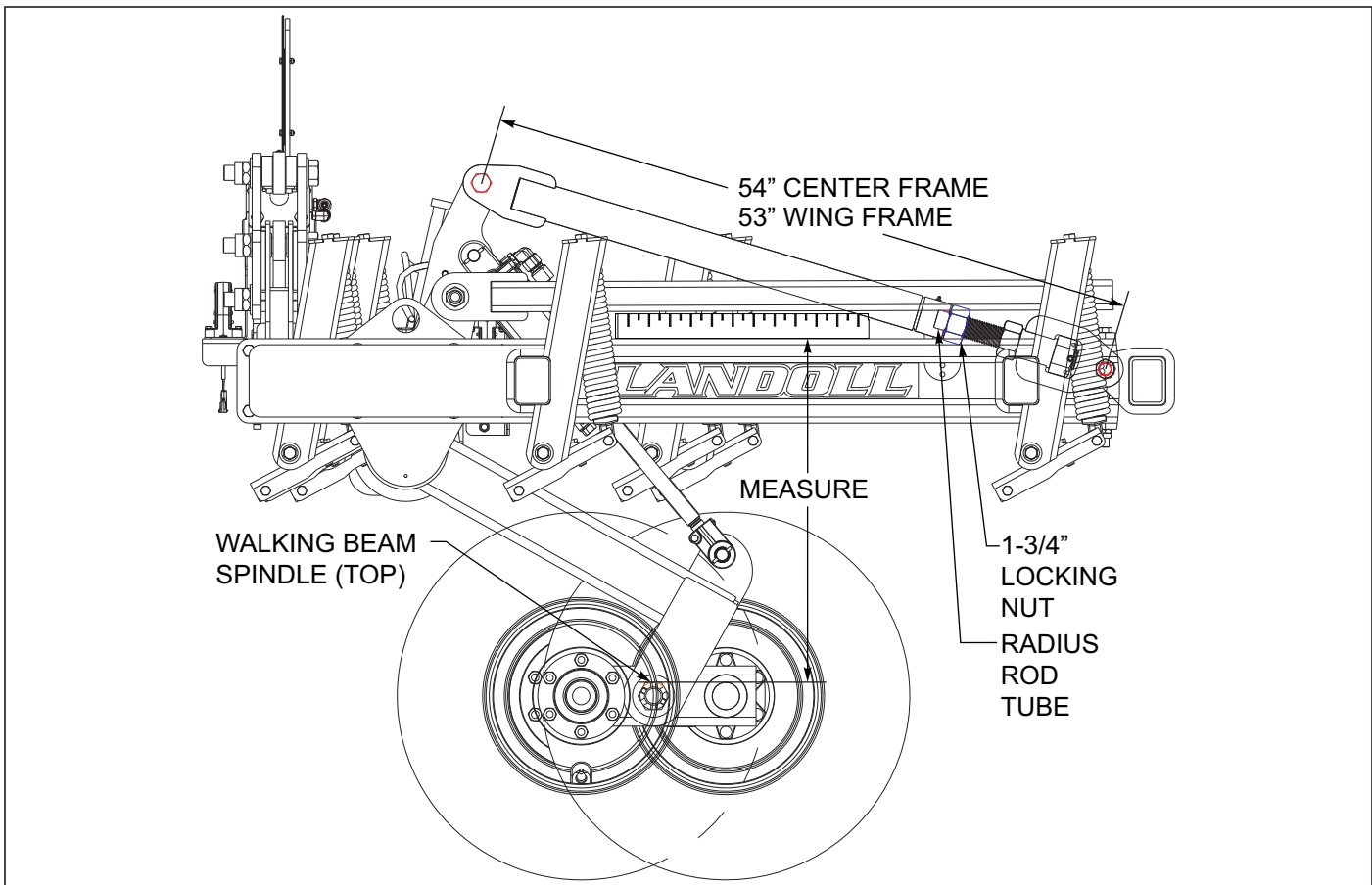

Figure 4-6: Leveling from Side to Side

## 9630FH Gauge Wheels

1. The front gauge wheels of the floating hitch cultivator raise and lower with center and wing lift wheels keeping the frames level during operation. The gauge wheels will caster while making turns with the cultivator.
2. The gauge wheels should be set level with the center frame and wings. Adjustment radius rod at the front of the cultivators is used to level the gauges wheels. To level the cultivator front-to-rear, first level the center and wing lifts side-to-side. Raise the cultivator and rephase the cylinders to make sure the system has been purged of air, then lower the cultivator until the sweeps are approximately 1" above the ground.
3. Measure the distance from the top of the wing frame to the top of the walking beam spindle. Lay a straight edge across the top of the front two center/wing frame shank tubes. Measure from the straight edge to the top of the gauge wheel spindle. This should be 1-1/2" shorter than the main lift measurement from the top of the frame.

### NOTE

Initially the front radius rods are set to 21" centers before final adjustment.

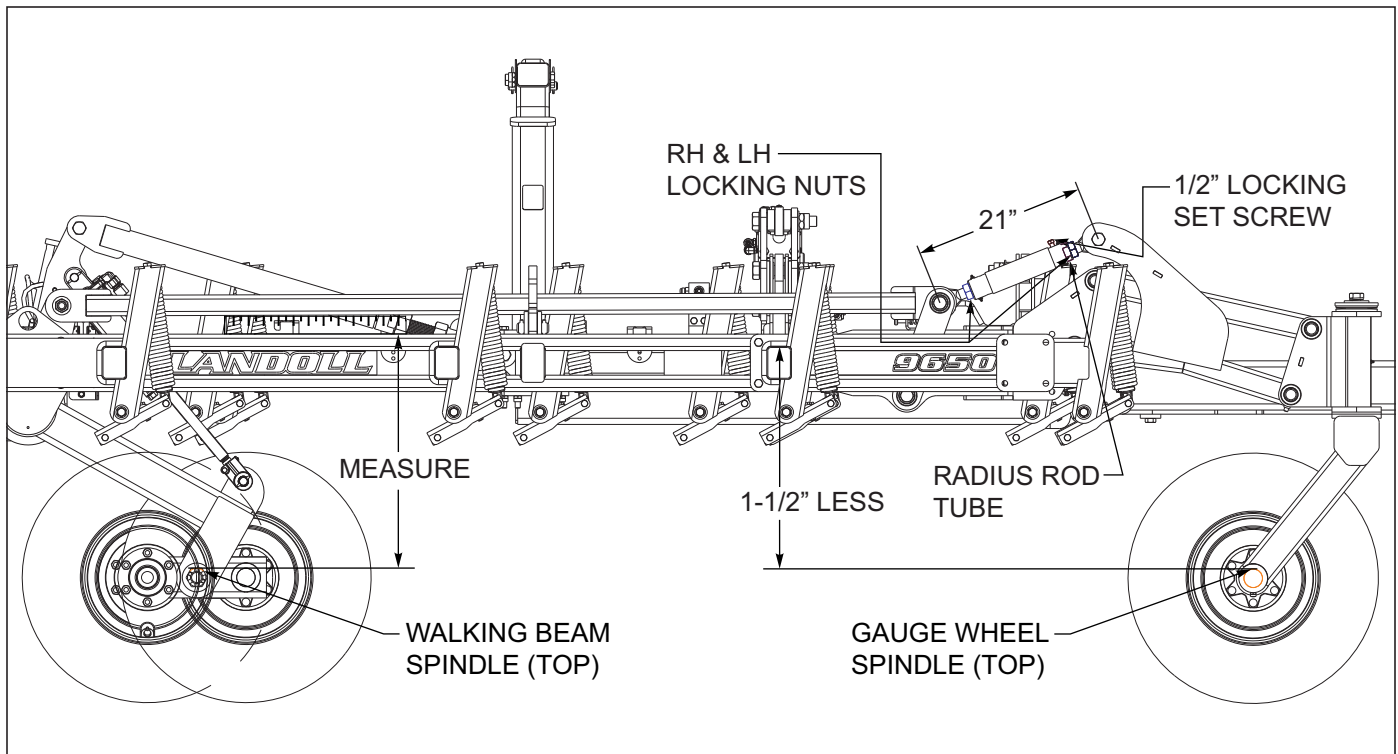

**Figure 4-7: Gauge Wheel Adjustment**

4. To adjust the gauge wheel radius rod, loosen both the right and left-hand threaded locking nuts. Also loosen the  $\frac{1}{2}$ " locking set screw. Adjusting wrenches are provided for the locking nuts. Rotate the radius rod tube to the desired setting. Re-tighten the locking nuts and set screw.

### Depth Stop Adjustment

1. The operating depth of the Field Cultivator is controlled by a single-point depth stop. The stop is located at the center front of the machine *See Figure 4-8.*
2. Adjust the depth stop by turning the handle out (counter-clockwise) to increase operating depth. Turn the handle in (clockwise) to decrease operating depth. One turn will equal approximately 3/16" adjustment in depth. The gauge on the side of the depth stop tube gives a reference for depth setting. The "A" setting refers to maximum operating depth.

#### **IMPORTANT**

**For maximum operating depth, the lift wheels must be in contact with the ground and carry some of the machine weight. Raising the lift wheels off the ground, permits uncontrolled depth of each frame section.**

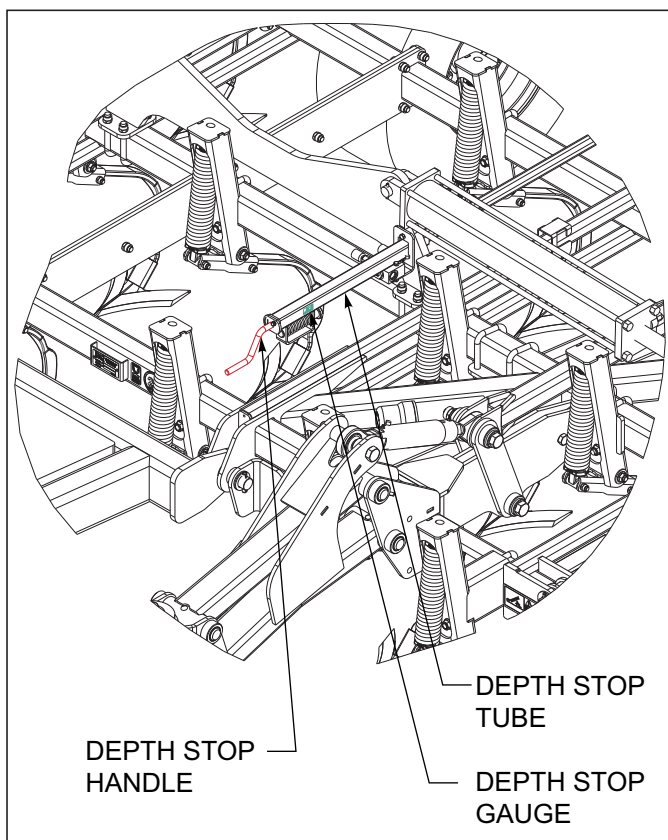

**Figure 4-8: Depth Stop Adjustment**

### LED Light Operation

1. Attach the seven-pin plug to the socket at the rear of the tractor. The socket must be in good working order, and free of dirt, grease, and corrosion. The connection must be clean with good contact for the LED light to function properly. Fully insert the plug into the connector and make sure the latch securely hooks the plug.
2. Allow enough cable above the hitch to allow for turning. Secure or tie up any excess cable to prevent it from catching on the hitch or stalks.
3. Verify proper light function before transporting. Replace or repair any component that is damaged or not functioning. Make sure all lighting is clean and clearly visible. Follow local regulations regarding lighting & marking.

### General Operation

1. The horsepower requirements are typically 6-8 PTO horsepower per foot of cut for the Field Cultivator. This will vary widely due to speed, depth, moisture, residue, and types of soils. Local dealers can help in making recommendations for your areas.
2. Operating speed is typically 5-8 mph. Excessive speed can cause the unit to bounce and create uneven working depth and ridge.
3. Lift wheels must always be in contact with the ground and carrying some implement weight.
4. Avoid turning sharply with the Field Cultivator in the ground. This can put excessive side load on the shanks, harrow, and hitch. Always raise the Field Cultivator completely when making turns or backing to prevent shank damage. Reduce speed at field ends, and raise cultivator before making turns.

## Spring Shank

1. The Field Cultivator may be equipped with spring shanks. The spring shanks feature a 185 lb. point load and a 10" trip height to clear field obstructions. Shanks are 5/8 x 1-3/4 heat treated steel.
2. There is no regular maintenance required on the shanks. The main pivot point of the spring shank has replaceable hardened wear bushings that pivot on a heat treated clamp bushing.

### NOTE

Main pivot bolt should be tightened securely to prevent rotation. Torque main pivot bolt to 140 ft.-lbs.

3. When adjusting/assembling the spring assembly, tighten the upper spring bolt, but leave approximately 1/8" gap above the spring jam nut [See Figure 4-9](#). This will leave the proper clearance for the spring to pivot. Lock the jam nut against the top of the spring, not the top of the mount. Likewise do not over tighten the lower spring cross bolt. Remove any slack in the bolt, but still allow the lower spring to pivot freely.

## Sweeps

1. The spring or s-tine shanks will accept a wide variety of sweeps and points. Recommended sweeps for the cultivator are standard 47° sweeps in 7 to 10 inch widths using 7/16 diameter mounting hardware. Check clearances when using larger sweeps to avoid interference with tires.

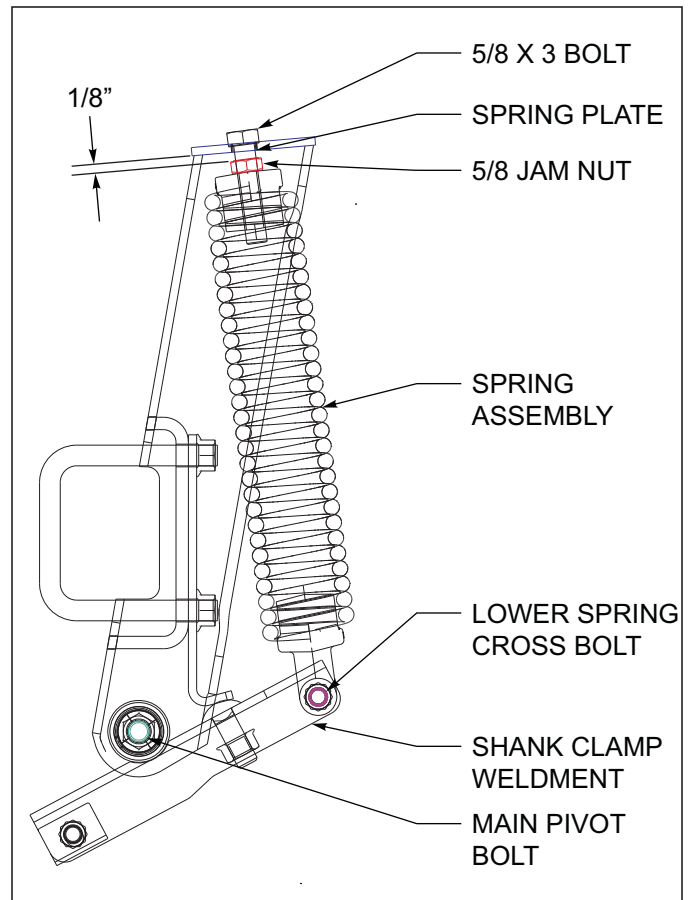

Figure 4-9: Spring Adjustment

## Wheel Bearing Maintenance – Non Triple-Lip

Transport tires use a self-contained seal with multiple lips. The seal fits tight on both the spindle and wheel hub. The seal when properly installed will rotate internally and freely. This seal will also allow grease to pass when lubricating the hub.

Wheel bearing maintenance should be performed at the beginning of every season of use. Check the wheel bearings periodically for excessive end play. If needed, adjust or replace them using the following procedure:

1. Place the frame on blocks or stands sufficiently to lift the tire clear of the ground.
2. Remove the tire.
3. Remove the dust cap, gasket, cotter pin, slotted nut, and washer.
4. Remove the hub assembly from the spindle. Clean and inspect the bearings and hub cavity. Replace any worn or defective parts.
5. Repack the bearings using a high-quality wheel bearing grease.
6. Install the inner bearing into the hub and install the grease seal. Use a driver to install the seal, to avoid damaging the outer edge of the seal. Drive the seal squarely into the hub to avoid any seal distortion.
7. Slide the hub, bearing, and seal onto a clean spindle.
8. Install the outer bearing, washer, and slotted nut.
9. Tighten the slotted nut while rotating the hub until there is a slight resistance to hub rotation. Then back the slotted nut off one notch, until the hub rotates freely without end play.
10. Install the cotter pin, dust cap and gasket  
*See Figure 4-10.*

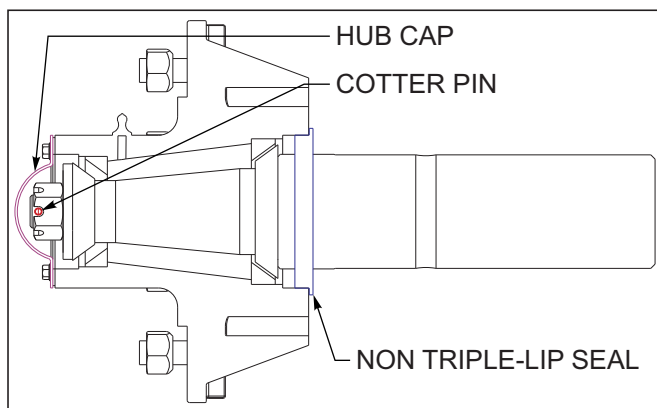

Figure 4-10: Non-Triple Lip Seal

## Wheel Bearing Maintenance -- Triple-Lip

Wheel bearing maintenance should be performed at the beginning of every season of use. Check the wheel bearings periodically for excessive end play. If needed, adjust or replace them using the following procedure:

1. Place the frame on blocks or stands sufficient to lift the tire clear of the ground.
2. Remove the tire.
3. Remove the hub cap, cotter pin, slotted nut and washer.
4. Remove the hub. Clean and inspect the bearings and hub cavity. Replace any worn or defective parts.
5. Repack the bearings using a high-quality wheel bearing grease.
6. Slide the triple-lip seal onto the spindle. Do not install the seal into the hub.
7. Slide the inner bearing cone and hub onto the spindle.
8. Install the outer bearing cone, washer and slotted nut.
9. Tighten the slotted nut while rotating the hub until there is a slight resistance to wheel rotation. Then, back the slotted nut off one notch, until the wheel rotates freely without end play.
10. Slide the triple-lip seal to the hub and install the seal in the hub.

### NOTE

*The triple-lip seals should point away from the hub to keep contaminants out and allow grease to pass* *See Figure 4-11.*

11. Install a new cotter pin and replace the hub cap. *See Figure 4-11.*

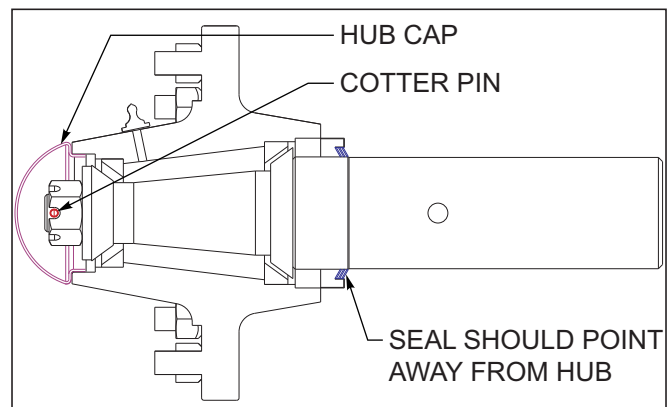
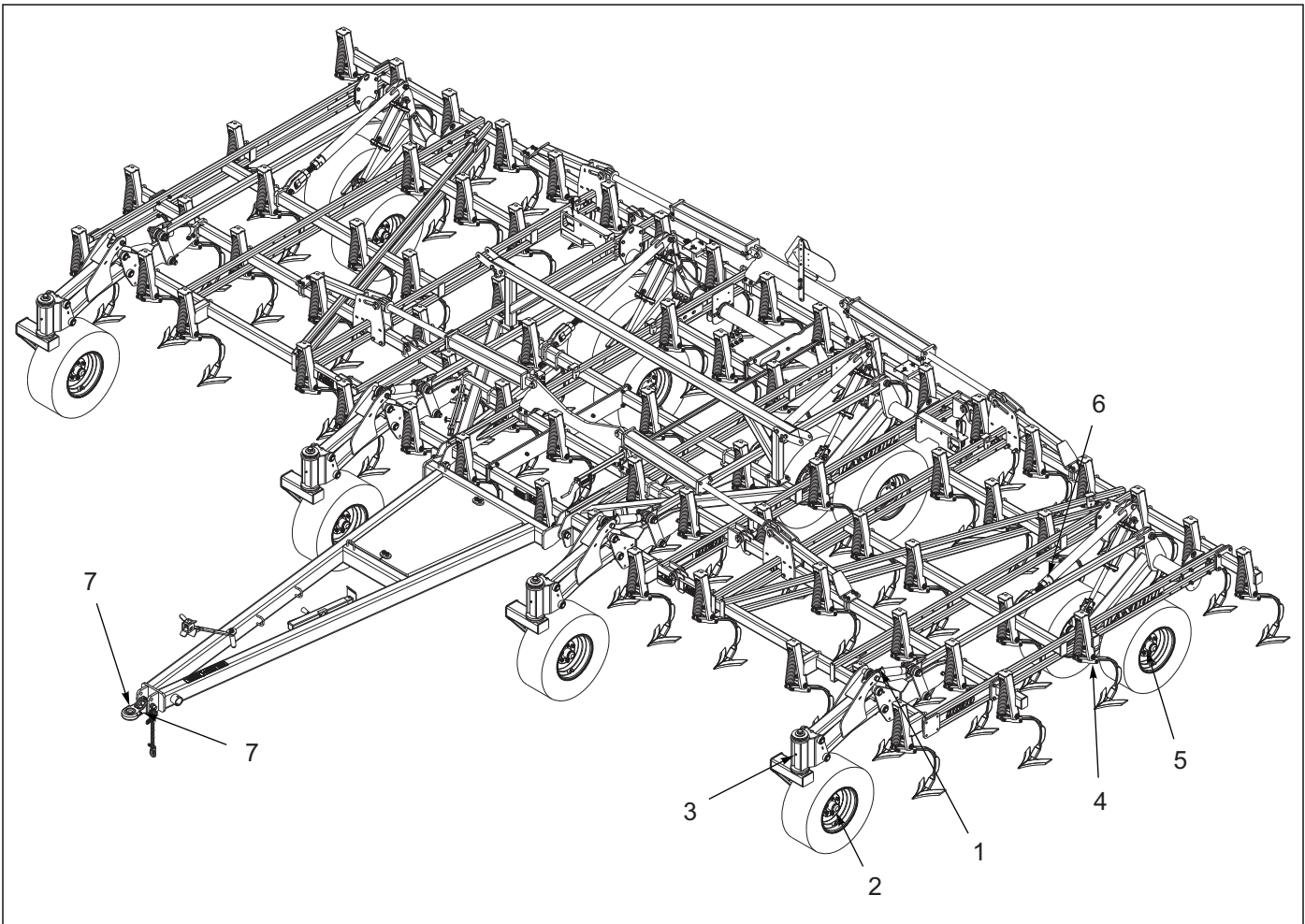

Figure 4-11: Triple Lip Seal

## Lubrication

1. A proper maintenance schedule will insure a long operating life and peak performance. Performing the following lubrication will ensure maximum operating life of the Field Cultivator *See Table 4-1 and See Figure 4-12.*
2. When lubricating the Field Cultivator, SAE multi-purpose EP grease, or EP grease with 3-5% molybdenum sulfide is recommended. Wipe soil from fittings before greasing. Replace any lost or broken fittings immediately.
3. Wheel seals, when properly installed, will allow grease to pass without harm to seals. Regular lubrication will extend service life, particularly in severe operating conditions.
4. The Field Cultivator is equipped with maintenance-free bearings in the wheel lifts, and wing hinges and reel bearings. These areas require no lubrication.



**Figure 4-12: Lubrication Points**

<b>LUBRICATION TABLE</b>			
<b>ITEM</b>	<b>DESCRIPTION</b>	<b>NO. OF LUBE POINTS</b>	<b>INTERVAL (Hours Unless Stated)</b>
1	Gauge Wheel Radius Rod	1 each	50
2	Gauge Wheel Hubs	1 each	50
3	Gauge Wheel Weldment Hubs	1 each	50
4	Walking Beam	1 each	50
5	Lift Hubs	1 each	50
6	Lift Radius Rod	1 each	50
7	Ball Hitch Clevis	2	50

**NOTE**

*Lube all points with high grade multi-purpose grease.*

**Table 4-1: Lubrication Table**





## 4 Row Coil Tine Harrow Adjustments

1. The 4 row coil tine harrow option has 4 rows of 7/16" diameter x 18" long spring steel tines on 16" centers with overall spacing of 2" working centers. Tine rows are on 13" centers for enhanced residue flow. Tine tooth angle is also adjustable from the rear of each section. Each harrow section is mounted with two arms with spring-loaded down pressure. Tine teeth may individually rotate freely backward if needed for backup protection



### WARNING

**Know and verify actual implement height and width before transporting. Attachments may increase the overall height and width of the implement. Use caution when transporting near power lines. Electrocution can occur without direct contact.**

2. In general tine harrows have better capabilities for handling more residue and wetter conditions. When operating the coil tine harrow, a more vertical tine tooth angle will make the harrow more aggressive. A lower/flatter tine angle will make the harrow less aggressive but will handle more residue and wetter conditions. To change the tine angle, raise the harrow off the ground. Remove the harrow pin from both angle adjustment tubes per tine gang bar tube [See Figure 4-13](#). Rotate the angle adjustment tubes forward (less aggressive) or rearward (more aggressive) and reinstall both spring clip pins. Repeat the tine adjustment for each tine gangbar tube and harrow section.
3. The initial setting for the spring assembly should be 22". Each harrow section may also be adjusted for operating height. To change the harrow height [See Figure 4-13](#), loosen both 1-8 hex nuts. Raise or lower the harrow arm by turning the bolt head for the spring adjustment bolt. Then re-tighten the 1-8 hex nuts. When initially setting the harrow height, the bottom tips of the tine tooth (pulled back at the desired tooth angle) should be approximately level with the field cultivator sweeps.

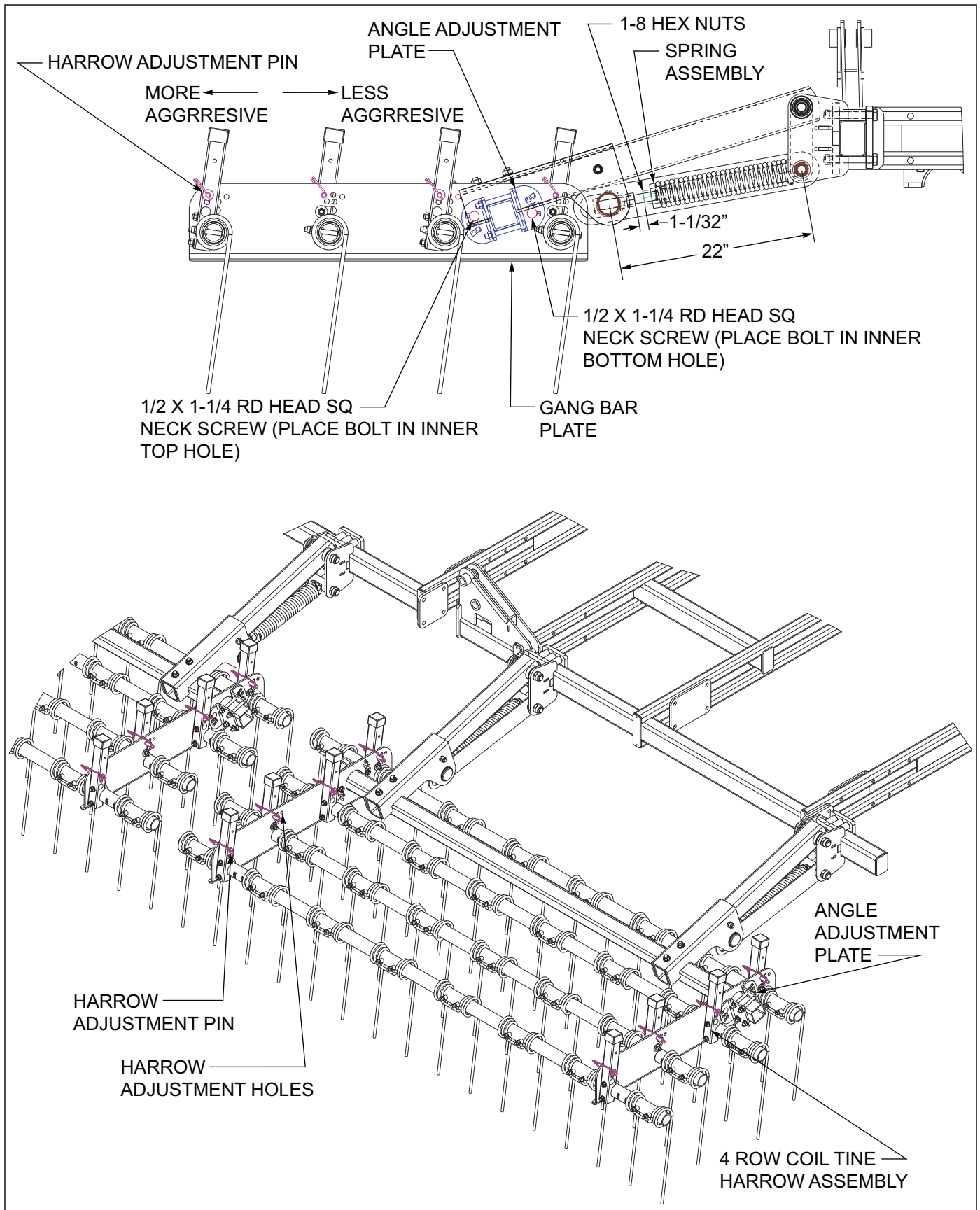

Figure 4-13: 4 Row Coil Tine Adjustment

### 3 Row Coil Tine and Reel Adjustments

1. The optional 3 row coil tine and reel attachment consists of a 3 row coil tine and finishing reel combination harrow that operate independently from each other. The 3 row coil tine reel harrow performs best in clean dry ground with minimal residue, to level, break up clods, and firm soil.
2. The 3 row coil tine harrow option has 3 rows of 7/16" diameter x 18" long spring steel tines on 16" centers with overall spacing of 2" working centers. Tine rows are on 14" centers for enhanced residue flow. Tine tooth angle is also adjustable for each tine bar end section. Each harrow section is mounted with two arms with spring-loaded down pressure. Tine teeth may individually rotate freely backward if needed for backup protection



#### WARNING

**Know and verify actual implement height and width before transporting. Attachments may increase the overall height and width of the implement. Use caution when transporting near power lines. Electrocutation can occur without direct contact.**

3. In general tine harrows have better capabilities for handling more residue and wetter conditions. When operating the coil tine harrow, a more vertical tine tooth angle will make the harrow more aggressive. A lower/flatter tine angle will make the harrow less aggressive but will handle more residue and wetter conditions. To change the tine angle, raise the harrow off the ground. Remove the harrow pin from both angle adjustment tubes per tine gang bar tube [See Figure 4-14](#). Rotate the angle adjustment tubes forward (less aggressive) or rearward (more aggressive) and reinstall both spring clip pins. Repeat the tine adjustment for each tine gang bar tube and harrow section.

4. Each coil tine harrow may be adjusted for spring pressure as well [See Figure 4-14](#). Raise the tine harrow off the ground. Remove the clevis pin from the spring tube and install in a heavy or light setting as needed. **Excessive spring pressure and tine angle can overload harrow spring.**

#### NOTE

*The tine teeth will hang straight down when the implement is raised, and the tines will be slightly lower than the sweeps.*

5. To adjust the reel height, loosen the locking hex nut against the threaded spring end [See Figure 4-14](#).
6. Raise or lower the reel by turning the head of the spring bolt, and then re-tighten the locking nut against the spring end. Initially set the bottom of the reel even with the bottom of the sweeps. In lighter or wet soils, you may need to raise the reels slightly above the sweeps. Setting the reels too low may cause the reels to plug or push dirt. Excessive reel depth/down pressure may hold the rear of the field cultivator out of the ground.
7. Reels are equipped with maintenance-free bearings.

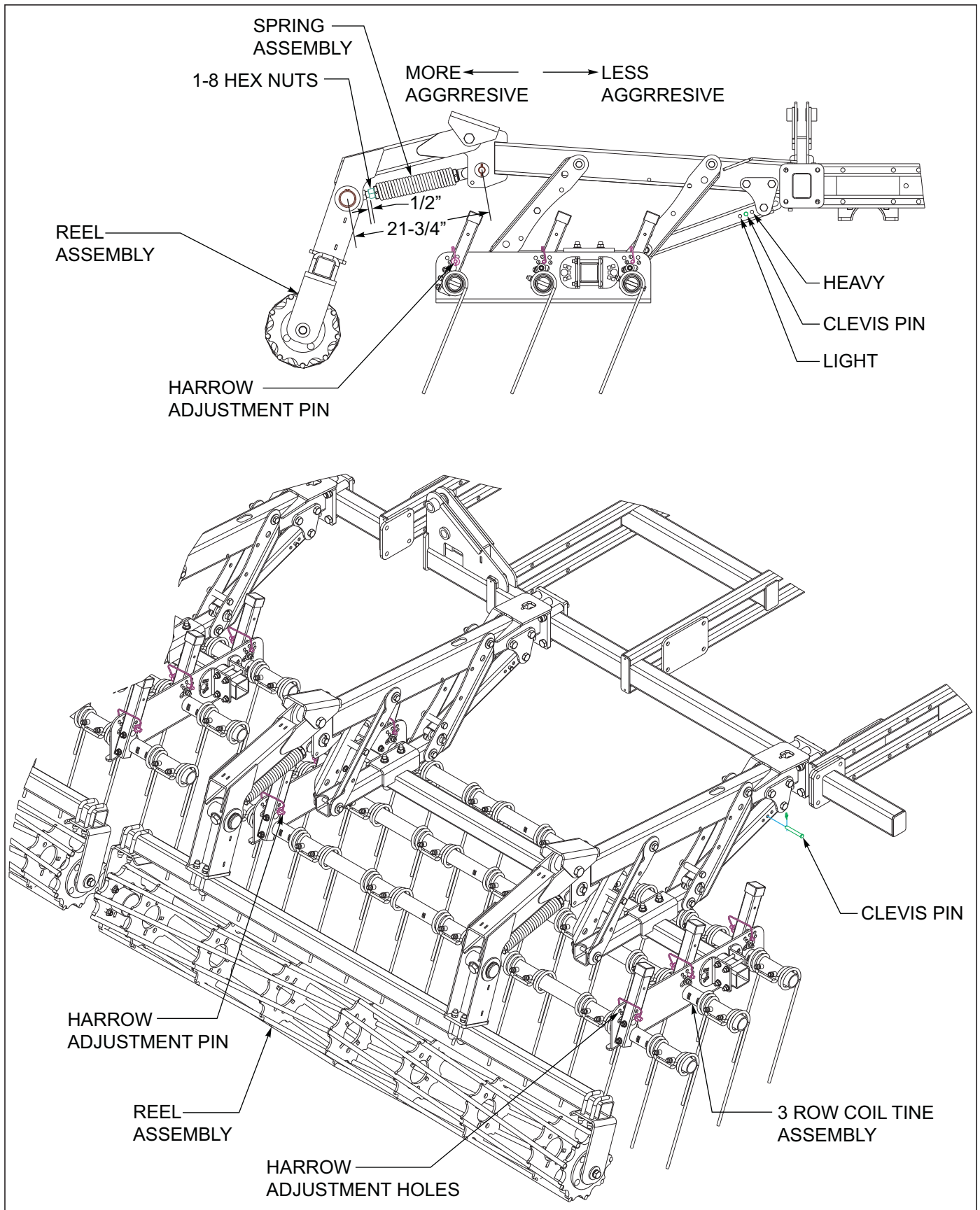

Figure 4-14: 3 Row Coil Tine and Reel Adjustments

### 5 Row Spike Harrow Adjustments

1. The 5 row spike harrow optional attachment consists of 5 rows of 3/4" x 14" long spike teeth, spaced on 9" centers. The spike teeth effectively work on 1.8" centers. Rank spacing for the angle iron bars is 14". Angle iron bars are able to float over contours and have backup protection. Spike tooth angle has a three position adjustment to either stand the teeth up for more aggressive action, or to lay the tooth down for lower aggressiveness and better residue clearance. The 5 row spike harrow performs best in clean ground with minimal residue, to level and break up clods.



#### WARNING

**Know and verify actual implement height and width before transporting. Attachments may increase the overall height and width of the implement. Use caution when transporting near power lines. Electrocutation can occur without direct contact.**

2. For the most aggressive spike to action, install the harrow adjustment pin in the forward mounting hole over each bar clamp for each spike bar **See Figure 4-15**. This will position the spike teeth to be in the most vertical position. In wetter or conditions with some residue, lower the spike tooth angle by positioning the harrow adjustment pin in the middle or rear hole. This will allow the teeth to lay flatter and shed more residue.
3. The forward pull chain will also influence how the 5 row spike operates as well **See Figure 4-15**. A taller pull point and shorter adjusted pull chain can help to start residue through the harrow. A lower pull point with a longer adjusted pull chain will help the entire harrow to run flatter from front-to-rear, and be more aggressive for increased leveling. When adjusting the pull chain, insert the desired pulling link through the slotted hole in the pull chain bracket, and install a lynch pin thru the link to secure the chain in place. Make sure the pull chains are set evenly for each section.

#### NOTE

***Do not extend the pull chain out so far that the vertical carrying chains are pulling the harrow through the field.***

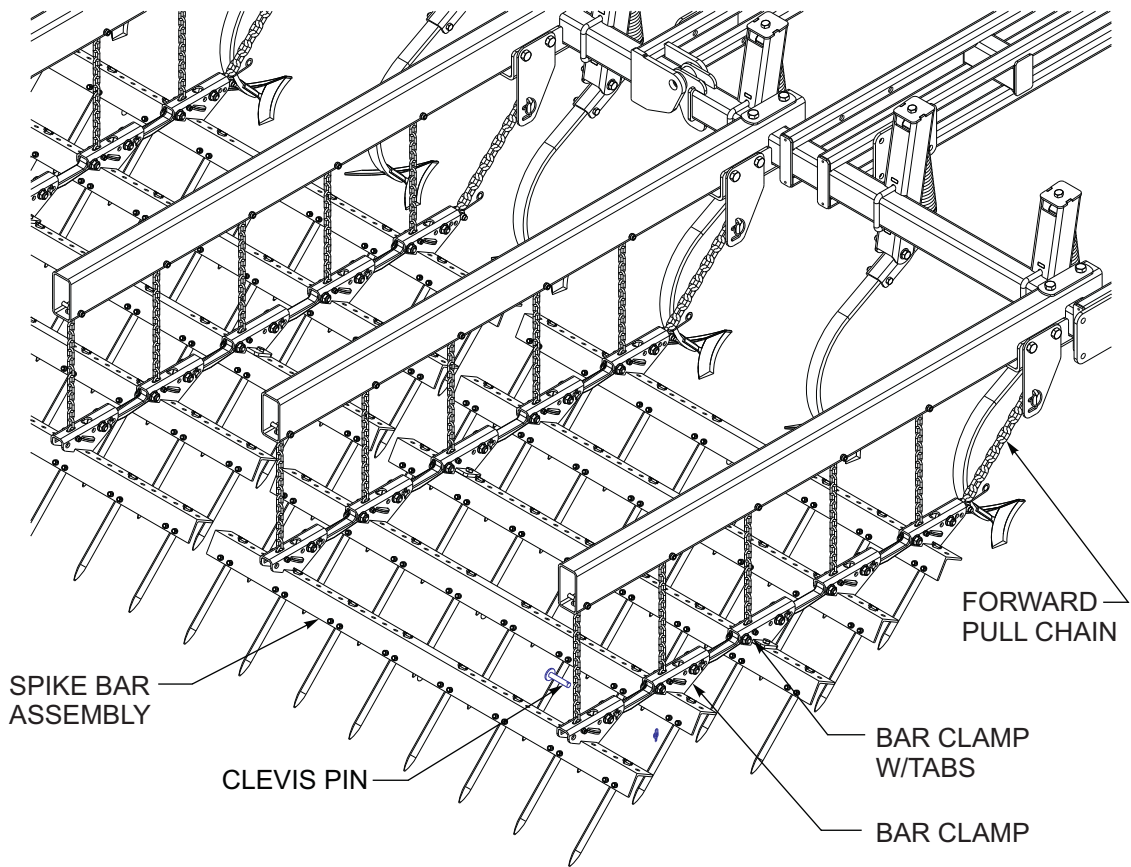
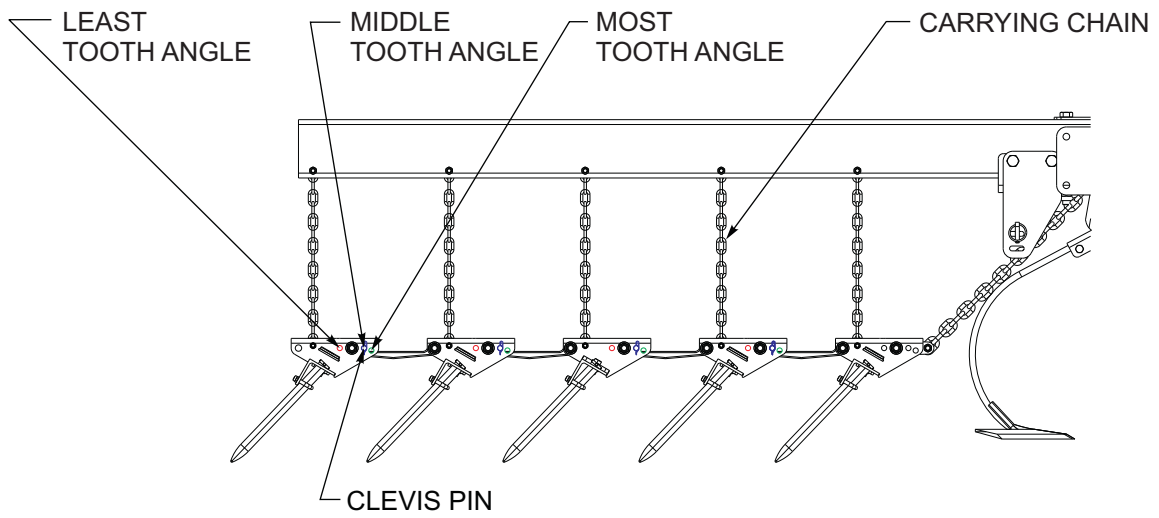

Figure 4-15: 5 Row Spike Harrow Adjustments

### 3 Row Spike and Reel Adjustments

1. The optional 3 row spike and reel attachment consists of a 3 row spike and finishing reel combination harrow that operate independently from each other. The 3 row spike reel harrow performs best in clean dry ground with minimal residue, to level, break up clods, and firm soil.



#### WARNING

**Know and verify actual implement height and width before transporting. Attachments may increase the overall height and width of the implement. Use caution when transporting near power lines. Electrocution can occur without direct contact.**

2. The 3 row spike consists of 3 rows of 3/4" x 14" long spike teeth, spaced on 9" centers. The spike teeth effectively work on 3.6" centers. Rank spacing for the angle iron bars is 14". Angle iron bars are able to float over contours and have backup protection. Spike tooth angle has a three position adjustment to either stand the teeth up for more aggressive action, or to lay the teeth down for less aggressiveness and better residue clearance.
3. For the most aggressive spike tooth action, install the harrow adjustment pin in the forward mounting hole over each bar clamp for each spike bar [See Figure 4-17](#). This will position the spike teeth to be in the most vertical position. In wetter or conditions with some residue, lower the spike tooth angle by positioning the harrow adjustment pin in the middle or rear hole. This will allow the teeth to lay flatter and shed more residue.
4. The forward pull chain will also influence how the 3 row spike operates as well. A taller pull point and shorter adjusted pull chain can help to start residue through the harrow. A lower pull point with a longer adjusted pull chain will help the entire harrow to run flatter from front-to-rear, and be more aggressive for increased leveling. When adjusting the pull chain, insert the desired pulling link through the slotted hole in the pull chain bracket, and install a lynch pin thru the link to secure the chain in place. Make sure the pull chains are set evenly for each section.

#### NOTE

**Do not extend the pull chain out so far that the vertical carrying chains are pulling the harrow through the field, or that the spike harrow gets into the reel.**

5. The 12" diameter reel consists of nine 3/4" diameter round bars with a chevron shape for smoother rotation. The reels have no inner shaft to reduce plugging in wetter conditions. The reels operate independently of the 3 row spike with two spring loaded arms per reel to maintain consistent down pressure. A 12" diameter spiral wound reel with 1/4 x 1-1/2 angled blades is also available. The blades on flat bar reels are angled for more aggressive action. Install the reels as shown [See Figure 4-16](#).

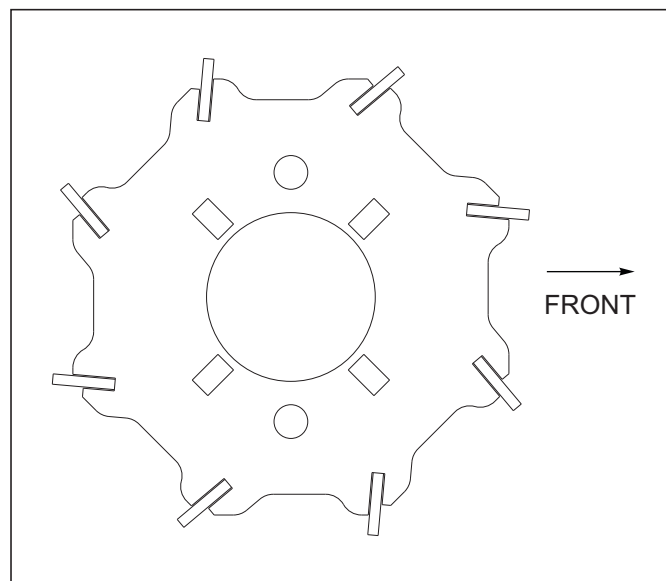

**Figure 4-16: Flat Reel**

6. To adjust the reel height, loosen the locking hex nut against the threaded spring end.
7. Raise or lower the reel by turning the head of the spring bolt, and then re-tighten the locking nut against the spring end. Initially set the bottom of the reel even with the bottom of the sweeps. In lighter or wet soils, you may need to raise the reels slightly above the sweeps. Setting the reels too low may cause the reels to plug or push dirt. Excessive reel depth/down pressure may hold the rear of the field cultivator out of the ground.
8. Reels are equipped with maintenance-free bearings.



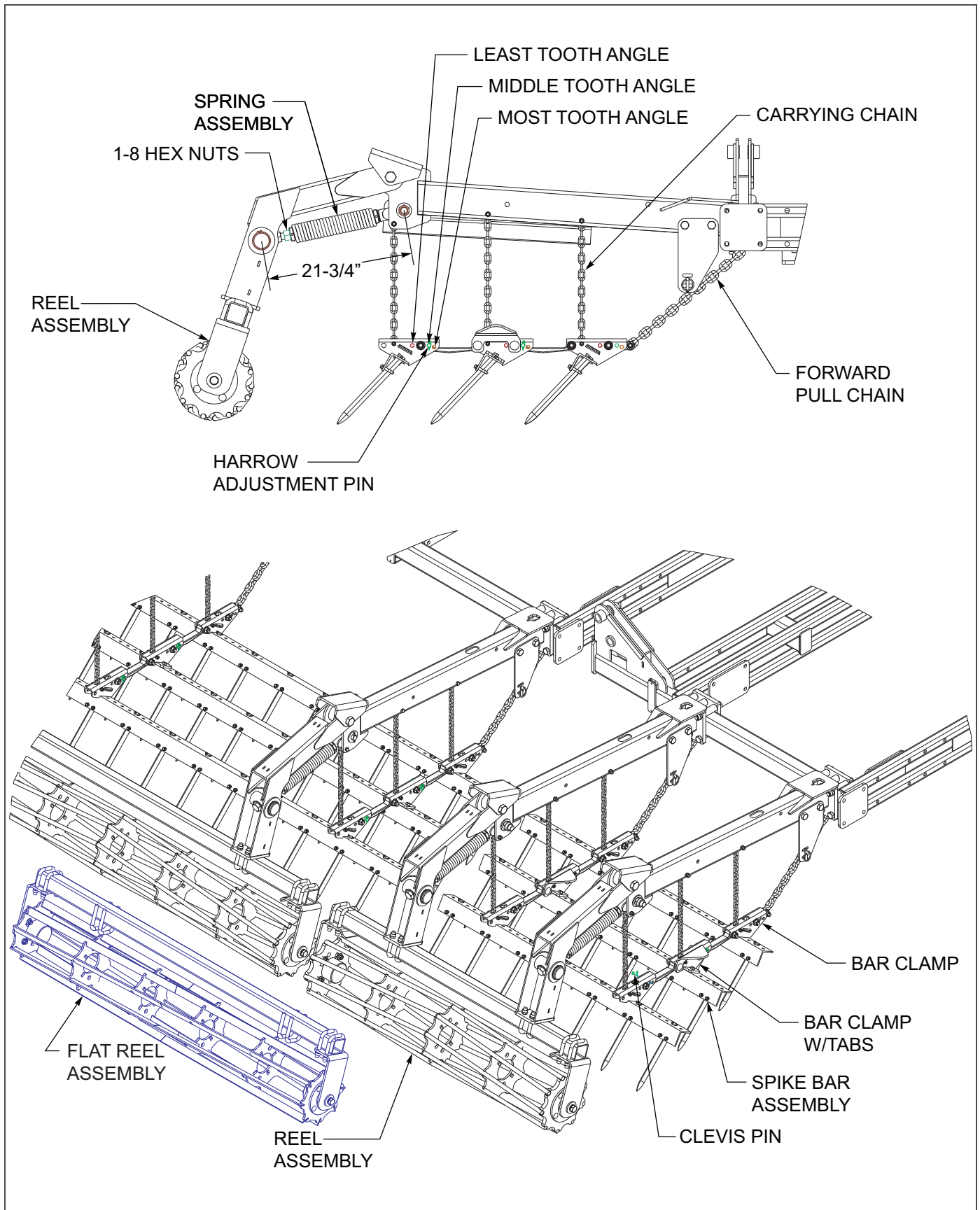

Figure 4-17: 3 Row Spike and Reel Adjustments

### Storage

1. The service life of the Field Cultivator will be extended by proper off-season storage practices. Prior to storing the unit, complete the following procedures:
  - a. Completely clean the unit.
  - b. Inspect the machine for worn or defective parts. Replace as needed.
  - c. Repaint all areas where the original paint film is worn off.
  - d. Grease all exposed metal surfaces of shanks, points.
  - e. Lubricate each point of the machine as stated in ***“Lubrication” on page 4-13.***
  - f. Store the unit in a shed or under a tarpaulin to protect it from the weather. The ground tools and tires should rest on boards, or some other object, to keep them out of the soil **See Section 7, *“Hydraulic Fold System” on page 4-4 .***

## Troubleshooting Guide

The Troubleshooting Guide, shown below, is included to help you quickly locate problems that can happen using your 9630FH Field Cultivator. Follow all safety precautions stated in the previous sections when making any adjustments to your machine.

PROBLEM	PROBABLE CAUSE	SOLUTION
FIELD NOT LEVEL BEHIND FIELD CULTIVATOR	Wing(s) not level with center frame	Hydraulic lift cylinders out of phase. Raise field cultivator and hold hydraulic lever until all lift cylinders are completely extended.
		Fully extend all wing fold cylinders to allow wings to flex over uneven ground
		Level machine side-to-side, by adjusting wing lift arms, so wing frames operate same depth as center frame.
	Hydraulic cylinder leaking	Repair cylinder.
	Unit not level front-to-rear	Adjust gauge wheel radius rod to level unit.
	Harrow improperly set	Adjust all harrow sections to operate the same depth
Increase harrow depth or increase tine/tooth angle to be more aggressive.		
UNEVEN DEPTH	Wing(s) not level with center frame	Level center frame side to side
		Level wing frames to center frame
		Lift cylinders not in phase. Fully extend lift cylinders and hold hydraulic lever until all cylinders are fully extended
		Lift wheels not carrying enough weight, adjust depth stop and raise implement
		Fold cylinders not fully extended to allow wings to flex
	Incorrect tire pressure	Tire pressure too low, check inflation
Unit not level front-to-rear	Unit not level front to rear	
UNIT TRACKS TO ONE SIDE	Wing(s) not level with center frame	Level unit side to side
	Unit not level front-to-rear	Adjust gauge wheels
	Hydraulic cylinder leaking	Repair cylinder.
	Gauge wheels improperly set	Gauge wheels too high or not evenly across machine
UNIT BOUNCES IN THE FIELD	Operating too fast	Typical operating speed 5-8 mph
	Conditions too rough for speed	Make two passes if necessary
SHANKS PLUG WITH RESIDUE	Shanks not positioned correctly	Check for proper shank placement
	Shank extensions not installed on spring shanks	Check for proper shank placement
SHANK SPRINGS BREAKING	Lower spring pivot bolt too tight.	Lower spring bolt must be loose enough that spring end casting may pivot freely.
	Upper spring bolt too tight.	Should be 1/8 clearance between jam nut and top spring plate.
		Locking jam nut should be tight against spring end, not top spring plate

## TROUBLESHOOTING GUIDE

PROBLEM	PROBABLE CAUSE	SOLUTION
SWEEPS NOT CUTTING, LEAVING SKIPS	Shanks not positioned correctly	Check for proper shank placement
	Sweeps not wide enough	Use wider sweeps
	Sweeps set too shallow	Increase operating depth
	Incorrect sweep angle	Use 47 degree sweeps
	Incorrect shank spring adjustment	Adjust spring shank.
	Bent/broken/loose shank or sweep	Repair shank or sweep
WINGS FOLD TOO FAST	Restrictors not properly installed in cylinders	Black restrictor fittings should be in both ends of outer fold cylinders and rod end of inner fold cylinders.
HYDRAULIC - LIFT CYLINDERS NOT FULLY EXTENDING	Lift cylinders not in phase.	Fully extend cylinders and hold hydraulic lever until all cylinders are fully extended
	Cylinders not installed in proper series.	Cylinders not installed in proper series. Wing cylinders are smaller diameter than center cylinders
	Center frame not level side-to-side	Adjust cylinder Bent center lift
	Hoses not properly connected	Check hose routing
HYDRAULIC - ENTIRE UNIT SETTling	Tractor valve leaking	Unplug unit from tractor, and check if unit still settling
	Bad fitting/hose	Repair fitting/hose
HYDRAULIC - UNIT SETTling, ONE WING RAISING	Center frame cylinder leaking internally on side of unit that wing is raising.	Repair center frame master cylinder.
HYDRAULIC - WING SETTling	Wing cylinder leaking	Repair wing cylinder
HYDRAULIC - UNIT WILL NOT FOLD/UNFOLD	Bad Couplers	Replace hydraulic couplers
	Tractor valve not Working	Try a different known working valve
HYDRAULIC - DEPTH CONTROL VALVE NOT WORKING	Hydraulic hoses not properly connected	Check hose connections
	Depth stop contacts depth control valve, but does not shut off oil.	Valve plumbed incorrectly
		Valve leaking internally.
Implement raises, but will not lower	Valve or manifold plumbed incorrectly	
WHEEL BEARING FAILURE	Seals not properly installed	Triple-lip seals should be installed with lips pointing outward away from the hub.
HARROW PLUGS WITH RESIDUE	Harrow set too aggressive	Reduce tine/tooth angle to allow residue to flow thru harrow
	Harrow spring pressure excessive	Harrow operating too deep, reduce spring pressure/raise harrow.
HARROW REELS PLUGGING	Excessive down pressure	Reels operating too deep, reduce spring pressure/raise harrow.
HARROW REELS WILL NOT TURN OR PUSH SOIL	Depth set too deep for loose or wet conditions	Adjust reel operating depth
	Reel bearing failure	Repair reel bearing.

**Document Control Revision Log:**

<b>Date</b>	<b>Form #</b>	<b>Improvement(s): Description and Comments</b>
11/20/2020	F-1105	New Manual
12/17/2020	F-1105-1220	Initial Release
01/24/2022	F-1105-0122	Hydraulic updates, added QR code to frame



---

# Intertek

Equipment from Landoll Company, LLC is built to exacting standards ensured by ISO 9001 registration at all Landoll manufacturing facilities.

## Model 9630FH Field Cultivator Operator's Manual

Re-Order Part Number F-1105-0122

### LANDOLL COMPANY, LLC

1900 North Street

Marysville, Kansas 66508

(785) 562-5381

800-428-5655 ~ [WWW.LANDOLL.COM](http://WWW.LANDOLL.COM)



Copyright 2022. Landoll Company, LLC

“All rights reserved, including the right to reproduce this material or portions thereof in any form.”

Scan to go to [www.landoll.com](http://www.landoll.com)

