

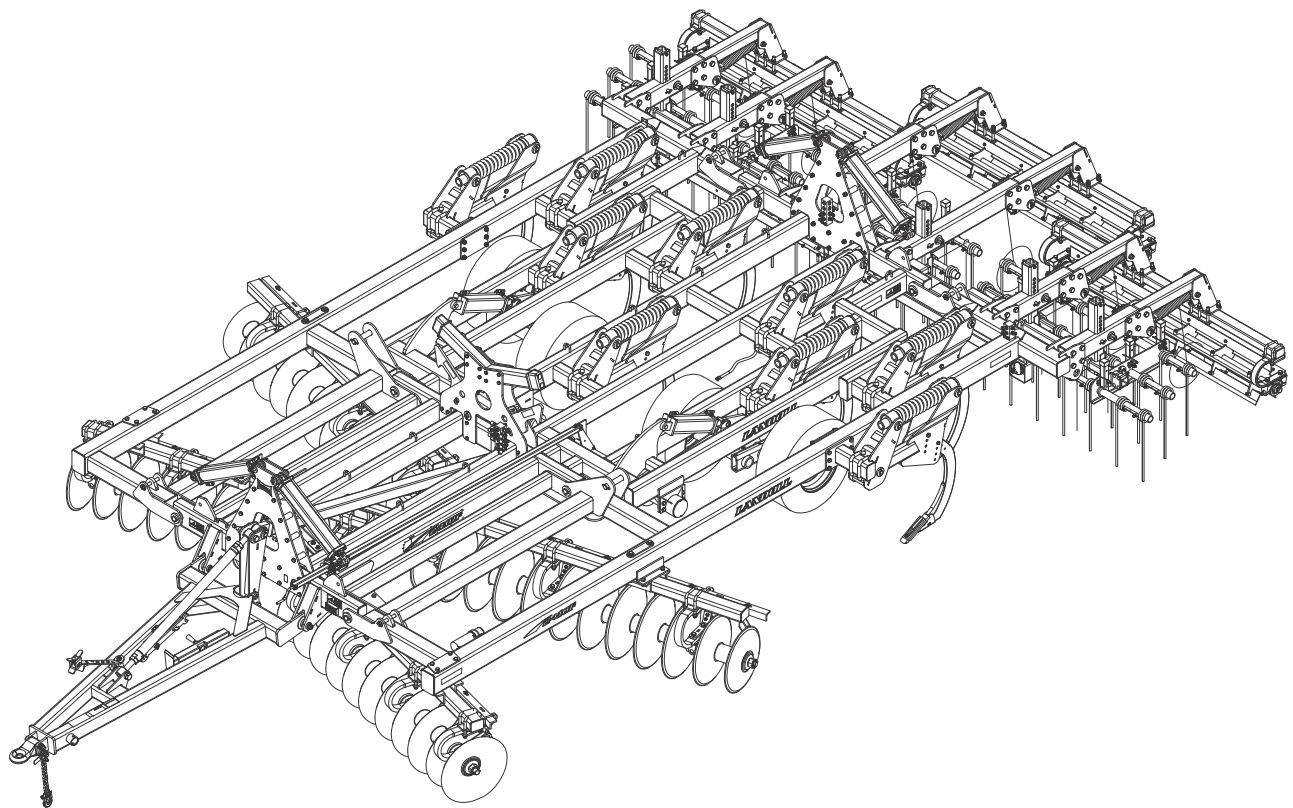

# Model 2410F Weatherproofer I Operator's Manual



## **LANDOLL CORPORATION**

1900 North Street  
Marysville, Kansas 66508  
(785) 562-5381

800-428-5655 ~ [WWW.LANDOLL.COM](http://WWW.LANDOLL.COM)



## 1 Introduction and Safety Information

<b>Introduction</b> .....	<b>1-1</b>
<b>Understanding Safety Statements</b> .....	<b>1-2</b>
Decal Safety .....	1-2
Transporting Safety .....	1-2
Attaching, Detaching, and Storage .....	1-3
Maintenance Safety .....	1-3
High Pressure Fluid Safety .....	1-3
Protective Equipment .....	1-3
Chemical Safety .....	1-3
Prepare for Emergencies .....	1-3
Tire Safety .....	1-3
Safety Chain .....	1-4

## 2 Standard Specifications

<b>Model Specifications</b> .....	<b>2-1</b>
<b>General Torque Specifications (rev. 4/97)</b> .....	<b>2-2</b>
<b>Hydraulic Fitting Torque Specifications</b> .....	<b>2-3</b>

## 3 Assembly Instructions

<b>Weatherproofer I Frame Assembly</b> .....	<b>3-3</b>
<b>Wheel Lift Installation</b> .....	<b>3-5</b>
<b>Weatherproofer I Wing and Extension Installation</b> .....	<b>3-7</b>
<b>Hitch Installation</b> .....	<b>3-9</b>
<b>Depth Stop Tube Assembly</b> .....	<b>3-11</b>
<b>Disc Gang Installation - Wing Frame</b> .....	<b>3-13</b>
<b>Auto Reset Shank and Point Installation</b> .....	<b>3-15</b>
<b>Hydraulic Installation</b> .....	<b>3-19</b>
<b>Light Installation</b> .....	<b>3-21</b>
<b>Finishing Combo w/ Chopper Reel Installation (Option)</b> .....	<b>3-25</b>
<b>Finishing Combo w/ Conditioner Reel Installation (Option)</b> .....	<b>3-27</b>
<b>Finishing Chopper Reel Installation (Option)</b> .....	<b>3-31</b>
<b>Finishing Conditioner Reel Installation (Option)</b> .....	<b>3-33</b>
<b>Finishing Harrow Installation (Option)</b> .....	<b>3-35</b>

---

Final Assembly .....	3-36
----------------------	------

## **4 Operation and Maintenance**

Tractor Preparation .....	4-2
Weatherproofer Preparation .....	4-2
Attaching to the Tractor .....	4-2
Hydraulic Lift System .....	4-3
General Operation .....	4-4
Field Operation .....	4-4
Leveling (Front-to-Rear) .....	4-4
Disc Blades .....	4-5
Depth Stop Adjustment (Manual) .....	4-5
Wheel Bearing Maintenance .....	4-6
Hydraulic Maintenance .....	4-7
Transport .....	4-7
Lubrication Maintenance .....	4-10
Storage .....	4-10

## **5 Troubleshooting Guide**

## Introduction and Safety Information

---

### Introduction

The Landoll Model 2410F Weatherproofer 1 is a quality product designed to give years of trouble free performance. By following each section of this manual, your system will perform as designed for you and your operation.

- CHAPTER 1** Gives basic instructions on the use of this manual and understanding the safety statements.
- CHAPTER 2** Gives product specifications for the equipment. These specifications supply lengths and measures for your equipment. A Standard Bolt Torque Table is provided to give guidelines for bolt torques to be used when servicing this product.
- CHAPTER 3** Contains assembly instructions for your 2410F Weatherproofer 1. When these procedures are correctly followed, your equipment should provide you years of trouble-free operation and service.
- CHAPTER 4** Instructs how to operate your equipment before using it, and describes adjustments needed. Gives practical advice for the care and maintenance of your Landoll equipment. Drawings in this section locate adjustment points on the equipment.

**IF YOU HAVE ANY QUESTIONS CONTACT:  
LANDOLL CORPORATION  
1900 NORTH STREET  
MARYSVILLE, KANSAS 66508**

**PHONE # (785) 562-5381 or (800) 428-5655  
OR  
FAX # (888) 527-3909**

- CHAPTER 5** Is a troubleshooting guide to aid in diagnosing and solving problems with the Weatherproofer 1
- PARTS MANUAL** Is a separate manual showing the various assemblies, subassemblies, and systems. Refer to that manual when ordering Landoll replacement parts. Order parts from your Landoll dealer.
- WARRANTY** The Warranty Registration form is included with the product documents. Fill it out and mail it within 15 days of purchase.  
**NOTE: IMPROPER ASSEMBLY, MODIFICATION, OR MAINTENANCE OF YOUR LANDOLL MACHINE CAN VOID YOUR WARRANTY.**
- COMMENTS** Address comments or questions regarding this publication to:

**LANDOLL CORPORATION  
1900 NORTH STREET  
MARYSVILLE, KANSAS 66508  
ATTENTION: PUBLICATIONS - DEPT. 55**

## Understanding Safety Statements

You will find various types of safety information on the following pages and on the machine signs (decals) attached to the vehicle. This section explains their meaning.



The Safety Alert Symbol means ATTENTION! YOUR SAFETY IS INVOLVED!

### NOTE

*Means that failure to follow these instructions could cause damage to the equipment or cause it to operate improperly.*

### NOTICE

Special notice - read and thoroughly understand



### CAUTION

Caution means serious equipment or other property damage can occur if instructions on this label are not properly followed.



### WARNING

Warning means serious injury or death can occur if safety measures or instructions on this label are not properly followed.



### DANGER

Danger means a life-threatening situation exists. Death can occur if safety measures or instructions on this label are not properly followed.

### NOTE

*Make sure you read and understand the information contained in this manual and on the machine signs (decals) before you attempt to operate or maintain this vehicle.*

The safety statements contained in this manual relate to the operation of the Model 2410F Weatherproofer 1.

## Decal Safety

1. Examine safety decals and be sure you have the correct safety decals for the implement.
2. Keep these signs clean so they can be observed readily. It is important to keep these decals cleaned more frequently than the implement. Wash with soap and water or a cleaning solution as required.
3. Replace decals that become damaged or lost. Also, be sure that any new implement components installed during repair include decals which are assigned to them by the manufacturer.
4. When applying decals to the implement, be sure to clean the surface to remove any dirt or residue. Where possible, sign placement should protect the sign from abrasion, damage, or obstruction from mud, dirt, oil etc.



### DANGER

- Do not allow anyone to ride on the tractor or implement. Riders could be struck by foreign objects or thrown from the implement.
- Never allow children to operate equipment.
- Keep bystanders away from implement during operation.

## Transporting Safety

### IMPORTANT

**It is the responsibility of the owner/operator to comply with all state and local laws.**

1. When transporting the implement on a road or highway, use adequate warning symbols, reflectors, lights and slow moving vehicle sign as required. Slow moving tractors and towed implements can create a hazard when driven on public roads. They are difficult to see, especially at night.



2. Do not tow an implement that, when fully loaded, weighs more than 1.5 times the weight of the towing vehicle.
3. Carry reflectors or flags to mark the tractor and implement in case of breakdown on the road.

4. Do not transport at speeds over 20 MPH under good conditions. Never travel at a speed which does not allow adequate control of steering and stopping. Reduce speed if towed load is not equipped with brakes
5. Avoid sudden stops or turns because the weight of the implement may cause the operator to lose control of the tractor. Use a tractor heavier than the implement.
6. Use caution when towing behind articulated steering tractors; fast or sharp turns may cause the implement to shift sideways.
7. Keep clear of overhead power lines and other obstructions when transporting. Know the transport height and width of your implement.

## Attaching, Detaching, and Storage

1. Do not stand between the tractor and implement when attaching or detaching implement unless both are not moving.
2. Block implement so it will not roll when unhitched from the tractor.
3. Store in an area where children normally do not play.

## Maintenance Safety

1. Understand the procedure before doing the work. Use proper tools and equipment.
2. Make sure all moving parts have stopped.
3. Do not make adjustments or lubricate implement while it is in motion.
4. Block the implement so it will not roll when working on or under it to prevent injury.

## High Pressure Fluid Safety

1. Escaping fluid under pressure can be nearly invisible and have enough force to penetrate the skin causing serious injury. Use a piece of cardboard, rather than hands, to search for suspected leaks.
2. Any fluid injected into the skin must be surgically removed within a few hours or gangrene may result.
3. Avoid the hazard by relieving pressure before disconnecting hydraulic lines.

## Protective Equipment

1. Wear protective clothing and equipment.
2. Wear clothing and equipment appropriate for the job. Avoid loose fitting clothing.



3. Because prolonged exposure to loud noise can cause hearing impairment or hearing loss, wear suitable hearing protection, such as earmuffs or earplugs.

## Chemical Safety

1. Agricultural chemicals can be dangerous. Improper use can seriously injure persons, animals, plants, soil and property.
2. Read chemical manufacture's instructions and store or dispose of unused chemicals as specified.
3. Handle chemicals with care and avoid inhaling smoke from any type of chemical fire.
4. Store or dispose of unused chemicals as specified by the chemical manufacturer.

## Prepare for Emergencies

1. Keep a First Aid Kit and Fire Extinguisher handy.
2. Keep emergency numbers for doctor, ambulance, hospital and fire department near the phone.

## Tire Safety

1. Tire changing can be dangerous and should be performed by trained personnel using correct tools and equipment.
2. When inflating tires, use a clip-on chuck and extension hose long enough to allow you to stand to one side, not in front of or over the tire assembly. Use a safety cage if available.
3. When removing and installing wheels use wheel-handling equipment adequate for the weight involved.

### Safety Chain

1. Use a chain with a strength rating equal to or greater than the gross weight of towed machinery, which is 10,100 pounds minimum in accordance with ASAE S338.2 specifications. If two or more implements are pulled in tandem, a larger chain may be required. Chain capacity must be greater than the TOTAL weight of all towed implements.
2. A second chain should be used between each implement.
3. Attach the chain to the tractor drawbar support or specified anchor location. Allow only enough slack in the chain to permit turning. The distance from hitch pin to attachment point or intermediate support point should not exceed 9 inches.

Replace the chain if any links or end fittings are broken, stretched or damaged.



## Standard Specifications

### Model Specifications

2410F Weatherproofer 1		
Model Number	2410F-7-24	2410F-9-24
Working Width	14'-0"	18'-0"
Transport Width	14'-8"	14'-8"
Transport Height	12'-1"	13'-7"
Number of Blades F/R	18/20	22/24
Number of Shanks	7	9
Shank Spacing	24"	24"
Spindle Size	4"	4"
Wheel Bolt Pattern	8 Bolt	8 Bolt
Estimated Weight	23,990 lbs.	25,560 lbs.
<b>NOTE: Specifications Are Subject To Change Without Prior Notification</b>		

Tire Inflation			
Tire Size	Tire Manufacturer	Ply/Load Rating	Inflation Pressure (Psi) (Max.)
380/55R-16.5 Imp	Goodyear	8,000 lbs. @ 20 mph	74 psi
440/55R 18	Goodyear	9,650 lbs. @ 30 mph	73 psi

Specific Bolt Torques	
Lug Bolts & Nuts	Torque (FT. LBS.)
3/4-16	250-265 Ft./Lbs.

## General Torque Specifications (rev. 4/97)

**TORQUE SPECIFIED IN FOOT POUNDS** - This chart provides tightening torques for general purpose applications when special torques are not specified on process or drawing. Assembly torques apply to plated nuts and capscrews assembled without supplemental lubrication (as received condition). They do not apply if special graphite moly-disulfide or other extreme pressure lubricants are used. When fasteners are dry (solvent cleaned) add 33% to as received condition torque. Bolt head identification marks indicate grade and may vary from manufacturer to manufacturer. Thick nuts must be used on grade 8 capscrews. Use value in [ ] if using prevailing torque nuts.

UNC SIZE	SAE Grade 2	SAE Grade 5	SAE Grade 8	UNF SIZE	SAE Grade 2	SAE Grade 5	SAE Grade 8
1/4-20	4 [5]	6 [7]	9 [11]	1/4-28	5 [6]	7 [9]	10 [12]
5/16-18	8 [10]	13 [13]	18 [22]	5/16-24	9 [11]	14 [17]	20 [25]
3/8-16	15 [19]	23 [29]	35 [42]	3/8-24	17 [21]	25 [31]	35 [44]
7/16-14	24 [30]	35 [43]	55 [62]	7/16-20	27 [34]	40 [50]	60 [75]
1/2-13	35 [43]	55 [62]	80 [100]	1/2-20	40 [50]	65 [81]	90 [112]
9/16-12	55 [62]	80 [100]	110 [137]	9/16-18	60 [75]	90 [112]	130 [162]
5/8-11	75 [94]	110 [137]	170 [212]	5/8-18	85 [106]	130 [162]	180 [225]
3/4-10	130 [162]	200 [250]	280 [350]	3/4-16	150 [188]	220 [275]	320 [400]
7/8-9	125 [156]	320 [400]	460 [575]	7/8-14	140 [175]	360 [450]	500 [625]
1-8	190 [237]	408 [506]	680 [850]	1-14	210 [263]	540 [675]	760 [950]
1-1/8-7	270 [337]	600 [750]	960 [1200]	1-1/8-12	300 [375]	660 [825]	1080 [1350]
1-1/4-7	380 [475]	840 [1050]	1426 [1782]	1-1/4-12	420 [525]	920 [1150]	1500 [1875]
1-3/8-6	490 [612]	1010 [1375]	1780 [2225]	1-3/8-12	560 [700]	1260 [1575]	2010 [2512]
1-1/2-6	650 [812]	1460 [1825]	2360 [2950]	1-1/2-12	730 [912]	1640 [2050]	2660 [3325]
1-3/4-5	736 [920]	1651 [2063]	2678 [3347]	1-3/4-12	920 [1150]	2063 [2579]	3347 [4183]

**METRIC:**

Coarse thread metric class 10.9 fasteners and class 10.0 nuts and through hardened flat washers, phosphate coated, Rockwell "C" 38-45. Use value in [ ] if using prevailing torque nuts.

Nominal thread diameter (mm)	Newton Meters (Standard Torque)	Foot Pounds (Standard Torque)	Nominal Thread Diameter (mm)	Newton Meters (Standard Torque)	Foot Pounds (Standard Torque)
6	10 [14]	7 [10]	20	385 [450]	290 [335]
7	16 [22]	12 [16]	24	670 [775]	500 [625]
8	23 [32]	17 [24]	27	980 [1105]	730 [825]
10	46 [60]	34 [47]	30	1330 [1470]	990 [1090]
12	80 [125]	60 [75]	33	1790 [1950]	1340 [1450]
14	125 [155]	90 [115]	36	2325 [2515]	1730 [1870]
16	200 [240]	150 [180]	39	3010 [3210]	2240 [2380]
18	275 [330]	205 [245]			

Table 2-1: General Torque Specifications

# Hydraulic Fitting Torque Specifications

**TORQUE IS SPECIFIED IN FOOT POUNDS- 37° JIC, ORS, & ORB (REV. 10/97)**

This chart provides tightening torques for general purpose applications when special torques are not specified on process or drawing. Assembly torques apply to plated nuts and capscrews assembled without supplemental lubrication (as received condition). They do not apply if special graphite moly-disulfide or other extreme pressure lubricants are used. When fasteners are dry (solvent cleaned) add 33% to as received condition torque. Bolt head identification marks indicate grade and may vary from manufacturer to manufacturer. Thick nuts must be used on grade 8 capscrews. Use value in [ ] if using prevailing torque nuts.

<b>Parker Brand Fittings</b>			
<b>Dash Size</b>	<b>37 Degree JIC</b>	<b>O-Ring (ORS)</b>	<b>O-Ring Boss (ORB)</b>
-4	11-13	15-17	13-15
-5	14-16	-----	21-23
-6	20-22	34-36	25-29
-8	43-47	58-62	40-44
-10	55-65	100-110	58-62
-12	80-90	134-146	75-85
-16	115-125	202-218	109-121
-20	160-180	248-272	213-237
-24	185-215	303-327	238-262
-32	250-290	-----	310-340
<b>Gates Brand Fittings</b>			
<b>Dash Size</b>	<b>37 Degree JIC</b>	<b>O-Ring (ORS)</b>	<b>O-Ring Boss (ORB)</b>
-4	10-11	10-12	14-16
-5	13-15	-----	-----
-6	17-19	18-20	24-26
-8	34-38	32-40	37-44
-10	50-56	46-56	50-60
-12	70-78	65-80	75-83
-14	-----	65-80	-----
-16	94-104	92-105	111-125
-20	124-138	125-140	133-152
-24	156-173	150-180	156-184
-32	219-243	-----	-----
<b>Aeroquip Brand Fittings</b>			
<b>Dash Size</b>	<b>37 Degree JIC</b>	<b>O-Ring (ORS)</b>	<b>O-Ring Boss (ORB)</b>
-4	11-12	10-12	14-16
-5	15-16	-----	16-20
-6	18-20	18-20	24-26
-8	38-42	32-35	50-60
-10	57-62	46-50	75-80
-12	79-87	65-70	125-135
-14	-----	-----	160-180
-16	108-113	92-100	200-220
-20	127-133	125-140	210-280
-24	158-167	150-165	270-360
-32	245-258	-----	-----

Table 2-2: Hydraulic Fitting Torque Specifications

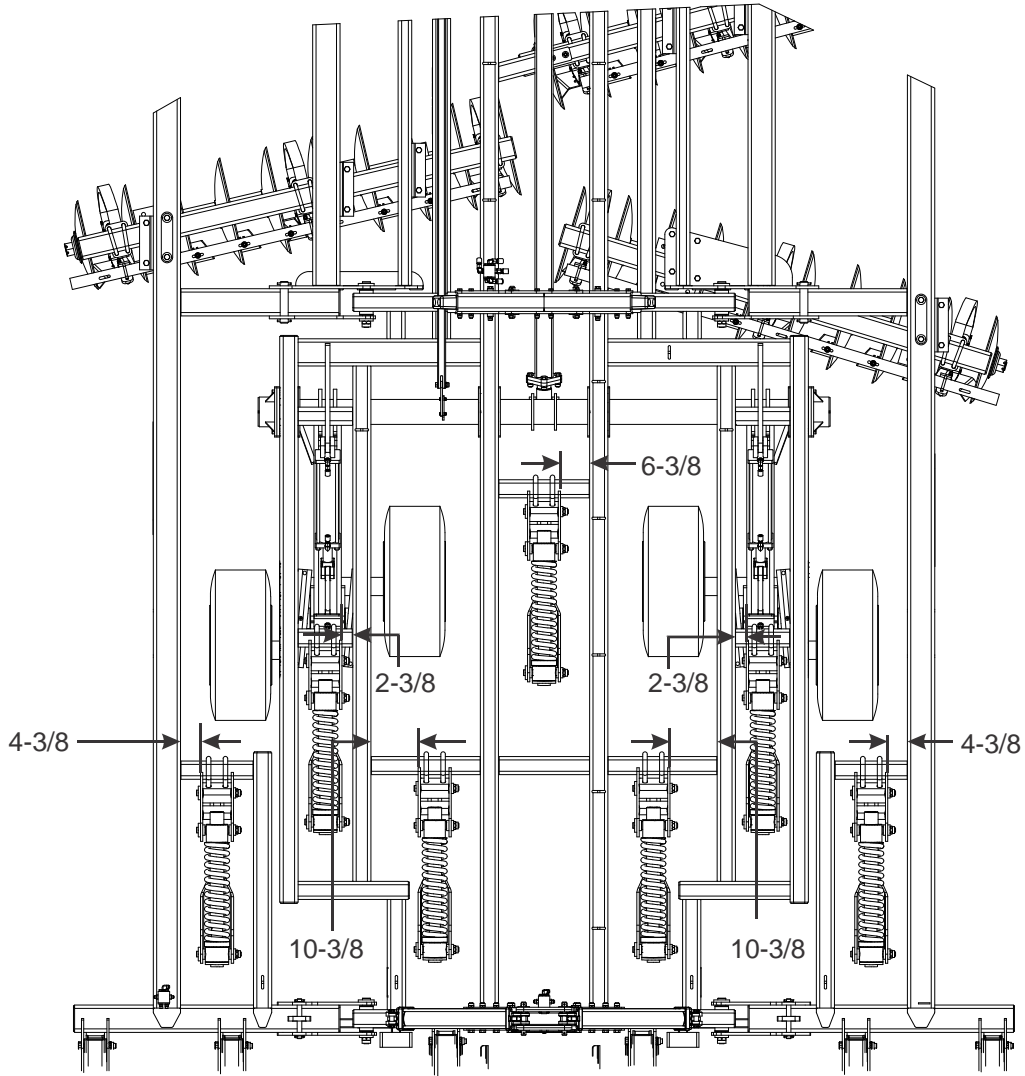

2410f-7-24 shank placement

Figure 2-1: Shank Placement Assembly (2410F-7-24)

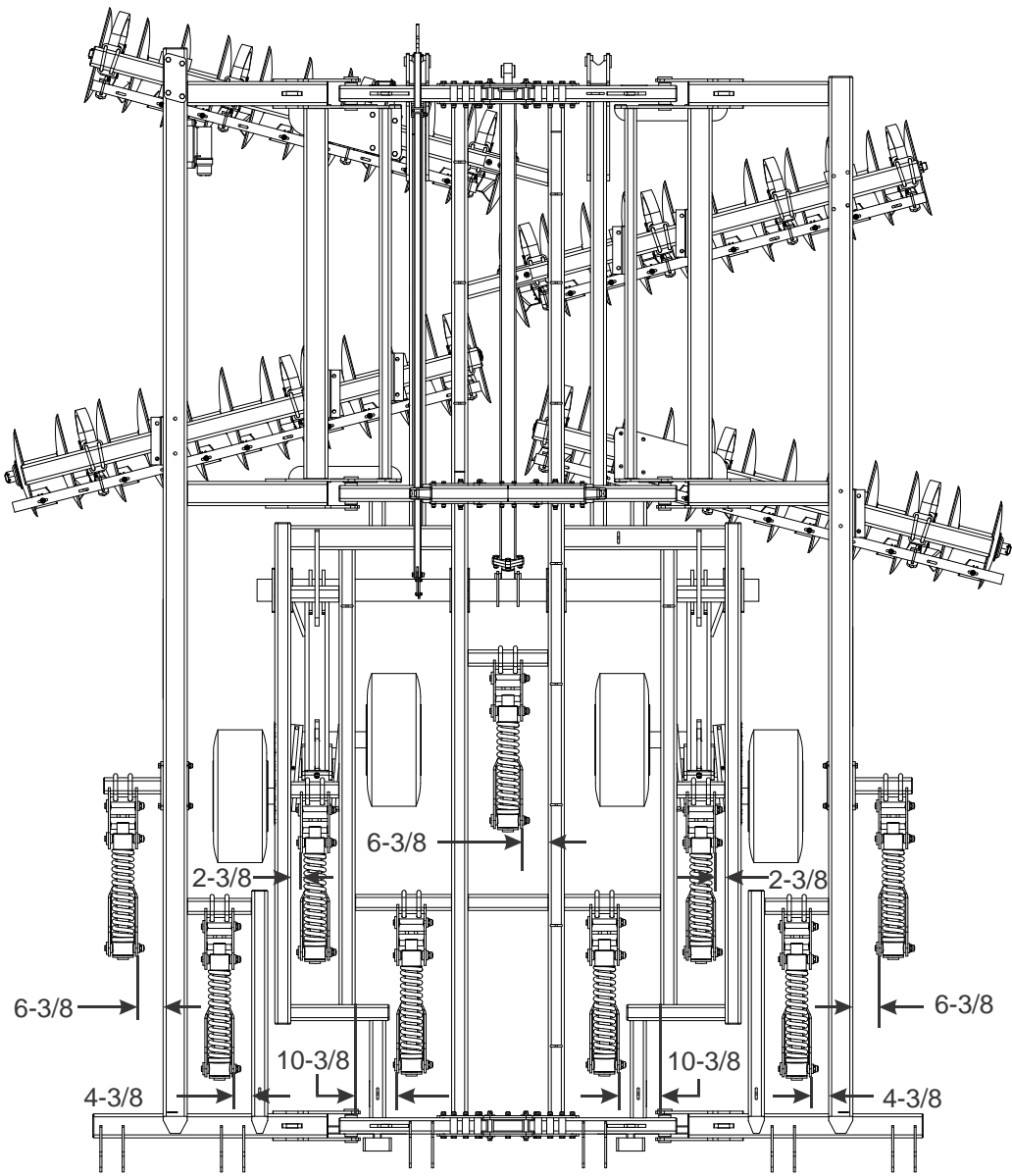

2410-9-24 shank placement

Figure 2-2: Shank Placement Assembly (2410F-9-24)

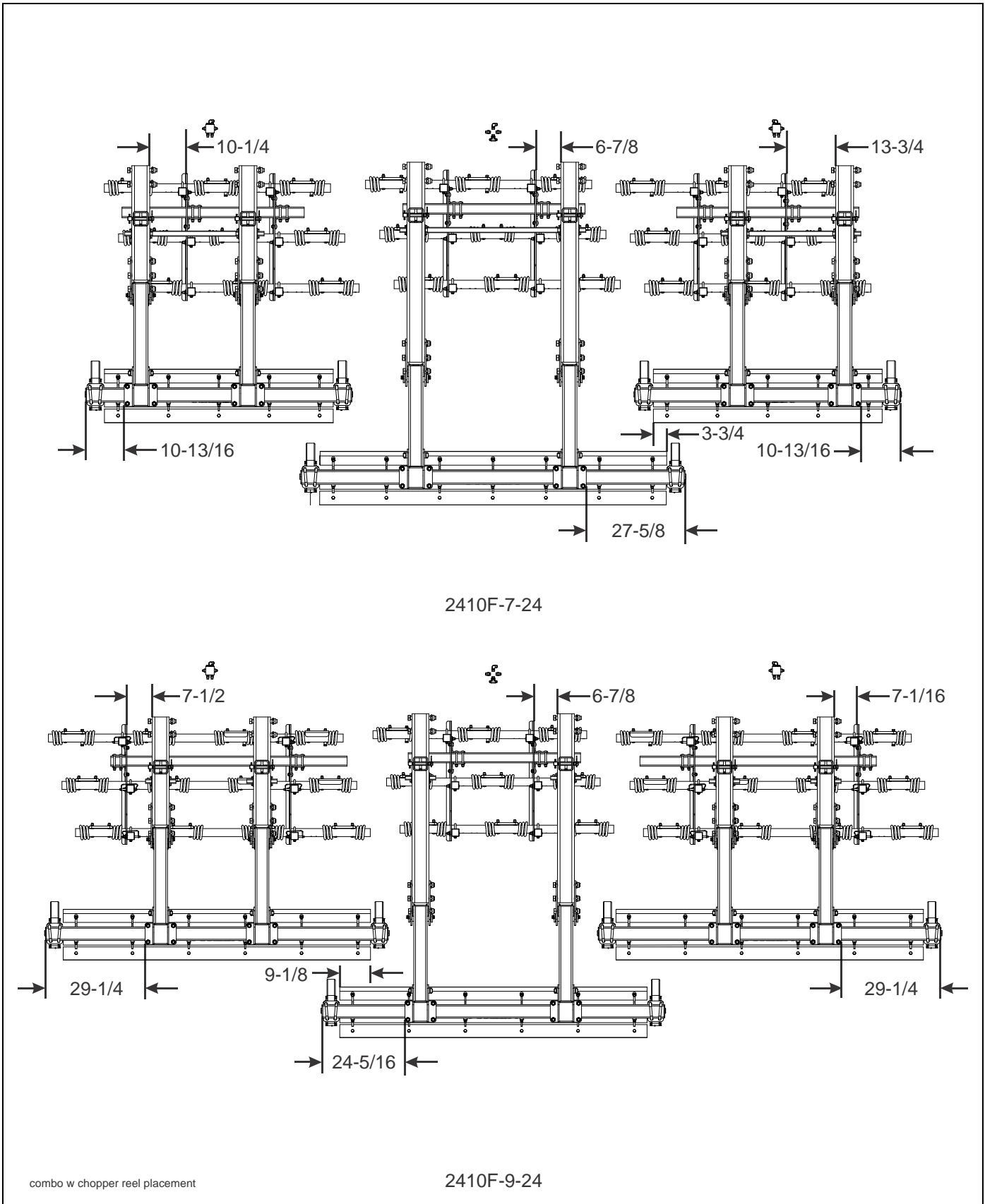
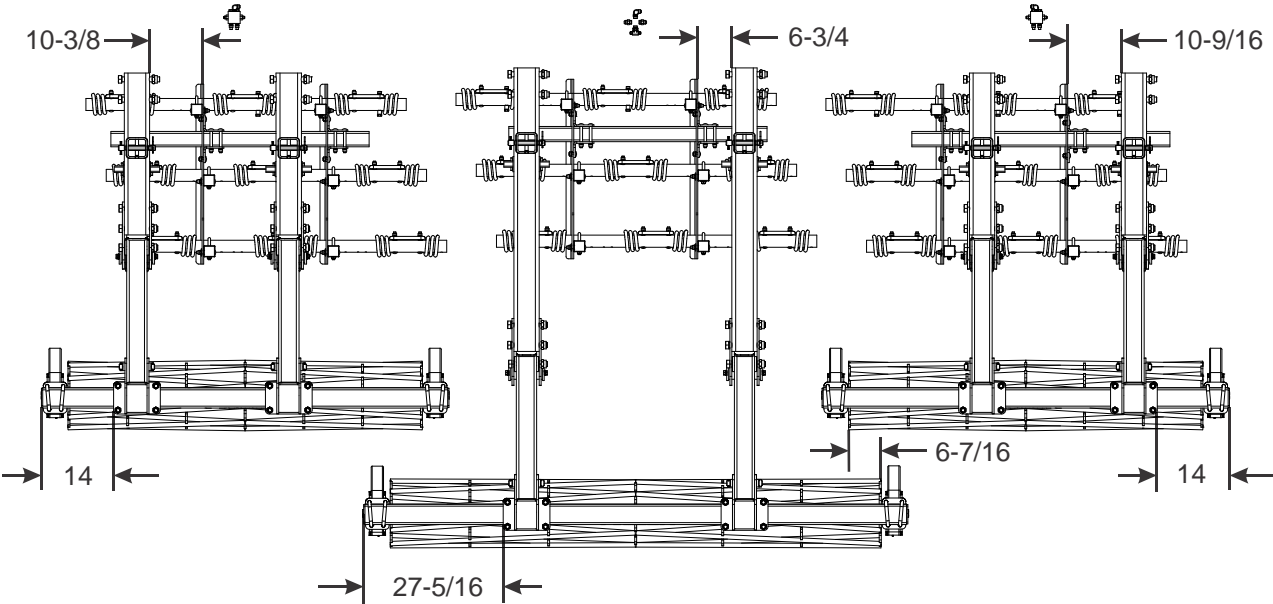
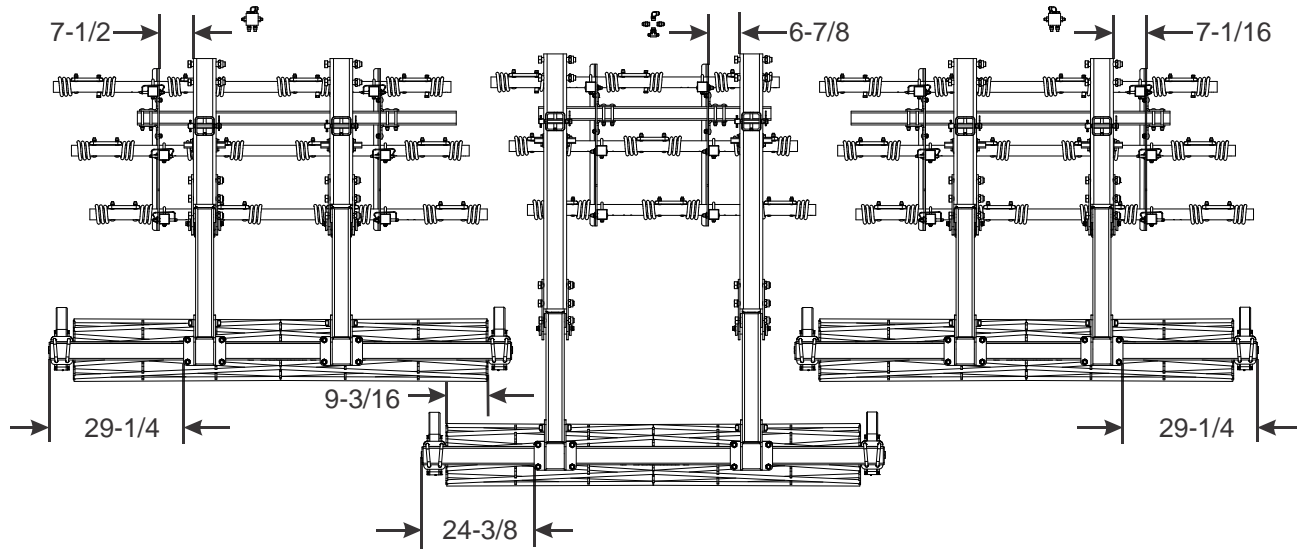

Figure 2-3: Finishing Combo w/ Chopper Reel Installation



2410F-7-24



combo w conditioner reel placement

2410F-9-24

Figure 2-4: Finishing Combo w/ Conditioner Reel Installation

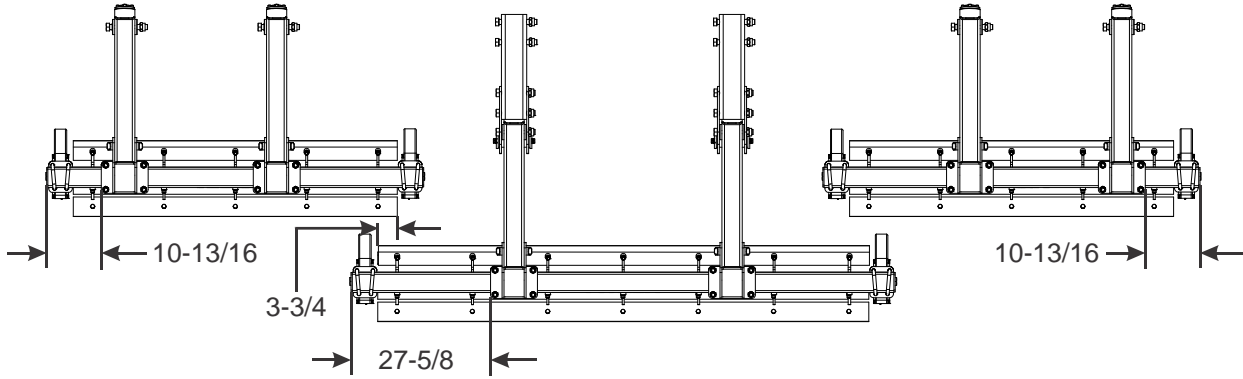

2410F-7-24

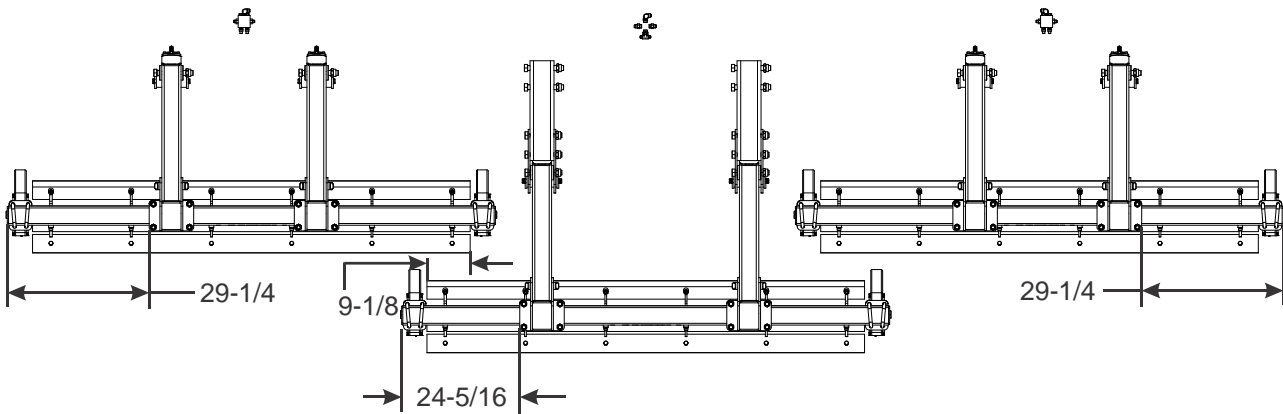

chopper reel placement

2410F-9-24

Figure 2-5: Finishing Chopper Reel Installation



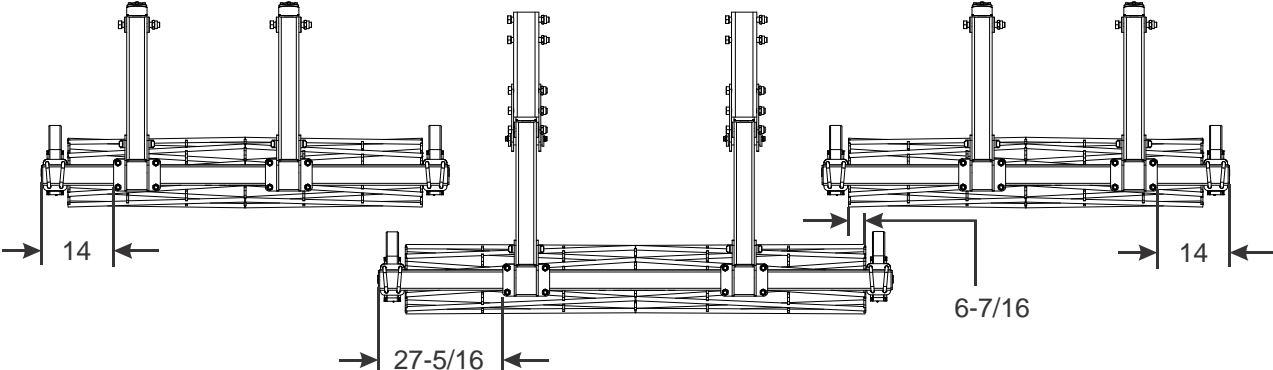

2410F-7-24

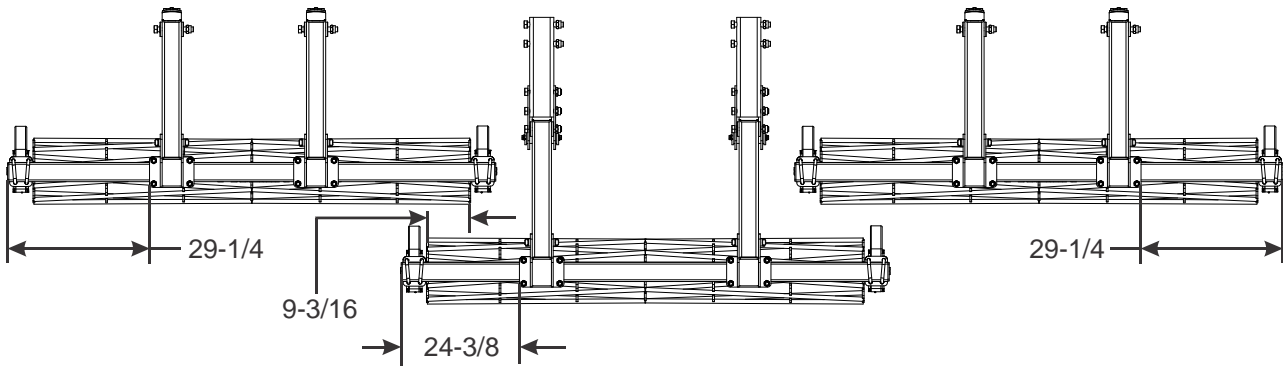

conditioner reel placement

2410F-9-24

Figure 2-6: Finishing Conditioner Reel Installation

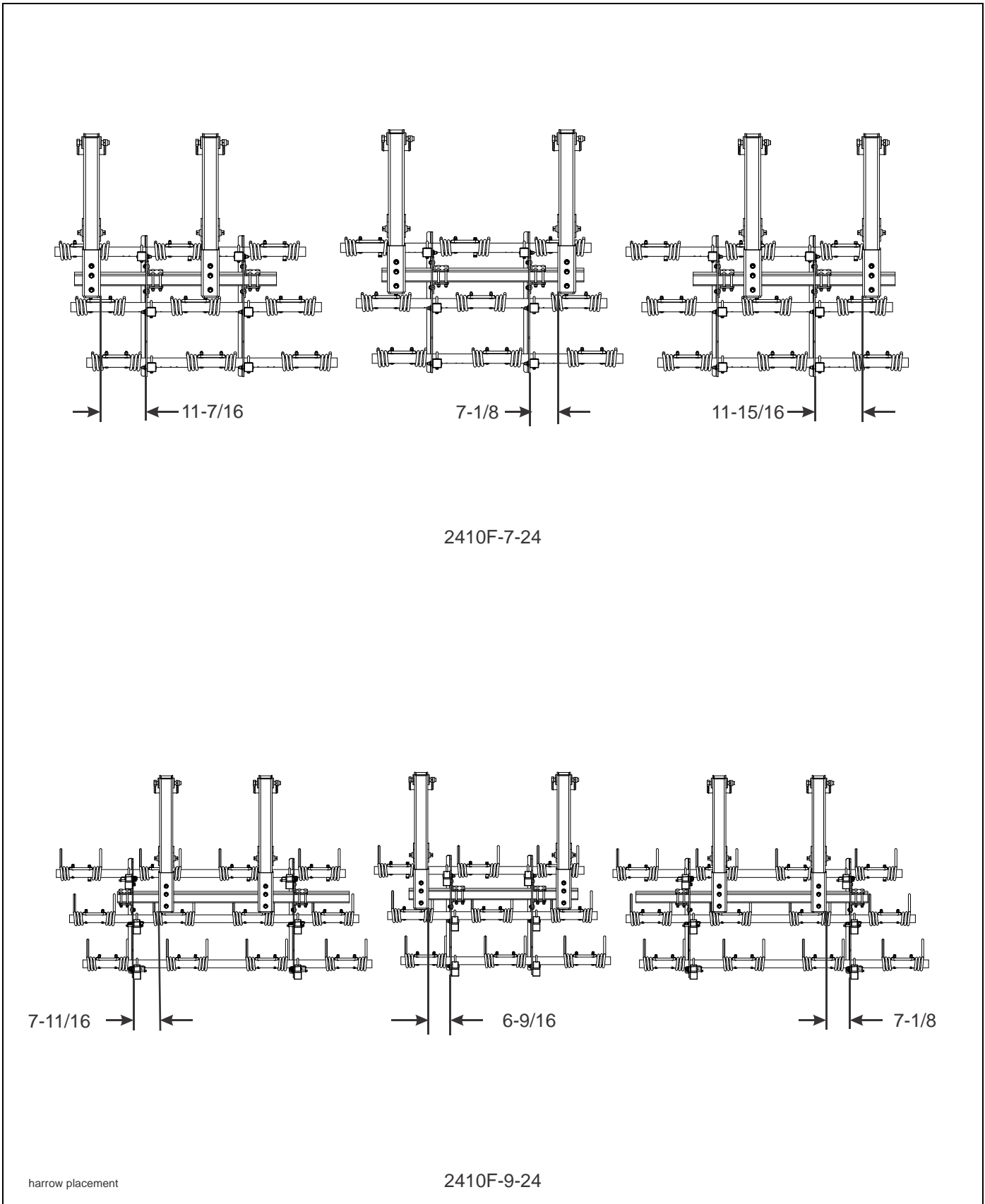

Figure 2-7: Finishing Harrow Installation

## Assembly Instructions

It is very important that your new 2410F Weatherproofer I be properly assembled, adjusted and lubricated before use. Illustrations to assist with the assembly process are provided in “**Standard Specifications**” on page 2-1. They show proper shank and light mounting bracket spacing. Illustrations in this section show proper assembly procedures. Remove paint from grease fittings. Replace any grease fittings that are damaged or missing. Be sure to return screws, clips, etc., to their original locations.

To insure alignment of assemblies, **leave the nuts loose until completion** of final assembly. Use lock washers or flat washers as specified. Spread all cotter pins.

**After completion of final assembly, tighten all nuts evenly** to prevent misalignment, distortion or binding.

Tighten all screws and nuts to the recommended torques shown in **Table 2-1**.



### DANGER

**Disc blades are extremely sharp. Exercise extreme care when working on or near disc blades. Do not allow disc to roll over or fall onto any body part. Do not allow wrenches to slip when working near disc blades. Never push wrenches toward disc blades. Do not climb over machine above disc blades. Failure to stay clear of disc blade edges can cause serious personal injury or death.**



### WARNING

**Do not attempt to lift heavy parts (such as the frame, disc gangs, wheel lift, and pull hitch) manually. Use a hoist or a forklift to move these parts into position.**



### DANGER

**To prevent accidental lowering:**

- 1. All hydraulically elevated equipment must be locked out using the cylinder lockouts.**
- 2. Lower equipment to the ground while servicing or when it is idle.**

**Failure to take measures to prevent accidental lowering may result in serious personal injury or death.**



### CAUTION

**Be sure to bleed the hydraulic system of all air in lines after installation. Failure to bleed the system of all air can result in improper machine operation.**

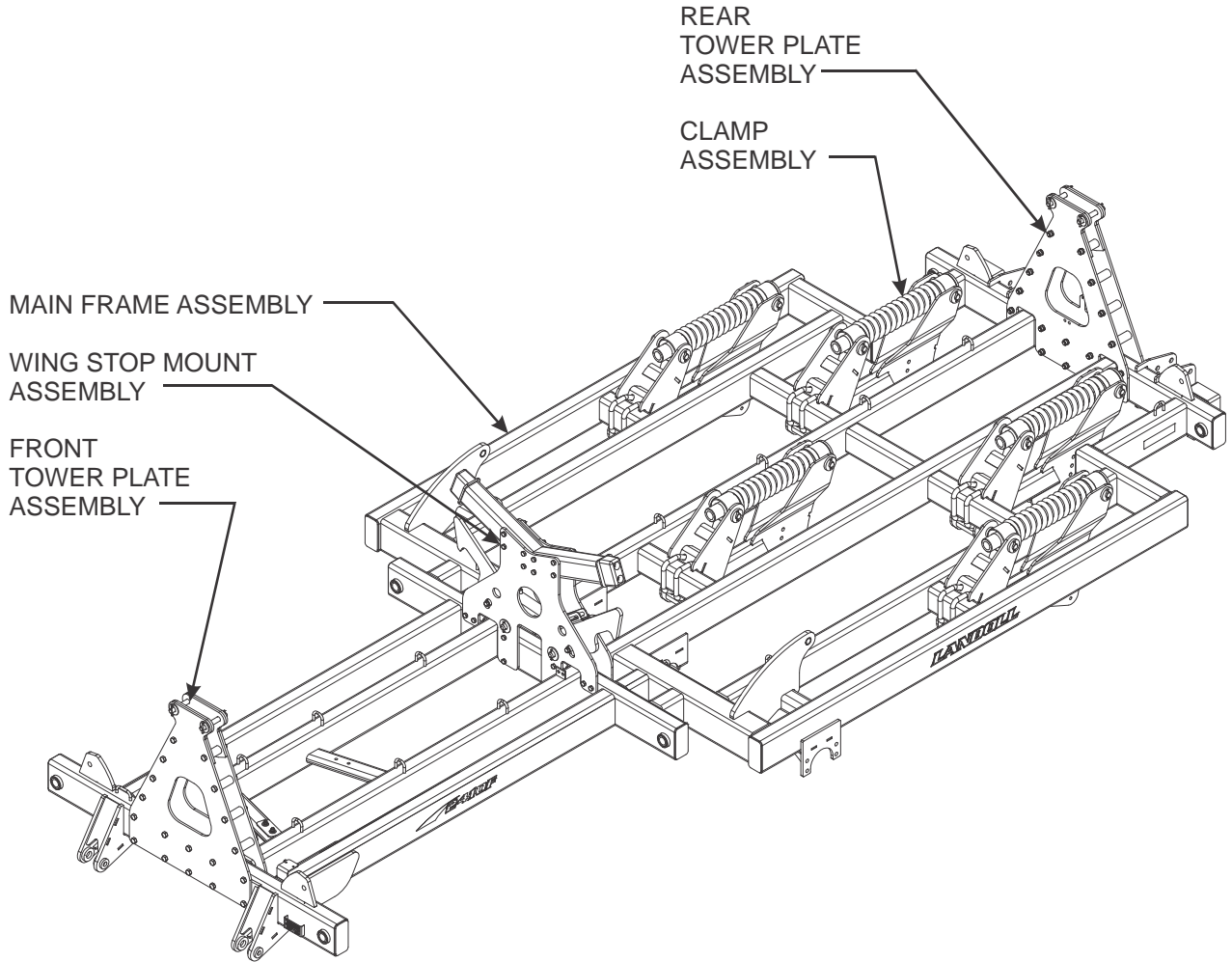

m2410f-9-24 main frame assy op

**Figure 3-1: Frame Assembly**

## Weatherproofer I Frame Assembly

**IMPORTANT**

Read all safety precautions at the front of the section before attempting any of the following procedures.



**WARNING**

Do not attempt to lift heavy parts (such as the frame, disc gangs, wheel lift, and pull hitch) manually. Use a hoist or a forklift to move these parts into position.

1. Place frame assembly on stands approximately 36" high. The assembly area should be a large level area of sufficient size to accommodate the Weatherproofer I when fully assembled (**See Figure 3-1.**)
2. The front and rear tower plate, wing stop mount, and clamp assemblies are installed at the factory.

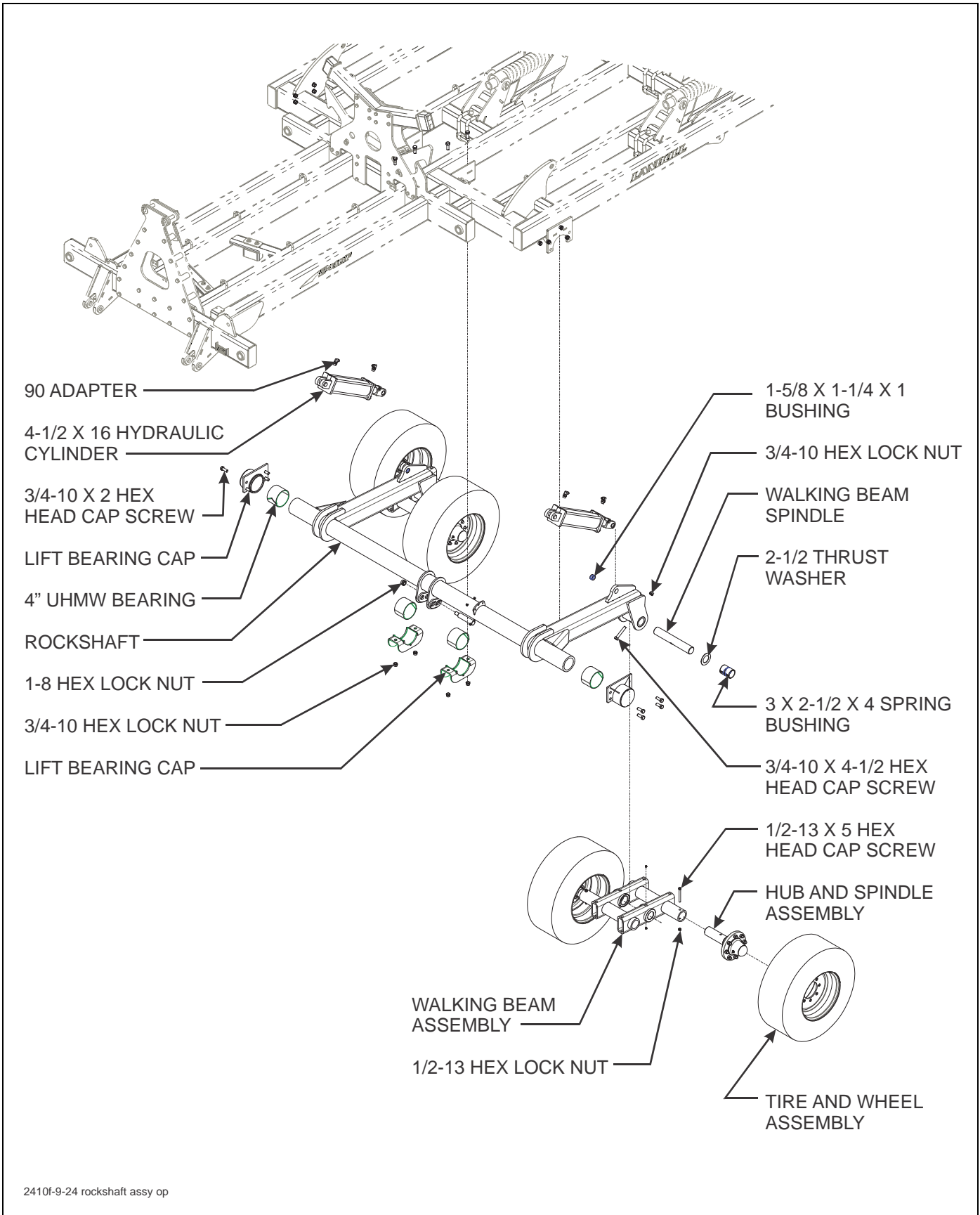

**Figure 3-2: Wheel Lift Installation**

## Wheel Lift Installation

1. Place 4" UHMW bearings onto rockshaft. Attach lift bearing caps onto rockshafts using 3/4-10 x 2 hex head cap screws and hex lock nuts.
2. Attach rockshaft to the frame assembly using lift bearing cap, 3/4-10 x 2 hex head cap screws, and hex lock nuts.
3. Attach base end of each 4-1/2 x 16 hydraulic cylinder to the main frame using lift pins and 5/16 x 2-1/2 spring slotted pins which are included with the cylinder (**See Figure 3-2.**)
4. Attach rod end of each 4-1/2 x 16 hydraulic cylinder to the lift using lift pins and 5/16 x 2-1/2 spring slotted pins which are included with the cylinder (**See Figure 3-2.**)
5. Install 90° adapters in each port of both 4-1/2 x 16 hydraulic cylinders.

### **IMPORTANT**

**Do not use 90° adapters with restrictors in ports of lift hydraulic cylinders.**

6. At this point, the lift cylinders need to be fully retracted on both sides before the radius rod is installed.
7. Assemble the wheels and tires to the hubs. Tighten wheel bolts evenly to assure proper wheel alignment. Wheel bolts should be tightened to 90 ft-lbs. of torque. The hoist can then be removed.
8. Inflate the tire as recommended by the manufacturer.

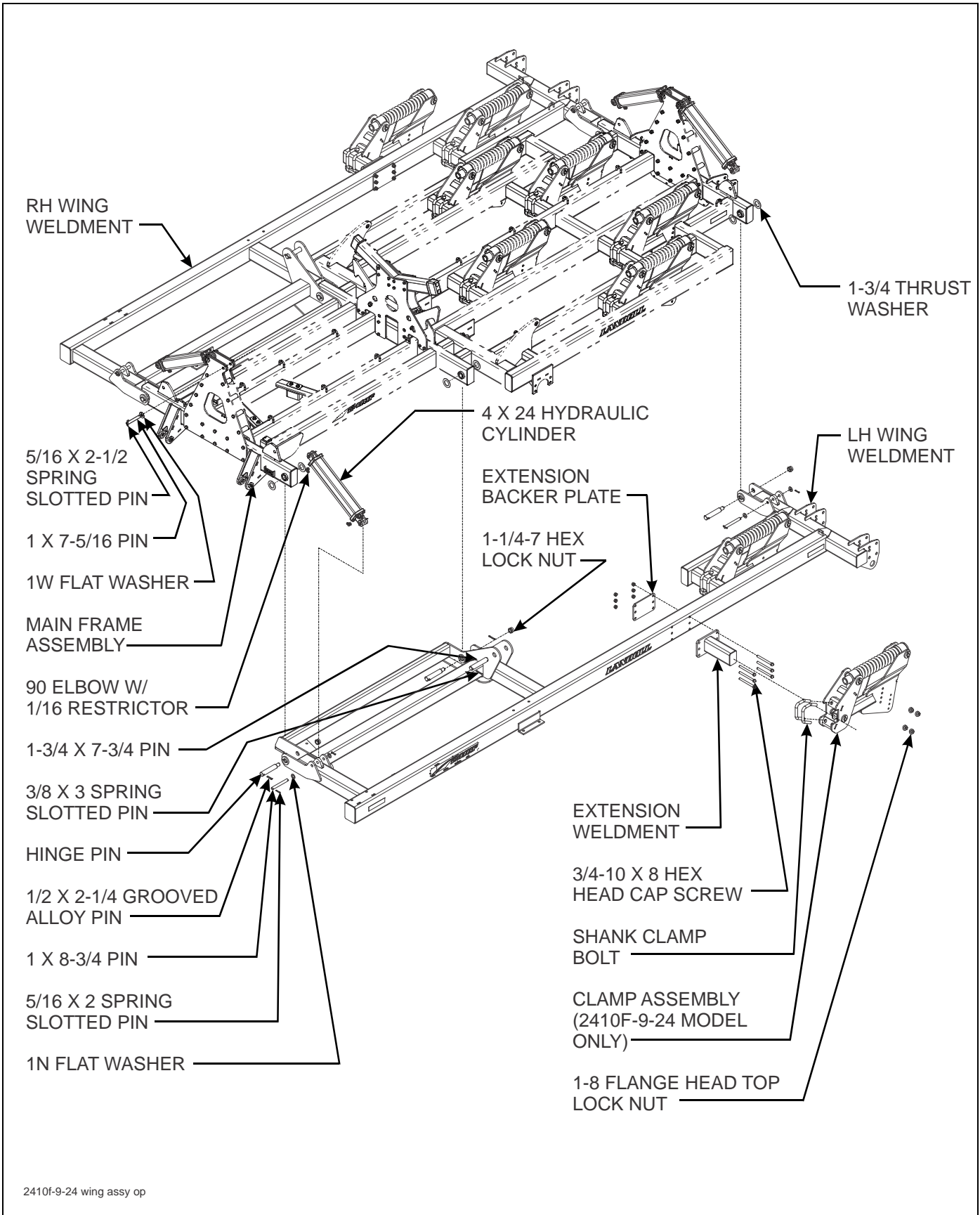

Figure 3-3: Wing and Extension Assembly



## Weatherproofer I Wing and Extension Installation

### IMPORTANT

Read all safety precautions at the front of the section before attempting any of the following procedures.



### WARNING

Do not attempt to lift heavy parts (such as the frame, disc gangs, wheel lift, and pull hitch) manually. Use a hoist or a forklift to move these parts into position.

1. Assemble RH and LH wing weldments to the main frame assembly using hinge pin, 1-3/4 thrust washer, 1/2 x 2-1/4 grooved alloy pin, and 1-1/4 - 7 hex lock nut (See Figure 3-3.)

### NOTE

*Thrust washers are located in between hinge ear plates of wing.*

2. Position the 1-3/4 X 7-3/4 pin into the holes of the wing frame lock plates. Secure it with (2) 3/8 X 3 spring slotted pins.
3. Connect base end of each 4 x 24 wing fold hydraulic cylinder to the top of the front and rear tower plate assembly with ports facing downward using 1 x 7-5/16 pin, 1W" washer, and spring slotted pin.
4. Connect rod end of each 4 x 24 hydraulic cylinder to wing through holes in the hinge fold plates using 1 x 8-3/4 pin, 1"N flat washer, and 5/16 x 2 spring slotted pin.
5. On 2410F-9-24 model only, attach extension weldment to RH and LH wing assemblies using 3/4-10 x 8 hex head cap screws, extension backer plate, and hex lock nuts.
6. Add shank clamp assemblies to extension weldments using shank clamp bolt and 1-8 flange head top lock nut. See Figures 2-1 and 2-2 for shank placement dimensions.
7. Tighten all hardware to the recommended torques shown in Table 2-1.

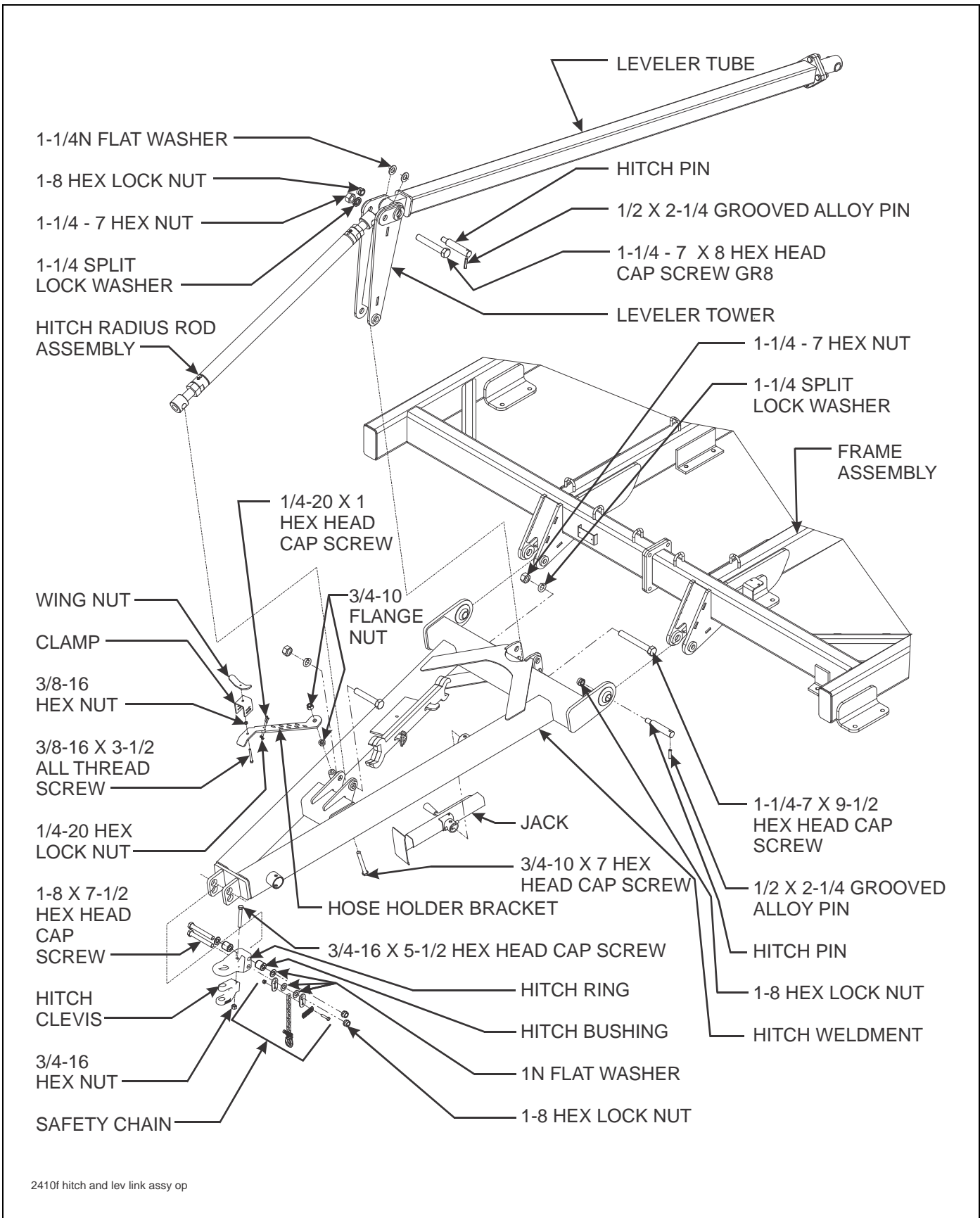

2410f hitch and lev link assy op

**Figure 3-4: Hitch Installation**

## Hitch Installation

1. Attach the hitch weldment to the front of the frame using hitch pins, 1-8 hex lock nuts, and 1/2 x 2-1/4 grooved alloy pins (**See Figure 3-4.**)
2. Move the jack to the forward mounting tube and rotate to parking position to support the front of the hitch.
3. Insert a 3/4-10 x 7 hex head cap screw into the hose holder tube on the right side of the hitch from the bottom side so the threads point upward. Hold in place with a 3/4 prevailing torque flange nut with the flange facing upward as well. Do not tighten this cap screw, so the hose holder bracket may pivot freely in this joint.
4. Slide the hose holder bracket over the screw and secure with another 3/4 prevailing torque flange nut.
5. Install a 3/8-16 x 3-1/2 all-thread screw in the front of the hose holder bracket and secure with a 3/8-16 hex nut.
6. Slide the hose holder clamp over the 3/8" screw and loosely start the wing nut on top of the clamp. Hydraulic hoses will be routed through the clamp after assembly.

### **IMPORTANT**

**The clamp has two sides, so that extend hoses can be located on one side and retract hoses can be located on the other side for reference.**

### **IMPORTANT**

**The leveler tower must be installed so that the narrow end of the tower is down and the reinforced holes are to the rear of the machine.**

7. Connect narrow end of the leveler tower to the bottom hole of the hitch weldment using 1-1/4-7 x 9-1/2 hex head cap screw, split lock washer, and hex nut.
8. Connect front end of leveler tube to the rear top hole of the leveler tower using hitch pin, 1-1/4 flat washers, 1-8 hex lock nut, and 1/2 x 2-1/4 grooved alloy pin.
9. Connect rear end of leveler tube to the bottom/rear hole of the rockshaft assembly using hitch pin, 1-1/4 flat washers, 1-8 hex lock nut, and 1/2 x 2-1/4 grooved alloy pin.
10. Attach the hitch radius rod assembly to the top front hole of the leveler tower using 1-1/4-7 x 8 hex head cap screw, split lock washer, and hex nut.
11. Connect the remaining end of the hitch radius rod assembly to the hitch weldment using 1-1/4-7 x 8 hex head cap screw, split lock washer, and hex nut.
12. Adjust the radius rod assembly to be approximately 62-3/4" pin to pin in length. This will result in the machine being level in the field for drawbars about 18" above the ground and provide adequate ground clearance for folding the wings initially.
13. Attach hitch clevis to the hitch ring using 3/4-16 x 5-1/2 hex head cap screw and hex nut (as required).
14. Assemble hitch clevis assembly to the hitch weldment using 1-8 x 7-1/2 hex head cap screws, hitch bushings, flat washers, and hex lock nuts through the top hole. Use 1-8 x 7-1/2 hex head cap screw, safety chain assembly, flat washer, and hex lock nut in the lower hole.

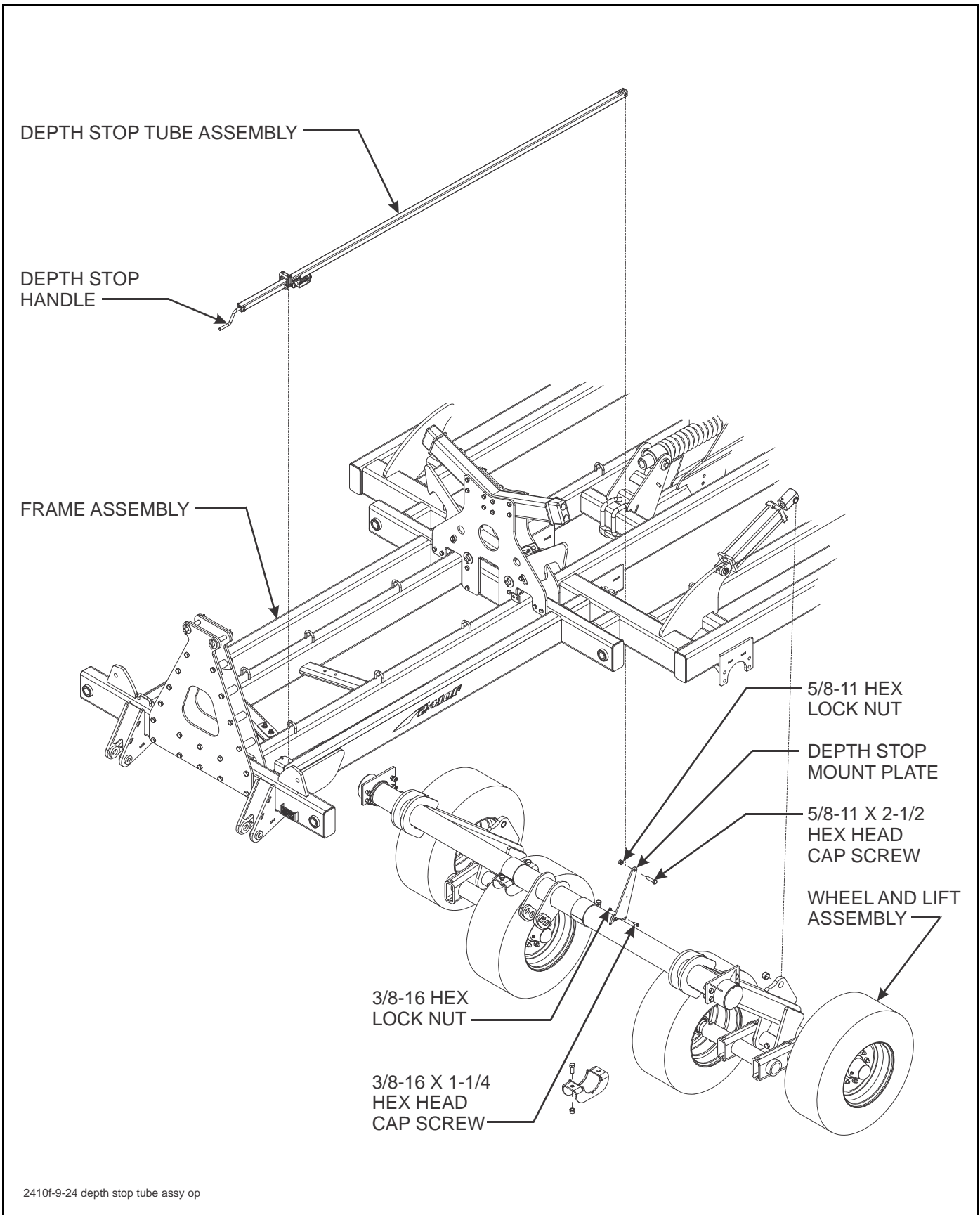

Figure 3-5: Depth Stop Assembly Installation

## Depth Stop Tube Assembly

1. Attach the depth stop mount plate to the lift using 3/8-16 x 1-1/4 hex head cap screws and hex lock nuts.
2. Lay the depth stop tube assembly on top of the center frame. Insert a 5/8-11 x 2-1/2 hex head cap screw in the rear hole of the tube assembly from the left side (**See Figure 3-5.**) Insert the screw through the depth stop mounting plate on the center lift and secure with a 5/8-11 hex lock nut.

### **IMPORTANT**

**It may be necessary to leave these screws loose to attach the valve hoses later.**

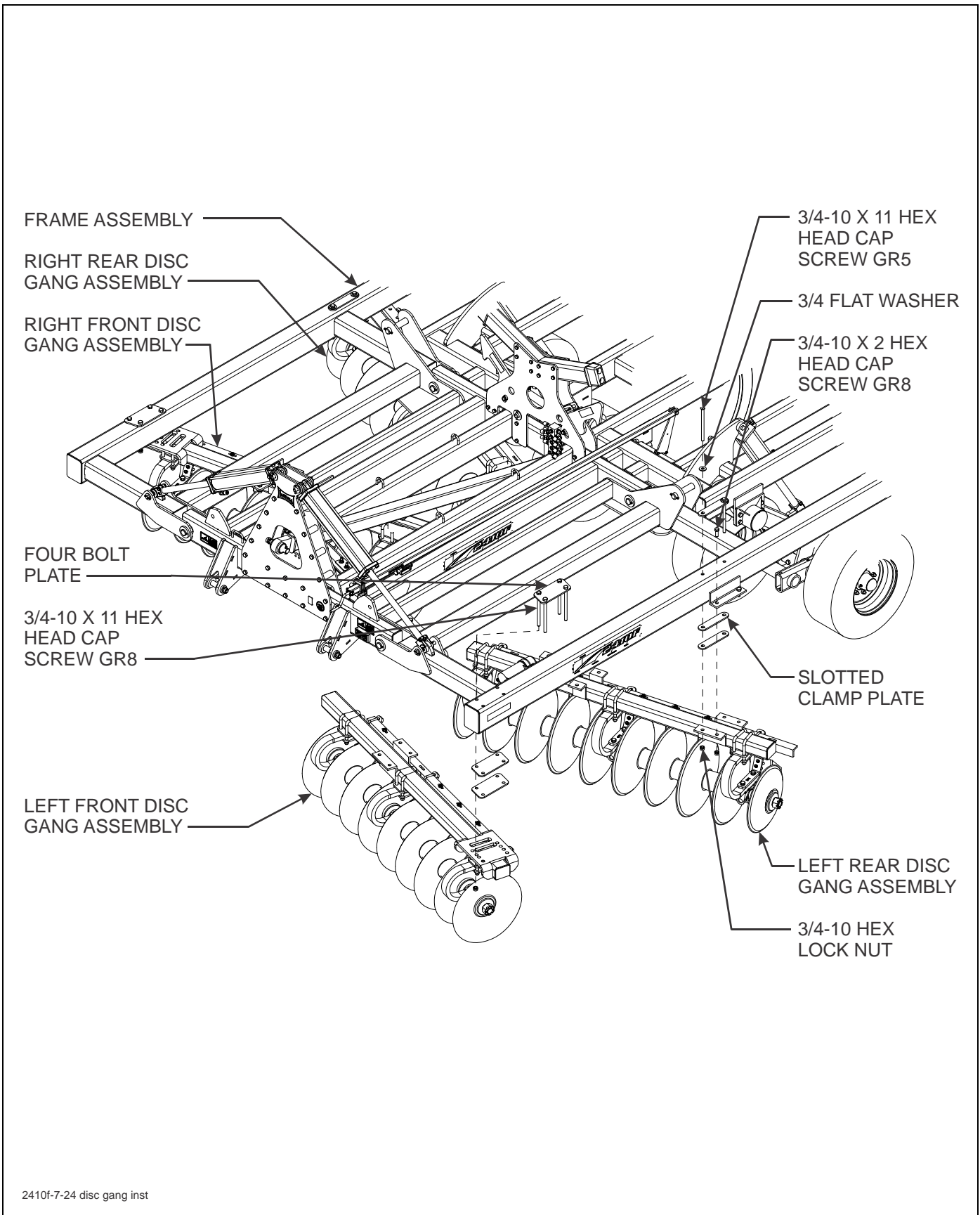

Figure 3-6: Disc Gang Installation - Wing Frame (2410F-7-24)

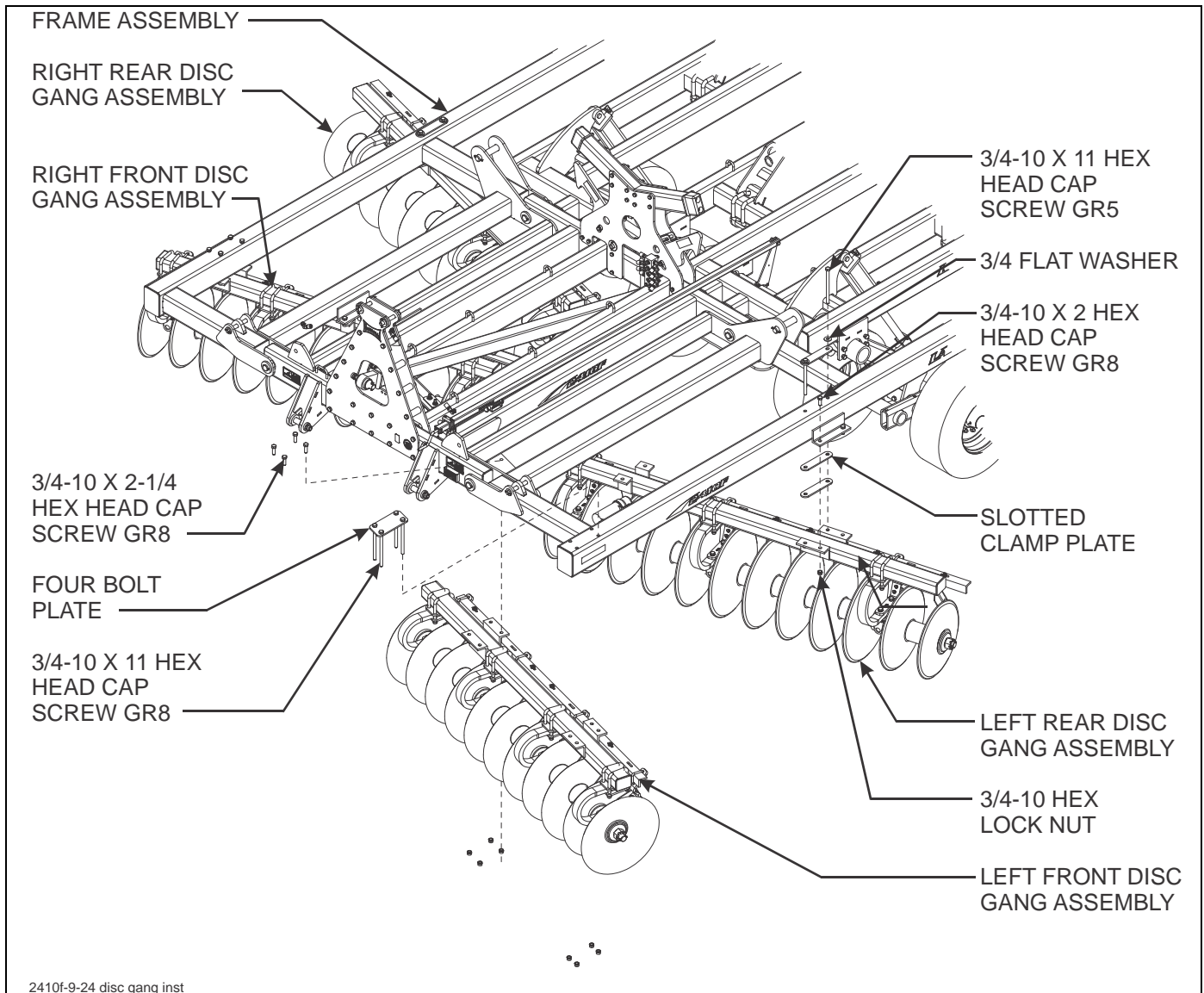

Figure 3-7: Disc Gang Installation - Wing Frame (2410F-9-24)

## Disc Gang Installation - Wing Frame



### DANGER

Disc blades are extremely sharp. Exercise extreme care when working on or near disc blades. Do not allow disc to roll over or fall onto any body part. Do not allow wrenches to slip when working near disc blades. Never push wrenches toward disc blades. Do not climb over machine above disc blades. Failure to stay clear of disc blade edges can cause serious personal injury or death.

1. Assemble the disc gang assemblies to the wing frames using clamp plates, four bolt plates, 3/4-10 x 2 grade 8 hex head cap screws, 3/4-10 x 2-1/4 grade 8 hex head cap screws, 3/4-10 x 10 grade 5 hex head cap screws (2410F-7 models), 3/4-10 x 11 grade 5 hex head cap screws (2410F-7 and 2410F-9 models), 3/4 flat washers, and hex lock nuts (See Figures 3-6 and 3-7)

# ASSEMBLY INSTRUCTIONS

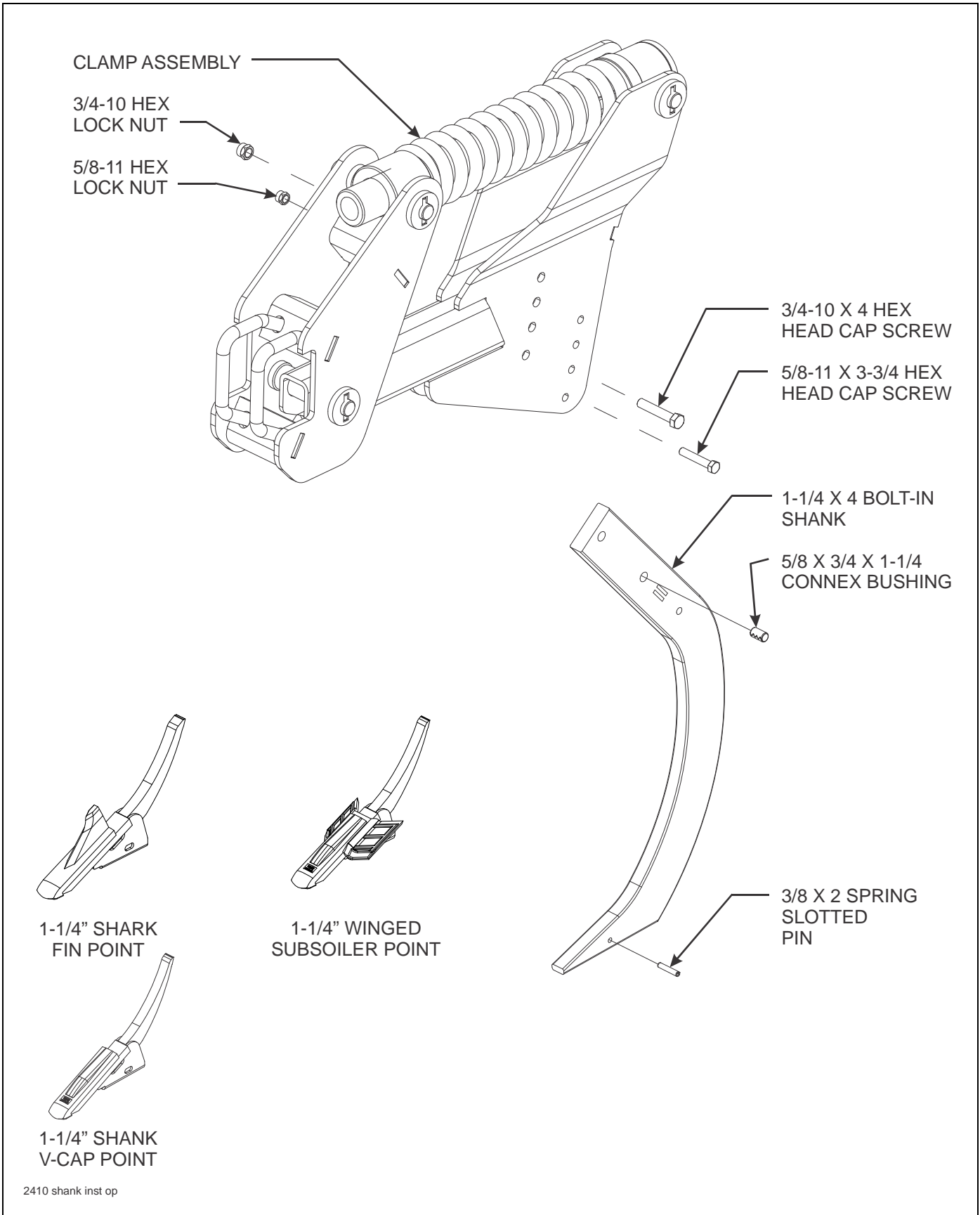
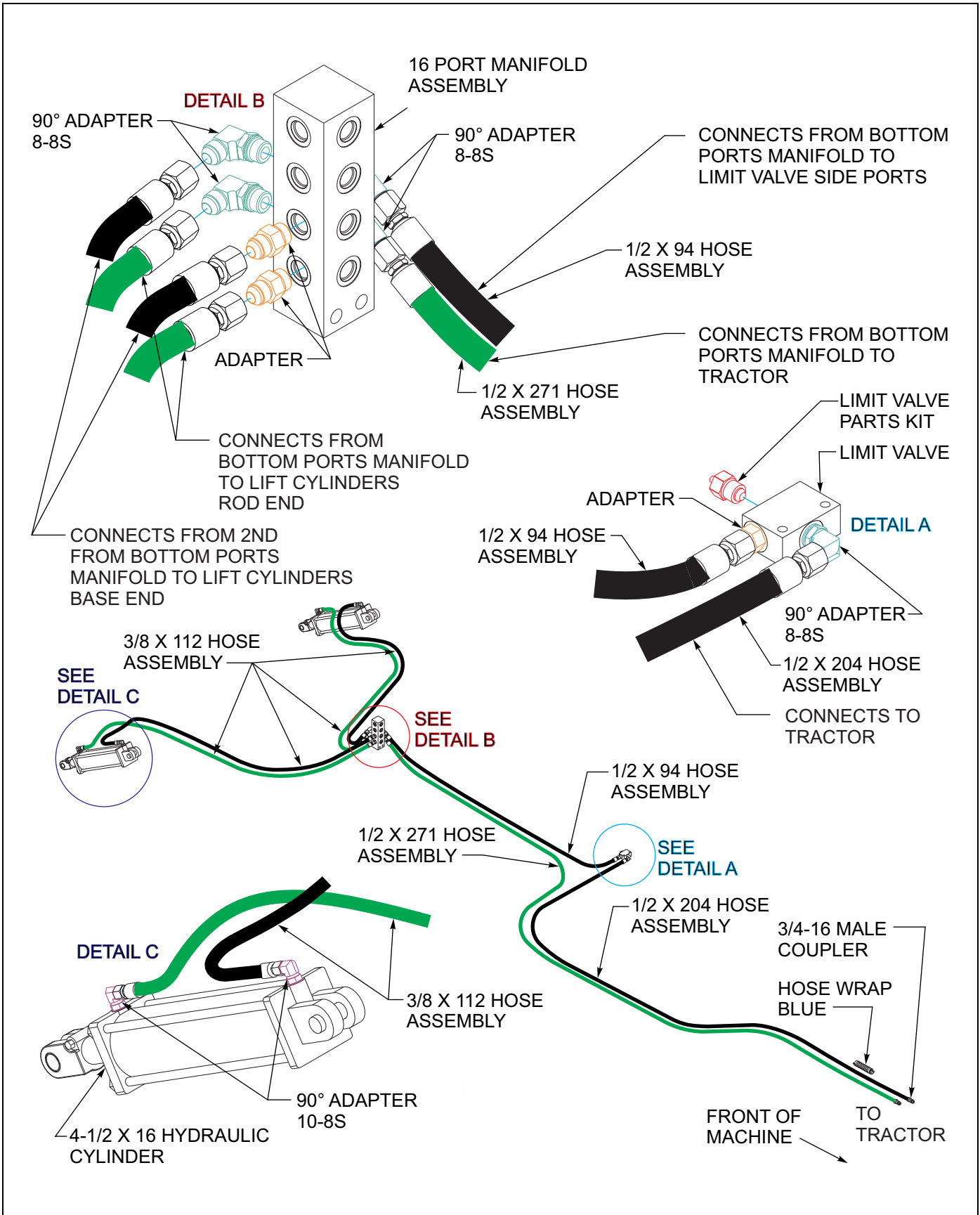

Figure 3-8: Auto Reset Shank and Point Installation



## Auto Reset Shank and Point Installation

1. Attach each 1-1/4 x 4 bolt-in shank to each clamp assembly using 3/4-10 x 4 hex head cap screw and hex lock nut in the top hole and 5/8-11 x 3-3/4 hex head cap screw, 5/8 x 3/4 x 1-1/4 connex bushing, and hex lock nut in the second hole (**See Figure 3-8.**)
2. Connect subsoiler points to each shank using 3/8 x 2 spring slotted pins.



**Figure 3-9: Hydraulic Lift Installation**

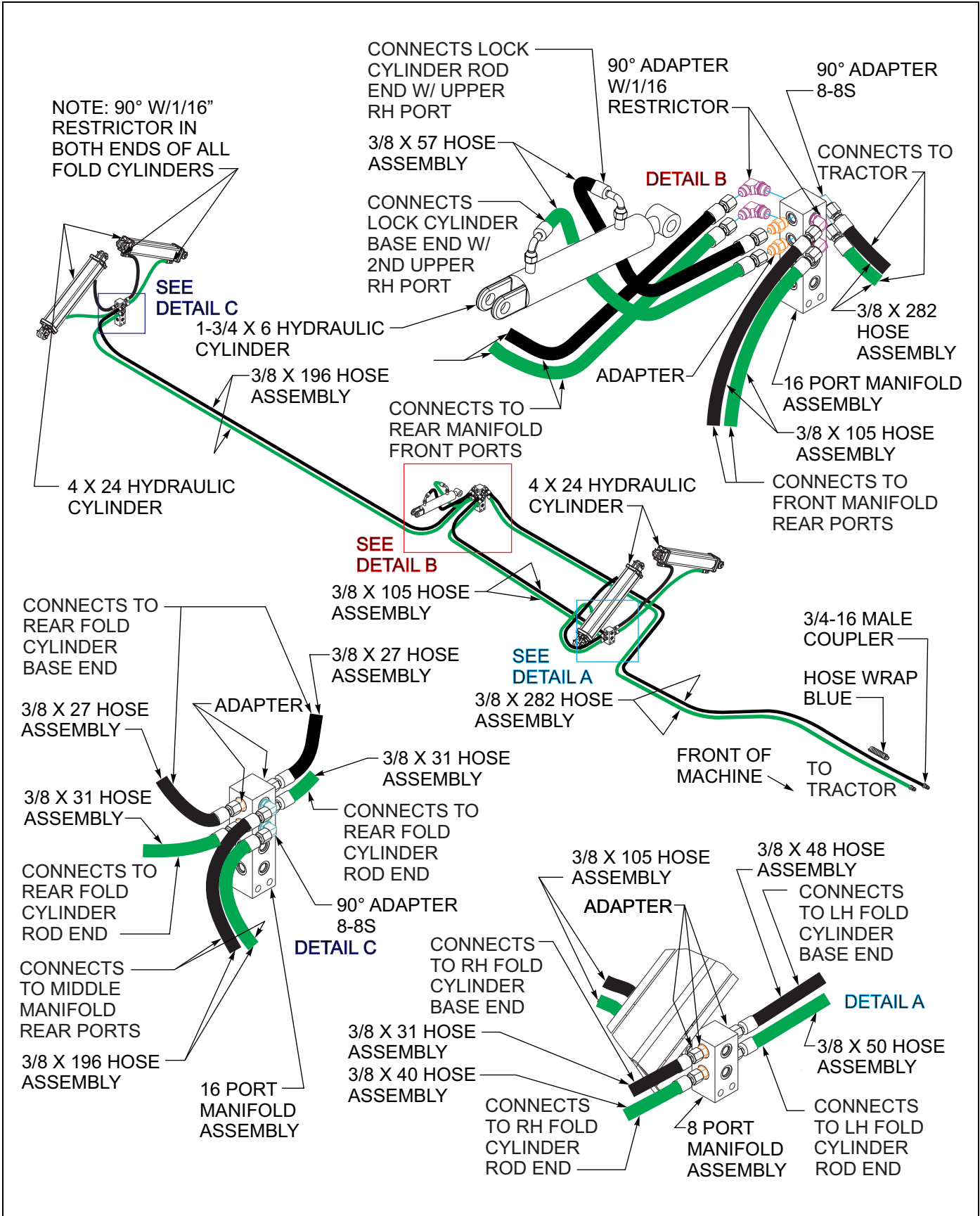
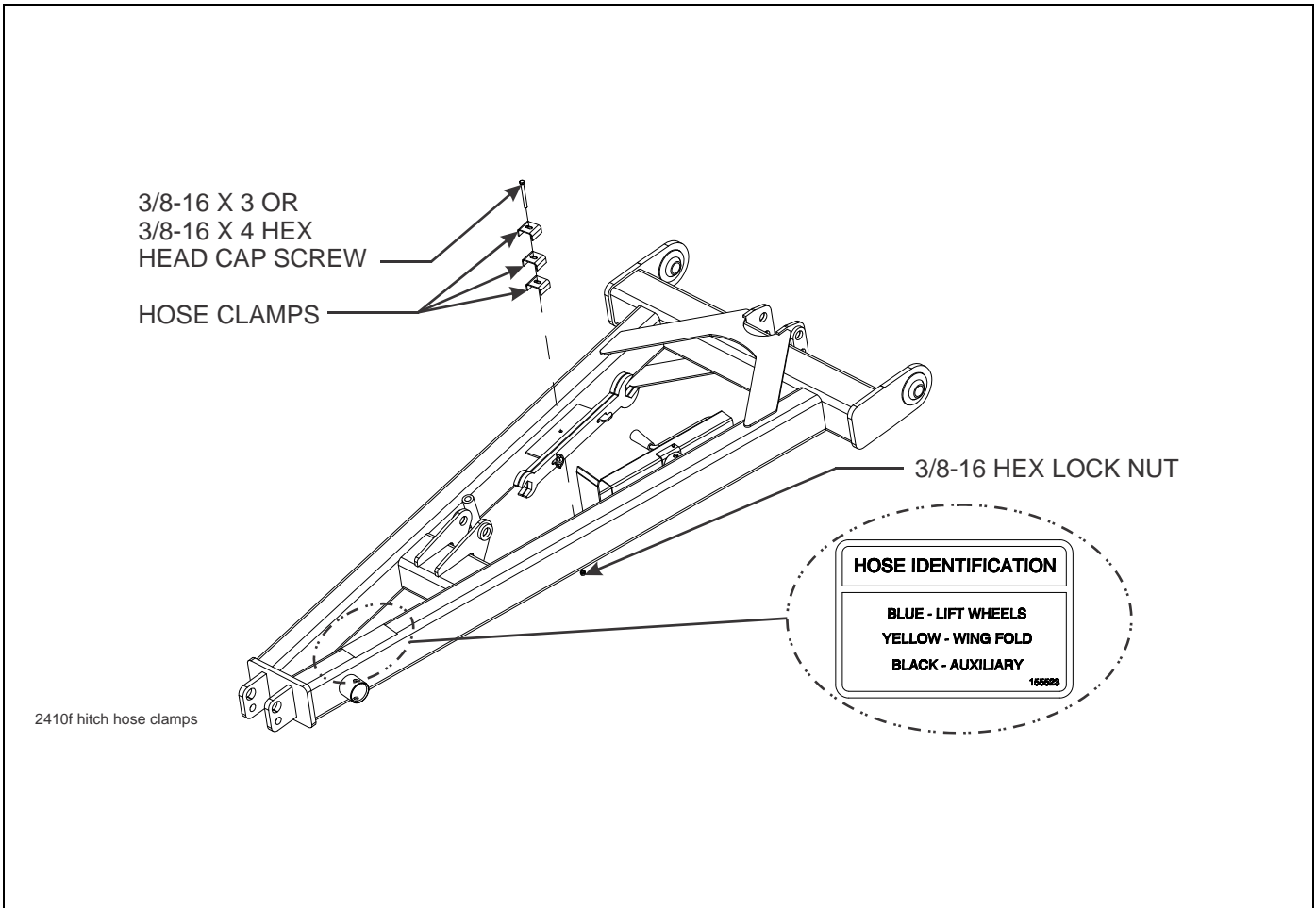

Figure 3-10: Hydraulic Fold Installation



**Figure 3-11: Hitch Hose Clamps and Color Designation**

## Hydraulic Installation

### NOTES

Refer to **Figure 3-9** for hydraulic lift diagram.

Refer to **Figures 3-10** for hydraulic fold diagrams.

1. Install a 16 port manifold to the front side of the manifold mount bracket at the center frame using 1/2-13 x 3-1/2 hex head cap screws and hex lock nuts.
2. Install a 16 port manifold on the front side of the rear inner tower plate using 1/2-13 x 3-1/2 hex head cap screws and hex lock nuts.
3. Install the 8 port manifold to the front side of the manifold mount bracket near the front of the unit using 1/2-13 x 3-1/2 hex head cap screws and hex lock nuts.
4. Install fittings into manifold according to **Figures 3-9 and 3-10**.

### NOTE

*Install 90 elbow w/ 1/16 restrictor to both front and rear top ports of the 16 port manifold near the center of the frame.*

5. Install wheel lift hoses per **Figure 3-9**.
6. Install hydraulic fold hoses per **Figure 3-10**.
7. Hold each system of hoses in place using 3/8-16 x 4 hex head cap screw, hose clamps, and hex lock nut (**See Figure 3-11.**)
8. Install steel plugs in any remaining open manifold or valve ports.

### NOTE

*Steel plugs will be used in the lower eight ports of each 16 port manifold for all units with either no finishing attachment or harrow only option included.*

9. Install hose wraps around system hoses per hose identification decal near hose couplers, putting both hoses inside wrap (**See Figure 3-11.**)

# ASSEMBLY INSTRUCTIONS

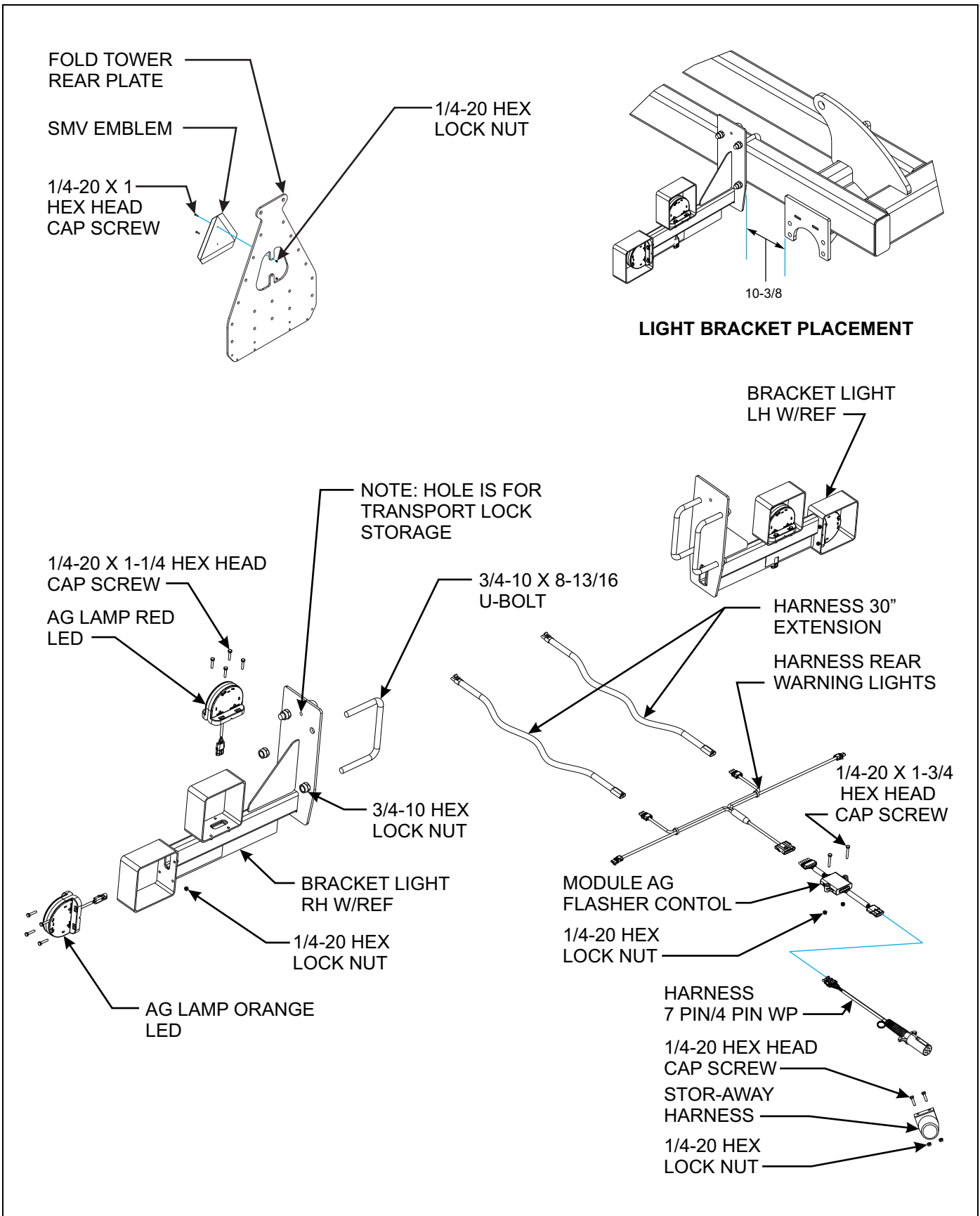

**Figure 3-12: Light Bracket Installation**

NOTE: IF REPAIRING OR REPLACING THE 7 PIN CONNECTOR, MATCH THE LETTERS AT THE BACK OF THE HARNESS TO THE 7 PIN CONNECTOR AS SHOWN. THE COLOR OF THE WIRE JACKET DOES NOT NECESSARILY MATCH THE COLOR MARKING OF THE 7 PIN CONNECTOR.

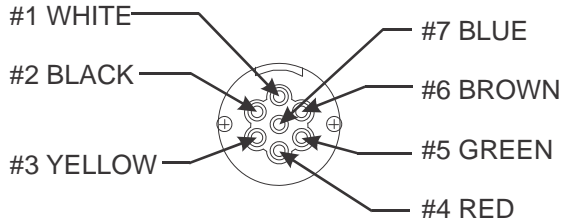

FACING 7-PIN CONNECTOR

electrical connector op

WIRING CHART	
7-PIN CONNECTION	4-PIN CONNECTION
GRND. 1	D
YEL. 3	B
GRN. 5	A
BRN. 6	C

Figure 3-13: 7 Pin Connector Detail and Wiring Chart

## Light Installation

### NOTE

See Figure 3-12 for Light and Bracket Installation.

1. Attach the LH and RH light bar assemblies to the main frame by locating on the front side of the rear tower plate just below the main frame. Place the light bar plate on the front side of the light bar tubes. Secure the light bar assemblies and the light bar plate using 1/2-13 x 3-3/4 hex head cap screws and hex lock nuts (See Figure 3-12.)
2. Attach amber lamps and outer to the LH and RH light brackets using 1/4-20 X 1-1/4 hex head cap screws and hex lock nuts.
3. Attach red brake lamps to inner tail light mounting bracket supports using 1/4-20 x 1-1/4 hex head cap screws and hex lock nuts.
4. Connect warning light harnesses to lights.
5. Attach SMV emblem on the back side of the rear fold tower rear plate using 1/4-20 x 1 hex head cap screws and hex lock nuts.

# ASSEMBLY INSTRUCTIONS

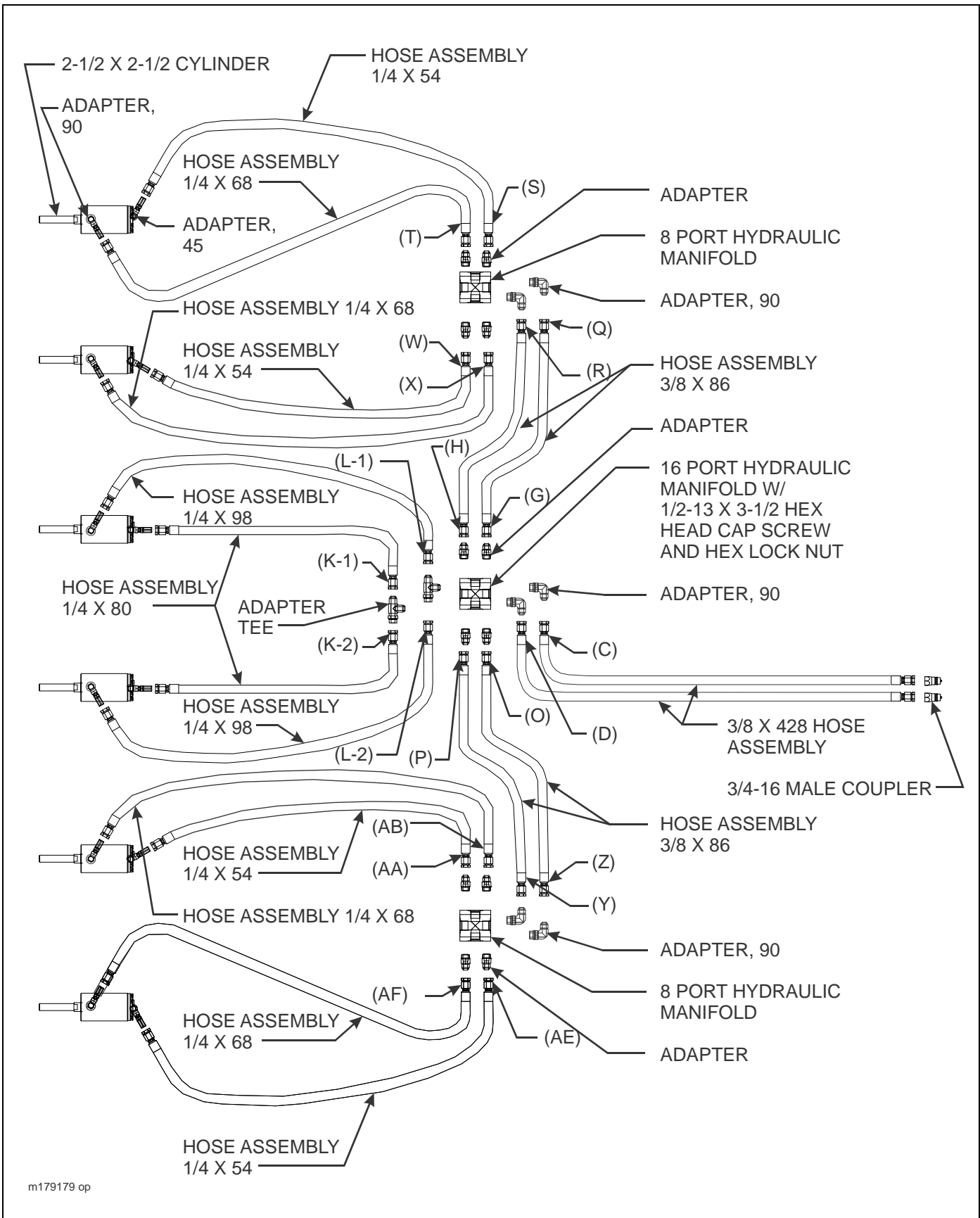
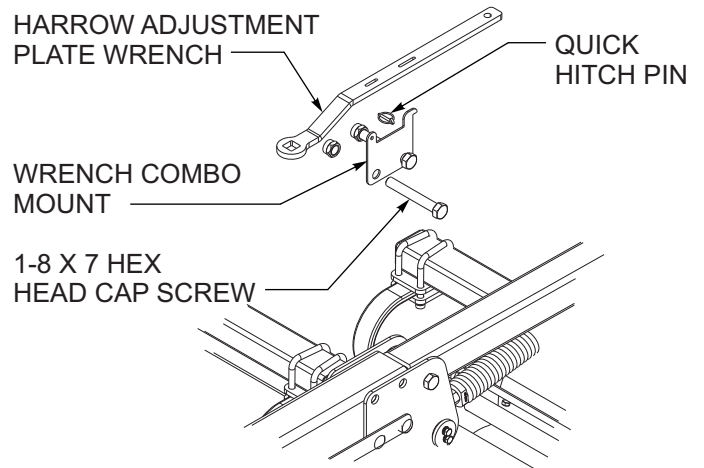
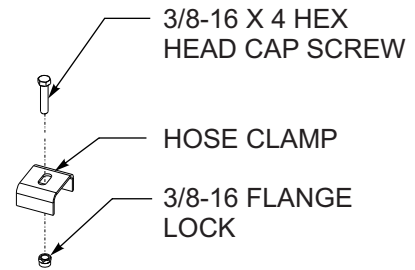
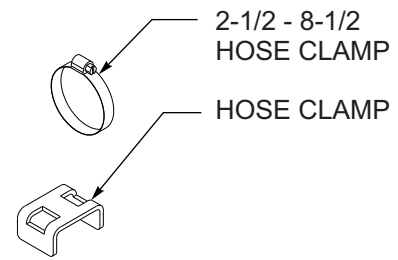
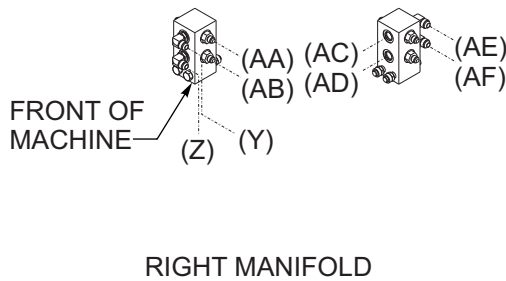
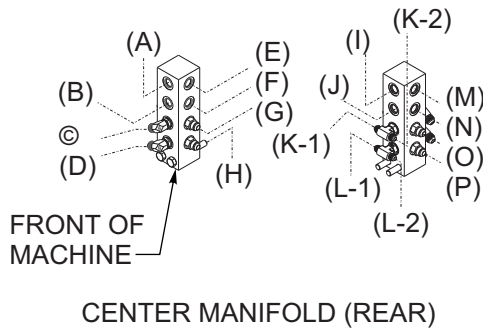
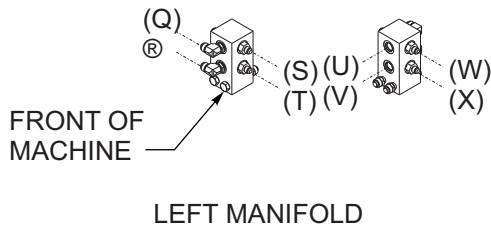

Figure 3-14: Finishing Combo w/ Reel Hydraulic Installation





1/2-13 X 4 RD  
HEAD SQ NECK  
SCREW

TINE RETAINER  
BUSHING

1/2-13 HEX  
LOCK NUT

HARROW ROTATE  
STOP PLATE

Coil Tine

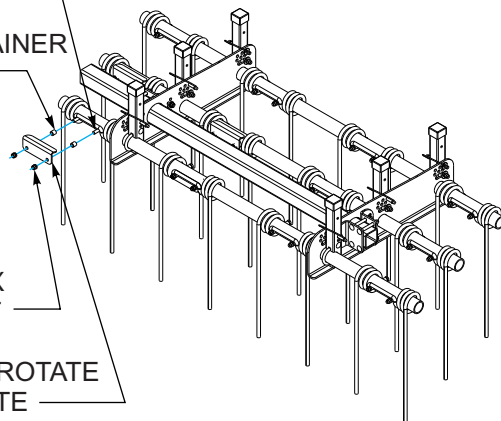

1. After installation of the Combo harrow, the front row of coil tines on the wing frames need to be modified to prevent them from rolling over during folding and transport.
2. On each tine remove hex nuts from the round head and hex bolts. Remove the hex bolt and replace with the same round head bolt as the opposite side, this is found in the crate of parts. Install tine retaining bushings and harrow rotate stop plate as shown. Reinstall nuts and tighten.
3. This change will only happen to the front row of each wing section.

Figure 3-15: Finishing Combo w/ Reel Hydraulic Manifold and Miscellaneous Details

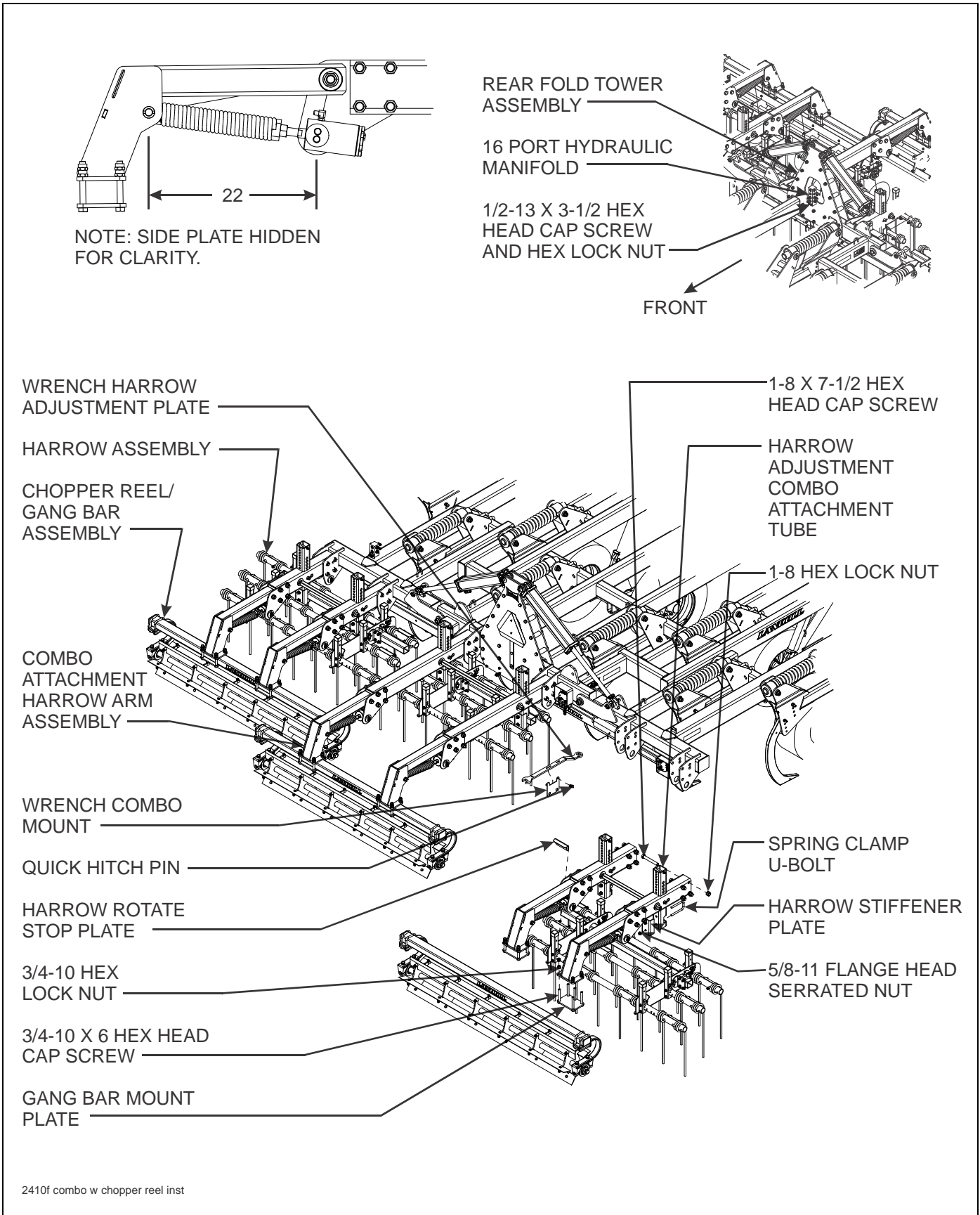

**Figure 3-16: Finishing Combo w/ Chopper Reel Installation**

## Finishing Combo w/ Chopper Reel Installation (Option)

### NOTES

Refer to **Figure 3-14** for hydraulic diagram.

See **Figure 2-3** for finishing combo w/ chopper reel placement dimensions.

1. Attach two combo attachment harrow arms to rear of frame using 1-8 x 7-1/2 hex head cap screws and hex lock nuts (**See Figure 3-16.**)
2. Install the manifold to the manifold bracket on the frame using 1/2-13 x 3-1/2 hex head cap screws and hex lock nuts.
3. Install fittings into manifold according to **Figures 3-14 thru 3-15.**
4. Install hoses per **Figures 3-14 thru 3-15.**
5. Install steel plugs in any remaining open manifold or valve ports.
6. Pull out 1-8 x 7 hex head cap screw and attach wrench combo plate to frame using the existing hardware.
7. Install wrench harrow adjustment plate to wrench combo plate using quick hitch pin.
8. Attach harrow adjustment combo attachment tubes to 3 row coil tine harrow assembly using spring clamp u-bolts, harrow stiffener plates, and 5/8-11 flange head serrated nuts.
9. Attach combo attachment arms to the chopper reel/gang bar assembly using gang bar mount plate, 3/4-16 X 6 hex head cap screws and double hex lock nuts.
10. Install 1/2-13 x 1-1/4 round head square neck screws through angle adjustment plate and gang bar plate as shown in **Figure 3-17.**

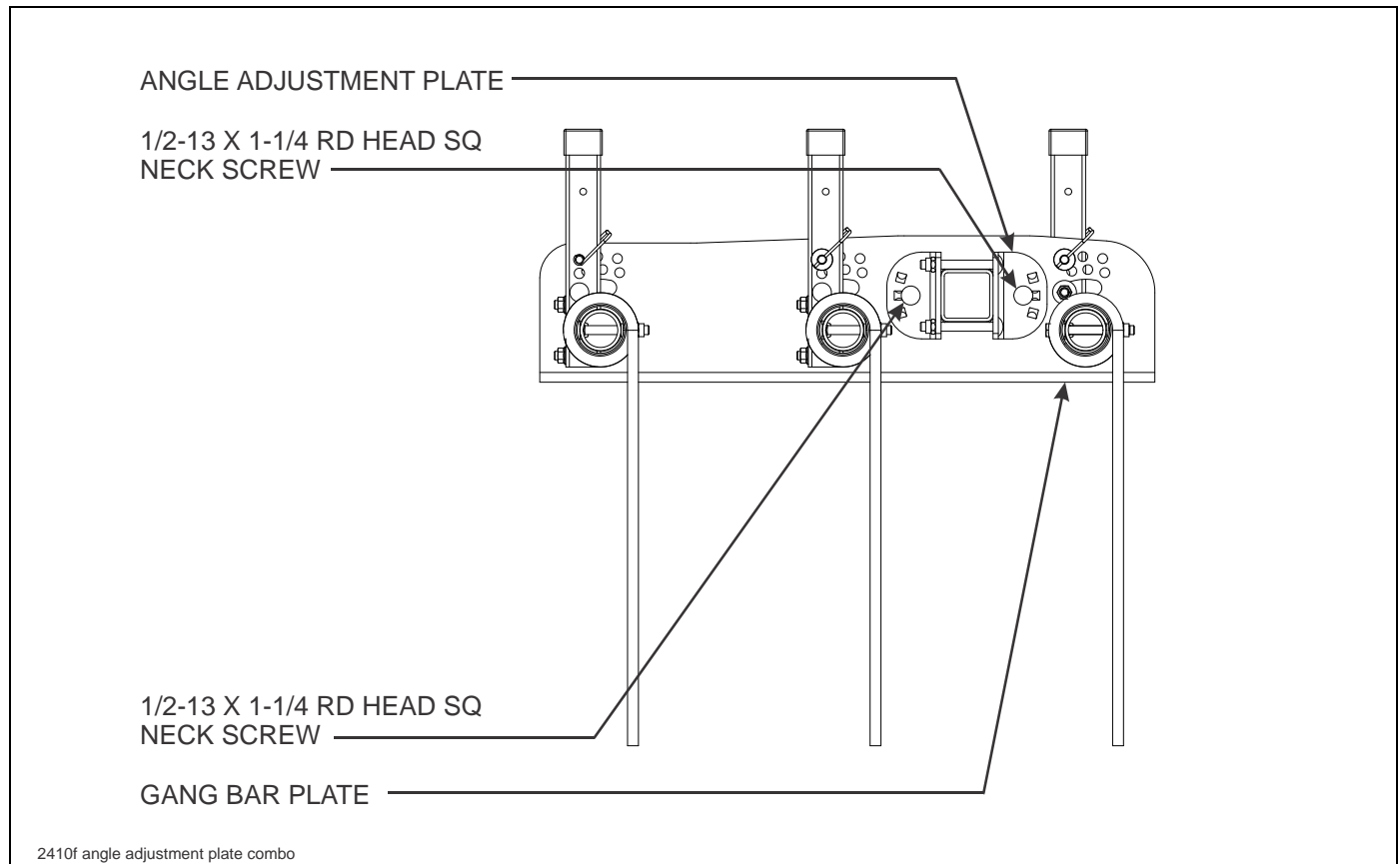

**Figure 3-17: Angle Adjustment Plate Installation**

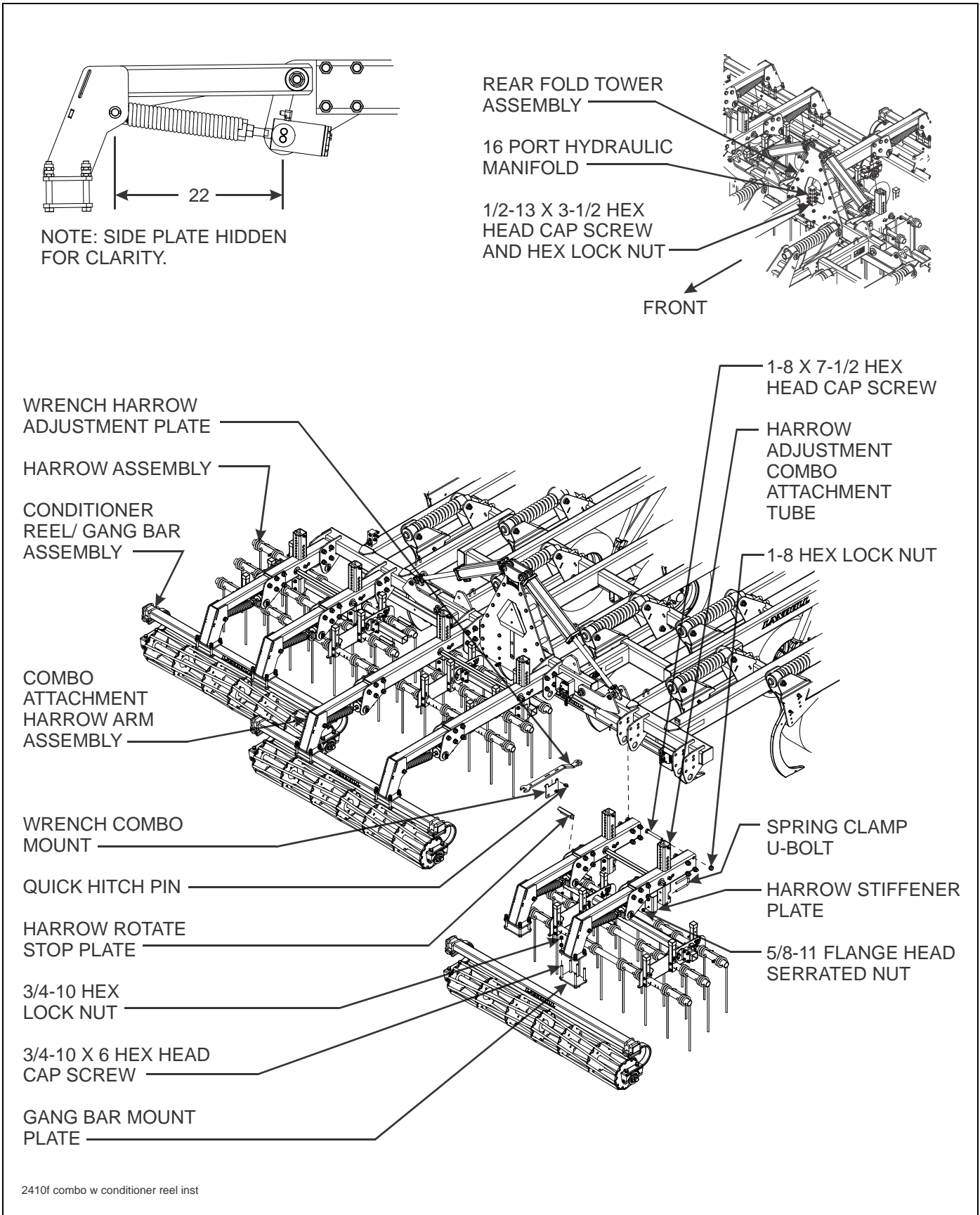

**Figure 3-18: Finishing Combo w/ Conditioner Reel Installation**

## Finishing Combo w/ Conditioner Reel Installation (Option)

### NOTES

Refer to **Figure 3-14** for hydraulic diagram.

See **Figure 2-4** for finishing combo w/ conditioner reel placement dimensions.

1. Attach two combo attachment harrow arms to rear of frame using 1-8 x 7-1/2 hex head cap screws and hex lock nuts (**See Figure 3-18.**)
2. Install the manifold to the manifold bracket on the rear of frame using 1/2-13 x 3-1/2 hex head cap screws and hex lock nuts.
3. Install fittings into manifold according to **Figures 3-14 thru 3-15.**
4. Install hoses per **Figures 3-14 thru 3-15.**
5. Install steel plugs in any remaining open manifold or valve ports.
6. Pull out 1-8 x 7 hex head cap screw and attach wrench combo plate to frame using the existing hardware.
7. Install wrench harrow adjustment plate to wrench combo plate using quick hitch pin.
8. Attach combo attachment harrow arms to 3 row coil tine harrow assembly using spring clamp u-bolts, harrow stiffener plates, and 5/8-11 flange head serrated nuts.
9. Attach combo attachment harrow arms to the conditioner reel/gang bar assembly using gang bar mount plate, 3/4-16 X 6 hex head cap screws and double hex lock nuts.
10. Install 1/2-13 x 1-1/4 round head square neck screws through angle adjustment plate and gang bar plate as shown in **Figure 3-19.**

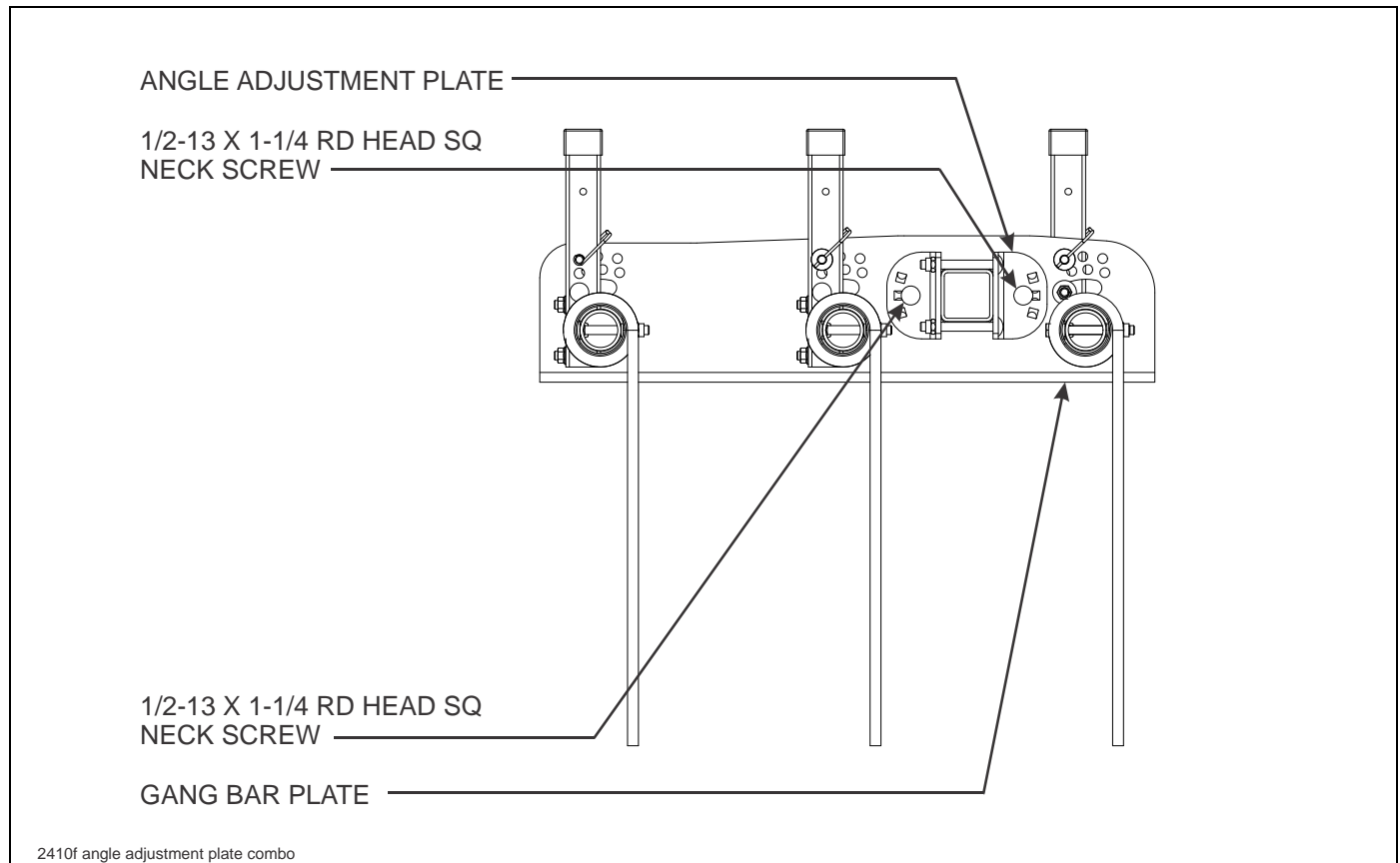

**Figure 3-19: Angle Adjustment Plate Installation**

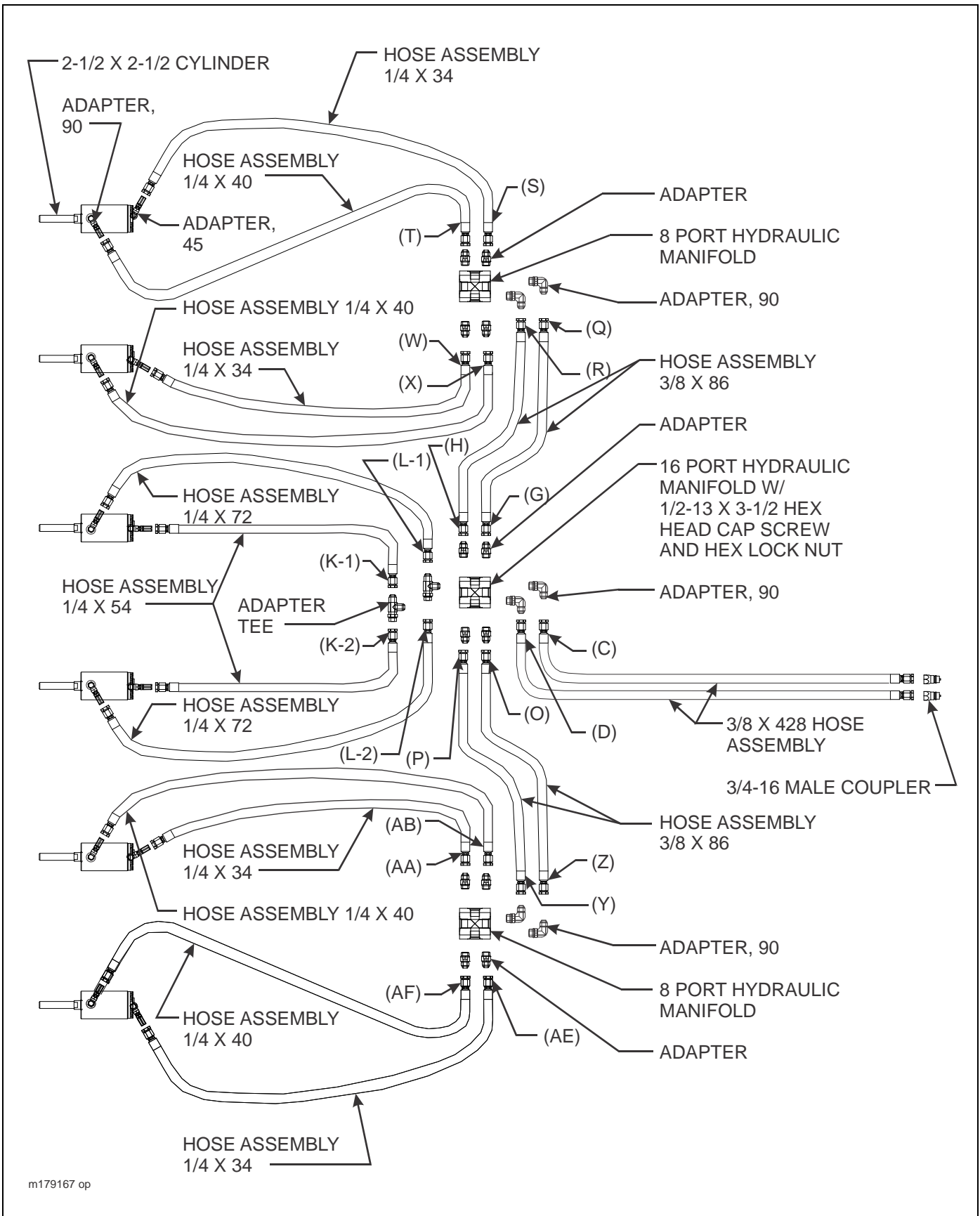

**Figure 3-20: Finishing Reel Hydraulic Installation**

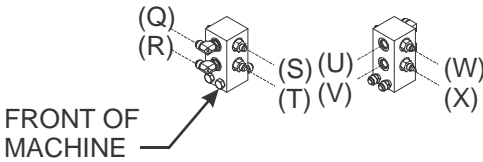

LEFT MANIFOLD

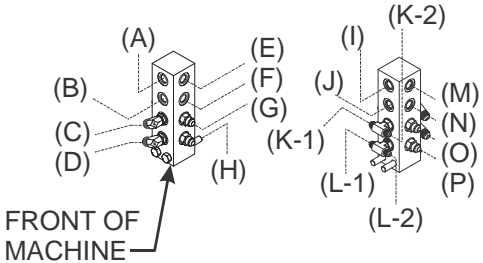

CENTER MANIFOLD (REAR)

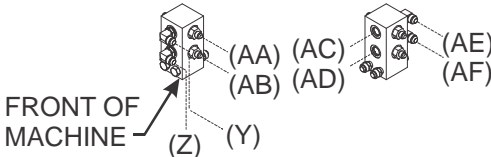

RIGHT MANIFOLD

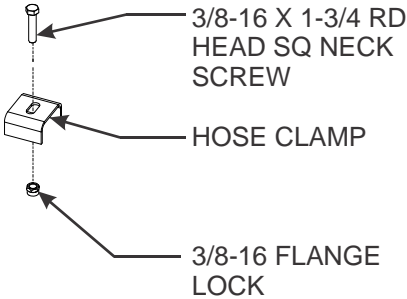

m179167 op p2

Figure 3-21: Finishing Reel Hydraulic Manifold and Miscellaneous Details

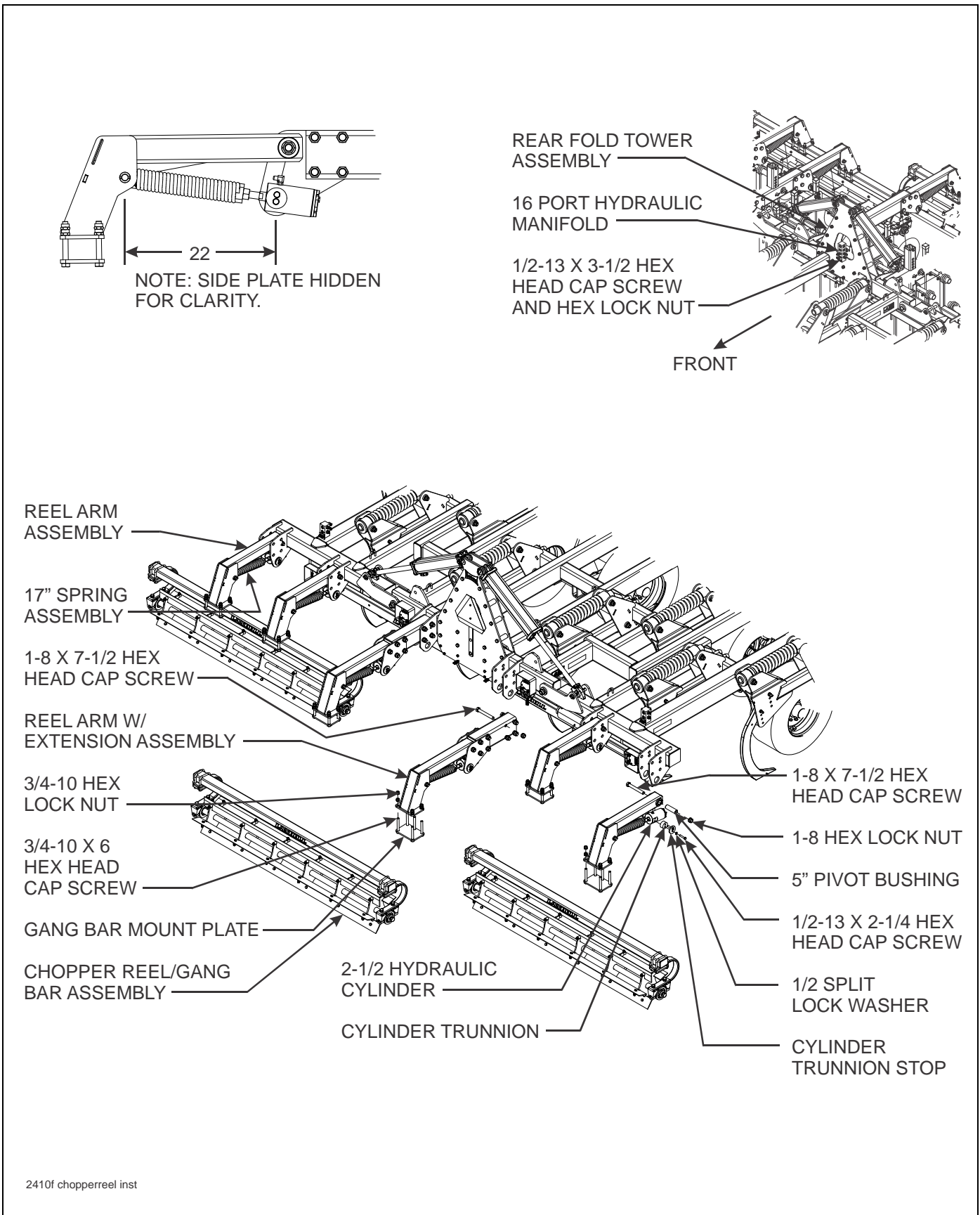

**Figure 3-22: Finishing Chopper Reel Installation (Option)**



## Finishing Chopper Reel Installation (Option)

### NOTES

Refer to **Figure 3-20** for hydraulic diagram.

See **Figure 2-5** for finishing chopper reel placement dimensions.

1. Attach reel arm assemblies to rear frame in second hole from top using 1-8 x 7-1/2 hex head cap screw, 5" pivot bushing, and hex lock nut (**See Figure 3-22.**)
2. Attach reel arms w/ extension assemblies to rear frame using 1-8 x 7-1/2 hex head cap screws and hex lock nuts.
3. Attach 17" spring assembly and 2-1/2 hydraulic cylinder to lower hole on rear frame using cylinder trunnion, cylinder trunnion stop, 1/2-13 x 2-1/4 hex head cap screw, and split lock washer.
4. Install the manifold to the manifold bracket on the frame using 1/2-13 x 3-1/2 hex head cap screws and hex lock nuts.
5. Install fittings into manifold according to **Figures 3-20 thru 3-21.**
6. Install hoses per **Figures 3-20 thru 3-21.**
7. Install steel plugs in any remaining open manifold or valve ports.
8. Attach chopper reel/gang bar assembly to reel arm assemblies using gang bar mount plates, 3/4-10 x 6 hex head cap screws, and double hex lock nuts.

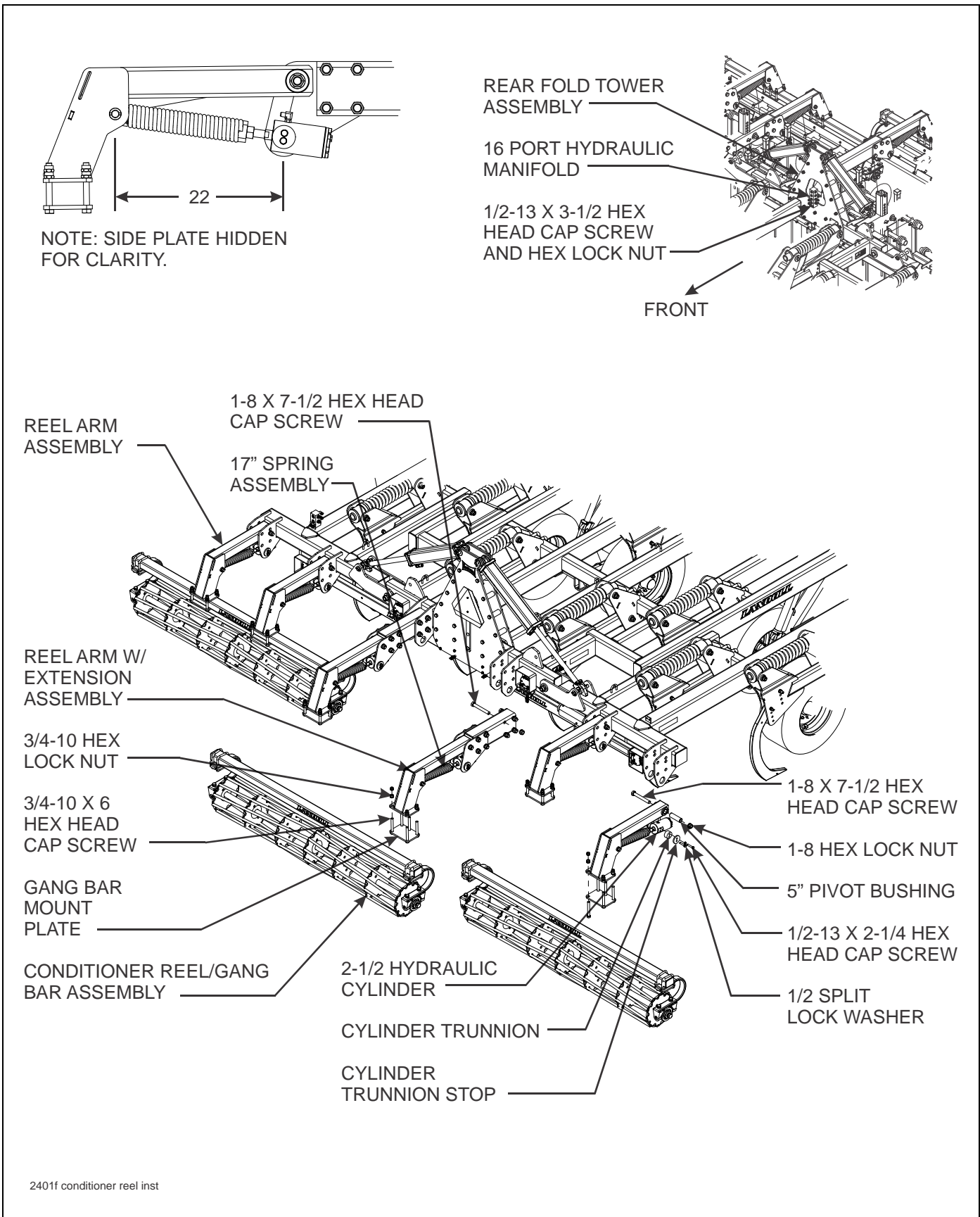

**Figure 3-23: Finishing Conditioner Reel Installation (Option)**

## Finishing Conditioner Reel Installation (Option)

### NOTES

Refer to **Figure 3-20** for hydraulic diagram.

See **Figure 2-6** for finishing conditioner reel placement dimensions.

1. Attach reel arm assemblies to rear frame in second hole from top using 1-8 x 7-1/2 hex head cap screw, 5" pivot bushing, and hex lock nut (**See Figure 3-23.**)
2. Attach reel arms w/ extension assemblies to rear frame using 1-8 x 7-1/2 hex head cap screws and hex lock nuts.
3. Attach 17" spring assembly and 2-1/2 hydraulic cylinder to lower hole on rear frame using cylinder trunnion, cylinder trunnion stop, 1/2-13 x 2-1/4 hex head cap screw, and split lock washer.
4. Install the 16 port hydraulic manifold to the rear fold tower assembly at the rear of the center frame using 1/2-13 x 3-1/2 hex head cap screws and hex lock nuts.
5. Install fittings into manifold according to **Figures 3-20 thru 3-21.**
6. Install hoses per **Figures 3-20 thru 3-21.**
7. Install steel plugs in any remaining open manifold or valve ports.
8. Attach conditioner reel/gang bar assembly to reel arm assemblies using gang bar mount plates, 3/4-10 x 6 hex head cap screws, and double hex lock nuts.

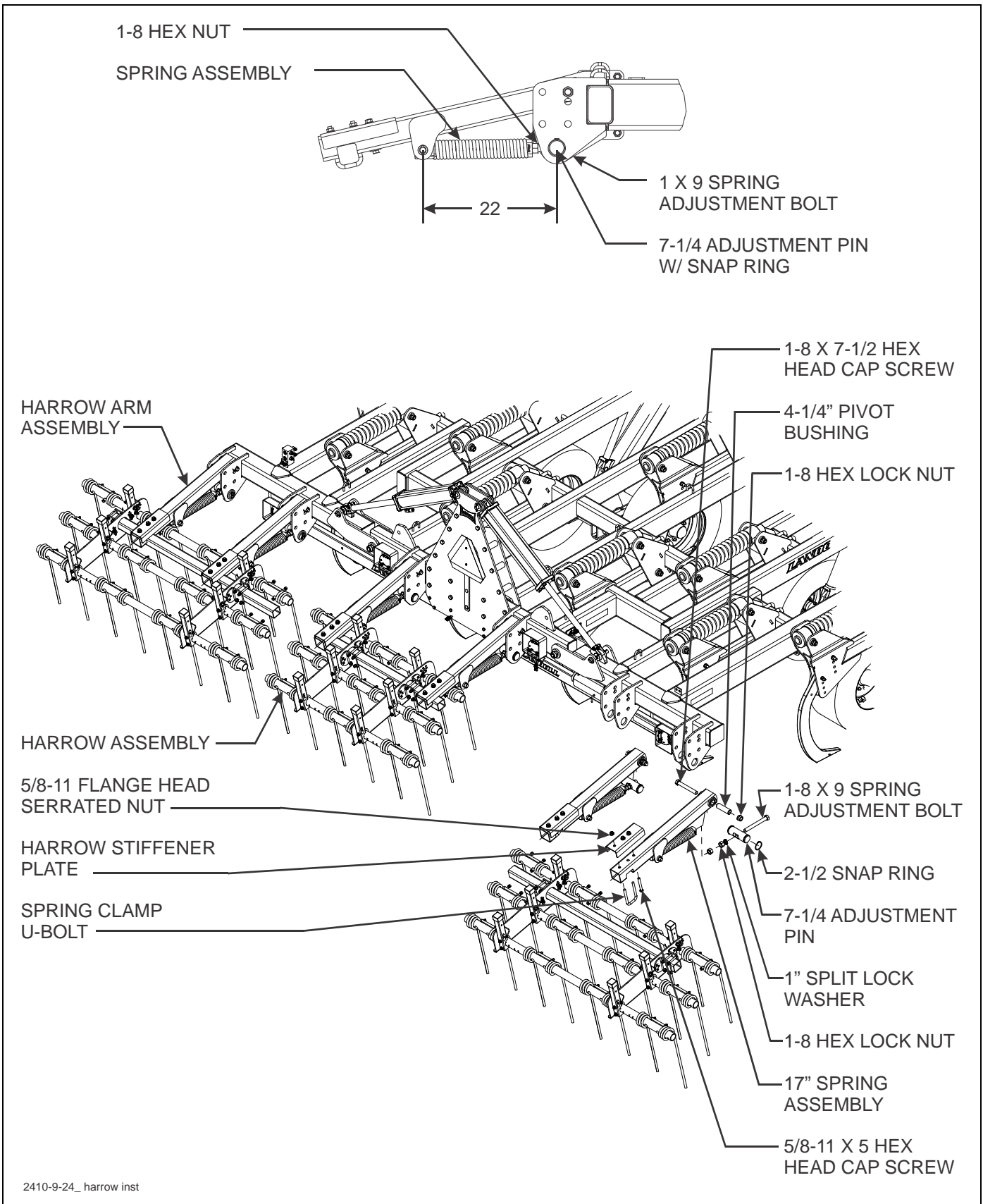

**Figure 3-24: Finishing Harrow Installation**

## Finishing Harrow Installation (Option)

See Figure 2-7 for 3 Row Coil Tine Harrow placement dimensions.

1. Attach harrow arms to rear of frame in top hole using 1-8 x 7-1/2 hex head cap screws and hex lock nuts (See Figure 3-24.)
2. Place 7-1/4" adjustment pin in lower hole on rear frame. Put 2-1/2" snap rings on adjustment pins to hold pin in place.
3. Attach 17" spring assembly to adjustment pin using 1-8 x 9 hex head cap screw, split lock washer, and hex lock nuts.
4. Attach harrow stiffener plate to top of harrow arm using 5/8-11 x 5 hex head cap screw and flange head serrated nut.
5. Attach harrow arms to 3 row coil tine harrow assembly using u-bolts, and 5/8-11 flange head serrated nuts. The u-bolt will go through both the harrow arm and harrow stiffener plate.
6. Install 1/2-13 x 1-1/4 round head square neck screws through angle adjustment plate and gang bar plate as shown in Figure 3-25.

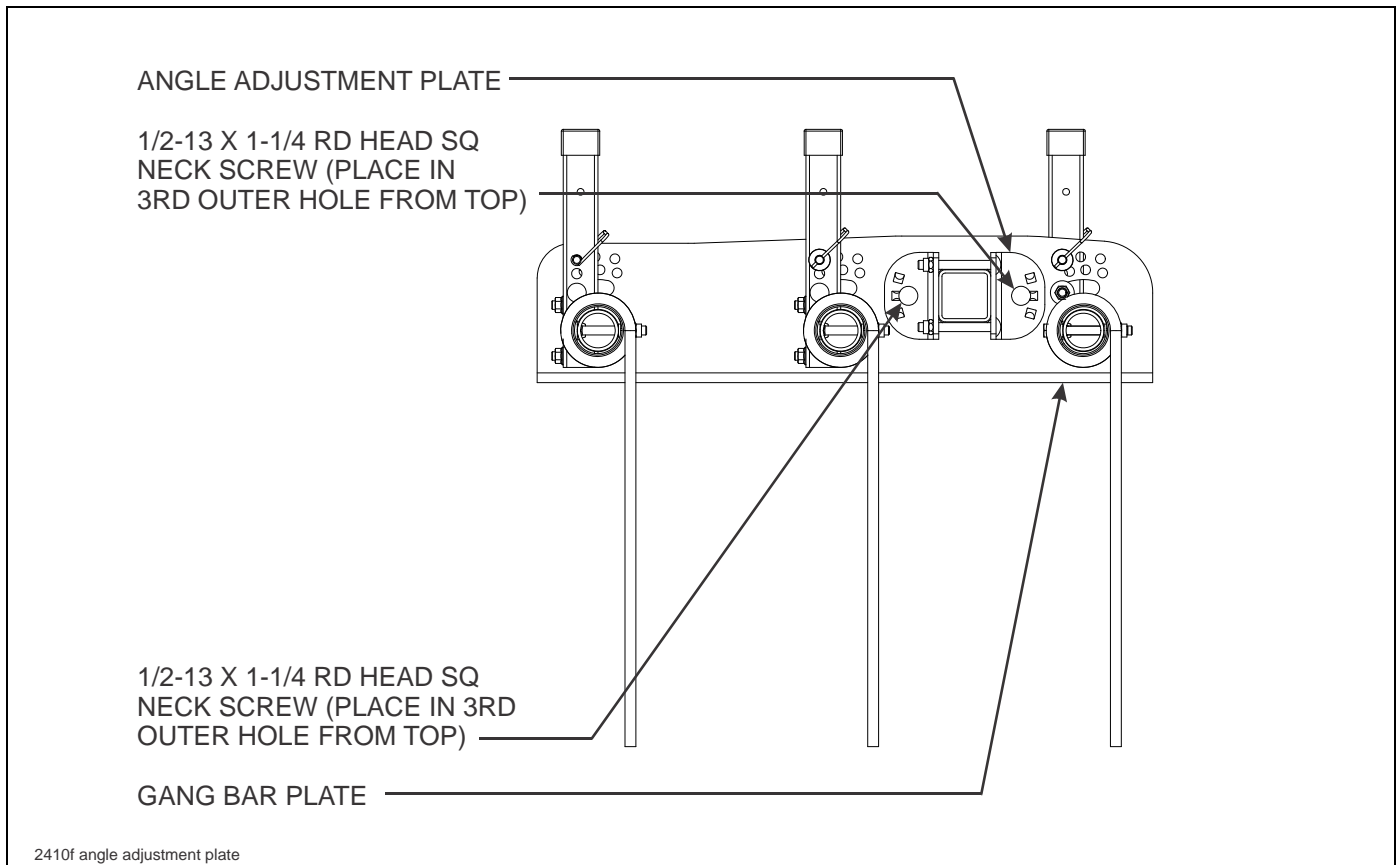

Figure 3-25: Angle Adjustment Plate Installation

### Final Assembly

1. Attach a tractor to the implement and charge the lift system hydraulics as described in **“Hydraulic Lift System” on page 4-3.**
2. Install the 1-1/2 x 16 lockouts on both 3-1/2 x 16 cylinders on the frame.
3. Connect lights to the tractor and verify operation.
4. Check tires for proper inflation.
5. Level the Weatherproofer I from front to rear as described in **“Leveling (Front-to-Rear)” on page 4-4.**
6. Inspect the final implement assembly, and verify that all bolts have been tightened, cotter pins spread, and that there are no leaking hydraulic connections.



#### CAUTION

**Tighten all 1-3/4” nuts to 1,200 foot-pounds of torque (See Figure 3-26.)**

7. Rotate each disc gang to verify that each gang rotates freely. Adjust any scrapers that may have shifted during shipment or assembly.
8. Lubricate the Weatherproofer I at all locations (**See “Lubrication Maintenance” on page 4-10.**)
9. Touch up with paint any areas that may have been scratched during moving, handling, or assembly.
10. Thoroughly read and understand the operating section before using the Weatherproofer I.

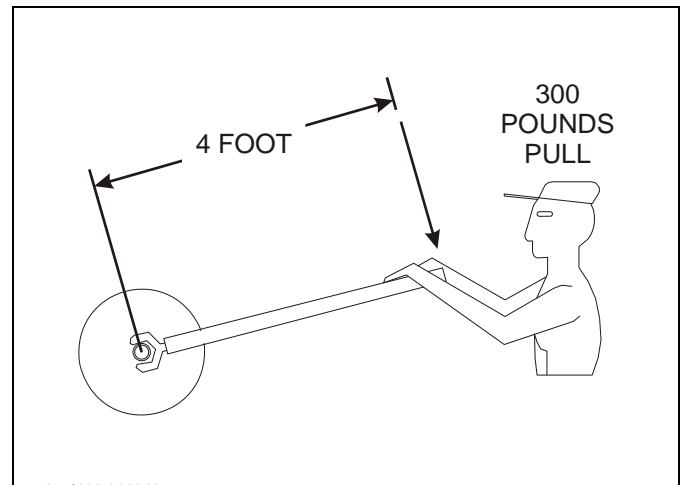

**Figure 3-26: 1,200 Foot-Pounds of Torque**







## Operation and Maintenance

---



### DANGER

Never allow anyone to ride on the 2410F Weatherproofer I at any time. Allowing a person to ride on the machine can inflict serious personal injury or death to that person.



### DANGER

Disc blades are extremely sharp. Exercise extreme care when working on or near disc blades. Do not allow discs to roll over or fall onto any bodily part. Do not allow wrenches to slip when working near disc blades. Never push wrenches toward disc blades. Do not climb over machine above disc blades. Failure to stay clear of disc blade edges can cause serious personal injury or death.



### WARNING

All hydraulically elevated equipment must have cylinder lockouts installed or be lowered to the ground, when servicing or when equipment is idle. Failure to take preventive measures against accidental lowering can result in serious personal injury.



### DANGER

When transporting the unit, place cylinder lockouts in the transport lock position after fully extending the cylinders. Insert the lockout pins to secure the cylinder lockouts. Failure to lockout the cylinders can cause the unit to settle during transport, which can result in serious injury or death and cause damage to the equipment.



### CAUTION

When transporting farm implements on public roads, it is the responsibility of the operator to abide by state and local laws concerning wide loads, speed, safety emblems and safety lighting equipment. Drive at safe speeds. Particularly when rounding corners, crossing rough ground or driving on hillsides, to prevent tipping the tractor.



### DANGER

Always lock the tractor drawbar in the center position when transporting the unit. Failure to do so can result in serious injury or death and cause damage to the equipment.

### Tractor Preparation

The Landoll 2410F Weatherproofer I is designed to be pulled by tractor equipped with a double lip or clevis type hitch. If your tractor is not equipped as such, you need to purchase the hitch from your local tractor dealer. If your Weatherproofer is equipped with the clevis option, this should be removed. The clevis option is only for transport use. Before attaching the Weatherproofer, prepare the tractor as follows:

1. Inflate the rear tractor tires equally and add ballast according to the tractor operator's manual.
2. Lock the tractor drawbar in the center position.

### Weatherproofer Preparation

1. Prior to operating the 2410F Weatherproofer I, inspect it thoroughly for good operating condition.
2. Replace worn or missing parts.
3. When the machine is new, check the bolt tightness after a few hours of operation. Tighten any loose nuts or bolts. Check the gauge wheel lug bolts daily.
4. Check the lift wheel tire inflation. Inflate all tires equally to avoid side draft. Follow the tire manufacturer's recommended pressures listed on the sidewall of the tires.
5. Check disc scrapers for proper adjustment to the disc blade (**See Figure 4-1.**)
  - a. Loosen U-bolts. Slide scraper assembly to adjust clearance to 1/8" to 1/4".

#### **IMPORTANT**

**Under certain conditions, it may be beneficial to set scrapers as much as 1" away from the discs.**

6. Lubricate the machine as shown in "**Lubrication Maintenance**" on page 4-10 (**See Figure 4-11.**)

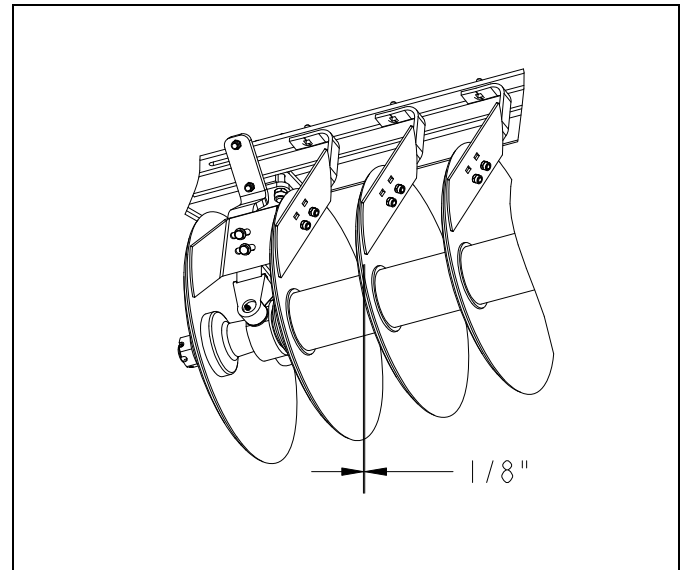

**Figure 4-1: Disc Scraper Clearance to Disc Blade**

### Attaching to the Tractor

1. Align the tractor drawbar with the machine. Attach the unit with proper size hitch pin. Attach safety chain and plug in light plug.
2. Clean all hydraulic couplings and attach to the tractor. When properly attached, the hydraulic control lever should cause the Weatherproofer to:
  - a. Lower to the ground when the control arm is moved forward or downward, and
  - b. Raise when the control arm is moved backward or upward.
3. Fully extend the hydraulic gauge wheel cylinders, and place the cylinder lockouts in the transport lock position over the cylinder rods. Secure the lockouts with the lockout pins.
4. Always place the swivel jack on the interior mount before setting the machine in motion. Remove rear jack stand if an attachment is used.

## Hydraulic Lift System

The Weatherproofer I is equipped with a hydraulic lift system to raise and lower the unit in the field.



### WARNING

Escaping hydraulic fluid can cause serious personnel injury. Relieve system pressure before repairing, adjusting, or disconnecting. Wear proper hand and eye protection when searching for leaks. Use cardboard instead of hands (See Figure 4-2.) Keep all components (cylinders, hoses, fittings, etc.) in good repair.

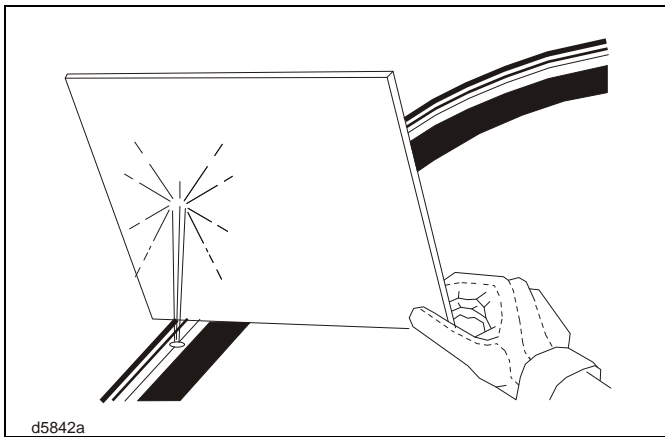

Figure 4-2: Hydraulic Leak Detection

1. The hydraulic lift system contains cylinders plumbed together. It is important that the cylinders be connected in the proper series for the lift system to operate correctly.
2. The hydraulic system is not filled with oil and should be purged of air before transporting and field operations. Carefully hitch the Weatherproofer I to the tractor and connect the hydraulic lift hoses. Check to make sure the tractor hydraulic reservoir is full of the manufacturer's recommended oil. Slowly raise the machine. With all cylinders fully extended remove the 1-1/2 X 16 transport lockouts (See Figure 4-3.) Store transport lockouts as shown in Figure 4-4. Lower and raise the unit to verify that cylinders are working simultaneously throughout the stroke. Do not loosen any hoses or fittings. Recheck tractor reservoir to make sure it is within operating limits.

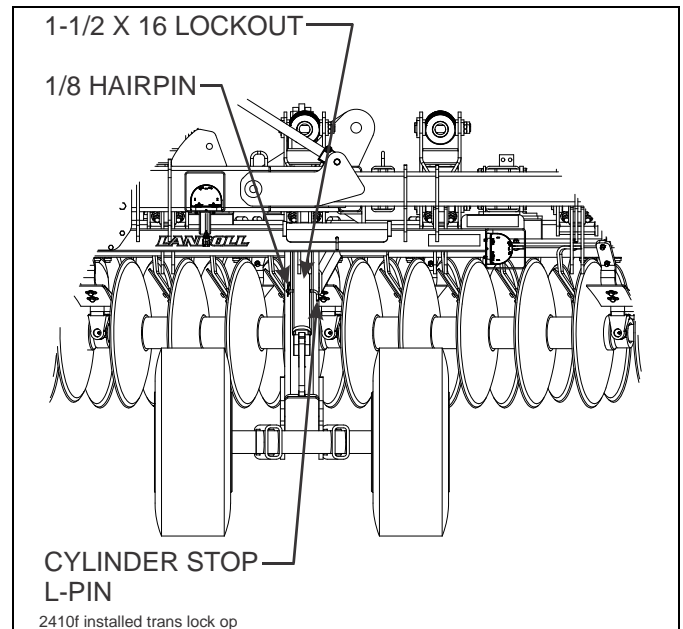

Figure 4-3: Installed Transport Locks

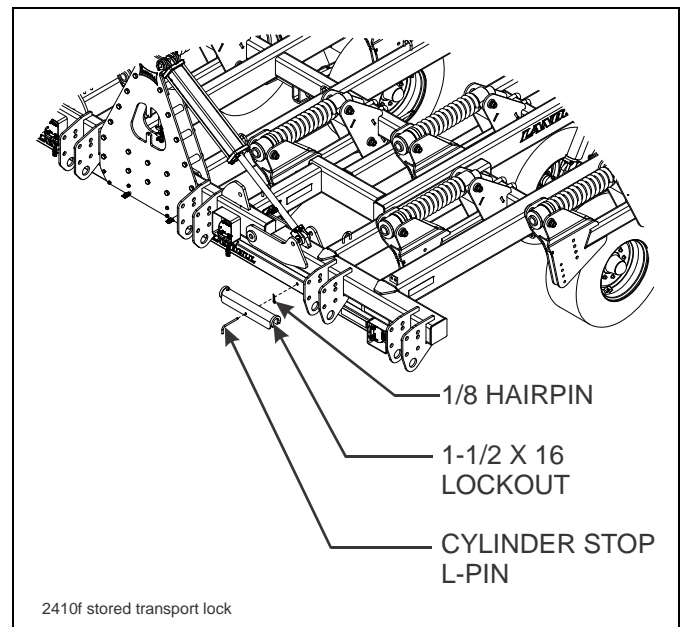

Figure 4-4: Stored Transport Locks

## General Operation

1. The horsepower requirements are typically 40-50 horsepower per shank. This will vary widely due to speed, depth, moisture, residue and types of soils. Local dealers can help in making recommendations for your areas.
2. Operating speed is typically 4.5-6 mph. Excessive speed can cause the unit to bounce, uneven depth, and create undesirable ridges.
3. Lift wheels must always be be in contact with the ground and carrying some implement weight. Lift wheels are used to gauge the depth and to control the leveling feature.
4. Do not turn with the Weatherproofer I in the ground. This can put excessive side load on the gangs and hitch. Raise the unit fully when making turns to prevent gouging and pushing a ridge.

## Field Operation

1. Raise the unit to take the weight off of the transport locks. Remove the transport locks from the lift cylinders. Store the transport locks on the retainers above the main lift (See Figure 4-5.)

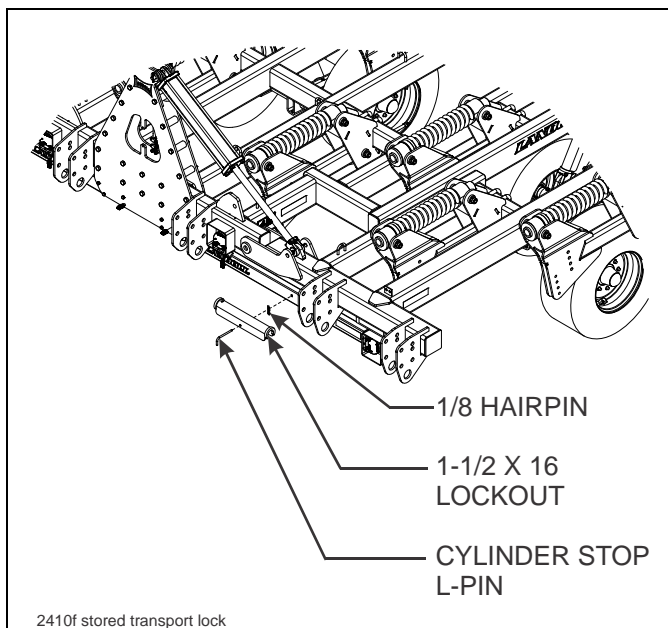

Figure 4-5: Stored Transport Locks

## Leveling (Front-to-Rear)

### NOTE

*The Weatherproofer I will have to be field leveled for optimum performance. Once leveling is complete, it is normal operating procedure for machine to bias forward when fully raised allowing additional ground clearance for rear attachment.*

1. The leveling feature on the Weatherproofer I is used to keep the machine level when raising the unit from a working position to a transport position. The leveling feature is also used to level the unit from front-to-rear to perform a level operation in the field.
2. The unit should be level from front to rear. This will reduce horsepower requirements, allow a more uniform tillage operation, and reduce unnecessary point wear.
3. To adjust the leveling feature, loosen jam nuts at each end of the radius rod using the adjustment wrenches (See Figure 4-6.) To raise the front of the Weatherproofer I, lengthen the radius rod assembly. To lower the front of the Weatherproofer I, shorten the radius rod assembly. After adjusting, retighten jam nuts at each end. Adjustments should be made in small increments.

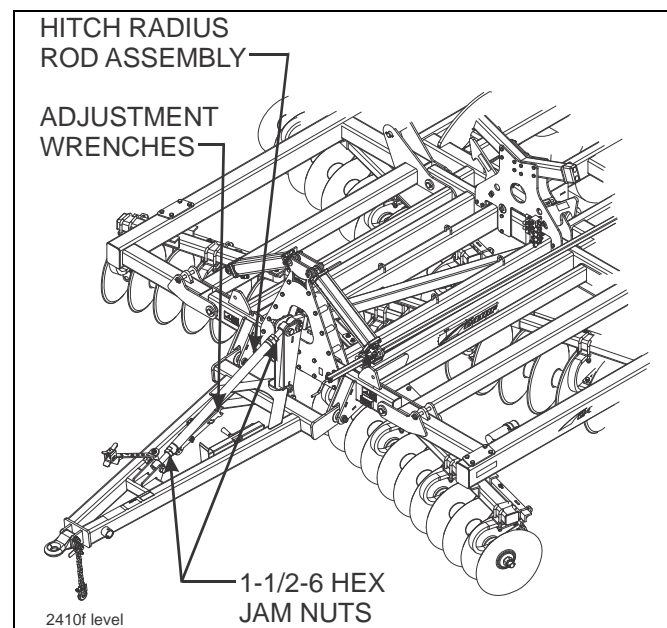

Figure 4-6: Radius Rod Leveling Adjustment

## Disc Blades

1. The 2410F Weatherproofer I is equipped with 24" or 26" disc blades.
2. The 24" diameter blades are concave with a thickness of 4 ga (.256") and are standard for the 2410F Weatherproofer I.
3. Sharpening – In some cases there is a desire to sharpen disc blades for improved cutting. There are several people who roll-sharpen disc blades. Most disc blades used today are made of chrome-boron steel. The chrome-boron steel has a higher hardness than traditional carbon-steel blades for increased wear. Higher hardness makes roll sharpening more difficult often with mixed results, and is not covered by warranty. Disc blade manufacturers will not cover any alterations to blades other than the place of manufacture. Results from roll-sharpening damage may not be immediate, and may take more than a season to be noticeable. If you choose to sharpen disc blades, check with local dealers for reputable experienced sharpeners that will stand behind their work.



### DANGER

Disc blades are extremely sharp. Exercise extreme care when working on or near disc blades. Do not allow discs to roll over or fall onto any body part. Do not allow wrenches to slip when working near disc blades. Never push wrenches toward disc blades. Do not climb over machine above disc blades. Failure to stay clear of disc blade edges can cause serious personal injury or death.

## Depth Stop Adjustment (Manual)

The operating depth of the Weatherproofer I is controlled by a single-point depth stop. The stop is located at the center front of the machine.

1. Adjust the depth stop by turning the handle in (clockwise) to increase operating depth (**See Figure 4-7.**) Turn the handle out (counter-clockwise) to decrease operating depth.
2. The gauge on the side of the depth stop tube gives a reference for depth setting. The "A" setting refers to maximum operating depth.

### IMPORTANT

**For maximum operating depth, the lift wheels must be in contact with the ground and carry some of the machine weight. Raising the lift wheels off the ground permits uncontrolled depth and does not allow the leveler to function properly.**

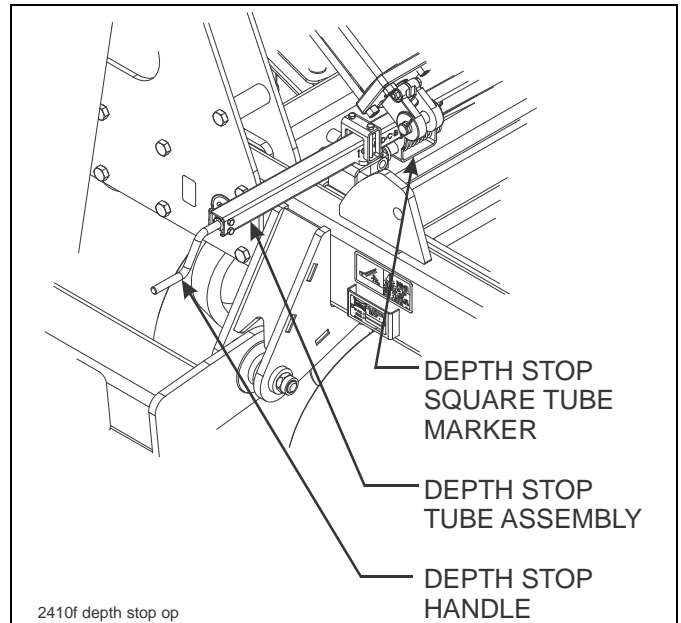

Figure 4-7: Depth Stop Adjustment (Manual)

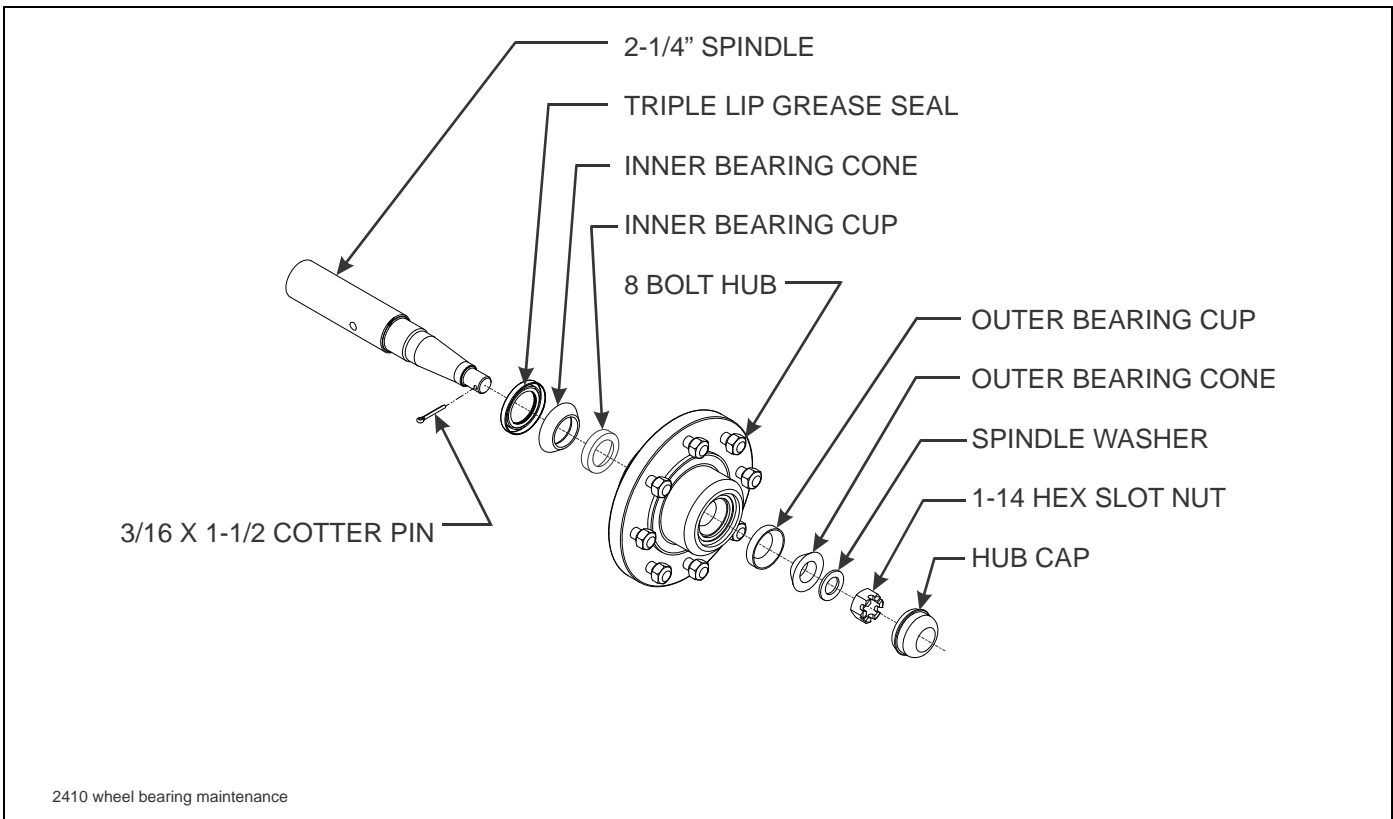

Figure 4-8: Wheel Bearing Maintenance

## Wheel Bearing Maintenance

Wheel bearing maintenance should be performed at the beginning of every season of use. Check the wheel bearings periodically for excessive end play. If needed, adjust or replace them using the following procedure:

1. Place the frame on blocks or stands sufficient to lift the tire clear of the ground.
2. Remove the tire.
3. Remove the hub cap, cotter pin, slotted nut and washer (**See Figure 4-8.**)
4. Remove the hub. Clean and inspect the bearings and hub cavity. Replace any worn or defective parts.
5. Repack the bearings using a high-quality wheel bearing grease.
6. Slide the triple lip seal onto the spindle. Do not install the seal into the hub.
7. Slide the inner bearing cone and hub onto the spindle.

8. Install the outer bearing cone, washer and slotted nut.
9. Tighten the slotted nut while rotating the hub until there is a slight resistance to wheel rotation. Then, back the slotted nut off one notch, until the wheel rotates freely without end play.
10. Slide the triple-lip seal to the hub and install the seal in the hub.

### NOTE

*The triple-lip seals should point away from the hub to keep contaminants out and allow grease to pass.*

11. Install a new cotter pin and replace the hub cap.

## Hydraulic Maintenance

1. Check the tractor hydraulic fluid level per tractor owners manual and after any leakage. Check fluid level with the cylinders in the retracted position.
2. If a cylinder or valve leaks, disassemble the parts to determine the cause of the leak. Any time a cylinder is opened up, or whenever any seal replacement is necessary, it is advisable to clean all parts and replace all seals. Seal kits are available from your Landoll dealer.
3. Check all hydraulic hoses weekly. Look for binding or cracking. Replace all worn or defective parts immediately.

### IMPORTANT

**Lower the unit to the ground, and relieve hydraulic pressure before attempting to service any hydraulic component.**

4. Transport locks are provided to hold the implement in a raised position. Do not attempt to perform any service work under the implement without first installing the transport locks. Before servicing any hydraulic component, lower the implement to the ground and relieve all system pressure. If a hydraulic component is disconnected, repaired, or replaced, it will be necessary to purge the system of air before operation. **See “Hydraulic Lift System” on page 4-3 on how to purge the hydraulic systems.**

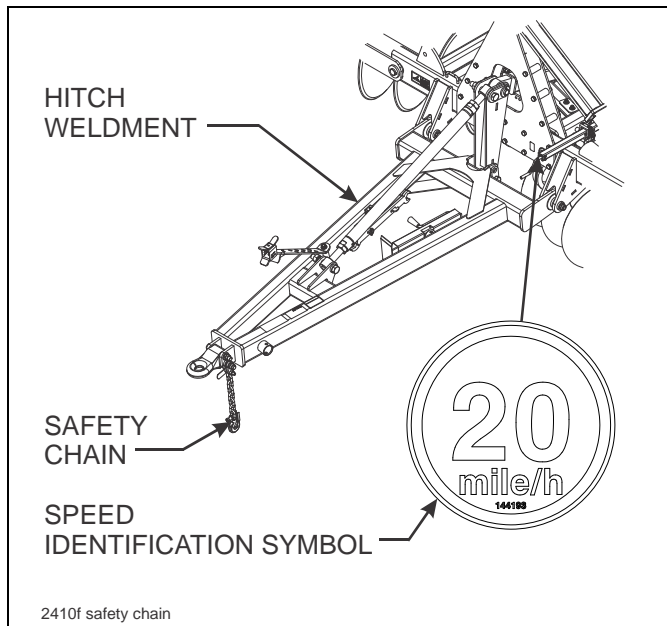

**Figure 4-9: Hitch and Safety Chain**

## Transport

1. Check and follow all federal, state, and local requirements before transporting the Weatherproofer I.
2. The Weatherproofer I should be transported only by a tractor required for field operation. The implement weight should not exceed more than 1.5 times the tractor weight. Unless noted on the implement, maximum transport speed is 20 mph for the implement. Slow down when driving on rough roads. Reduce speed when turning, or on curves and slopes to avoid tipping.
3. A safety chain is provided with the implement to insure safe transport.
  - a. The safety chain should have a tensile strength equal to or greater than the gross weight of the implement. The chain is attached to the lower hitch clevis hole with two flat washers between the clamp plates to assure a tight connection. Always use a 1" diameter Grade 8 bolt for this connection.
  - b. Attach the safety chain to the tractor drawbar **(See Figure 4-9.)** Provide only enough slack in the chain for turning. Do not use an intermediate chain support as the attaching point for the chain on the tractor. Do not pull the implement by the safety chain.
  - c. When unhitching from the tractor attach the hook end of the chain to a free link close to the hitch clevis for storage. This will keep the hook off the ground, reducing corrosion and keep the hook functioning properly.
  - d. Regularly inspect the safety chain for worn, stretched, or broken links and ends. Replace the safety chain if it is damaged or deformed in any way.

## OPERATION AND MAINTENANCE

4. Check that tires are of proper size, load rating, and inflated to manufacture specifications before transporting. Check wheel lug bolts to insure tightness.

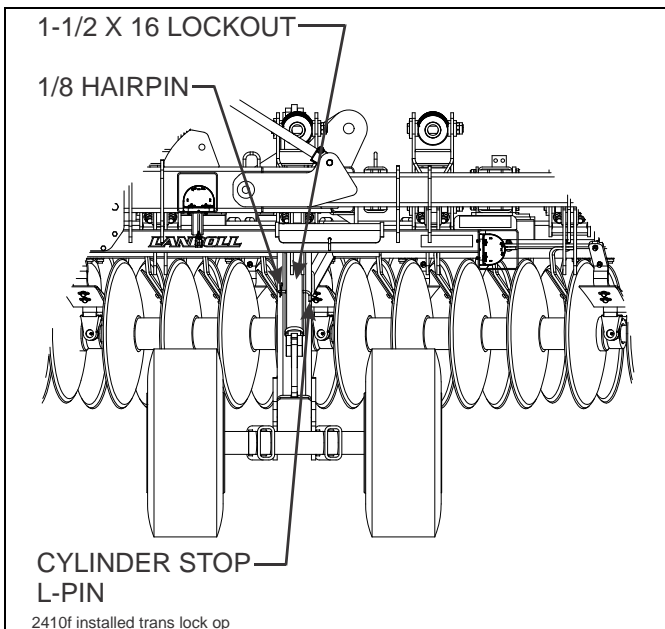

**Figure 4-10: Installed Transport Locks**

5. Know the transport heights and widths of the unit before transporting. Attachments can increase the transport dimensions of the implement. Use caution when transporting near bridges and power lines.



### WARNING

**Electrocution can occur without direct contact.**

6. Raise the unit to full transport height.
7. Install transport locks on both lift cylinders. Do not depend solely on implement hydraulics for transport. (See Figure 4-10.)



### WARNING

**Failure to use transport lock pins during transport may result in permanent equipment damage, serious injury, or death.**

8. Transport during daylight hours whenever possible. Always use flashing warning lights, except where such use is prohibited by law. Make sure lights, reflectors and SMV emblem are clearly visible and operating. Remove any obstructions such as dirt, mud, stalks or residue that restricts view before transporting.



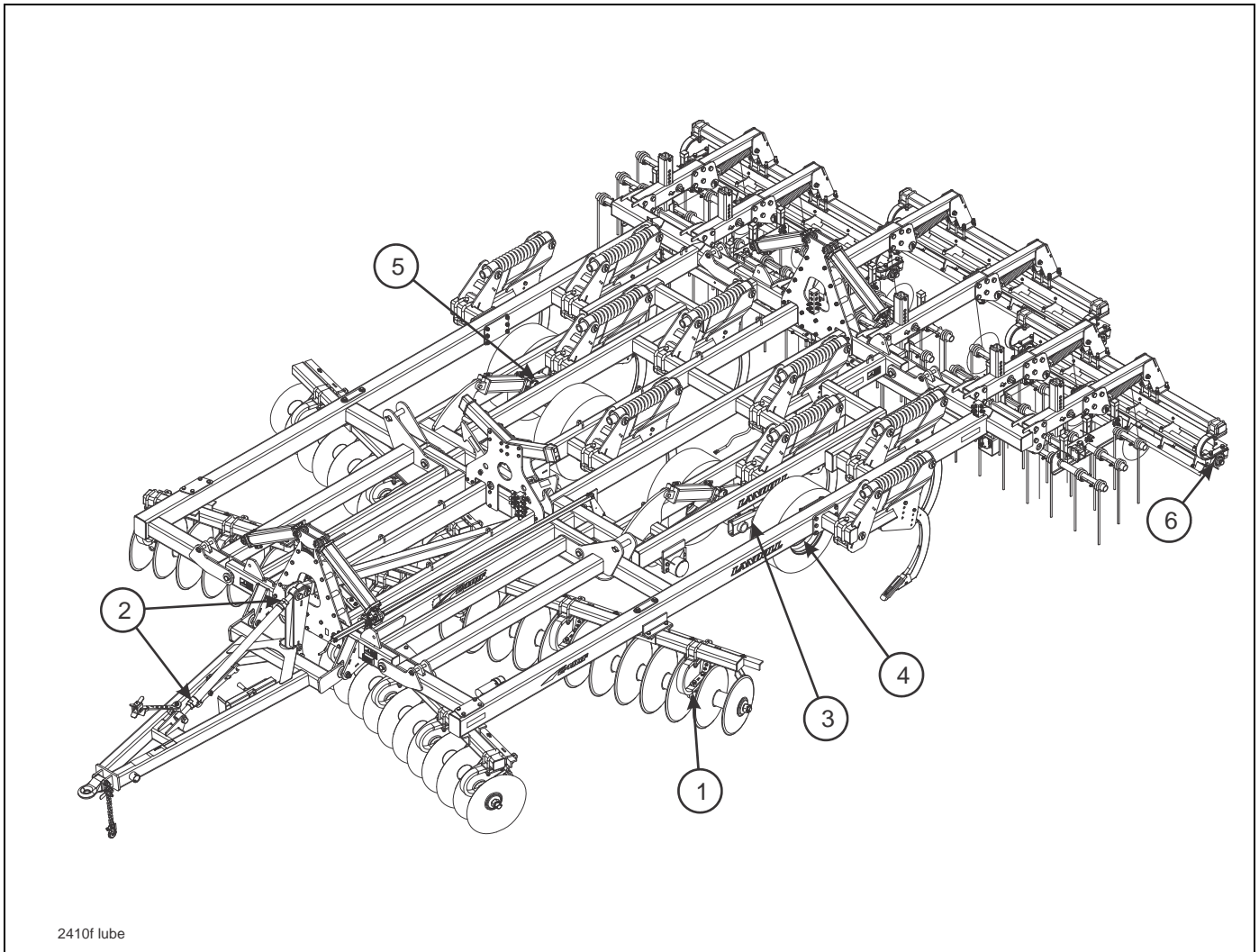

Figure 4-11: Lubrication Schedule

LUBRICATION TABLE			
ITEM	DESCRIPTION	NO. OF LUBE POINTS	INTERVAL (Hours Unless Stated)
1	Disc Gang Bearings	1 each	10
2	Radius Rod	2	50
3	Walking Tandem Hubs	1 each	50
4	Wheel Hubs	1 each	50
5	Lift Cylinder Rod Block	1 each	50
6	Reel Bearings	1 each	10

Table 4-1: Lubrication Table

### Lubrication Maintenance

1. **Table 4-1** specifies the lubrication points and intervals on the 2410F Weatherproofer I. Proper maintenance of your machine will, under normal operating conditions, help to keep it operating at or near its peak performance for an extended period of time. Proper maintenance is also a condition of keeping your warranty in good status (**See Figure 4-11.**)
2. When lubricating the Weatherproofer I, SAE multi-purpose EP grease, or EP grease with 3-5% molybdenum sulfide is recommended. Wipe soil from fittings before greasing. Replace any lost or broken fittings immediately.
3. Disc gang bearings are equipped with triple-lip seals that will let grease pass and not harm the seal. Regular lubrication will maintain a full grease cavity and help purge any contaminants. Grease the bearings before long periods of storage to prevent moisture buildup within the bearing cavity.
4. Wheel seals and walking tandem seals, when properly installed, will allow grease to pass without harm to seals. Regular lubrication will extend service life, particularly in severe operating conditions.
5. The Weatherproofer I is equipped with maintenance-free bearings in the lifts and leveler. These areas require no lubrication.

### Storage

1. The service life of the Weatherproofer I will be extended by proper off-season storage practices. Prior to storing the unit, complete the following procedures:
  - a. Completely clean the unit.
  - b. Inspect the machine for worn or defective parts. Replace as needed.
  - c. Repaint all areas where the original paint is worn off.
  - d. Grease all exposed metal surfaces of shanks, points and discs.
  - e. Apply a light coating of oil or grease to exposed cylinder rods to prevent them from rusting.
  - f. Lubricate each point of the machine as stated in **“Lubrication Maintenance” on page 4-10.**
2. Store the unit in a shed or under a tarpaulin to protect it from the weather. The ground tools and tires should rest on boards, or some other object, to keep them out of the soil.

**Notes:**

Page Intentionally Blank

## Troubleshooting Guide

The Troubleshooting Guide, shown below, is included to help you quickly locate problems that can happen using your 2410F Weatherproofer I. Follow all safety precautions stated in the previous sections when making any adjustments to your machine.

PROBLEM	PROBABLE CAUSE	SOLUTION
UNEVEN DEPTH	Unit not level when under power in the field	Level unit front to rear (See “Leveling (Front-to-Rear)” on page 4-4.)
	Excessive disc gang depth or down pressure	Reduce machine depth.
	Tire pressure too low	Check inflation.
	Unit not level front to rear	Adjust unit to be level.
UNIT SIDE DRAFTS OR MOVES SIDE TO SIDE	Lift wheels not carrying enough weight	Adjust depth stop and raise implement.
	Unit not level front to rear	Adjust unit to be level.
SHANKS PLUGGING WITH RESIDUE	Unit not level	Level machine (See “Leveling (Front-to-Rear)” on page 4-4.)
	Discs not cutting residue	Adjust machine depth.
SHANKS NOT PENETRATING	Unit not level	Level unit front to rear (See “Leveling (Front-to-Rear)” on page 4-4.)
	Points worn	Install new points.
WHEEL BEARING FAILURE	Triple-lip seals not installed correctly	Install seals with the lips pointing outward away from the hub.
DISC BLADES LOOSE AND/OR SHEARING ROLL PIN	Gang not tightened properly	Retighten gang shafts to 1200-1500 ft-lbs. If gangs have ran loose, gangs may require disassembly to remove soil to properly torque gang shafts. Replace any worn components, shafts/spools, etc.
HYDRAULIC - ENTIRE UNIT SETTLING	Depth stop valve not working	Repair valve
DISC GANG PLUGGING	Operating depth too deep	Raise unit.
	Conditions too wet	Wait until conditions more favorable.
DISC GANG WILL NOT TURN OR PUSHES SOIL	Depth set too deep for loose or wet conditions	Raise implement or wait until conditions are more favorable.
	Gang bearing failure	Replace bearing

Notes:







**Intertek**

Equipment from Landoll Corporation is built to exacting standards ensured by ISO 9001 registration at all Landoll manufacturing facilities.

## Model 2410F Weatherproofer 1 Operator's Manual

Re-Order Part Number F-735-0114

### **LANDOLL CORPORATION**

1900 North Street

Marysville, Kansas 66508

(785) 562-5381

**800-428-5655 ~ WWW.LANDOLL.COM**



Copyright 2010. Landoll Corporation

"All rights reserved, including the right to reproduce this material or portions thereof in any form"