



SUMMER PRODUCTS



**A LINE THAT
DELIVERS RESULTS!**

**BUILT TO
LAST**



OUR SUMMER PRODUCTS



Throughout the years we have helped farmers accomplish more work and be more productive by developing several innovative products.

The original rock bucket is a key example. No one has designed a better bucket to pick up all sizes of rocks, roots or debris. It is by far the most rugged and durable bucket on the market.

For more extensive field conditions, we've developed a complete range of rock rakes designed to move rocks and roots into a windrow for easier handling.

Land leveling has become an important aspect of land and crop management. At SHoule, we offer a wide range of models to help farmers in all sorts of applications. From small 2WD tractors to big 4WD's we have the right size and fit. Simply choose between 5 models from 8 to 24 feet (2.43 - 7.34 m) wide.

For cleaning ditches and improving field drainage, you have a choice of SHoule ditchers to choose from.

Land management is not complete unless you have a tool to handle trees. You can choose from our selection of tree shear models that fit most tractors, skid steer loaders, telehandlers or mini-excavators. You can cut trees or limbs up to 16 inches (40 cm) in diameter.

Finally, help clean branches, roots and debris using our heavy duty grapples mounted on our rock buckets.

TABLE OF CONTENTS

ROCK BUCKETS & GRAPPLES 4

**ATTACHMENTS FOR
ROCK BUCKETS 9**

ROCK RAKES 12

DITCH BLADES 20

BOX BLADES 21

LAND LEVELERS 22

PULL TYPE GRADERS 28

SILAGE BLADES 29

TREE SHEARS 30



BB, B, HB & SHB SERIES

useable for rocks, roots and debris

SHoule rock and material buckets are simply THE BEST on the market. With unmatched tips and lip design and high quality steel structure, we ensure you have the most robust tool to accomplish your work.

The tips are shaped according to the load distribution, and only a cast design could allow it. High carbon steel with chromolybdene provides a level of resistance no commercial steel rock bucket can match. In addition, their specially designed profile offers a stopper that allows for more volume capacity by keeping rocks from tumbling back. We have such confidence in our product that we offer a limited lifetime warranty on tips.

Our focus is not only on buckets, we also insure that our attaching brackets have the right angle that matches your OEM equipment.

It is clear that our rock buckets are not like any other one on the market and because we believe that our customers deserve the best, we have put the engineering and attention to details to make our rock buckets highly productive tools.

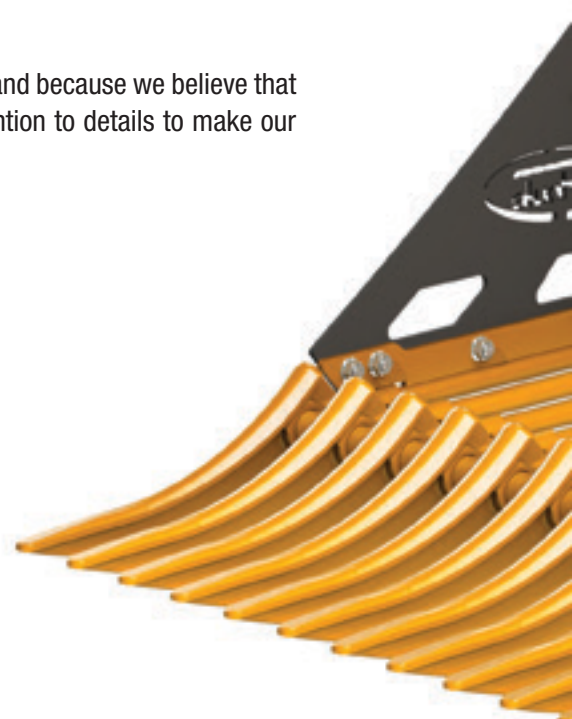

Industry Standards vs. SHoule Model Strength and Side Load



The cast steel tips offer **75%** More resistance to wear



When compared to the industry standard, SHoule's new tip with 1 1/4" (3.2 cm) steel rod is 98% stronger for vertical and side loads. Even more impressive is the tip with 1 1/2" (4 cm) rod that jump to 173% stronger on vertical loads and 144% stronger on side loads.



The industry standard tips are shaped with the rod ends which bend over time.



SHoule's model tips are made of cast steel that will not bend or break even under the most rigorous conditions.

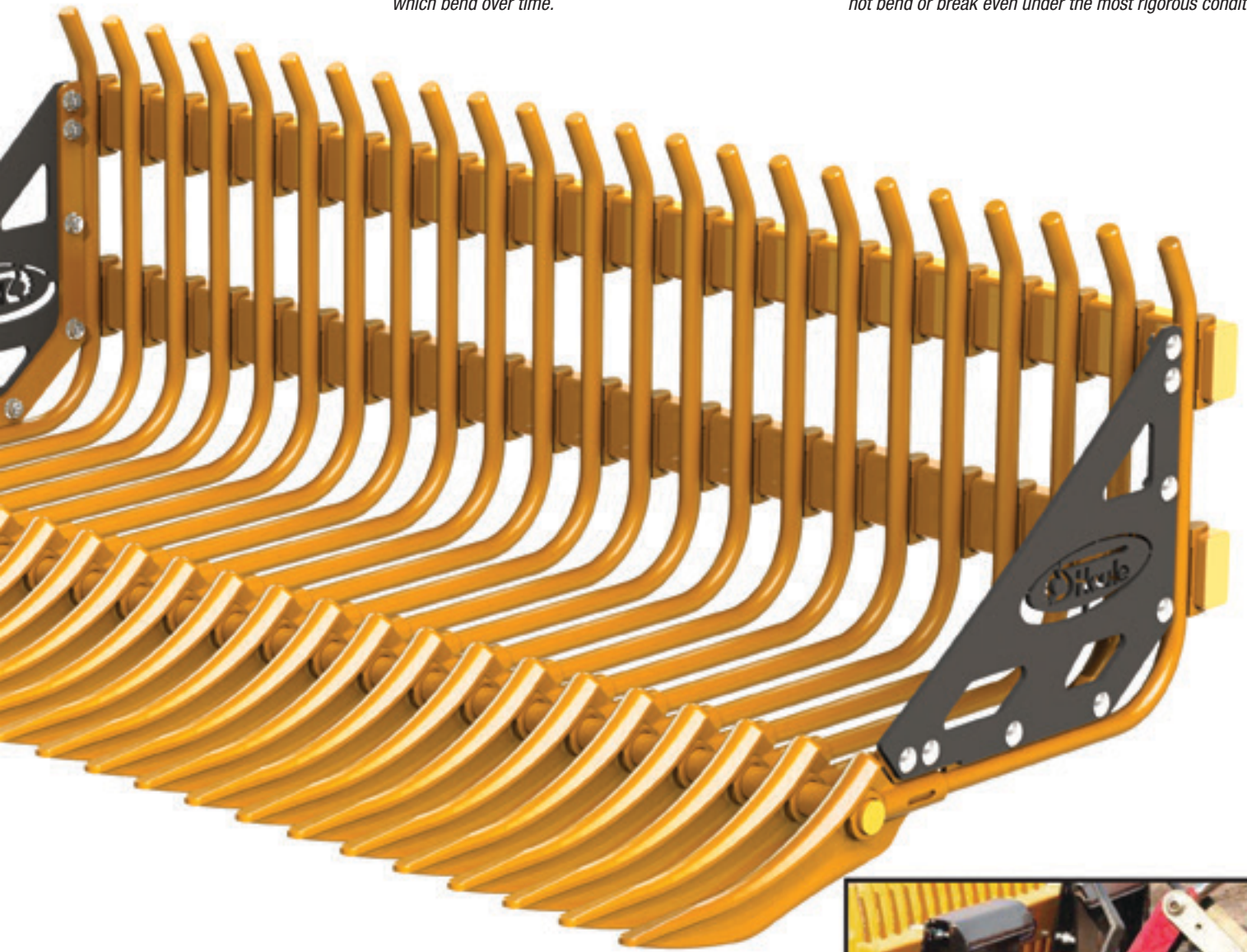

Attaching brackets are designed to respect the original manufacturer's designed angles.

BBW, BB, B and HB SERIES

30 to 200 HP (22-150 KW)



The BBW and BB Model buckets are ideal for picking up rocks and roots on the surface of the ground.

Tine Diameter: 1.125" (28 mm)
Space Between Tines:
 BBW Series: 2.5" (64 mm) • BB Series: 1.75" (45 mm)
Height: 24.75" (63 cm). **Depth:** 34" (87 cm)
Tensile Strength: 101,250 lb (46 000 kg)



The B Model rock bucket is designed to pick up rocks and roots at ground surface. With care, it can also be used for light digging.

Tine Diameter: 1.25" (32 mm)
Space Between Tines: 2.5" (64 mm)
Height: 24.75" (63 cm). **Depth:** 45" (114 cm)
Tensile Strength: 112,500 lb (51 000 kg)

The HB Model bucket will scoop rocks that lay on the surface of the ground, but can also dig up medium sized rocks. To provide the most leverage, simply position the fork so it is centered near the rock you wish to unearth.

Tine Diameter: 1.5" (38 mm)
Space Between Tines: 3" (76 mm)
Height: 24.75" (63 cm). **Depth:** 41.25" (105 cm)
Tensile Strength: 135,000 lb (61 000 kg)

BBW Series - 30 to 60 HP (22-45 KW)

MODEL	WIDTH in / cm	WEIGHT lb / kg	NO OF TINES
BB-4W	49 / 124	400 / 182	14
BB-5W	60 / 152	477 / 217	17
BB-6W	75 / 191	585 / 266	21
BB-7W	86 / 218	665 / 302	24

BB Series - 30 to 60 HP (22-45 KW)

MODEL	WIDTH in / cm	WEIGHT lb / kg	NO OF TINES
BB-4	47 / 120	480 / 218	17
BB-5	62 / 160	600 / 272	21
BB-6	70 / 178	705 / 320	25
BB-7	82 / 210	780 / 354	29

B Series - 60 to 100 HP (45-75 KW)

MODEL	WIDTH in / cm	WEIGHT lb / kg	NO OF TINES
B-5	58 / 147	581 / 264	16
B-6	70 / 178	760 / 345	19
B-7	81 / 206	875 / 397	22
B-8	92 / 234	990 / 450	25

HB Series - 85 to 200 HP (63-150 KW)

MODEL	WIDTH in / cm	WEIGHT lb / kg	NO OF TINES
HB-5	61 / 155	705 / 320	14
HB-6	70 / 178	820 / 372	16
HB-7	88 / 223	990 / 450	19
HB-8	97 / 246	1110 / 504	22
HB-9	110 / 279	1375 / 624	25

GP SERIES

for BB to HB rock buckets, 6 to 9 ft (1,8 - 2,7 m)



The GP-10 is the result of continuous improvements of our products. It is adaptable to all our rock buckets from 7' to 9' (2.13 - 2.7 m). Made of double steel frame and chromolybdene teeth, the GP-10 is tough and durable. It is designed for use with tractors, skid steer loaders as well as telehandlers.

GP-10 Model

DESCRIPTION	WEIGHT lb / kg
2 Hydraulic cylinders 2" (51 mm) dia. (hose to tractor not supplied) C/W 4 chromolybdene steel teeth	625 / 284

OPTIONS

Extra tooth

Double Action Kit

For grabbing uneven objects. Bracketery & Hydraulic fittings.



SHB SERIES & SGP Grapple

200 HP + (145 KW +)



The SHB Model bucket is built for wheel loaders or payloaders, and can also be mounted on any large backhoe loader. Each tine is reinforced with a high strength steel plate for maximum durability. With the strength of this bucket, you can dig up and move any kind of debris.

- Tine Diameter:** 1.75" (45 mm)
- Space Between Tines:** 4" (100 mm)
- Height:** 32" (81 cm). **Depth:** 44.25" (112 cm)
- Tensile Strength:** 157,500 lb (71 450 kg)

Especially designed for heavy duty work the SGP-10 Series grapple is made to be used with the SHB rock bucket. The SGP-10 is equipped with two powerful 2.5" (64 mm) hydraulic cylinders. It is built with the same components as the GP version but heavier. Adapted for industrial loaders, mini-excavators and other loading equipment such as telehandlers.



SHB Series - more than 200 HP (145 KW+)

MODEL	WIDTH in / cm	WEIGHT lb / kg	NO OF TINES
SHB8	100 / 254	2075 / 943	18
SHB9	112 / 285	2205 / 1002	20

SGP-10 Model

DESCRIPTION	WEIGHT lb / kg
Grapple forks for SHB, 8' & 9' (2.1-2.7 m) 2 Hydraulic cylinders 2.5" (64 mm) dia. (hose to tractor not supplied) C/W 4 chromolybdene steel teeth	700 / 317

OPTIONS

Extra tooth

Double Action Kit

For grabbing uneven objects. Bracketery & Hydraulic fittings.

QUICK ATTACH

FRONT END LOADER FOR AGRICULTURAL TRACTORS



ALO600



Case IH L300, 510, 520



Hardy

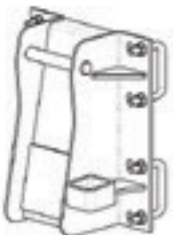

JD 240, 245, 260, 265

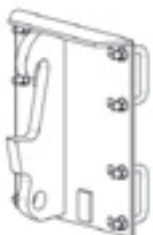

JD 244J

PRODUCT NO	MODEL	WEIGHT lb / kg	
IN-20E12	UNIVERSAL Q.A (1" DIA. PINS)	76/35	
IN-20E35	UNIVERSAL Q.A (1 1/2" DIA. PINS)	76/35	
IN28-00004	ALLIED 595 QA	105/48	
IN28-00005	ALLIED	82/37	
IN28-00003	ALLIED 795	153/69	
IN28-00002	ALLIED 895	115/52	
IN41-00001	ALLIED EURO 2595	136/62	
IN20-00002	ALO 300, 400, 600, 700, 900	115/52	
IN20-00004	ALO (SHB)	365/166	
IN02-00005	CIH L300, 510, 520	214/97	
IN20-00002	CASE LX 162 - 172, L400 - L750, LX156 QA	114/52	
IN22-00003	FNH 16-17 LA, 32-33 LA QA	125/57	
IN22-00003	FNH 46LB, 52LA-LB-LC QA	125/57	
IN25-00002	FNH 7312-14, 7411-12-13, 7511	153/69	
IN25-00001	FNH 9030, 276, 7414, 256	160/73	
IN03-00004	FNH TV140	194/88	
IN24-00001	HARDY	145/66	
IN02-00004	INTERNATIONAL 650	117/53	
IN01-00031	JD 145 DIRECT	109/49	
IN01-00014	JD 240, 245, 260, 265	109/49	
IN01-00043	JD 400X	89/40	
IN01-00019	JD 410, 419, 430, 440, 460	100/45	
IN01-00040	JD 480H GLOBAL	314/143	
IN01-00019	JD 520, 521, 540, 541, 542	100/45	
IN01-00013	JD 620, 640, 720, 725, 740, 741	160/73	
IN01-00034	JD 746 QA	180/82	
IN01-00022	JD 840	360/164	
IN01-00032	JD 840 (SHB)	425/193	
IN04-00003	KUBOTA LA 402 DIRECT	83/38	
KUM1250	KUBOTA M1250, M7030	95/43	
IN05-00006	MASSEY 1036, 1038	95/43	
IN05-00005	MASSEY 1070, FENDT	133/60	
IN03-00011	NH B59B DIRECT	139/63	

QUICK ATTACH

SKID STEER LOADERS

PRODUCT NO	MODEL	WEIGHT lb / kg	
IN22-00003	ASV RC50, RC60 QA	125/57	
IN01-00021	JD 280	157/71	
IN03-00003	NH L454/55, L425	183/83	
IN03-00007	NH L555	113/51	
IN22-00009	SKID STEER FLAT PLATE	103/47	
IN22-00003	SKID STEER QUICK ATTACH BRACKETS	125/57	

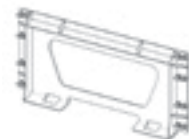

Skid Steer plate

TELEHANDLERS

PRODUCT NO	MODEL	WEIGHT lb / kg	
IN01-00020	JD 3400, 3800	200/91	
IN06-00001	MERLO 26,6 ASS	235/107	
IN06-00003	MERLO ZM 2	286/130	
IN13-00016	JCB 506, 508	101/46	
IN13-00006	JCB 524-50	106/48	
IN13-00005	JCB 524	352/160	
IN13-00009	JCB 530B	247/112	
IN13-00007	JCB 530B (SHB)	255/116	
IN13-00013	JCB 524-50 (SHB)	161/73	



Skid Steer plate



JRB 416

INDUSTRIAL LOADERS, BACKHOES ETC.

PRODUCT NO	MODEL	WEIGHT lb / kg	
IN02-00019	CASE 580E	142/65	
IN02-00014	CASE 580L DIRECT	174/79	
IN02-00012	CASE 580M DIRECT	179/81	
IN02-00011	CASE 721B	321/146	
IN11-00001	CAT 950	210/95	
IN11-00021	CAT IT14/24/28	250/113	
IN11-00014	CAT IT28 (SHB)	456/207	
IN11-00015	CAT IT416/420/424	273/124	
IN11-00022	CAT 936F/938F/938G (SHB)	480/218	
IN11-00020	CAT IT950/962/966/972 (SHB)	482/219	
IN11-00017	CAT 980B (SHB)	789/358	
IN13-00001	JCB 210	162/74	



Cat IT28

QUICK ATTACH

INDUSTRIAL LOADERS, BACKHOES ETC. (continued)



JD 544

IN13-00004	JCB 426 HT	345/157	
IN01-00029	JD 244E	237/108	
IN01-00015	JD 244J EURO	132/60	
JD244JSHB	JD 244J EURO (SHB)	140/64	
IN01-00025	JD 310G/410G QA	190/86	
IN01-00060	JD 310 DIRECT (PLAQUE)	262/119	
IN01-00046	JD 444E DIRECT (SHB)	209/95	
IN01-00044	JD 444J (SHB)	307/139	
IN01-00008	JD 544 (SHB)	200/90	
IN01-00030	JD 544	180/82	
IN04-00006	KUBOTA R520/R410/R420/R510	235/107	
IN05-00003	MASSEY 60 TL	170/77	
IN16-00001	VOLVO BL71	325/148	
IN19-00004	VOLVO L120C	348/158	
IN16-00010	VOLVO L50/L70	385/175	



JCB 426HT

INDUSTRIAL ADAPTORS



JRB 416

PRODUCT NO	MODEL	WEIGHT lb / kg	
IN21-00007	JRB 416	276/125	
IN21-00003	JRB 416 (SHB)	311/139	
IN21-00002	JRB DEERE "E" SERIES	233/106	
IN09-00004	EDF	187/85	
IN09-00009	EDF (SHB)	377/171	
IN21-00005	JRB 418 (SHB)	435/186	
IN26-00002	VALLÉE (SHB)	543/246	

Many other model attachments available or can be custom built.
Inquire about the model you need for availability.

WD, PWD, SRR & SWD SERIES

useable for rocks, roots and debris

Whichever size rake you choose, we insure the same product quality. Whether you purchase a three point mounted or pull type version, all rakes come standard with bolt on, reversible and replaceable teeth made of RT-400 steel which is 4 times stronger than market standards. All mechanical rakes are protected with a slip clutch system while the hydraulic version is pressure regulated.

All our frames are of the highest grade material to support greater shocks and loads in rough field conditions. They are also driven by heavy duty double chains (single for WD-6) located in a sealed drive case for complete dust and rock protection.

WD-10H:

Unlike the standard WD models, the WD-10H rock rake is powered directly by the tractor's hydraulic system. It also includes a 25 degree hydraulic swivel, enabling it to be perpendicular to the tractor if desired.

PWD-10:

In addition to the above standard features, the PWD-10 also includes a tilt system on the rear wheel to adjust to ground contour.

SRR-15:

Bigger rakes require additional features such as the suspended drum that follow ground contour and absorb shocks from heavier rocks. Adjustable working angle and shield protection are other key standard features of the SRR-15. For ease of maintenance, the dual drive chain is adjustable via an eccentric tensioning system. Transport mode is set manually within minutes.

SWD-15:

Our top of the line model. It has a longer drum and bigger drive bearings. Working angle is adjustable and transport mode is achieved hydraulically.

Features:

1. Pull type or 3 point hitch
2. Hydraulic transport system
3. Heavy duty frame
4. Flotation system (drum)
5. Protective shields
6. Sealed chain case
7. Dual chain
8. Multiple disc slip clutch
9. Heavy duty teeth replaceable and reversible

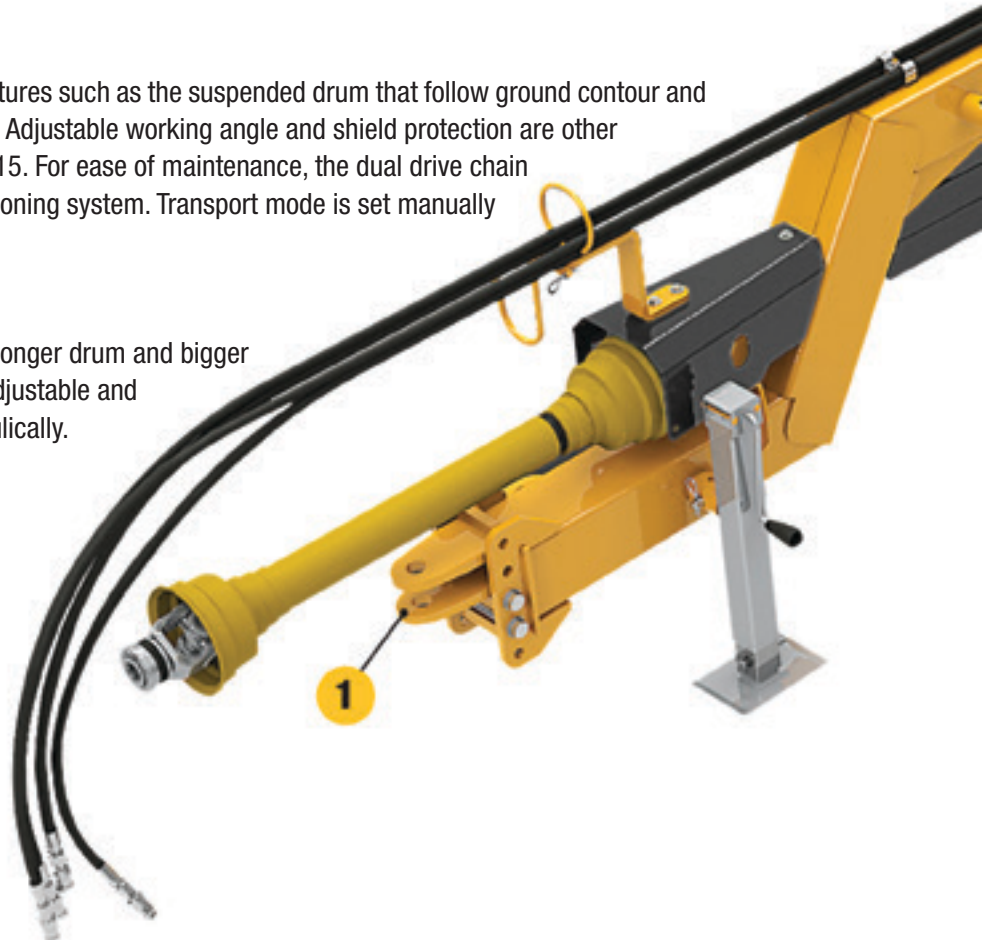

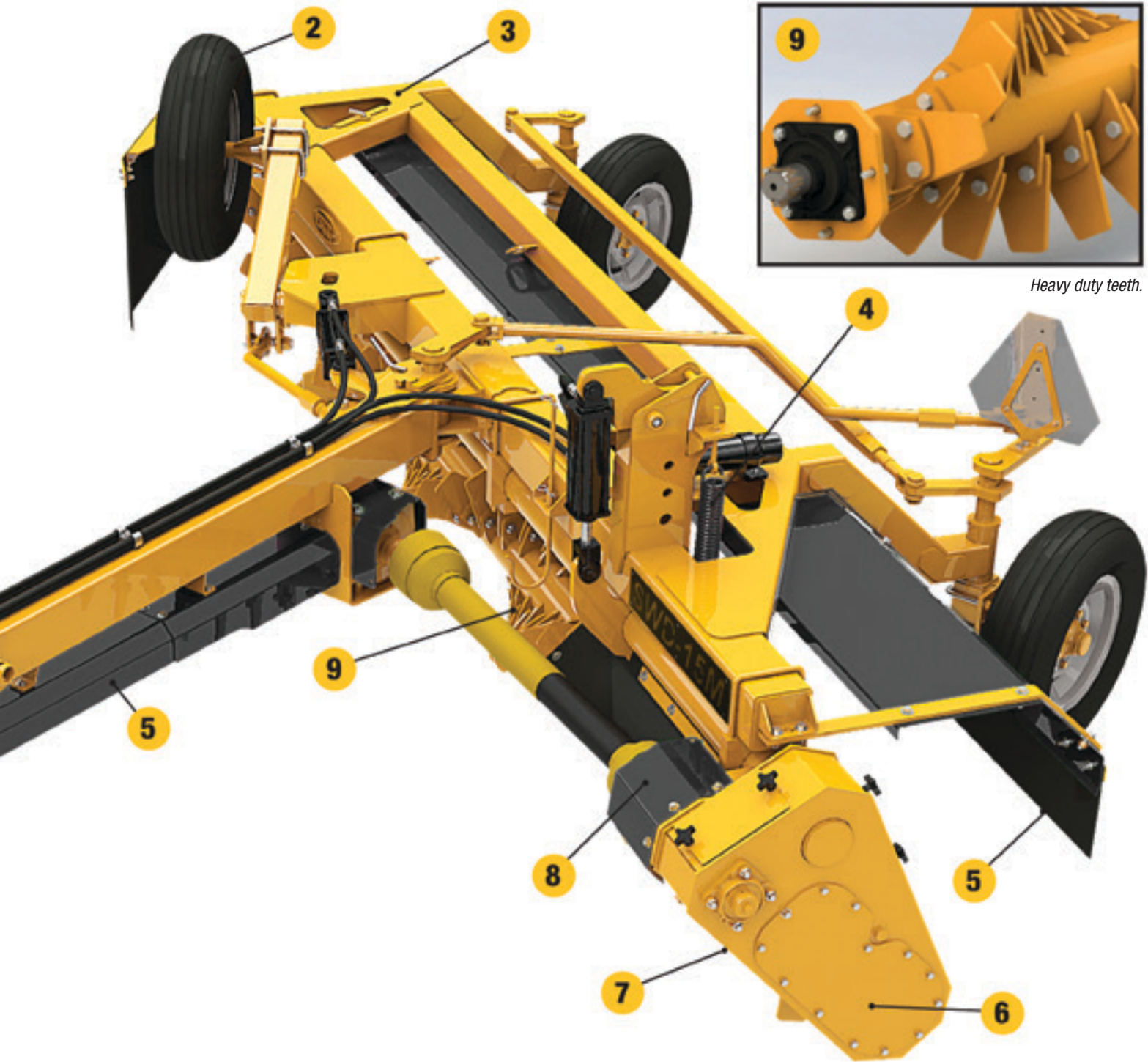

Heavy duty teeth.



Dual chain.



Multiple disc slip clutch.

WD SERIES

Standard 3 point hitch models, PTO driven



The WD-6 and WD-10B rock rakes are made to move rocks and roots into windrows making them easier to collect.

Equipment Specifications:

Tires:

- WD-6 : 16.5" x 6.5" (419 x 165 mm)
- WD-10B : 18.5" x 8.5" (470 x 206 mm)

Able to pivot 360° allows for greater flexibility and maneuverability

Hookup: 3 point hitch mounting system

Drop Box: Chain, gears and bearings in sealed oil bath

Protection: Slip clutch

Tooth Type: RT-400 steel replaceable and reversible, 4x stronger than regular steel

Transport conversion : None

Working Width:

- WD-6: 5' 2" (1.6 m)
- WD-10: 8' 8" (2.7 m)



WD Series (standard)

MODEL	WIDTH ft / m	WEIGHT lb / kg	RECOM. HP HP / KW
WD-6	7.3 / 2.2	1150 / 522	40-60 / 30-48
WD-10B	11.3 / 3.5	1850 / 839	65-125 / 48-93

WD SERIES

Hydraulic models, 25° swivel
front or rear mounted



Rear installation

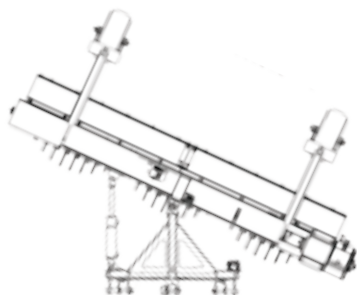
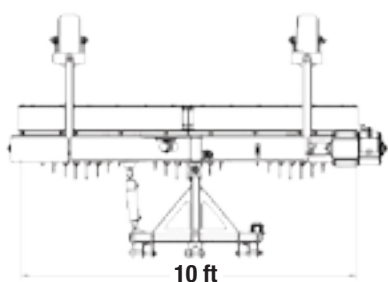

The WD-10H rock rake is powered directly by the tractor's hydraulic system.

It can be installed in front on a SKID STEER loader, or front or rear mounted on a 3 point hitch.

This rock rake has a 25 degree hydraulic swivel, enabling it to be perpendicular to the tractor if desired.

The tractor's hydraulic system requirements are a flow between 10 and 16 GPM (37.85 to 6-.56 l/m), with a maximum pressure of 3000 psi (207 bars).

Equipment Specifications:

Tires: 18.5" x 8.5" (470 x 206 mm)

Hookup: SKID STEER or 3 point hitch

Drop Box: Chain, gears and bearings in sealed oil bath

Protection: Pressure relief valve

Tooth Type: RT-400 steel replaceable and reversible

Working Width: 10' (3.05 m)

WD Series (hydraulic drive, 25° swivel)

MODEL	WIDTH ft / m	WEIGHT lb / kg	RECOM. HP HP / KW
WD-10H	11.4 / 3.47	2100 / 953	65+ / 49+

Attachment Type

3 POINT HITCH	
SKID STEER	

Assembly Options

PARTIALLY ASSEMBLED	
FRONT OR REAR MOUNTED ASSEMBLY	

Front installation



on SKID STEER



PWD SERIES

pulled model



The PWD-10 rock rake is designed to dig and move rocks and roots into a windrow making them easy to collect.

Equipment Specifications:

Tires: 11L/15

Hookup: Pull type

Drop Box: Chain, gears and bearings in sealed oil bath

Protection: Slip clutch

Tooth Type: RT-400 steel replaceable and reversible, 4x stronger than regular steel

Transport conversion : Manual

Working Width: 8' 8" (2.7 m)



PWD Series

MODEL	WIDTH ft / m	WEIGHT lb / kg	RECOM. HP HP / KW
PWD-10	11.3 / 3.5	2500 / 1134	65-125 / 48-93

SRR SERIES

manual transport conversion



SRR-15M

Mechanical version. Driven with a driveshaft connected to the tractor's PTO.



SRR-15T

Independant hydraulic system. The auxiliary pump is driven with a driveshaft connected to the tractor's PTO. The rake is provided with a reservoir and an oil cooler. The oil from the tractor does not flow into the rake's system.



SRR-15H

Fully hydraulic. The rake is driven by the tractor's hydraulic system. There is no hookup to the PTO. The tractor's oil circulates in the rake's system. The tractor must provide between 16 gpm and 32 gpm @ 3000 psi.



The SRR-15 is designed to adapt to 65-125 HP (49-93 KW) tractors. It digs and moves rocks and roots to form a windrow making them easy to pick up. Available in 3 versions.

Equipment Specifications:

- Tires:** 11L/15
- Hookup:** Pull type
- Drop Box:** Chain, gears and bearings in sealed oil bath
- Protection:** Slip clutch or pressure relief for hydraulic drive
- Tooth Type:** RT-400 steel replaceable and reversible, 4x stronger than regular steel
- Working Width:** 13' (4 m)
- Transport Conversion :** Manual
- Other:**
 - Width of transport 8' (2.43 m)
 - Multiple guards
 - Flotation system



SRR Series

MODEL	WIDTH ft / m	WEIGHT lb / kg	RECOM. HP HP / KW
SRR-15M	15.8 / 4.8	4275 / 1940	65-125 / 48-93
SRR-15T	15.8 / 4.8	4775 / 2170	65-125 / 48-93
SRR-15H	15.8 / 4.8	4275 / 1940	65-125 / 48-93

SWD SERIES

hydraulic transport conversion



The SWD -15 is designed to adapt to 65-125 HP (48-93 KW) tractors. It digs and moves rocks and roots to form a windrow making them easy to pick up. It is offered in 3 versions.

Equipment Specifications:

Tires: 11L/15

Hookup: Pull type

Drop Box: Chain, gears and bearings in sealed oil bath

Protection: Slip clutch (or pressure relief for hydraulic drive)

Tooth Type: RT-400 steel replaceable and reversible, 4x stronger than regular steel

Working Width: 13' 10" (4.2 m)

Transport Conversion : Hydraulic

Other:

- Width of transport 8' (2.43 m).
- Multiple guards
- Flotation system



SWD-15M



Mechanical version. Driven with a driveshaft connected to the tractor's PTO.

SWD-15T



Independent hydraulic system. The auxiliary pump is driven with a driveshaft connected to the tractor's PTO. The rake is provided with a reservoir and an oil cooler. The oil from the tractor does not flow into the rake's system.

SWD-15H



Fully hydraulic. The rake is driven by the tractor's hydraulic system. There is no hookup to the PTO. The tractor's oil circulates in the rake's system. The tractor must provide between 16 gpm and 32 gpm @ 3000 psi.

SWD Series				
MODEL	WIDTH ft / m	WEIGHT lb / kg	RECOM. HP HP / KW	
SWD-15M	16.7 / 5.1	4500 / 2040	65-125 / 48-93	
SWD-15T	16.7 / 5.1	5000 / 2273	65-125 / 48-93	
SWD-15H	16.7 / 5.1	4500 / 2040	65-125 / 48-93	

DRR SERIES

double auger



The DRR-30H is a double auger rock rake designed for major chores. With two 14' floating augers, the unit unfolds to an angle of 120 degrees to achieve a total working width of 27 feet. The unit has a 30 inch central area allowing the formation of a single rock swath. Hydraulic drive activated by tractor PTO, protected with overflow caution valve and cooled with thermostatic bypass valve. Comes with hydraulic depth control.

Equipment Specifications:

Tires: Rear: 16.5 x 16.1 (2x) / Front: 11L-15 (4x)

Hookup: Pull type (category 2 or 3)

Drop Box: Chain, gears and bearings in sealed oil bath

Protection: Pressure relief valve

Tooth Type: RT-400 steel, replaceable and reversible

Working Width: 27'

Transport Conversion : Hydraulic

Other:

- Transport width: 10' 2" (3.10 m)
- Multiple guards
- Flotation system

DRR Series

MODEL	WIDTH ft / m	WEIGHT lb / kg	RECOM. HP HP / KW
DRR-30H	35 / 10.66	13 500 / 6124	80+ / 60+



LFA SERIES



The LFA is equipped with 4 articulations which gives it high maneuverability. The 3 point hitch bracket of the LFA is designed to accept category 2 or 3 systems. With the rear wheel module (optional), the LFA can be transformed into a small land leveler. Side panels can also be added.



LFA Series

MODEL	DESCRIPTION	WEIGHT lb / kg	
LFA-08	3-pts hitch rear blade ditcher, 8 ft	1825 / 828	
LFA-10	3-pts hitch rear blade ditcher, 10 ft	2020 / 916	

OPTIONS

- Side panel option
- Back wheel option

HLS & HLL SERIES



HLS Series

MODEL	WEIGHT lb / kg	RECOM. HP HP / KW
HLS-08	720 / 327	30-50 / 22-37
HLS-10	800 / 363	40-70 / 30-52
HLS-12	880 / 399	60-80 / 45-60

The HLS land scraper is ideal for moving soil or to level roads, yards and fields. It is also great for backfilling at building sites, feedlots or arenas.

Blade Height: 30" (76 cm)

OPTIONS

Post for GPS receiver

Post for LASER receiver

Kit of 2 Scarifying Teeth

Recommended number of kits:

2x for HLS-08

3x for HLS-10

4x for HLS-12



HLL Option
Premium Level Indicator

HLL Series

MODEL	WEIGHT lb / kg	RECOM. HP HP / KW
HLL-08	1850 / 840	40-110 / 30-82
HLL-10	1875 / 850	60-110 / 45-82
HLL-12	1985 / 900	80-110 / 60-82

The HLL is designed to be used with utility tractors from 40 to 110 HP (30-82 KW). Best in its class in terms of strength and durability, the HLL box scraper can level almost any type of surfaces from gravel roads to fields. Tilt and height functions are controlled by 3 cylinders.

Blade Height: 30" (76 cm)

OPTIONS

Scarifying teeth kit 8' (2.4 m)

Scarifying teeth kit 10' (3.0 m)

Scarifying teeth kit 12' (3.7 m)

Premium Level Indicator

Post for GPS receiver

Post for LASER receiver

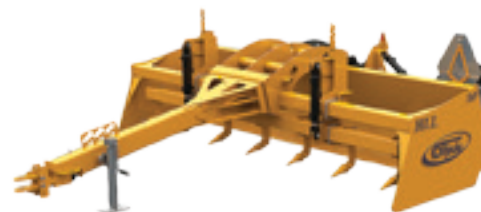

LNS, LN & SLN SERIES

Seed bed preparation is the most critical step to assure optimal yields. The role of the land leveler is to level the ground by eliminating mounds and hollows. Dirt is moved to fill in depressions where water tends to accumulate and stagnate.

At SHoule, we have a complete range of land levelers that can help you accomplish this task. Our land levelers can be equipped with scarifying teeth designed to break hard ground surfaces. Options of a GPS or a laser post for precision work, agricultural or industrial tires mounted in tandem in order to reduce the machine's waddle, and a hydraulic tilting system to work ground along the ditches. All of these are just a few of the long list of features that can be ordered when purchasing our land levelers.

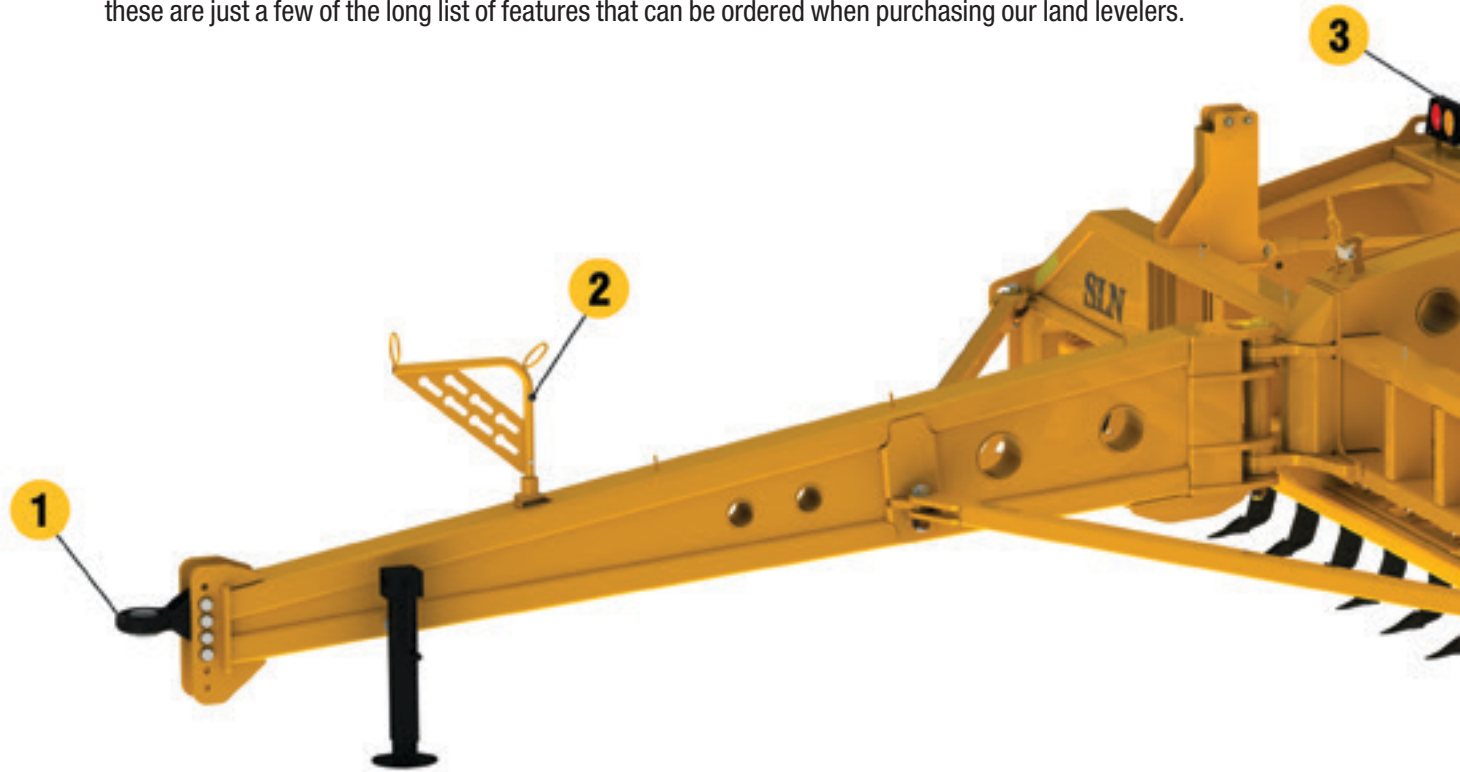

Options:

1. Multiple ISO attach systems available depending on the type of tractor.
2. Hydraulic hose support.
3. Taillight kit for road trips.
4. Laser or GPS post. Comes standard with basic guard rail
5. Carriage Lift Cylinder.
6. Cradle assembly: The frame is equipped with two hydraulic cylinders that can lift the blade approximately 20" (51 cm) above ground level.
7. A tilt system is available. This system can be installed either on the left hand, right or both sides at once. It allows the blade to tilt approximately 12" (30 cm).
8. The leveler is equipped with tires mounted in tandem using a flotation system to minimize the waddle. Used industrial tires are available at no extra cost (SLN models only).
9. High capacity hubs (5,000 - 12,000 - 16,000 lb / 2 250 - 5 500 - 7250 kg) depending on the model respectively LNS, LN or SLN, significantly reduce maintenance costs.
10. The land leveler has reversible hardened steel side cutters. Wit skid wear plates standard.
11. Stabilizing skid shoes are ideal for high speed finishing applications.
12. Hydraulically activated scarifying teeth system is available for breaking hard ground surface (up to 4" or 10 cm). Kit includes industrial grade teeth spread 18" (48 cm) apart that guarantee excellent ground penetration and breakage.

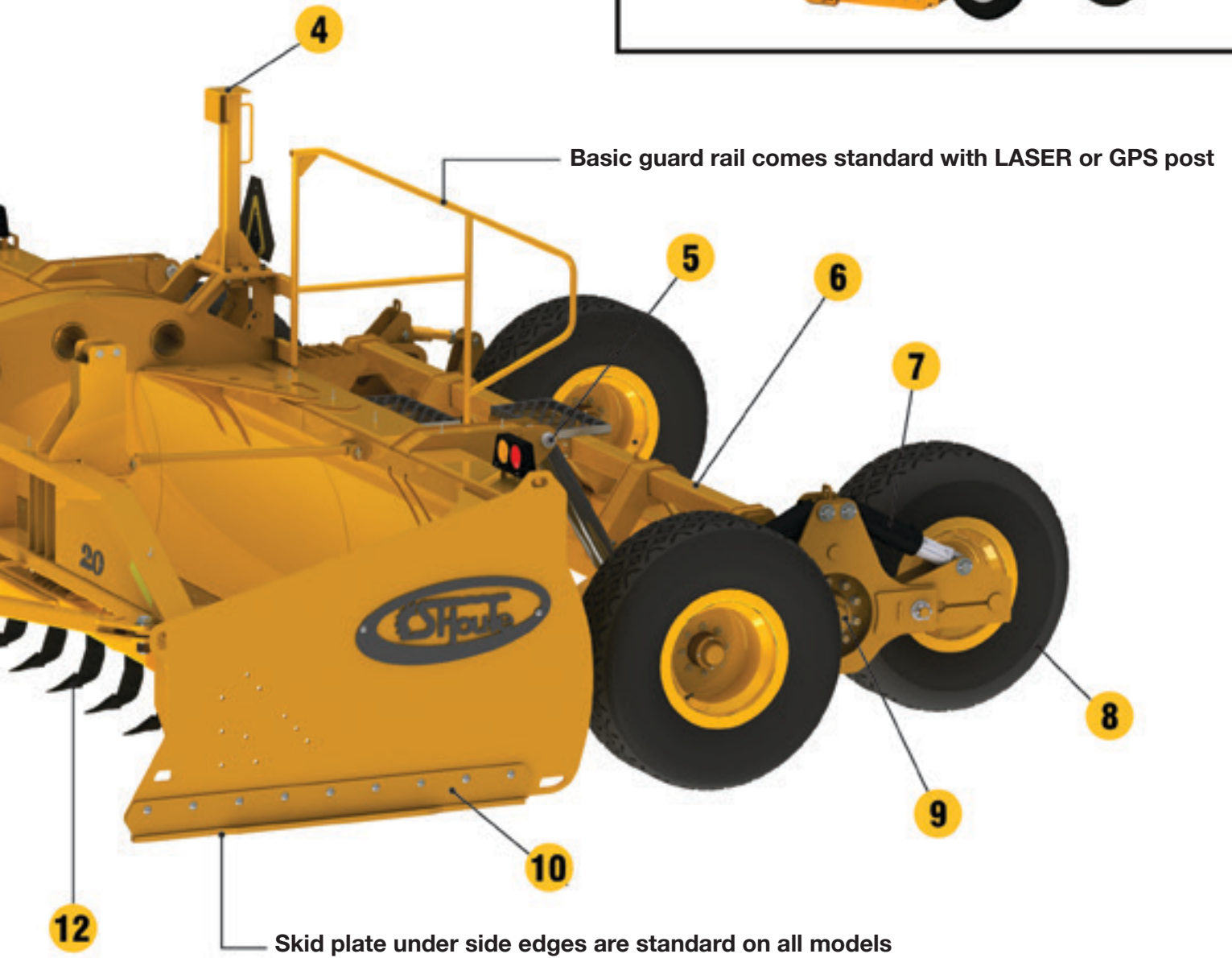

Maximum clearance

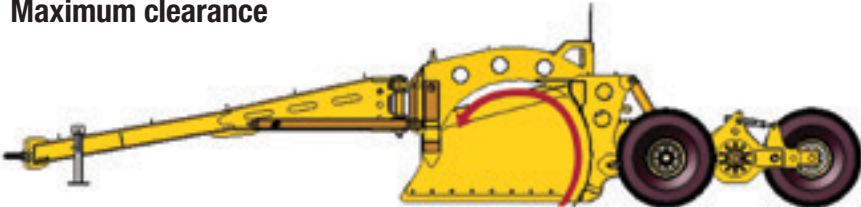

The unique design of our curved frame allows dirt to roll inside the basket thus increasing the capacity while preventing lifting of the unit.

LNS, LN and SLN SERIES

larger models comparison

LNS SERIES 75 to 125 HP (56-94 KW)



Available models

12 feet (3,7 meters)

14 feet (4,3 meters)

LN SERIES 100 to 250 HP (75-190 KW)



Available models

14 feet (4,3 meters)

16 feet (4,8 meters)

18 feet (5,5 meters)

LN SERIES with TRANSPORT KIT 100 to 250 HP (75-190 KW)



Available models

18 feet (5,5 meters)

SLN SERIES 300 HP + (225 KW +)



Available models

16 feet (4,8 meters)

18 feet (5,5 meters)

20 feet (6 meters)

24 feet (7,3 meters)

SLN SERIES with TRANSPORT KIT 300 HP + (225 KW +)



Available models

16 feet (4,8 meters)

18 feet (5,5 meters)

20 feet (6 meters)

24 feet (7,3 meters)

LNS & LN SERIES

LNS Series 75 - 125 HP • 56 KW to 94 KW (tires: 11L15, Wheels 15x8)



MODEL	DESCRIPTION	VOLUME ft ³ / m ³	WEIGHT lb / kg
LNS-12	Land Leveler 12' x 34" (3.7 m x 86 cm)	101 / 2,86	3400 / 1542
LNS-14	Land Leveler 14' x 34" (4.3 m x 86 cm)	118 / 3,34	3750 / 1700

OPTIONS

Light kit			
Post for GPS receiver		60 / 27	
Post for LASER receiver		70 / 32	
Articulated right tandem (tilt the blade up to 4 degrees)		+270 / 123	
Articulated left tandem (tilt the blade up to 4 degrees)		+270 / 123	
Articulated on both sides (right and left)		+530 / 241	
Scarifying teeth kit 12' (3.7 m)		463 / 210	
Scarifying teeth kit 14' (4.3 m)		489 / 222	

LN Series 100 - 250 HP • 75 KW to 190 KW (Tires: 12.5L15, Wheels 15x8)



Articulated left tandem LN

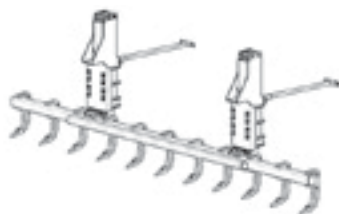

Scarifying teeth kit LN



Standard tire

Traction tire

MODEL	DESCRIPTION	VOLUME ft ³ / m ³	WEIGHT lb / kg
LN-14	Land Leveler 14' x 42" (4.3 m x 107 cm)	186 / 5,27	7415 / 3370
LN-16	Land Leveler 16' x 42" (4.8 m x 107 cm)	212 / 6,00	8115 / 3688
LN-18	Land Leveler 18' x 42" (5.5 m x 107 cm)	239 / 6,77	8224 / 3738
LN-18T	Land Leveler 18' x 42" (5.5 m x 107 cm) - with Transport Kit - width 13.5' (4.1m)	239 / 6,77	9380 / 4264

OPTIONS

Single or double attachment			
Traction tires (31 x 15.5 - 15 NHS)			
Agricultural Light kit (included on transport kit models)			
Post for GPS receiver		60 / 27	
Post for LASER receiver		70 / 32	
Articulated right tandem (tilt the blade up to 4 degrees)		+270 / 123	
Articulated left tandem (tilt the blade up to 4 degrees)		+270 / 123	
Articulated on both sides (right and left)		+530 / 241	
Bidirectional articulated left tandem		+301 / 137	
Bidirectional articulated right tandem		+301 / 137	
Scarifying teeth kit			
	14' (4.3 m)	1272 / 578	
	16' (4.8 m)	1316 / 598	
	18' (5.5 m)	1429 / 650	

SLN SERIES

SLN Series 300 HP and + • 225 KW and +

MODEL	DESCRIPTION	VOLUME ft ³ / m ³	WEIGHT lb / kg
SLN-16	Land Leveler 16' x 50" (4.9 m x 127 cm)	272 / 7,70	11,100 / 5045
SLN-18	Land Leveler 18' x 50" (5.5 m x 127 cm)	306 / 8,66	13,135 / 5970
SLN-20	Land Leveler 20' x 50" (6 m x 127 cm)	344 / 9,74	13,196 / 6000
SLN-24	Land Leveler 24' x 50" (7.3 m x 127 cm)	382 / 10,82	15,174 / 6900



Standard SLN land leveler



SLN land leveler with transport kit



SLN stabilizer skid shoe



Security access kit

SLN Series with TRANSPORT KIT 300 HP and + • 225 KW and +

MODEL	DESCRIPTION	VOLUME ft ³ / m ³	WEIGHT lb / kg
SLN-18-T	Land Leveler 18' x 50" (5.5 m x 127 cm)	272 / 7,70	14,839 / 6745
	- Transport width 16,2' (4,92 m)	306 / 8,66	
SLN-20-T	Land Leveler 20' x 50" (6 m x 127 cm)	344 / 9,74	15,247 / 6930
	- Transport width 16,2' (4,92 m)	382 / 10,82	
SLN-24-T	Land Leveler 24' x 50" (7.3 m x 127 cm)		16,823 / 7647
	- Transport width 16,2' (4,92 m)		

OPTIONS

Cat 4 attachment	
Agricultural Light kit (included on transport kit models)	
Safety access kit	217 / 98
Post for GPS receiver	60 / 27
Post for LASER receiver	70 / 32
Articulated right tandem (tilt the blade up to 4 degrees)	+402 / 183
Articulated left tandem (tilt the blade up to 4 degrees)	+402 / 183
Articulated on both sides (right and left)	+707 / 321
Bidirectional articulated left tandem	+430 / 195
Bidirectional articulated right tandem	+430 / 195
Scarifying teeth kit - SLN-18, SLN-18T	1587 / 721
Scarifying teeth kit SLN-20, SLN-20T	1623 / 738
Scarifying teeth kit SLN-24, SLN-24T	1948 / 884
Stabilizer Skid Shoes	600 / 273
YOU CAN CHOOSE BETWEEN AGRICULTURAL OR USED	
INDUSTRIAL TIRES	
Agricultural tires (16.5 X 16.1 TL)	
(Used) industrial tires (425/65R22.5)	

PTG SERIES

standard or rear steer



The PTG pull type grader is a versatile machine that can be used for many different tasks.

The PTG RS model adds a Rear Steer System for even more versatility, allowing the grader to clean along terrain edges without getting too close with the tractor.

The blade can move along three axis, swivelling 45 degrees, and can also be raised, lowered, or inclined laterally in order to obtain the ideal angle. Two cylinders insure even working force on both sides of the blade.

Equipment Specifications:

Tires: 21.5L x 16.1 agricultural tires

Hitch: Pintle swivel hitch

Cutting edges: Round type, hardened steel 6" x 5/8"

Spindle: 8000 lb capacity

Hydraulic Circuits Requirement: 4

Blade Vertical Tilt: 15 degrees on each side

Blade Horizontal Tilt: 45 degrees on each side

Clearance Height: 20"

Security Light Kit: Included

Security Chain Kit: Included

Transport Mode Overall Width: 11 3/4'

Transport Mode Overall Length: 21'

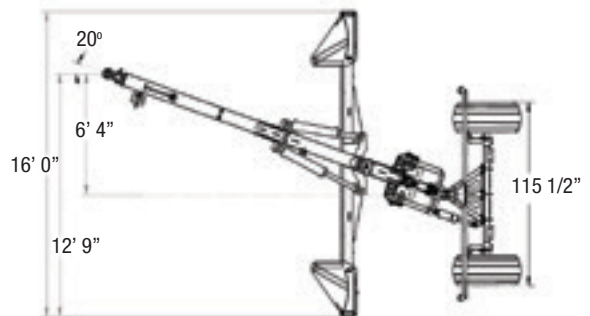
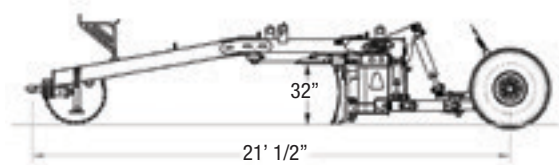

PTG Series

MODEL	WORKING WIDTH ft / m	WEIGHT lb / kg	RECOM. HP HP / KW
PTG-12	12 / 3.66	4980 / 2259	up to 300 / 224
PTG-12 RS	12 / 3.66	5180 / 2350	up to 300 / 224
PTG-14	14 / 4.27	5140 / 2332	up to 300 / 224
PTG-14 RS	14 / 4.27	5340 / 2422	up to 300 / 224
PTG-16	16 / 4.88	6000 / 2722	up to 300 / 224
PTG-16 RS	16 / 4.88	6200 / 2812	up to 300 / 224

OPTIONS

Counterweight Plates Kit (250 lb per kit)

Up to 4 counterweight kits can be installed directly on the blade

SDB SERIES



Perfect for moving bulk materials, our 12 foot SDB silage blade comes with 0° to 25° all-angle capabilities and 10° tilt. It also has a practical height of 51 inches with its standard top extension, and industrial strength RT-400 steel skid shoes and cutting edges.

Compatible with front 3-Point tractors.

Equipment Specifications:

Blade Height: 36"

Blade Height with top extensions: 51"

Hydraulic Angle V45: 25°

Angle Cylinders: 4" x 13"

Hydraulic Vertical Tilt: 10°

Tilt Cylinders: 3" x 6"

Round Cutting Edge: 5/8" x 6"

Skid Shoes (abrasion resistant): Standard

Tilt Cylinders: 3" x 6"

Mouldboard (ripple formed blade): 5/16"

3 Point Hitch: Category 3

PTG Series			
MODEL	WORKING WIDTH ft / m	WEIGHT lb / kg	RECOM. HP HP / KW
SDB-1200	12 / 3.66	3200 / 1452	125-325 / 93- 242
OPTIONS			
1' Side Extension (2x converts to 14' working width)			
High Volume Side Panels			
Serrated Cutting Edges			



TS SERIES

All our tree shears are designed to adapt to most tractors, loaders, telehandlers and skid steer loaders. They operate on standard or high flow hydraulics using one set of remote couplers only, a solenoid valve assembly controls the various applications. Because of their ability to rotate up to 110 degrees, our tree shears are ideal for adjusting to all cutting angles or simply to crimp a cut limb to move it away. The blades are made of the highest capacity steel (RT-400) for longer service life and reduced maintenance. Not only are they solid but the rigid blades will cut through wood without flexing with the grain.

Features:

- 1. 2 function valve.
- 2. Mounting plate (SSL or universal).
- 3. Rotation cylinder.
- 4. Rigid blade guides.
- 5. RT-400 blade.
- 6. Teflon plate.
- 7. Retaining hook.

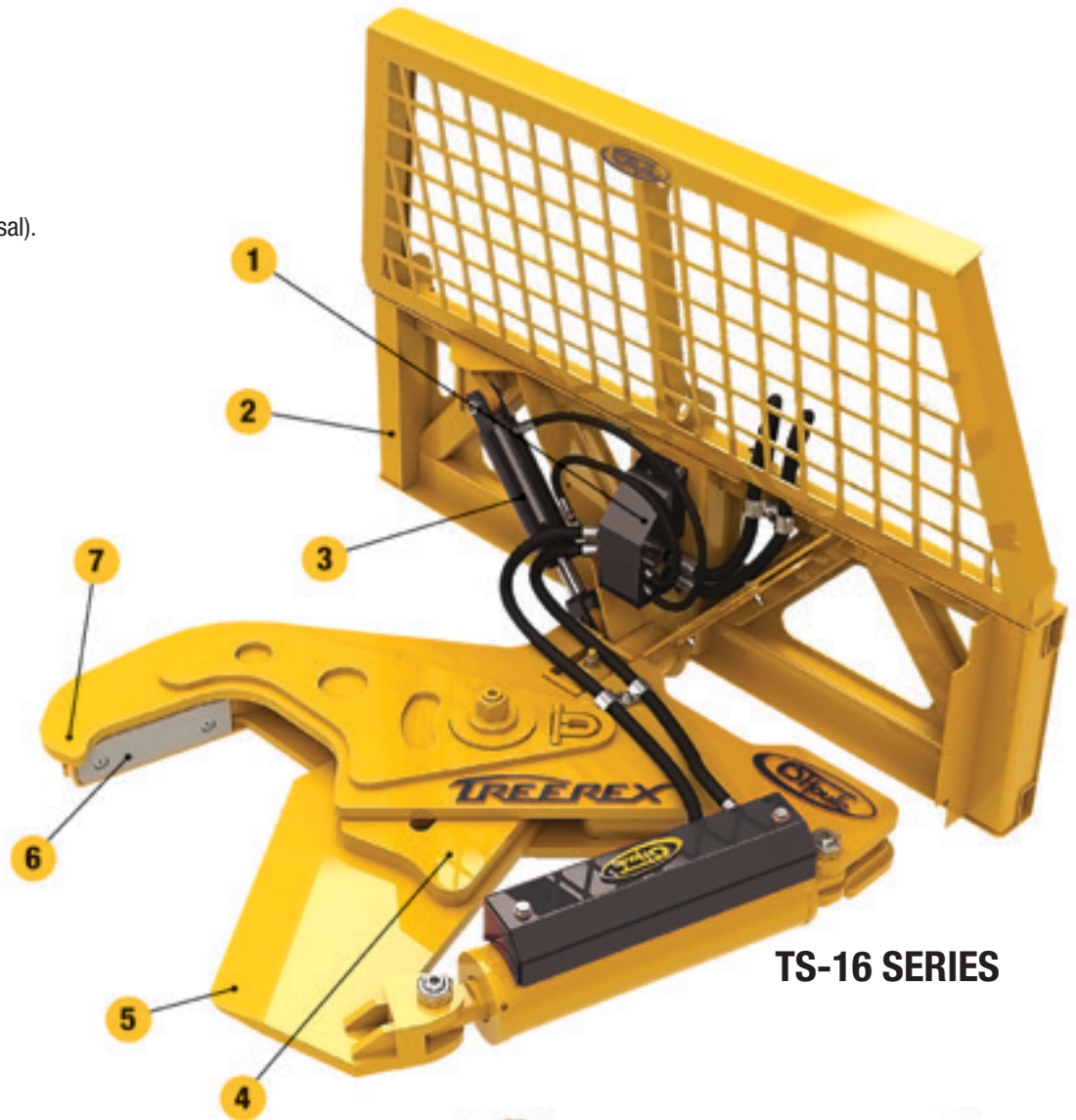

TS-16 SERIES



TS-08 SERIES



TS-10+ SERIES



TS-16+ SERIES



TS-17 SERIES

TS-08 MODEL



Thanks to its narrow shape, the TS-08 is easy to handle and excels in reaching branches and trees in confined spaces.

The TS-08 hydraulic tree shear is designed to trim and cut trees growing in tight spaces and near fences. Its slim design lets you cut trees and branches up to 8" (20 cm) in diameter almost anywhere. It can also be used with small farm tractors, skid steer loaders and telehandlers to give you even more versatility.

Length: 67" (170 cm)

Width: 21" (53 cm)

Tree Cutting Power:

85,000 lb @ 3000 PSI / 38,000 kg @ 206 bars

Rotation: 0 to 100°

Blade: RT-400 Steel

Valve: Solenoid 2 functions 1 command

Hydraulic Outlet: 1

Minimum Oil Flow:

15 GPM @ 2750 PSI / 70 l/m @ 190 bars



TS-08 Model

MODEL	DESCRIPTION	WEIGHT lb / kg
TS-08	Tree shear 8" (20 cm) Univers. att.	1050 / 476
TS-08-SS	Tree shear 8" (20 cm) Skid steer	1124 / 510

OPTIONS

Cat Plug

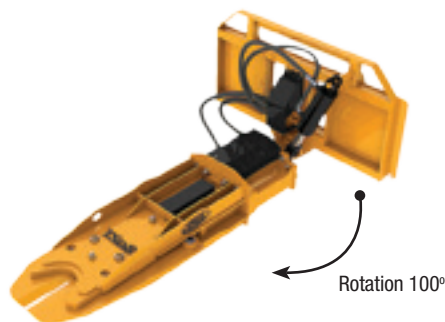

TS-10+ MODEL

for 9500 lb to 15 000 lb excavators



The TS-10+ model hydraulic tree shear is ideal for cutting branches or small trees up to 10" (25 cm) in diameter. Its grapple helps to gain access and handle trees in tight spots. Designed to adapt on mini-excavators or skid steer loaders.

Length: 36" (92 cm)

Width: 31" (80 cm)

Tree Cutting Power:

85,000 lb @ 3000 PSI / 38,000 kg @ 206 bars

Rotation: 0-90° on Universal / No rotation on Skid Steer model

Blade: RT-400 steel

Valve : Solenoid 2 functions 1 command

Hydraulic Outlet: 1

Minimum Oil Flow:

15-20 GPM @ 3000 PSI / 70-90 l/m @ 206 bars



TS-10+ Model

MODEL	DESCRIPTION	WEIGHT lb / kg	
TS-10+	Tree shear 10" (25 cm) Universal attachment	900 / 408	
TS-10+ SS	Tree shear 10" (25 cm) Skid Steer attachment	900 / 408	

TS-16 MODEL (TREEREX)



Cuts through grain without bending.

The particular geometry of the Treerex is shaped like a jaw with a lip that acts as a retaining hook, keeping the tree or branch from moving away when cutting or transporting. The Teflon plate allows for a perfect cut, eliminating the scuffing that occurs on most common models.

It is the most powerful tree shear on the market; it is capable of cutting branches or trees up to 16" (41 cm) in diameter. Its single blade action allows for better control and quality of cut and its ability to rotate allows you to easily cut at angles or move fallen trees. Its low profile allows to cut trees at ground level. It is especially designed for skid steer loaders and telehandlers.

Length: 60" (150 cm)

Width: 58" (147 cm)

Tree Cutting Power:

85,000 lb @ 3000 PSI / 38,000 kg @ 206 bars

Rotation: 0-110°

Blade: RT-400 steel

Valve: Solenoid 2 functions 1 command

Hydraulic Outlet: 1

Minimum Oil Flow:

20-25 GPM @ 2750 PSI / 90-114 l/m @ 190 bars



TS-16 Model (Treerex)

MODEL	DESCRIPTION	WEIGHT lb / kg
TS16	Tree shear 16" (41 cm) Univers. att.	1550 / 703
TS16-SS	Tree shear 16" (41 cm) Skid steer	1550 / 703

OPTIONS

TS-16 Guard	155 / 70
TS-16-SS Guard	165 / 75
Cat Plug	
High flow solenoid	

Rotation 100°



TS-16+ MODEL



The TS-16+ model hydraulic shear is ideal for cutting trees up to 16" (41 cm) in diameter. Its two gripping arms make it possible to hold onto and maneuver the trees as desired. Its sturdy construction allows it to handle the most grueling chores. This shear is designed to adapt on excavators.

Length: 66" (167 cm)

Width: 61" (155 cm)

Tree Cutting Power:

132,500 lbs. @ 3000 psi / 60,100 kg @ 206 bars

Rotation: -20° to +20°

Blade: RT-400 steel

Minimum Oil Flow:

30 GPM @ 3000 PSI / 113,5 l/min @ 206 bars

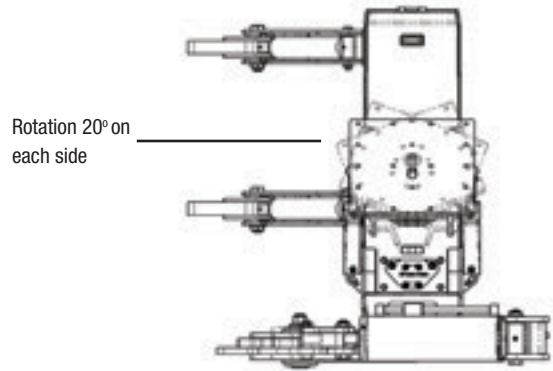

TS-16+ Model

MODEL	DESCRIPTION	WEIGHT lb / kg	
TS16+	Tree shear 16" (41 cm) Univers. att.	3290 / 1492	

TS-17 MODEL



The powerful TS-17 tree shear is Fabrication SHoule's rugged double bladed model. With this tree shear you can easily cut trees up to 17 inches in diameter, at ground level if needed. The replaceable and adjustable steel blades pivot on MOS-2 polyethylene bushings and all pivot points are greaseable. A shield provides increased protection for the hydraulic hoses. Designed for skid steer loaders and telehandlers.

Length: 79" (201 cm).

Width: 44" (112 cm).

Tree Cutting Power:

85,000 lb @ 3000 PSI / 38,636 kg @ 206 bars.

Rotation: None (flat to ground)

Blade: RT-400 steel.

Minimum Oil Flow:

12 GPM (45,5 l/min) @ 2200 PSI (151 bars),

35 GPM (132 l/min) @ 5000 PSI (344 bars).



TS-17 Model

MODEL	DESCRIPTION	WEIGHT lb / kg	
TS-17	Tree shear 17" (67 cm) double blade system	1 675 / 760	





NOTHING COMPARES

Fabrication SHoule is an agricultural and commercial machinery manufacturer. We are the manufacturer of the original rock fork.

We manufacture some of the most robust products on the market, such as grapples, rock rakes, land levelers and snow removal equipment as well as many quick attaches for all types of tractors and compact loaders.

Fabrication SHoule, **Built to Last!**

1 YEAR
WARRANTY
PARTS AND LABOR



300 boul. Industriel
Saint-Germain-de-Grantham, QC J0C 1K0
Tel.: 819 395-4380
Fax: 819 395-5516
info@shoule.com

1 888 404-4380
www.shoule.com