

SCHULTE XH1500/XH1000 Series 4 ROTARY CUTTER

Features and Product Specification

Introduction

The Schulte XH1500/XH1000 Series 4 Rotary Cutters are the latest version of Schulte's popular XH1500/XH1000 heavy duty series rotary cutter line. They retain all of the best features of the original XH1500/XH1000 Rotary Cutters, such as tandem walking axles, heavy duty drive line and deck protection rings, while adding many new features. Below is a listing of key features.

- 1) Drive Line A four gearbox drive line arrangement with a forward mounted power divider allows the use of individual slip clutches to protect the cutter assemblies. The four gearbox drive line allows the wings to operate at angles from 25° down up to transport position.
- 2) CV Power Shaft A low maintenance constant velocity(CV) power shaft allows tractor turns of up to 80° with no drive line vibration. Ample clearance is provided around the forward hitch to allow for tight turns. Few competitive machines can match the turning ability of this cutter.
- 3) Equal Angle Hitch (Schulte Exclusive) An optional Equal Angle hitch is available on 540 RPM drive units. This Schulte exclusive eliminates the need for a CV shaft while still allowing for turns up to and exceeding 80 degrees. This system uses a standard u-joint shaft and is lighter to hook up to the tractor than the CV type.
- 4) Floating Hitch (Industry First)The hitch lifting rods use a sliding sleeve that allows the cutter's front skids to pass over an obstruction without tending to lever up the back of the cutter or bend the hitch lifting rods.
- 5) Floating Wings (Industry First)The wing lift mechanism uses a floating link that allows the wings to move from 25° down to 35° up without pumping the wing lifting cylinders. This arrangement reduces wear on the cylinders and reduces possible stress on the frames when travelling over uneven ground.
- 6) Deck Rings (Industry First) 3/8" thick formed deck rings are welded to the underside of the decks. These rings prevent the blades from contacting the deck should a blade become bent. Deck rings have been standard on the Schulte XH models since 1992.

- 7) Walking Axle (Industry First) A set of walking axles control cutting height at the rear of the machine. The walking axles are positioned as far forward as possible to best control cutter height over uneven terrain. Available with optional wing walking axles.
- 8) Pivot Points (Industry First) Major frame pivots are protected by replaceable spring steel bushings. All pivot points are greasable and include a locking pin head to prevent wear at frame attachment points. All pin shafts are made of high carbon steel. This type of pivot detailing is not available on other major brands of rotary cutters and ensures that precision in the lifting mechanism can be maintained over the life of the machine.
- 9) Domed Deck Single domed sweep clean decks eliminate build-up of debris and prevents rusting on the top side.
- 10) Welding Top side of deck is continuously welded to increase structural strength and minimize rusting.
- 11) Stump Jumpers (Industry First) ¼" thick round skid pans (stump jumpers) are standard equipment. Schulte skid pans are spun formed rather than press formed as is common on competitive designs. The spin forming process ensures a well balanced pan. An exclusive replaceable pentagon blade bolt bushing is used where the blade bolt attaches to the pan. This sleeve is made of a high carbon steel and is less prone to damage or wear than if the blade bolt mounting hole was placed directly into the pan's cross bar, as is the case on competitive designs. The pan is driven by a 3" (75mm) tapered and splined shaft on the gearbox.

- 12) Swivel Hitch A swivel hitch allows the cutter to move over rough terrain without the hitch clevis binding up onto the tractor drawbar. The swivel assembly uses a strong 2" main shaft. Should the assembly loosen up over time machine bushings can be added to maintain a snug fit. A spring steel bushing protects the hitch frame from wear.
- 13) Blades/Options Various blade options are available from Schulte. Such as: Schulte Super Suction, Standard suction, brush blades and shredder blades. Whatever your application Schulte has your blade.
- 14) Shielding Comprehensive drive line shielding allows the use of short bells on power shafts resulting in better access to grease zerks. The shielding can be easily unclipped for access to gearboxes, slip clutches and universal joints. A self-locking latch and support straps apply force under the main shield to prevent it from rattling.
- 15) Levelling (Industry First) Outer wing wheels include an adjustment screw so that the can be placed out of level up or down 3". This allows cut height to be fine-tuned across the machine for precision cutting along roadsides.
- 16) Hoses Hoses can be organized along the right or left side of the center frame so that shielding covers can more easily be tilted back for service access.
- 17) Rear Beam The center section wheel standard uses a large 6" O.D. x 5.5" I.D tube. The lifting system is symmetrical resulting in an even loading on both sides of the center frame. Spring steel bushings and high carbon steel pins are used at all pivot points.
- 18) Power Shafts Power shafts are low maintenance have shorter bells for better access to grease zerks. All power shafts have tapered pin type connections instead of split clamp.
- 19) Phased Hydraulics Phased hydraulic cylinders are standard to provide level lifting across the width of the cutter. Centre and wing sections all raise and lower together.

- 20) Gearbox Mounts Heavy duty gearbox mounting pads are able to handle the roughest working conditions. Gearbox bolts can be retightened from the top side.
- 21) Centre Deck The hinge line is directly over the center of the blade overlap providing the best arrangement of blade overlap at all wing angles. Track width has been increased to provide maximum transport stability.
- 22) Wing Skids Replaceable High Tensile Outer wing skids are two pieces. The forward section is extra wide to prevent gouging and can be mounted outside or inside the side skirt depending on requirements.
- 23) Centre Skids Replaceable High Tensile Skid shoes are a two piece design. The shoes can be removed entirely when cutting over level ground.
- 24) Wing Lift Wing lifting lug runs through the deck and is then capped on the underside to totally eliminate any chance of coming loose even if the wing is suspended off the ground during operation.
- 25) Narrow Transport Mechanism The NTM (Narrow Transport Mechanism) is incorporate into the center hydraulic lock up system. The wing wheels can be tucked inside of the width of the wings when in transport mode allowing for a stable, safe and ultra- narrow transport width of 88".
- 26) Gearboxes Heavy Duty
1 3/4" Input Shafts.
3" (75mm) Tapered and Splined Down Shafts.
Six year limited gearbox warranty.

Drive Line Specification

1) Power Divider

260 HP - Bondioli & Pavesi 8191

Gear Ratios	540 RPM	1:1.35	729 RPM wing shaft speed
	1000 RPM	1.35:1	741 RPM wing shaft speed

2) Right-Angle Drives

225 HP - Bondioli & Pavesi 3125 - Horsepower rating varies depending on input speed, gearbox ratio, and whether usage is continuous or intermittent.

Gear Ratios	540 RPM	1:1.35 wing	986 RPM at blades
		1:1.57 center	848 RPM at blades
	1000 RPM	1:1.35 wing	1002 RPM at blades
		1.18:1 center	850 RPM at blades

3) Tractor Power Shaft

540 RPM ASAE Category 6, Bondioli & Pavesi Size H8 SFT, 80° wide angle, low maintenance, constant velocity joint with four lobe SFT sliding members and a tapered pin type yoke connection to cutter.

1000 RPM ASAE Category 5, Bondioli & Pavesi Size 6 SFT, 80° wide angle, low maintenance, constant velocity joint with four lobe SFT sliding members and a tapered pin type yoke connection to cutter.

4) Wing & Centre Power Shafts

ASAE Category 5, Bondioli & Pavesi Size 8 Global Series, with two plate slip clutch. All slip clutches are set to 12,834 in lbs (1,450 Nm). Tapered pin type yokes are used to connect power shafts to gearboxes. Wing shafts are Heat treated to reduce friction during operation and increase service life.

5) Cutter Assemblies

Blades - 1/2" x 4" or 1/2" x 5"

Material: SAE 5160, chromium steel heat treated to RC 38-42

Form: Updraft, single finished edge

Blade Bolts - Thread size: 1-1/8-12

Material: SAE 4140, chromium molybdenum steel, tempered to RC33-39

Form: Pentagon shaped blade bolt lock along with pentagon shaped blade bolt pan bar bushing, enlarged forged head for blade retention.

Lock nuts: Nylon insert type, reusable maximum 5 times.

Circular Skid Pans - Spin formed 1/4" material, 1" A36 backing bars, hole centers precision machined. ASA 6/12" Z16 tapered spline mounting hub, with castellated nut and cotter pin.

6) Frames

Deck - Material: 7 gauge, ASTM A-569 hot rolled carbon-manganese steel.

Bracing - Material: ASTM A-569 7 gauge hot rolled carbon-manganese steel, ASTM A-36 structural steel, 3/16", ASTM A-500 hollow structural tubing.

Extensive formed bracing and structural tubing is used to reinforce the cutter deck.

Skids - Skids are located at the forward end of the center section and at the outer wing edges. Material: ASTM A514 alloy steel on center sections skids and front edge of wing skids, and C1045 flat on back of wing sections skids.

Wheel Standards - Centre section main tube 6" O.D. x 5.5" I.D (1/4" wall). ASTM A-500, wheel arms 4 x 4 x .250 ASTM A-500 on center, 4 x 3 x .250 ASTM A-500 on wings.

7) Running Gear

Hubs and Axles - 5 bolt, 5.50" bolt circle, 4" pilot, 1.625 diameter axle.

Capacity: 2760 lbs. @ 20 MPH. Wheel bolts: .500-20 UNF x 1.250

Tires and Wheels

- Segmented Tire and Flat Base Demountable Wheel, 9" diameter.

Wheel size: 5 bolt, 5.50" bolt circle, 4" pilot, 9" rim diameter, 5-17/32" diameter hub holes, steel gauge 9. Tire size: 6.00 x 9, 21.0" O.D.

- Aircraft Tire and Flat Base Demountable Wheel, 10" diameter.

Wheel size: 5 bolt, 5.50" bolt circle, 4" pilot, 10" rim diameter, 5-17/32" diameter hub holes,

8) Hydraulics

Hydraulic Lift Cylinder - 3.5 x 8 welded cylinder, 3.5 diameter bore, 8" stroke, 1.25 diameter rod, 18-1/8 CPC, with mechanical depth stop collar. Minimum system pressure required to operate, 1750 psi.

Hydraulic Wing Lift Cylinders - 3 x 14 welded cylinder, 3.0 diameter bore, 14" stroke, 1.25 diameter rod, 22-1/4 CPC. Minimum system pressure required to operate, 1000 psi.

Hydraulic Phasing System - 3 x 8, 3-1/4 x 8 and 3-1/2 x 8 welded cylinders, 3.0", 3.25", and 3.5" diameter bores, 1-1/4 diameter rods, 18-1/8 CPC. Rephasing orifices and mechanical depth stop collars fitted to all cylinders. Minimum system pressure required to operate: 1750 psi.

All cylinders are equipped with Lion 1000 chrome rods. steel gauge 9. Tire size: 6.6 x 10, 24" O.D.

General Data	XH1500	XH1000
Cutting width	180" (4.57 m)	126" (3.20 m)
Overall width	190" (4.83 m)	139" (3.53 m)
Overall length	192" (4.88 m)	192" (4.88 m)
Transport width	88" (2.24 m)	88" (2.24 m)
Transport height	88" (2.24 m)	88" (2.24 m)
Approximate weight range	5800 lbs (2636 kg)	
Dependent on options	6100 lbs (2750 kg)	5200 lbs (2364 kg)
Approximate transport hitch weight	1900 lbs (864 kg)	1800 lbs (800 kg)
Minimum Tractor HP	65 HP (52 kw)	50 HP (45 kw)
Recommended tractor HP	85 HP (67 kw)	75 HP (60 kw)
Cutting height	1.5 to 17.5" (38 to 444mm)	1.5 to 17.5" (38 to 444mm)
Ground clearance, transport	16" (406 mm)	16" (406 mm)
Cutting capacity	4" (102mm) material	4" (102mm) material
Tractor hydraulics, minimum	3 single acting circuits @ 1750 psi	3 single acting circuits @ 1750 psi
Tractor hydraulics, phasing	1 double acting circuit @ 1750 psi 2 single acting circuits @ 1750 psi	1 double acting circuit @ 1750 psi 2 single acting circuits @ 1750 psi
Blade tip speed	540 rpm	540 rpm
Center	848 rpm (15,991 ft/min) (4871m/min)	848 rpm (15,981 ft/min) (4871m/min)
Wing	986 rpm (15,493 ft/min) (4722m/min)	986 rpm (15,493 ft/min) (4722m/min)
Blade tip speed	1000 rpm	1000 rpm
Center	850 rpm (16,022 ft/min) (4884m/min)	850 rpm (16,022 ft/min) (487m/min)
Wing	1002 rpm (15,743 ft/min) (4798m/min)	1002 rpm (15,743 ft/min) (4798m/min)
Working range of wings	25° down to 90° up	25° down to 90° up
Blade overlap	6.5" (165mm)	6.5" (165mm)

Optional Equipment

- *Shredder blade kit*
- *Safety light kit*
- *Double acting wing lift kit*
- *Winch type wing lift kit*
- *Towing hitch kit*
- *Spool-valve*
- *and other various kits*

Wing Gauge Wheels

New kits for 2005 on the XH1500/XH1000 Schulte rotary cutters.

New Heavier Stump Jumpers:
3/4" thick stump jumper skin that is machine spun and pressed for balance.
1" thick flat design pan bar increases weld area to the skin. 3/8" thick cross members increase structural strength.

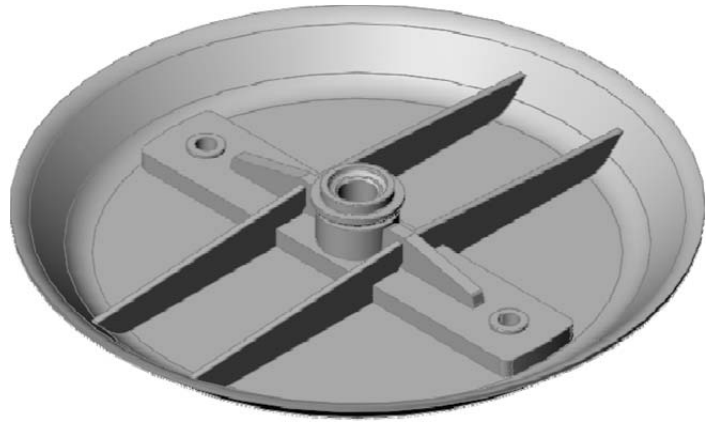

Heavier 517 hubs and axles with Bolt in axles keep down time to a minimum. Built in metal seal guard protects hub seals from damage

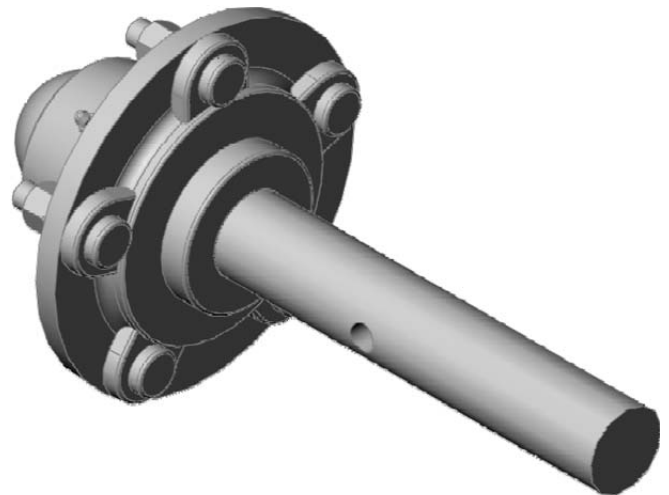

Pentagon Blade and Blade bolt bushing adds strength to the holding area of the blade bolt and ensures the bolt cannot turn. The pentagon shaped bushing is replaceable and is welded into the pan cross bar.

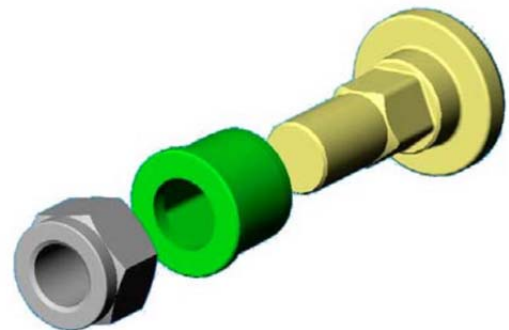

20090609