

Technical sheet :

M 70-2 H



| Technical characteristics | | Metric | |
|---------------------------|---|------------------|--------------------------|
| 1.1 | Manufacturer | | Manitou |
| 1.2 | Model Name | | M 70-2 H |
| 1.3 | Power source | | Diesel |
| 1.4 | Operator type | | Sitting |
| 1.5 | Max. capacity | Q | 7000 kg |
| 1.6 | Load centre of gravity | c | 600 mm |
| 1.8 | Load distance, centre of drive axle to fork | x | 803 mm |
| 1.9 | Wheelbase | y | 2493 mm |
| Weight | | | |
| 2.1 | Service weight | | 9880 kg |
| 2.2 | Weight on front axle (laden) / rear axle (laden) | | 14954 kg / 1926 kg |
| 2.3 | Weight on front axle (Unladen) / rear axle (Unladen) | | 4040 kg / 5840 kg |
| Wheels | | | |
| 3.1 | Tyres type | | Pneumatic |
| 3.2 | Dimensions of front wheels | | 18R19,5 8T N 20XF |
| 3.3 | Dimensions of rear wheels | | 265/70R19,5 6T P30 HT3 |
| 3.5 | Number of front wheels / rear wheels | | 2 / 2 |
| 3.5.2 | Number of drive wheels | | 2 |
| 3.6 | Front wheel gauge | b10 | 1700 mm |
| 3.7 | Rear wheel gauge | b11 | 1545 mm |
| Dimensions | | | |
| 4.1 | Tilt of Mast Forward (deg) / Backward (deg) | α / β | 15 / 15 |
| 4.7 | Height of overhead guard (cabin) | h6 | 2475 mm |
| 4.8 | Seat height/stand height | h7 | 1485 mm |
| 4.19 | Overall length | l1 | 5700 mm |
| 4.20 | Length to face of forks | l2 | 4206 mm |
| 4.21 | Overall width | b1 | 2155 mm |
| 4.22 | Forks section x width x length | s / e / l | 70 mm x 150 mm / 1500 mm |
| 4.23 | Fork carriage ISO 2328 (class/form) A/B | | FEM4 |
| 4.24 | Fork carriage width | b3 | 1750 mm |
| 4.31 | Ground clearance below mast | m1 | 300 mm |
| 4.32 | Ground clearance at centre of wheelbase | m2 | 410 mm |
| 4.34 | Aisle width for 800 x 1200 pallet lengthways | Ast | 6703 mm |
| 4.35 | Turning radius | Wa | 4200 mm |
| Performances | | | |
| 5.1 | Travel speed (laden / unladen) | | 11 km/h / 23 km/h |
| 5.2 | Lifting speed (laden / unladen) | | 0.32 m/s / 0.32 m/s |
| 5.3 | Lowering speed (laden / unladen) | | 0.40 m/s / 0.34 m/s |
| 5.5 | Drawbar pull (Laden / Unladen) | | 8060 daN / 2930 daN |
| 5.7 | Gradeability (laden / unladen) | | 45 % / 27 % |
| 5.10 | Service brake | | Hydraulic |
| Engine | | | |
| 7.1 | Engine brand / model | | Deutz / TD 3.6 |
| 7.2 | Engine power according to ISO 1585 | | 55.40 kW |
| 7.3 | Rated speed | | 2500 rpm |
| 7.4 | Number of cylinders | | 4 |
| Miscellaneous | | | |
| 8.2 | Working hydraulic pressure for attachments | | 230 bar |
| 8.3 | Oil flow rate for attachments | | 79.99 l/min |
| 8.4 | Sound level at the driver's ear according to DIN 12 053 | | 78 dB |

M 70-2 H - Dimensional drawing

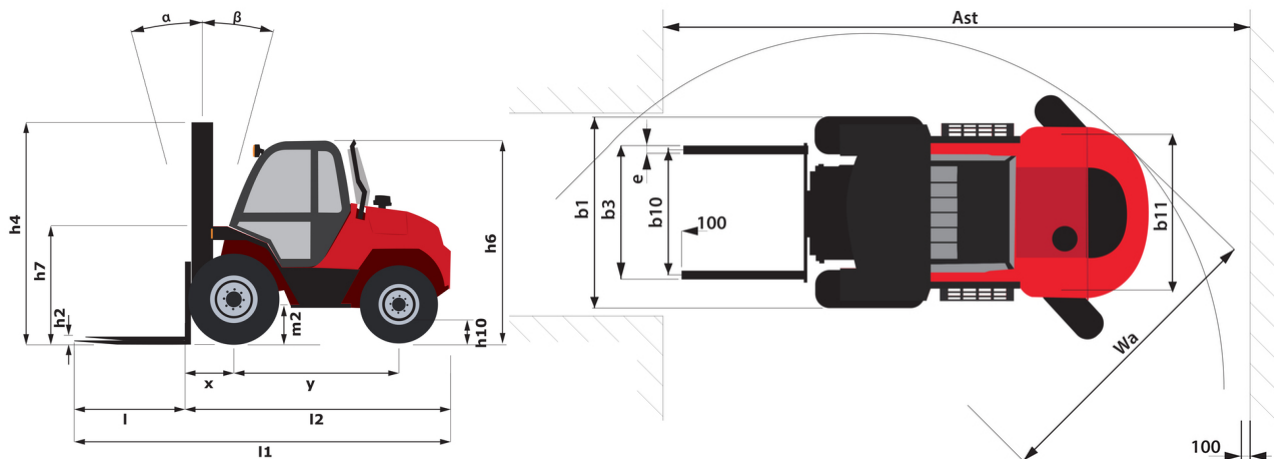

Characteristics of masts and residual capacities

| Duplex with total visibility | | FVD 36 | FVD 40 | FVD 45 |
|---|----|---------|---------|---------|
| h2 - Free lift | mm | 0 | 0 | 0 |
| h1 - Height mast lowered * | mm | 3160 | 3360 | 3610 |
| h4 - Height mast extended * | mm | 4965 | 5370 | 5865 |
| h3 - Max. lifting height | mm | 4500 | 4500 | 4500 |
| α / β - Mast inclination (front / rear) | ° | 15 / 15 | 15 / 15 | 15 / 15 |
| Residual capacity at max height | kg | 7000 | 7000 | 7000 |
| Residual capacity without attachment (Industrial load chart) | kg | 7000 | 7000 | 7000 |



Head Office

B.P. 249 - 430 rue de l'Aubinière

44150 Ancenis Cedex - France

Tel: +33 (0)2 40 09 10 11 - Fax: +33 (0)2 40 09 10 97

www.manitou.com



This publication provides a description of the configuration versions and options for Manitou products, which may differ for equipment. The equipment presented in this brochure may be part of a series, as an option, or it may not be available, depending on the versions. Manitou reserves the right, at any time and without notice, to amend the specifications described and represented. The specifications provided do not bind the manufacturer. For more details, please contact your Manitou agent. This is not a contractually binding document. The presentation of the products is not contractually binding. List of specifications non-exhaustive. The logos as well as the visual identity of the company are owned by Manitou and cannot be used without authorisation. All rights reserved. The photos and diagrams contained in this brochure are only provided for consultation and information purposes.

MANITOU BF SA - Limited company with board of directors - Share capital: 39,668,399 euros - 857 802 508 RCS Nantes