

Technical sheet :

M 40-4



Technical characteristics		Metric	
1.1	Manufacturer		Manitou
1.2	Model Name		M 40-4
1.3	Power source		Diesel
1.4	Operator type		Sitting
1.5	Max. capacity	Q	4000 kg
1.6	Load centre of gravity	c	500 mm
1.8	Load distance, centre of drive axle to fork	x	763 mm
1.9	Wheelbase	y	2120 mm
Weight			
2.1	Service weight		6965 kg
2.2	Weight on front axle (laden) / rear axle (laden)		9010 kg / 1955 kg
2.3	Weight on front axle (Unladen) / rear axle (Unladen)		2625 kg / 4340 kg
Wheels			
3.1	Tyres type		Pneumatic
3.2	Dimensions of front wheels		18-22.5 MPT06
3.3	Dimensions of rear wheels		340/80 R18 XMCL
3.5	Number of front wheels / rear wheels		2 / 2
3.5.2	Number of drive wheels		4
3.6	Front wheel gauge	b10	1620 mm
3.7	Rear wheel gauge	b11	1740 mm
Dimensions			
4.1	Tilt of Mast Forward (deg) / Backward (deg)	α / β	15 / 15
4.7	Height of overhead guard (cabin)	h6	2500 mm
4.8	Seat height/stand height	h7	1480 mm
4.19	Overall length	l1	4858 mm
4.20	Length to face of forks	l2	3658 mm
4.21	Overall width	b1	2080 mm
4.22	Forks section x width x length	s / e / l	50 mm x 150 mm / 1200 mm
4.23	Fork carriage ISO 2328 (class/form) A/B		FEM 3A
4.24	Fork carriage width	b3	1670 mm
4.31	Ground clearance below mast	m1	295 mm
4.32	Ground clearance at centre of wheelbase	m2	380 mm
4.34	Aisle width for 800 x 1200 pallet lengthways	Ast	6732 mm
4.35	Turning radius	Wa	4570 mm
Performances			
5.1	Travel speed (laden / unladen)		10 km/h / 24 km/h
5.2	Lifting speed (laden / unladen)		0.40 m/s / 0.40 m/s
5.3	Lowering speed (laden / unladen)		0.40 m/s / 0.30 m/s
5.5	Drawbar pull (Laden)		1020 daN
5.10	Service brake		Hydraulic
Engine			
7.1	Engine brand / model		Perkins / 854F-E34T WF
7.2	Engine power according to ISO 1585		55 kW
7.3	Rated speed		2200 rpm
7.4	Number of cylinders / Capacity of cylinders		4 · 3400 cm ³
Miscellaneous			
8.2	Working hydraulic pressure for attachments		210 bar
8.3	Oil flow rate for attachments		97 l/min
8.4	Sound level at the driver's ear according to DIN 12 053		76 dB

M 40-4 - Dimensional drawing

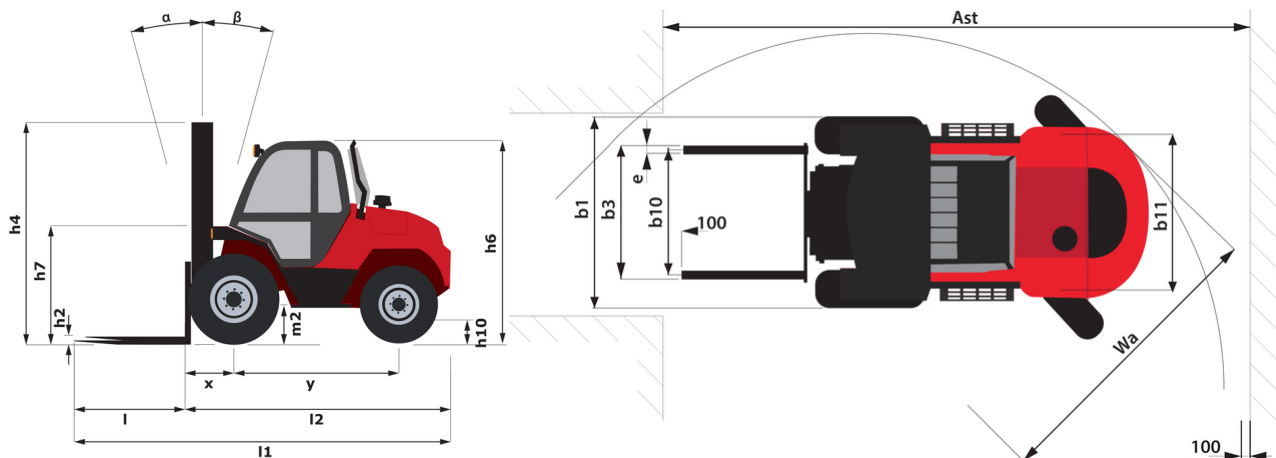

Characteristics of masts and residual capacities

Duplex with total visibility		FVD 30	FVD 33	FVD 35	FVD 37	FVD 40	FVD 45	FVD 50
h2 - Free lift	mm	0	0	0	0	0	0	0
h1 - Height mast lowered *	mm	2425	2575	2675	2775	2925	3175	3425
h4 - Height mast extended *	mm	3977	4277	4477	4677	4977	5477	5977
h3 - Max. lifting height	mm	6000	6000	6000	6000	6000	6000	6000
α / β - Mast inclination (front / rear)	°	15 / 15	15 / 15	15 / 15	15 / 15	15 / 15	15 / 15	15 / 15
Residual capacity at max height	kg	4000	4000	4000	4000	4000	4000	3800
Residual capacity without attachment (Industrial load chart)	kg	4000	4000	4000	4000	4000	4000	3800
Residual capacity with integrated side shift (Industrial load chart)	kg	4000	4000	4000	4000	4000	4000	3400

Free lift triplex		FLT 37	FLT 40	FLT 43	FLT 45	FLT 47	FLT 50	FLT 55	FLT 60
h2 - Free lift	mm	1258	1258	1458	1533	1593	1708	1858	2033
h1 - Height mast lowered *	mm	2175	2275	2375	2450	2510	2625	2775	2950
h4 - Height mast extended *	mm	4677	4967	5267	5467	5667	5967	6467	6967
h3 - Max. lifting height	mm	6000	6000	6000	6000	6000	6000	6000	6000
α / β - Mast inclination (front / rear)	°	15 / 15	15 / 15	15 / 15	15 / 15	15 / 15	15 / 15	15 / 15	15 / 15
Residual capacity at max height	kg	4000	4000	4000	4000	3800	3700	3200	2600
Residual capacity without attachment (Industrial load chart)	kg	4000	4000	4000	4000	3800	3700	3200	2600
Residual capacity with integrated side shift (Industrial load chart)	kg	4000	4000	4000	4000	3400	3300	2900	2350

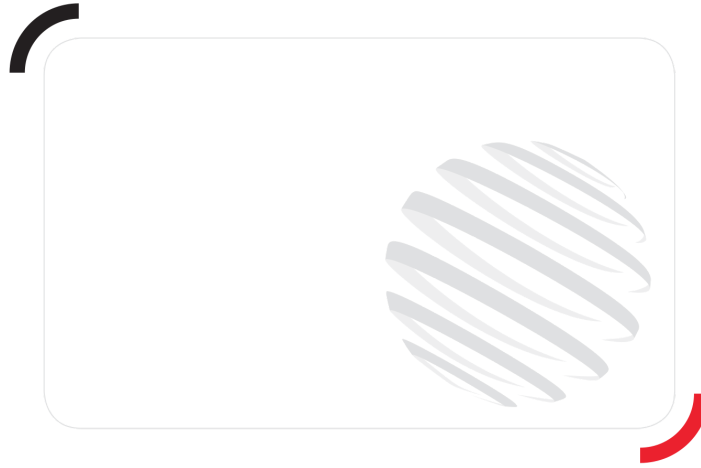

Head Office

B.P. 249 - 430 rue de l'Aubinière

44150 Ancenis Cedex - France

Tel: +33 (0)2 40 09 10 11 - Fax: +33 (0)2 40 09 10 97

www.manitou.com



This publication provides a description of the configuration versions and options for Manitou products, which may differ for equipment. The equipment presented in this brochure may be part of a series, as an option, or it may not be available, depending on the versions. Manitou reserves the right, at any time and without notice, to amend the specifications described and represented. The specifications provided do not bind the manufacturer. For more details, please contact your Manitou agent. This is not a contractually binding document. The presentation of the products is not contractually binding. List of specifications non-exhaustive. The logos as well as the visual identity of the company are owned by Manitou and cannot be used without authorisation. All rights reserved. The photos and diagrams contained in this brochure are only provided for consultation and information purposes.

MANITOU BF SA - Limited company with board of directors - Share capital: 39,668,399 euros - 857 802 508 RCS Nantes