

Technical sheet :

MTA 8044 SERIES IV



Capacities		Metric
Max. capacity		3629 kg
Max. lifting height		13.40 m
Max. outreach		9.30 m
Weight and dimensions		
Overall length to carriage	l11	6.04 m
Overall length (with forks)	l1	6.04 m
Overall width	b1	2.50 m
Overall height	h17	2.34 m
Wheelbase	y	3.03 m
Ground clearance	m4	406 mm
Overall cab width	b4	838 mm
Tilt-up angle	a4	12 °
Tilt-down angle	a5	112 °
External turning radius	Wa3	4.20 m
Unladen weight (with forks)		10660 kg
Overall weight		10660 kg
Standard tyres		13 x 24
Frame levelling longitudinal +/-		10 °
Performances		
Lifting		11 s
Lowering		8 s
Extension		14 s
Retraction		12 s
Crowd		7 s
Dump		4 s
Engine		
Engine brand		Deutz
Engine norm		Tier 4 final
Engine model		TCD 3.6 L4
Number of cylinders / Capacity of cylinders		4 - 3.80 cm³
Power (kW)		89 kW
Max. torque / Engine rotation		480 Nm @ 1600 rpm
Transmission		
Transmission type		Torque converter with powershift
Number of gears (forward / reverse)		3 / 3
Travel speed (laden)		31.50 km/h
Max. travel speed		31.50 km/h
Parking brake		SAHR
Service brake		Wet disc brakes
Axle Manufacturer		Dana
Hydraulics		
Hydraulic pump type		Gear pump
Hydraulic flow / Pressure		157 l/min / 207 bar
Tank capacities		
Engine oil		14.70 l
Hydraulic oil		170 l
Fuel tank		178 l
DEF tank capacity		19 l
Miscellaneous		
Steering wheels (front / rear)		2 / 2
Drive wheels (front / rear)		2 / 2
Safety cab homologation		ROPS/FOPS
Controls		Single joystick with FNR

MTA 8044 Series IV - Dimensional drawing

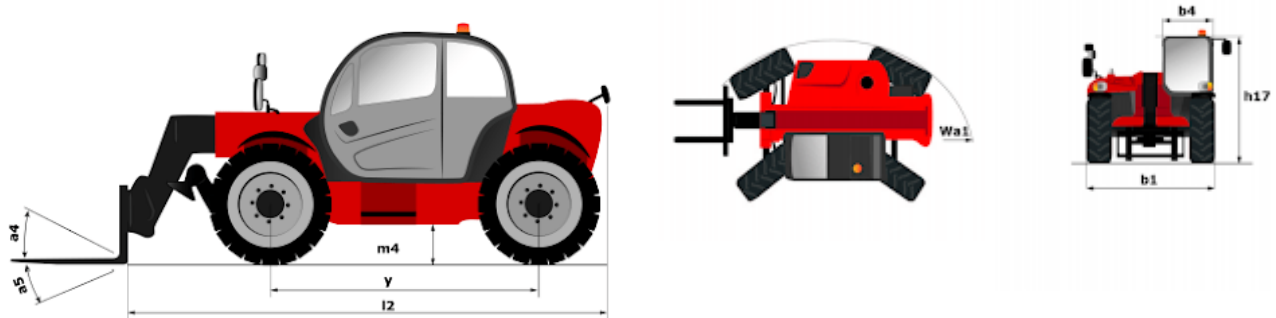

MTA 8044 Series IV - Load chart

Machine on tyres with forks Metric

6,000

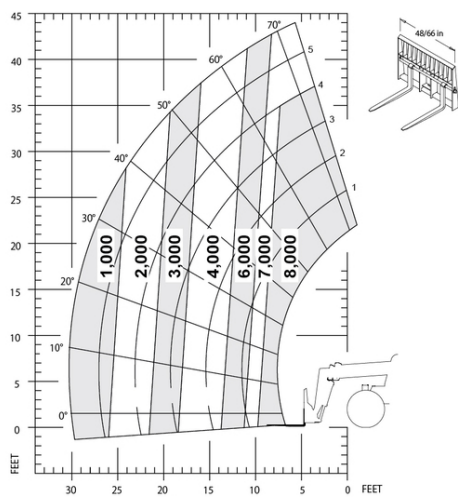

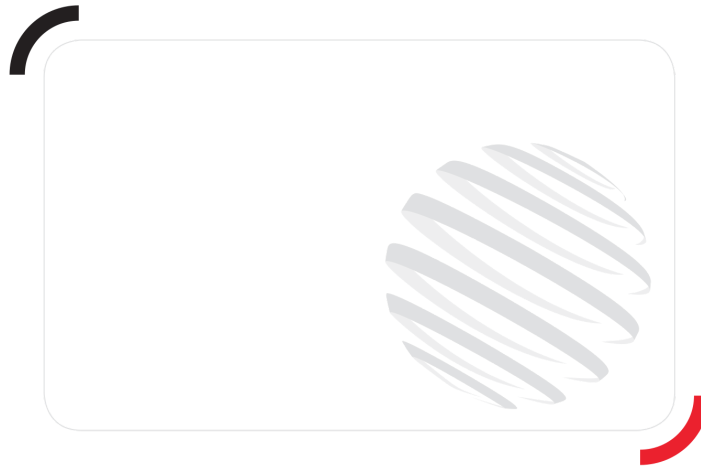

Head Office

B.P. 249 - 430 rue de l'Aubinière

44150 Ancenis Cedex - France

Tel: +33 (0)2 40 09 10 11 - Fax: +33 (0)2 40 09 10 97

www.manitou.com



This publication provides a description of the configuration versions and options for Manitou products, which may differ for equipment. The equipment presented in this brochure may be part of a series, as an option, or it may not be available, depending on the versions. Manitou reserves the right, at any time and without notice, to amend the specifications described and represented. The specifications provided do not bind the manufacturer. For more details, please contact your Manitou agent. This is not a contractually binding document. The presentation of the products is not contractually binding. List of specifications non-exhaustive. The logos as well as the visual identity of the company are owned by Manitou and cannot be used without authorisation. All rights reserved. The photos and diagrams contained in this brochure are only provided for consultation and information purposes.

MANITOU BF SA - Limited company with board of directors - Share capital: 39,668,399 euros - 857 802 508 RCS Nantes