

Technical sheet :

MSI 50



Technical characteristics		Metric	
1.1	Manufacturer		Manitou
1.2	Model Name		MSI 50
1.3	Power source		Diesel
1.4	Operator type		Sitting
1.5	Max. capacity	Q	5000 kg
1.6	Load centre of gravity	c	600 mm
1.8	Load distance, centre of drive axle to fork	x	701 mm
1.9	Wheelbase	y	2075 mm
Weight			
2.1	Service weight		8420 kg
2.2	Weight on front axle (laden) / rear axle (laden)		11467 kg / 1953 kg
2.3	Weight on front axle (Unladen) / rear axle (Unladen)		3489 kg / 4931 kg
Wheels			
3.1	Tyres type		Pneumatic
3.2	Dimensions of front wheels		315/70 R22,5
3.3	Dimensions of rear wheels		225/75 R15
3.5	Number of front wheels / rear wheels		2 / 2
3.5.2	Number of drive wheels		2
3.6	Front wheel gauge	b10	1420 mm
3.7	Rear wheel gauge	b11	1142 mm
Dimensions			
4.1	Tilt of Mast Forward (deg) / Backward (deg)	α / β	10 / 12
4.12	Height of towing bar (coupling height)	h10	540 mm
4.19	Overall length	l1	4584 mm
4.20	Length to face of forks	l2	3384 mm
4.21	Overall width	b1	1732 mm
4.22	Forks section / width / length	s / e / l	60 mm x 150 mm / 1200 mm
4.23	Fork carriage ISO 2328 (class/form) A/B		4A
4.24	Fork carriage width	b3	1670 mm
4.31	Ground clearance below mast	m1	185 mm
4.32	Ground clearance at centre of wheelbase	m2	225 mm
4.33	Aisle Width for pallets 1000 x 1200 crossways	Ast	5041 mm
4.35	Turning radius	Wa	2950 mm
4.36	Internal turning radius (over tyres)	b13	125 mm
4.8	Seat height/stand height	h7	1300 mm
Performances			
5.1	Travel speed (laden / unladen)		22 km/h / 22 km/h
5.2	Lifting speed (laden / unladen)		0.50 m/s / 0.50 m/s
5.3	Lowering speed (laden / unladen)		0.40 m/s / 0.40 m/s
5.5	Drawbar pull (Laden / Unladen)		3350 daN / 2420 daN
5.7	Gradeability (laden / unladen)		24 % / 26 %
5.10	Service brake		Hydraulic
Engine			
7.1	Engine brand / model		Perkins / 854 F 10794
7.2	Engine power according to ISO 1585		55 kW
7.3	Rated speed		2200 rpm
7.4	Number of cylinders / Capacity of cylinders		4 - 3400 cm ³
Miscellaneous			
8.1	Type of drive control		Hydraulic
8.2	Working hydraulic pressure for attachments		230 bar
8.3	Oil flow rate for attachments		45 l/min
8.4	Measured/guaranteed mean noise level at the ear of the operator		< 81 dB

MSI 50 - Dimensional drawing

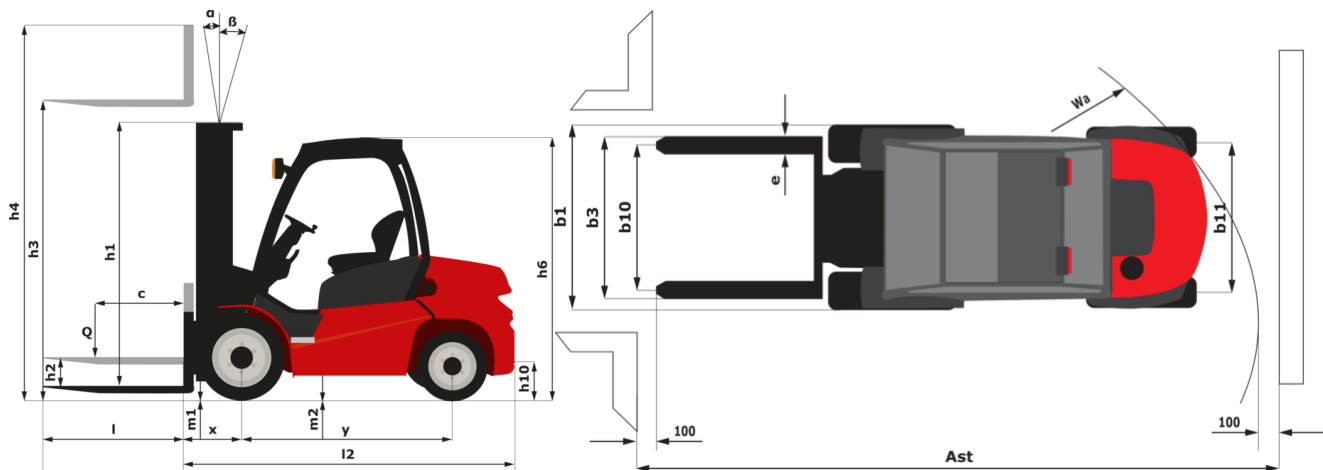

Characteristics of masts and residual capacities

Duplex with total visibility		FVD 30	FVD 33	FVD 35	FVD 37	FVD 40	FVD 45	FVD 50
h1 - Height mast lowered *	mm	2425	2575	2675	2775	2925	3175	3425
h3 - Lifting Height	mm	3000	3300	3500	3500	4000	4500	5000
h4 - Height mast extended *	mm	3972	4272	4472	4672	4972	5472	5972
α / β - Mast inclination (front / rear)	°	10 / 12	10 / 12	10 / 12	10 / 12	10 / 12	10 / 12	10 / 12
Residual capacity at max height	kg	5000	5000	5000	5000	5000	4800	4800

Free lift triplex		FLT 37	FLT 40	FLT 43	FLT 45	FLT 47	FLT 50	FLT 55	FLT 60
h2 - Free lift	mm	1263	1363	1463	1538	1598	1713	1863	2038
h1 - Height mast lowered *	mm	2175	2275	2375	2450	2510	2625	2775	2950
h3 - Lifting Height	mm	3700	4000	4300	4500	4700	5000	5500	6000
h4 - Height mast extended *	mm	4662	4962	5262	5462	5662	5962	6462	6962
α / β - Mast inclination (front / rear)	°	10 / 12	10 / 12	10 / 12	10 / 12	10 / 12	10 / 12	10 / 12	10 / 12
Residual capacity at max height	kg	4900	4900	4900	4800	4600	4400	3800	3100

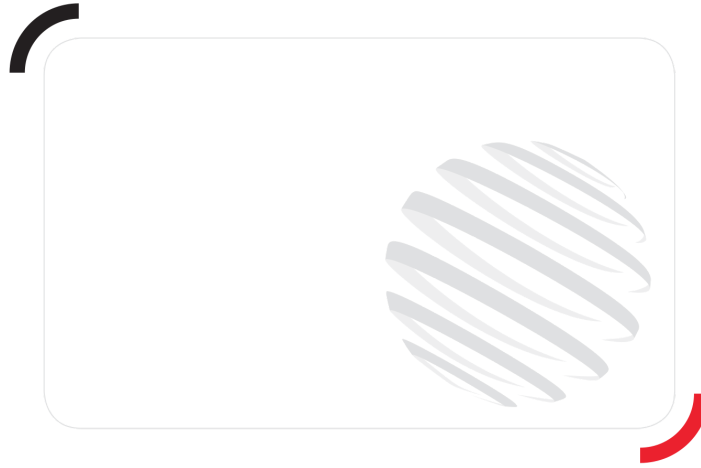

Head Office

B.P. 249 - 430 rue de l'Aubinière

44150 Ancenis Cedex - France

Tel: +33 (0)2 40 09 10 11 - Fax: +33 (0)2 40 09 10 97

www.manitou.com



This publication provides a description of the configuration versions and options for Manitou products, which may differ for equipment. The equipment presented in this brochure may be part of a series, as an option, or it may not be available, depending on the versions. Manitou reserves the right, at any time and without notice, to amend the specifications described and represented. The specifications provided do not bind the manufacturer. For more details, please contact your Manitou agent. This is not a contractually binding document. The presentation of the products is not contractually binding. List of specifications non-exhaustive. The logos as well as the visual identity of the company are owned by Manitou and cannot be used without authorisation. All rights reserved. The photos and diagrams contained in this brochure are only provided for consultation and information purposes.

MANITOU BF SA - Limited company with board of directors - Share capital: 39,668,399 euros - 857 802 508 RCS Nantes