

Technical sheet :

# MI 35 G

---



	Technical characteristics		Metric
1.1	Manufacturer		Manitou
1.2	Model Name		MI 35 G
1.3	Power source		Lpg
1.4	Operator type		Sitting
1.5	Max. capacity	Q	3500 kg
1.6	Load centre of gravity	c	500 mm
1.8	Load distance, centre of drive axle to fork	x	485 mm
1.9	Wheelbase	y	1700 mm
	<b>Weight</b>		
2.1	Service weight		4740 kg
2.2	Weight on front axle (laden) / rear axle (laden)		7260 kg / 980 kg
2.3	Weight on front axle (Unladen) / rear axle (Unladen)		1775 kg / 2965 kg
	<b>Wheels</b>		
3.1	Tyres type		PPS
3.2	Dimensions of front wheels		28-9-15 12
3.3	Dimensions of rear wheels		6.50-10 10
3.5	Number of front wheels / rear wheels		2 / 2
3.5.2	Number of drive wheels		2
3.6	Front wheel gauge	b10	1005 mm
3.7	Rear wheel gauge	b11	975 mm
	<b>Dimensions</b>		
4.1	Tilt of Mast Forward (deg) / Backward (deg)	$\alpha / \beta$	6 / 12
4.12	Height of towing bar (coupling height)	h10	360 mm
4.19	Overall length	l1	3935 mm
4.20	Length to face of forks	l2	2785 mm
4.21	Overall width	b1	1225 mm
4.21	Overall width - Single wheels	b1	1225 mm
4.22	Forks section / width / length	s / e / l	50 mm x 122 mm / 1150 mm
4.23	Fork carriage ISO 2328 (class/form) A/B		3A
4.24	Fork carriage width	b3	1100 mm
4.31	Ground clearance below mast	m1	130 mm
4.32	Ground clearance at centre of wheelbase	m2	200 mm
4.33	Aisle Width for pallets 1000 x 1200 crossways	Ast	4195 mm
4.34	Aisle width for 800 x 1200 pallet lengthways	Ast	4395 mm
4.35	Turning radius	Wa	2510 mm
4.36	Internal turning radius (over tyres)	b13	160 mm
4.7	Height of overhead guard (cabin)	h6	2130 mm
4.8	Seat height/stand height	h7	1215 mm
	<b>Performances</b>		
5.1	Travel speed (laden / unladen)		17 km/h / 17.50 km/h
5.2	Lifting speed (laden / unladen)		0.40 m/s / 0.52 m/s
5.3	Lowering speed (laden / unladen)		0.47 m/s / 0.38 m/s
5.5	Drawbar pull (Laden / Unladen)		1750 daN / 1100 daN
5.7	Gradeability (laden / unladen)		18 % / 20 %
5.10	Service brake		Hydraulic
	<b>Engine</b>		
6.4	Battery		0 V
7.1	Engine brand / model		GCT (ex-Nissan) / K25
7.2	Engine power according to ISO 1585		35 kW
7.3	Rated speed		2400 rpm
7.4	Number of cylinders / Capacity of cylinders		4 - 2488 cm <sup>3</sup>
	<b>Miscellaneous</b>		
8.2	Working hydraulic pressure for attachments		160 bar
8.3	Oil flow rate for attachments		72 l/min
8.4	Measured/guaranteed mean noise level at the ear of the operator		< 80 dB
8.4	Sound level at the driver's ear according to DIN 12 053		80 dB

## MI 35 G - Dimensional drawing

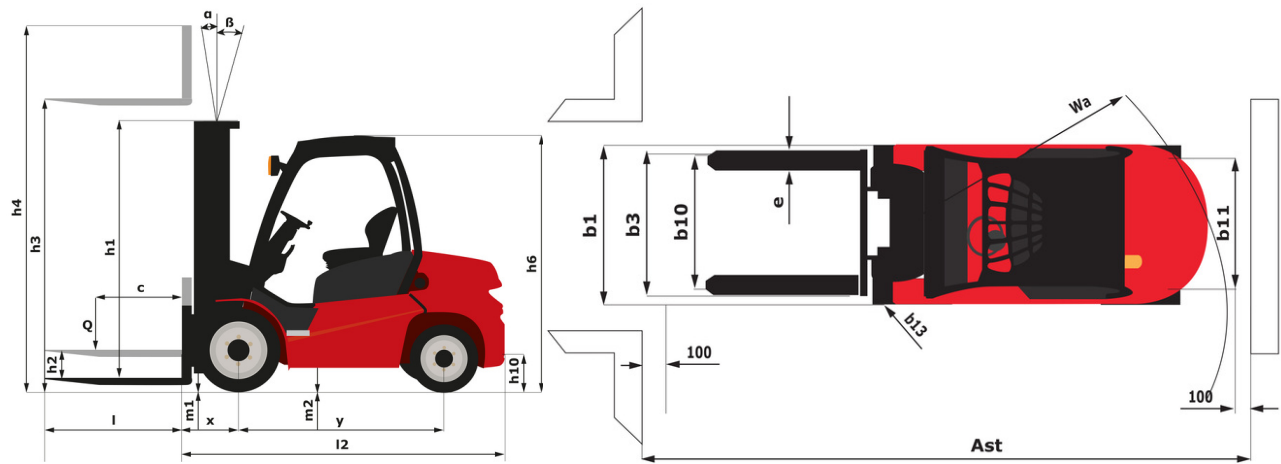

## Characteristics of masts and residual capacities

Duplex with total visibility		FVD 33	FVD 37	FVD 40
h2 - Free lift	mm	145	145	145
h1 - Height mast lowered *	mm	2315	2565	2715
h3 - Lifting Height	mm	3300	3700	4000
h4 - Height mast extended *	mm	4115	4515	4815
α / β - Mast inclination (front / rear)	°	6 / 12	6 / 12	6 / 12
Residual capacity without attachment (Industrial load chart)	kg	3500	3500	3500
Residual capacity with integrated side shift (Industrial load chart)	kg	3500	3500	3500
Height at max capacity	mm	3300	3700	4000
Height at max capacity with integrated sideshift	mm	3300	3700	4000
Height at max capacity Fork positioner + DL	mm	3300	3700	4000

Duplex with free lift		FLD 33	FLD 37	FLD 40
h2 - Free lift	mm	1500	1700	1850
h1 - Height mast lowered *	mm	2330	2530	2680
h3 - Lifting Height	mm	3300	3700	4000
h4 - Height mast extended *	mm	4130	4530	4830
α / β - Mast inclination (front / rear)	°	6 / 12	6 / 12	6 / 12
Residual capacity without attachment (Industrial load chart)	kg	3500	3500	3500
Residual capacity with integrated side shift (Industrial load chart)	kg	3500	3500	3500
Height at max capacity	mm	3300	3700	4000
Height at max capacity with integrated sideshift	mm	3300	3700	4000
Height at max capacity Fork positioner + DL	mm	3300	3700	

Free lift triplex		FLT 43	FLT 45	FLT 47	FLT 48	FLT 50	FLT 55	FLT 60	FLT 65
h2 - Free lift	mm	1385	1435	1985	2135	1485	1535	1585	1735
h1 - Height mast lowered *	mm	2215	2265	2815	2965	2315	2365	2415	2565
h3 - Lifting Height	mm	4300	4500	6000	4800	5000	5500	6000	6500
h4 - Height mast extended *	mm	5130	5380	6880	7330	5530	5630	5830	6330
α / β - Mast inclination (front / rear)	°	6 / 6	6 / 6	3 / 6	3 / 6	6 / 6	6 / 6	6 / 6	3 / 6
Residual capacity at max height	kg			3300	3300	3000	2200	1600	1500
Residual capacity without attachment (Industrial load chart)	kg	3450	3400	3300	3300	3000	2200	1600	1500
Residual capacity with integrated side shift (Industrial load chart)	kg	3450	3300	3200	3200	2900	2100	1500	1400
Height at max capacity	mm	4000	4000	4000	4000	4000	4000	4000	4000
Height at max capacity with integrated sideshift	mm	4000	4000			4000			
Height at max capacity Fork positioner + DL	mm	4000	4000						

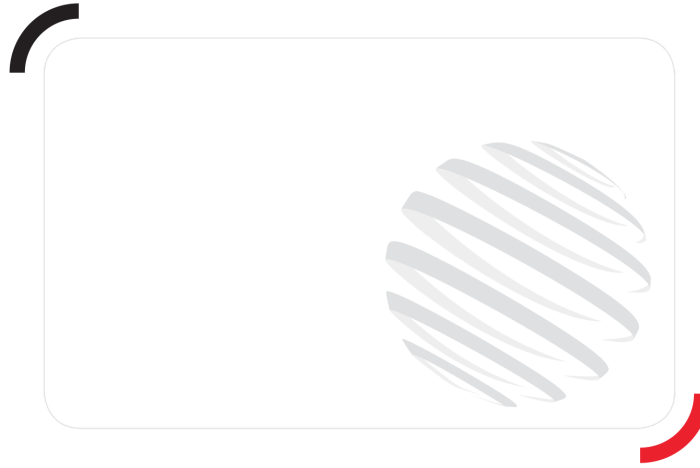

**Head Office**

B.P. 249 - 430 rue de l'Aubinière

44150 Ancenis Cedex - France

Tel: +33 (0)2 40 09 10 11 - Fax: +33 (0)2 40 09 10 97

[www.manitou.com](http://www.manitou.com)



This publication provides a description of the configuration versions and options for Manitou products, which may differ for equipment. The equipment presented in this brochure may be part of a series, as an option, or it may not be available, depending on the versions. Manitou reserves the right, at any time and without notice, to amend the specifications described and represented. The specifications provided do not bind the manufacturer. For more details, please contact your Manitou agent. This is not a contractually binding document. The presentation of the products is not contractually binding. List of specifications non-exhaustive. The logos as well as the visual identity of the company are owned by Manitou and cannot be used without authorisation. All rights reserved. The photos and diagrams contained in this brochure are only provided for consultation and information purposes.

MANITOU BF SA - Limited company with board of directors - Share capital: 39,668,399 euros - 857 802 508 RCS Nantes