



Reel Auggie® / Reel Commercial TMR Mixers
3100 / RA 100 SERIES / RC 200 SERIES / RC 3120



MAXIMIZE EFFICIENCY AND MIXING PERFORMANCE

QUALITY PERFORMANCE WITH THE LOWEST POSSIBLE INPUT COSTS IS THE GOAL OF EVERY OPERATION. THE FAST, GENTLE MIXING OF KUHN KNIGHT REEL MIXERS HELPS MAXIMIZE EFFICIENCY AND MINIMIZE EXPENSE. THE REEL AND AUGER DESIGN ELIMINATES MUCH OF THE FORCE AND PRESSURE SEEN WITH OTHER MIXER TYPES. THE RESULT IS LOW HORSEPOWER REQUIREMENTS AND LESS FUEL CONSUMPTION FOR A MORE ECONOMICAL OPERATION.



ANNUAL SAVINGS

Fuel savings based on lower power requirement and shorter mix time compared to similar sized load in a vertical mixer. Estimated savings based on three hours of use per day using diesel fuel at \$4.00 per gallon. Actual savings may vary depending on application.

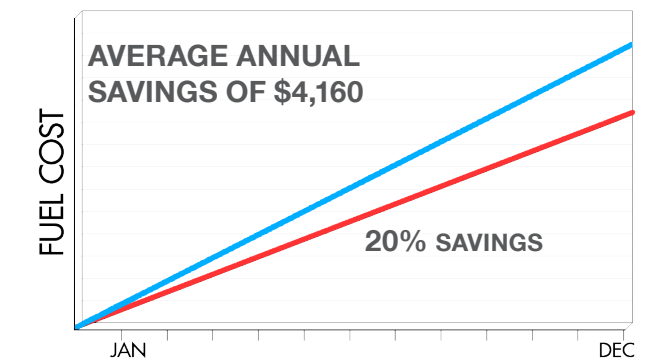

Summary

- The Reel Advantage 4-7
- 3100 Series 8
- RA 125 & 130 9
- RA 136 & 142 10-11
- RC 200 Series 12-13
- RC 3120 14-15
- Stationary & Truck Models 16-17
- Options 18-20
- Specifications 21-23

Models	Mixing Capacity	Reel Type	Available Configurations
3115	150 ft ³ (4.2 m ³)	Standard	Trailer, Stationary
3120	220 ft ³ (6.1 m ³)	Standard	Trailer, Truck, Stationary
RA 125	250 ft ³ (7.1 m ³)	Standard or Helix	Trailer, Truck, Stationary
RA 130	300 ft ³ (8.5 m ³)	Standard or Helix	Trailer, Truck, Stationary
RA 136	360 ft ³ (10.2 m ³)	Helix	Trailer, Truck, Stationary
RA 142	420 ft ³ (11.9 m ³)	Helix	Trailer, Truck, Stationary
RC 250	500 ft ³ (14.2 m ³)	Helix	Trailer, Truck, Stationary
RC 260	600 ft ³ (17 m ³)	Helix	Trailer, Truck, Stationary
RC 270	700 ft ³ (19.8 m ³)	Helix	Trailer, Truck, Stationary
RC 295	950 ft ³ (26.9 m ³)	Helix	Trailer, Truck, Stationary
RC 3120	1,200 ft ³ (34 m ³)	Helix	Trailer, Truck

THE REEL ADVANTAGE

Reel mixers are ideal for dairy and beef producers mixing rations with high percentages of processed roughages or distillers grains. The reel thoroughly mixes rations gently without causing excessive damage to the feed ingredients, preserving desired ingredient particle length or size for your herd.

Reel mixers provide the ultimate versatility. From the popular, multi-purpose trailer models, to the fast, convenient transport offered by truck mounted machines, to stationary models that are ideal for central mixing, there is a mixer to meet the needs of any operation. These machines also offer a low standard loading height for easy loading with skid steers.

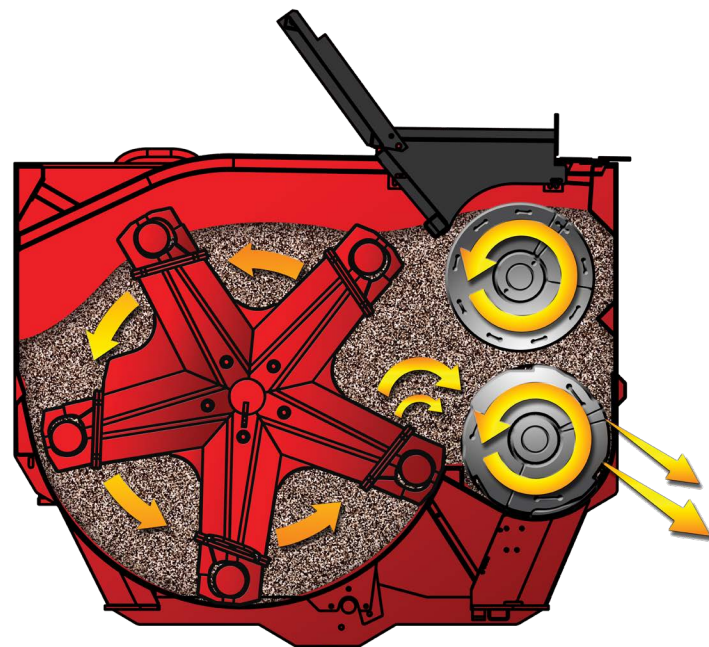

SUPERIOR FEED MOVEMENT

- The large reel gently lifts material up into the side augers for excellent side-to-side movement.
- The upper auger moves material rearward, while the lower auger moves material forward for end-to-end mixing. This helps feed continually charge the door during discharge.



CONSISTENT MIXING AND DISCHARGE

KUHN Knight reel mixers provide a consistent mix, even with small batches, for a balanced ration from beginning to end. Their quick, even discharge with a more complete cleanout helps save time and maximizes efficiency.



SIMPLE FEEDING

With a high discharge point, these mixers allow for the use of a simple slide tray in most feeding situations. The long tray makes it easy to feed deeper into most bunks, while preventing feed loss from the wind. This dependable, low-cost option also results in less maintenance.



THE ENHANCED REEL DESIGN

The Helix® reel has a robust build and has been thoroughly tested to withstand the most challenging conditions. The design of the reel crossbars evens the pressure across the length of the reel for smoother, more consistent operation. It also engages with the feed more smoothly.

OPEN CENTER REEL

The open-center design eliminates obstructions in the reel and provides superior feed movement and unparalleled mixing action. The benefits are unmistakable, with faster, more consistent mixing, improved load leveling, optimized mixer space utilization and fewer dead spots for ultimate ration quality.

SUPERIOR MIXING OF WET BY-PRODUCT RATIONS

A mix bar runs diagonally across the center of the reel to help ensure consistent feed movement throughout the entire mixing chamber. The reel crossbars keep feed moving efficiently around the outside of the chamber. The secondary mechanical mixing action from the mix bar provides a fast and thorough mix even in wet, heavy rations with large amounts of distillers grains.

IMPROVED LOAD LEVELING

With all potential obstacles removed from the center of the reel, feed is free to flow unobstructed from one end of the mixing chamber to the other. This greatly improves the end-to-end mixing action and helps eliminate uneven filling for optimum load leveling in any ration. Even leveling allows consistent use of the full capacity of the machine for maximum efficiency.

FASTER, MORE EVEN UNLOADING AND CLEANOUT

Cleanout speed is a key factor that can limit feeding efficiency, extending feeding cycles and ultimately costing valuable time and money. The open-center design provides fast, consistent unloading, with quicker, more complete cleanout than competitive models. The result is optimum performance, allowing the operator to move on to the next batch faster.

ENHANCED PERFORMANCE FOR GRAIN AND ROUGHAGE RATIONS

The cutting-edge design has been extensively tested with the toughest beef and dairy rations. From dry, dusty materials, to wet, heavy rations, the Reel Auggie® mixers with Helix® reel technology set a standard for quality performance and superior mixing to meet the needs of even the most demanding producers.

TIME-TESTED DESIGN

KUHN Knight 3100 Series Reel Auggie® mixers offer the same quality mixing performance and dependable service that has been their hallmark. The time tested, standard reel and auger design provides a fast, thorough mix for a fluffy, palatable ration. Quality components and a rugged design help ensure reliability and long life. These mixers are available in trailer, truck and stationary models with capacities ranging from 150 to 220 cubic feet.

Note: The 3115 is not available as a truck-mounted model



REPUTABLE RELIABILITY – NOW WITH A TWIST

Two new models have been added to the RA 100 Series Reel Auggie® mixers – The RA 125 & RA 130. These 250 and 300 cubic foot machines continue the tradition of outstanding durability and performance, with proven features that stand out from the competition. After many requests from farmers like you, this capacity range of mixers is now available with the standard reel or the patented Helix reel. The Helix reel, with its open-center design, offers faster, more consistent mixing and improved load leveling with any ration and excels mixing rations with high percentages of byproducts and/or roughages. The RA 125 and RA 130 are available in trailer, truck and stationary configurations.



WELDED AUGER SHAFTS

Auger shafts on both the upper and lower augers are fused to the auger drive flange with a weld, providing a weld joint as strong as the shaft. This results in superior strength and durability over other conventionally welded shafts.



FRONT OIL BATH

The easy-access front oil bath on the RA 125 & RA 130 keeps drive chains lubricated and ensures a long drive life. Improved sealing eliminates oil leaking out the panel and door keeping the machine clean. The roller chain drive is durable enough to handle batches with the heaviest, wettest, stickiest rations. Spring-loaded chain tensioners ensure proper chain tension and alignment. The rugged chain continuously runs through the enclosed oil bath, constant lubrication leads to added protection and longer life.



STANDARD REEL

The standard reel is a time-tested design going back to the original development of the reel mixers. This is the lower cost reel option and performs extremely well in free-flowing rations with a lower amount of roughage. Those of you mixing a high amount of ethanol byproducts or higher amounts of roughages should consider upgrading to the Helix reel.

The standard reel consists of a main center tube supporting four spring-loaded straight bars. The springs serve as protectors from obstructions to both the reel and the side wall. Poly wipers on two of the bars assist with cleanout especially with granular, free-flowing materials.

3115 & 3120 are only available with standard reel

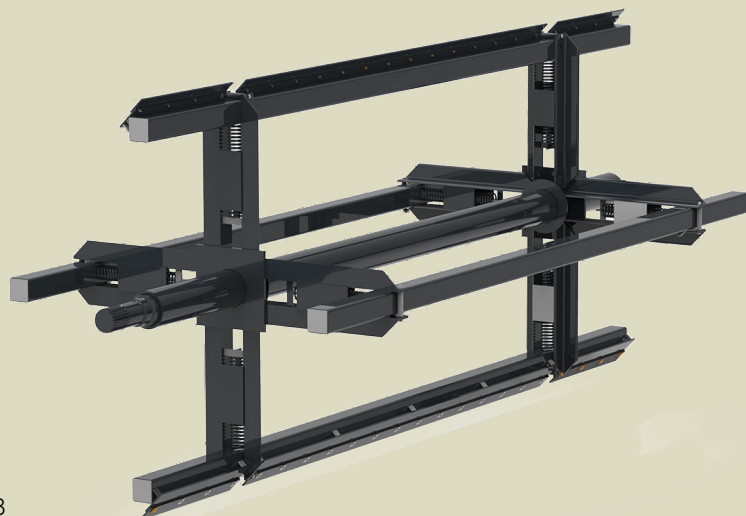

HELIX REEL

The flexibility of choosing between a standard or Helix reel is a true advantage on the new RA 125 & RA 130. The standard reel does an excellent job mixing, but if you're mixing stickier or higher-roughage rations, the open-center Helix reel is your answer.

The cutting-edge design has been extensively tested with the toughest beef and dairy rations. A mix bar runs diagonally across the center of the reel to help ensure consistent feed movement throughout the entire mixing chamber. The reel crossbars keep feed moving efficiently around the outside of the chamber. The secondary mechanical mixing action from the mix bar provides a fast and thorough mix even in wet, heavy rations with large amounts of distillers grains.

Only available as an option on the RA 125 & RA 130



PROVEN RELIABILITY

The KUHN Knight RA 136 and RA 142 Reel Auggie® mixers provide the ultimate versatility, durability and performance. These mixers are ideal for dairy and beef producers mixing rations with high percentages of processed roughages or distillers grains. The Helix® reel, with its open-concept design, offers faster, more consistent mixing and improved load leveling with any ration. Strengthened body and drive components provide superior dependability and long life.

From the popular, multi-purpose trailer models, to the fast, convenient transport offered by truck mounted machines, to stationary models that are ideal for central mixing, there is a mixer to meet the needs of any operation. These machines also offer a low standard loading height for easy loading with skid steers.



BOLTED AUGER FLANGES

Bolted flanges on the upper and lower augers provide strong connections between the auger tubes and drive shafts for superior durability. They also allow for a single-piece front panel that gives added strength and provides a clean look.



LOWERED DROP SIDE

The lowered right side, with a 15" drop, provides a lower side height to provide easier loading, while the two-position axle setting allows versatility to match your unique needs. The upper setting drops the overall height of the machine by 6" for easier loading with skid steers.



DEPENDABLE DRIVE

The roller chains have been sized for increased durability and long service life. The entire heavy-duty chain and sprocket drive run continually in an enclosed oil bath for added protection and longer life. The rear location of the oil bath allows for convenient service.



HEAVY-DUTY DISCHARGE DOOR

The door discharge and pivot have been redesigned and strengthened for extended service life. The linkage incorporates two ball pivots for smooth operation.



UPGRADED REAR DRIVE SHAFT

A heavy, 1 1/2" rear drive shaft provides added strength for dependable service, even in rations heavy in distillers grains.

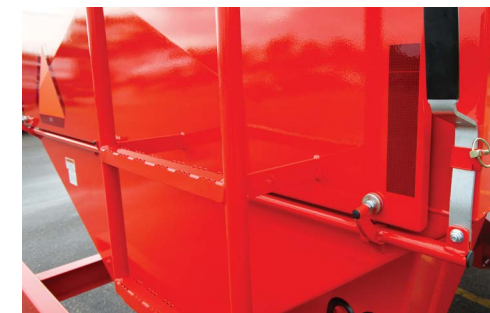

EASY ACCESS DOOR

The new single-handed latch provides easy access to the oil bath. An improved seal keeps oil in, and dirt and debris out, to help minimize wear on drive components and maintain a cleaner appearance.

OUTPERFORM EXPECTATIONS

KUHN Knight RC 200 Series Reel Commercial mixers provide superior durability and performance with innovative options that separate them from the competition. The Helix® reel, with its open-center design, offers fast, consistent mixing and superior load leveling with any ration. The enhanced reel design optimizes the mixing of wet by-product rations, but through extensive testing has proven to provide quality performance in all rations. The heavy-duty drive option offers extended life, in even the most extreme use cycles, and provides the ability to mix the heaviest feedstuffs. These features, combined with the versatility and low horsepower requirements that are the hallmark of the reel and auger design, put these RC models at the head of their class! With truck, trailer and stationary models, and capacities ranging from 500 to 950 cubic feet, there's a machine to fit every feeding situation.



SLIDE TRAY LINKAGE

The discharge door and linkage have been reinforced to provide reliable service and long life. The slide tray linkage has also been relocated and improved. This change provides increased adjustability to adapt to different feeding situations and eliminates the possibility of the tray extending over center when opened.



RUGGED UNDERCARRIAGE OPTIONS

Straight-single and walking-tandem bogie axle options are available for trailer models, providing flexibility for varied terrain. Both feature heavy-duty spindles and hubs for maximum durability and long life.



STANDARD OR LOWERED RIGHT SIDE

The option of a standard or lowered right side allows customers the flexibility to choose the setup that best matches the needs of their operation.

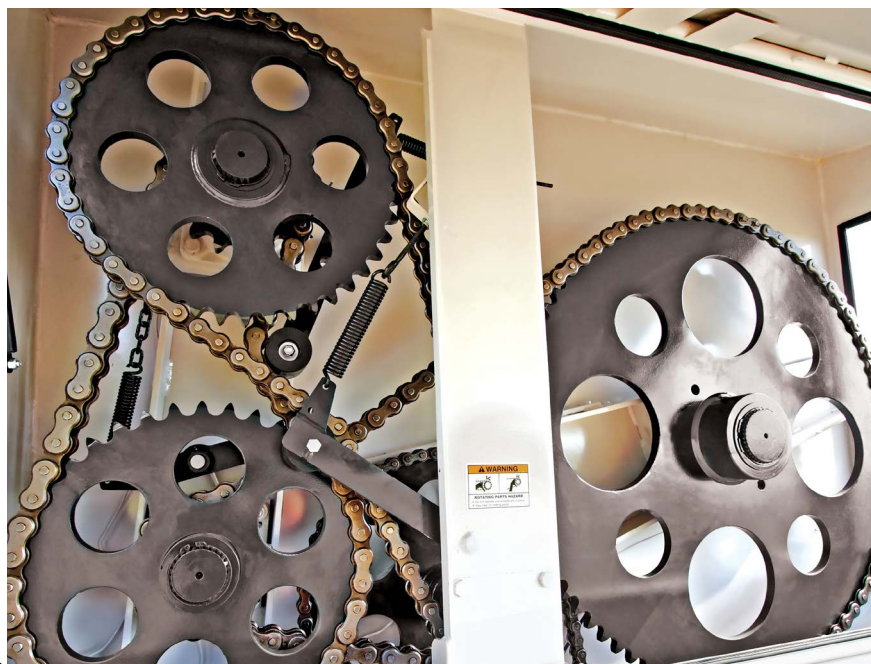

HD DRIVE

A heavy-duty drive provides heavier chains throughout and a larger diameter countershaft and bearings for added strength and extended life in the toughest mixing conditions and heaviest use cycles. *Optional on RC 250 & 260*

The splined drive shafts allow a strong, reliable torque transfer and provide easier sprocket alignment and maintenance.

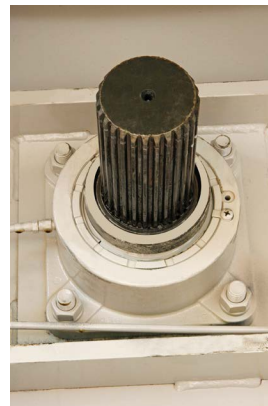

TAILOR YOUR MACHINE TO MEET YOUR RATION'S NEEDS



GRAIN-AUGER

The grain-auger option provides gentle handling of more delicate feeds like flaked corn to maintain ration quality and prevent fines.



ROUGHAGE-AUGER

The roughage-auger option features notched, sectional flighting with welded-in, self-sharpening, hardened knives for better hay handling.

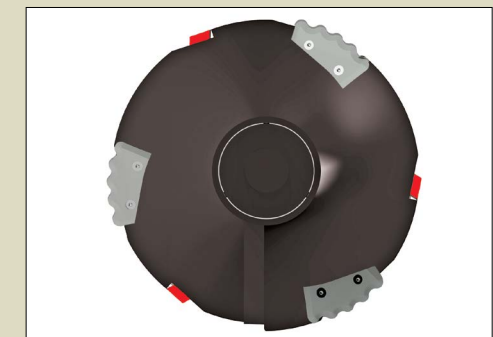

ROUGHAGE MAXX®

With the Roughage Maxx System, scalloped knives are added to the lower augers to maximize hay processing. The knives provide a more consistent particle length and more even blending of the ration.



NEXT GENERATION CATTLE FEEDING

The KUHN Knight RC 3120 is the newest addition to the KUHN Knight reel mixer lineup. Available in a trailed or truck-mount configuration, the RC 3120 boasts a mixing capacity of 1,200 ft³, making it the largest reel mixer offered by KUHN and the largest trailed reel mixer on the market. The large mixing tub features the famous Helix reel, providing fast, thorough mixing of a wide variety of already processed materials. A new sophisticated software provides unmatched automation through KUHN's new truck controls providing the operator simple control over the machine. The RC 3120 not only has the brains for next-generation cattle feeding, but also possesses the brawn necessary for demanding applications. No chains and sprockets are used on the RC 3120 drive, only heavy-duty planetary gearboxes used on vertical mixer augers and concrete mixers.

DIRECT GEARBOX DRIVE

With the large capacity of the RC 3120, a robust drive is necessary for reliable operation. Instead of using a traditional chain and sprocket drive system, the RC 3120 features a direct planetary gearbox drive. The direct planetary drive offers the capability to separate reel and auger control, providing automation capabilities in addition to providing a heavy-duty drive solution for the largest of KUHN's reel mixer line.

HEAVY-DUTY DRIVE COMPONENTS

Drive components on the RC 3120 are built to last in high-use applications. Each auger is driven by a planetary gearbox similar to the planetaries used on the VT Vertical Mixers. The reel drive planetary is one of the highest rated gearboxes in a planetary line that is used predominantly in concrete mixer truck applications. The drive components on the RC 3120 are comparable to bringing a twin-auger vertical mixer and a concrete mixer together and combining them in one machine!



ENHANCED TRUCK MOUNT CONTROL



NEW MIXING AUTOMATION CAPABILITY

Offering separate, direct drive of the augers and reel provides new opportunities for automation in the RC 3120. An automatic loading mode can be used to automatically turn the augers and reel on, saving on mixer wear and fuel usage. Mix counter functionality can be set up to turn off the mixing components after a designated time of loading the last ingredient. When unloading, the augers can be controlled independently of the reel as well to place precise amounts of feed and reduce machine wear and fuel use.



UPDATED TRUCK CONTROLS

Improved, easy to use truck controls provide operators with a comfortable, simple operation solution. The RC 3120 offers increased capabilities while at the same time becoming simpler for the operator to run. The in-cab display portion of the updated truck controls allows operators to monitor machine performance and detect any issues that may arise. Through the display, managers can adjust automation settings, monitor machine use for maintenance purposes, and have an assistant to troubleshooting any issues.

MAXIMIZE FEEDING EFFICIENCY

Whether mixing wood chips or a ration for your livestock, KUHN Knight reel mixers are available in a stationary configuration and are ideal for maximizing feeding efficiency and mixer throughput on any operation. Stationary mixers are perfect for producers with centralized feed storage and multiple mixers running throughout the day. By incorporating centralized mixing, one loader operator is often able to keep multiple mixers constantly running, greatly increasing mixing capacity and reducing labor.



Also, with the addition of delivery boxes, the mixers do not experience the downtime from driving location to location, and in turn do not receive the additional stress which can be seen from constant travel.

STATIONARY MIXERS:

- ✓ Allow for use of a delivery box that can deliver feed more efficiently, especially with longer travel distances
- ✓ Decrease cycle time since feed can continue to mix while the delivery truck is delivering feed to your livestock
- ✓ Minimize stress seen from constant travel



TRUCK MOUNT OPTIONS

Kuhn North America offers complete factory mounting of mixer to truck chassis. In addition, we are able to alter customer supplied truck chassis to fit your specific feeding needs through modifications in our truck shop.



DRIVE SELECTION FOR MAXIMUM PERFORMANCE

MECHANICAL DRIVE

Due to the low horsepower requirement of the reel auger design, a mechanical drive powered by a transmission PTO works well in many feeding situations, at a lower cost than alternative drive options. Mechanical drives are available in a number of different configurations, including front and mid-unit gearbox mounting in order to match up to nearly any truck chassis.



HYDROSTATIC DRIVE

In addition to mechanical drives, the RC 200 Series is also available with a hydrostatic drive. This hydrostatic system is driven off of either a front engine (FEPTO) or rear engine (REPTO) power take-off. Driven off of the engine instead of transmission, hydrostatic drives allow for the mixer speed to be controlled independent of ground speed. The hydrostatic drives also allow for gentler mixer startup, which is especially important in larger units mixing heavier loads.



MULTIPLE DISCHARGE OPTIONS



SLIDE TRAY

The high discharge point of Reel Auggie mixers allows use of the simple, dependable, low-cost slide tray in most applications. It has simple hydraulic controls and the long discharge tray reaches deeper into bunks to prevent feed loss from the wind. Magnets are standard on slide tray.

Available on all models



CHAIN AND SLAT CONVEYOR

Rugged chain and slat conveyor options provide the ultimate in durability and long life. Heavy-duty components ensure reliable service and multiple conveyor length options offer unmatched flexibility to match different feeding situations.

Available on all models except RC 295 & RC 3120



3-AUGER DISCHARGE

The 3-auger discharge allows adjustment for feeding into higher bunks. It has a simple, hydraulic drive that provides smooth, even discharge. Long lasting, poly chute liners help prevent rust and limit wear. The 3-auger discharge comes standard with fixed tip-off and built-in magnets.

3100 and RA models only

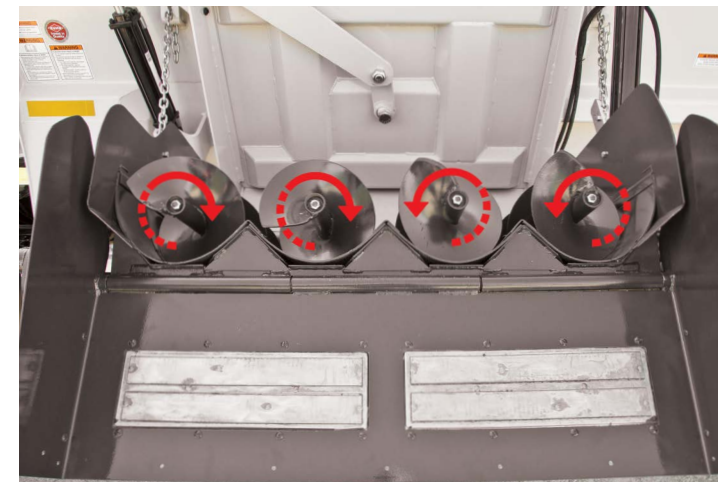

4-AUGER DISCHARGE

Counter-rotating augers bring the feed to the center of the discharge to increase overall capacity and provide a smooth, even discharge for all ration types. The 4-auger discharge comes standard with power tip-off and built-in magnets.

RC 250, 260 & 270 models only



REMOVABLE AUGERS & POLY LINERS

The discharge augers are held on by a single lock nut making them firmly attached, yet simple to remove for easy cleaning and service. Long-lasting, replaceable polyethylene chute liners prevent rust and limit wear.

4-auger discharge feature



SIMPLIFIED DRIVE

As with the main auger drive, the discharge auger shafts are splined for a more positive power transfer and longer service life. The simplified drive design, featuring only two chains and a remote grease bank, results in easy service and maintenance.

4-auger discharge feature

EFFECTIVE HAY HANDLING



ROUGHAGE MAXX®

With the Roughage Maxx System, scalloped knives are added to the lower auger to maximize hay processing. The knives provide a more consistent particle length and more even blending of the ration. The result is a more uniform and palatable ration with reduced sorting for overall better feed efficiency.



HAY MAXX®

The Hay Maxx System provides enhanced processing of a wide variety of materials. Hay and other bulky materials can be placed on the pan, allowing them to be preprocessed by the upper auger before entering the mixing chamber. Additional aggressive, hardened-edge knives are added to the upper auger that help process the hay to the proper length before entering the mixing chamber.



ADDITIONAL OPTIONS



SCALE SYSTEMS

Different scale brands, models and options are available for all types of operations, ranging from the basic to high-end feed tracking programs. Optional remote indicators are available for placement that will allow easier viewing.

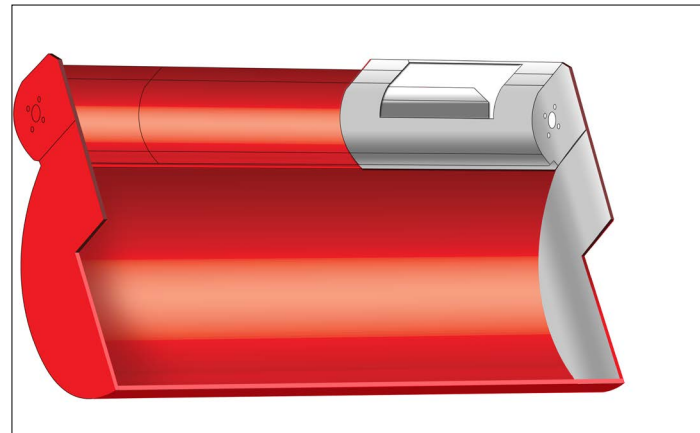

PARTIAL OR FULL STAINLESS STEEL LINER

The partial liner covers the most critical wear areas in the mixer and provides added protection and longer life. The full liner completely covers all of the high-wear areas for unmatched dependability and long service. Both provide added protection when mixing more abrasive or corrosive materials resulting in longer life of the unit shell.

3115 and 3120 are only available with full stainless steel liner

REEL TMR MIXERS STATIONARY MODELS

Technical Specifications										
	3115	3120	RA 125	RA 130	RA 136	RA 142	RC 250	RC 260	RC 270	RC 295
Capacity	147 ft ³ (4.2 m ³)	216 ft ³ (6.1 m ³)	250 ft ³ (7.1 m ³)	300 ft ³ (8.5 m ³)	360 ft ³ (10.2 m ³)	420 ft ³ (11.9 m ³)	500 ft ³ (14.2 m ³)	600 ft ³ (17 m ³)	700 ft ³ (19.8 m ³)	950 ft ³ (26.9 m ³)
Maximum Net load	4,410 lbs (2,000 kg)	6,480 lbs (2,939 kg)	7,500 lbs (3,402 kg)	9,000 lbs (4,082 kg)	10,800 lbs (4,900 kg)	12,600 lbs (5,715 kg)	15,000 lbs (6,804 kg)	18,000 lbs (8,165 kg)	21,000 lbs (9,525 kg)	28,500 lbs (12,927 kg)
Overall Height	64" (163 in)		69" (175 cm)		87" (221 cm)		81" (206 cm)		99" (251 cm)	
Mixing Chamber Length	84" (213 cm)	120" (305 cm)	120" (305 cm)	144" (366 cm)	132" (335 cm)	156" (396 cm)	168" (427 cm)	198" (503 cm)	228" (579 cm)	216" (549 cm)
Overall Width - Mixer Only (No Discharge)	88" (224 cm)		92" (234 cm)		108" (274 cm)		114" (290 cm)		126" (320 cm)	
Reel Speed	4.5 RPM	5 RPM	8 RPM		6.25 RPM		5.7 RPM		5.2 RPM	
Reel Arms	4		4		5		5		5	
Lower Auger Flighting Diameter	16" (41 cm)		18" (46 cm)		20" (51 cm)		24" (61 cm)		28" (71 cm)	
Lower Auger Flighting Thickness - Sectional	3/8" (1 cm)		3/8" (1 cm)		1/2" (1.3 cm)		5/8" (1.6 cm)		5/8" (1.6 cm)	
Lower Auger Tube - Outside Diameter	4" (10.2 cm)		5 9/16" (14 cm)		5 9/16" (14 cm)		6 5/8" (17 cm)		8 5/8" (22 cm)	
Lower Auger Drive Shaft Diameter	2" (5.1 cm)	2 1/2" (6.4 cm)	2 1/2" (6.4 cm)		3" (8 cm)		3 1/2" (8.9 cm)		5" (12.7 cm)	
Upper Auger Flighting Diameter	14" (36 cm)		14" (36 cm)		20" (51 cm)		22" (56 cm)		24" (61 cm)	28" (71 cm)
Upper Auger Flighting Thickness	3/8" (1 cm)		3/8" (1 cm)		1/4" (0.6 cm)		1/2" (1.3 cm)		1/2" (1.3 cm)	
Upper Auger Tube - Outside Diameter	4" (10.2 cm)		5 9/16" (14 cm)		8 5/8" (22 cm)		6 5/8" (17 cm)		8 5/8" (22 cm)	
Upper Auger Drive Shaft Diameter	2" (5.1 cm)	2 1/2" (6.4 cm)	2 1/2" (6.4 cm)		3" (8 cm)		3 1/2" (8.9 cm)		4" (10.2 cm)	
Reel Diameter	52" (132 cm)		60" (1.5 m)		68" (173 cm)		70" (178 cm)		84" (213 cm)	
Reel Driveshaft Diameter	3" (8 cm)	3 1/2" (9 cm)	3 1/2" (8.9 cm)		4" (10 cm)		5" (13 cm)		8" (20 cm) Tube	
Length - Haypan	84" (213 cm)	96" (244 cm)	96" (244 cm)		96" (244 cm)	120" (305 cm)	120" (305 cm)	144" (366 cm)		144" (366 cm)
Lower Auger Tube - Wall Thickness	1/4" (0.6 cm)	5/16" (0.8 cm)	3/8" (1 cm)		3/8" (1 cm)		7/16" (1.1 cm)		1/2" (1.3 cm)	
Upper Auger Tube - Wall Thickness	1/4" (0.6 cm)		3/8" (1 cm)		5/16" (0.8 cm)		7/16" (1.1 cm)		1/2" (1.3 cm)	
Roller Chain Drive	50-60-80	60H-80-100H	80-80H-100H		80-100-120		80-100-120-140		100-120-140-140	100-140-160-200
Roller Chain Drive - Heavy Duty							100-120-140-140			
Unit Weight	2,850 lbs (1,293 kg.)	4,809 lbs (2,181 kg)	6,600 lbs (2,994 kg)	7,280 lbs (3,302 kg)	9,310 lbs (4,223 kg)	9,720 lbs (4,409 kg)	12,990 lbs (5,892 kg)	14,800 lbs (6,713 kg)	18,500 lbs (8,391 kg)	21,300 lbs (9,662 kg)
Weighing System	4-point		4-point		4-point		4-point		4-point	
Door Opening Size	20"x16" (51x41 cm)	36"x 20" (91x51 cm)	36" x 20" (91x51 cm)		36"x20" (91x51 cm)		42"x22" (107x56 cm)		48"x26" (122x66 cm)	
Sidewall Thickness	9/64" (0.3 cm)		9/64" (0.3 cm)		9/64" (0.3 cm)		1/4" (0.6 cm)		1/4" (0.6 cm)	
Sidewall Thickness - Auger / Reel	9/64" (0.3 cm)		9/64" / 7 GA (0.3/0.5 cm)		9/64" / 7 GA (0.3/0.5 cm)		7 GA/1/4" (0.5/0.6 cm)		1/4" (0.6 cm)	
Stainless Steel Side Liner	7/64"		7/64"		7/64"		7/64"		7/64"	
End Panel Thickness - Front and Rear	9/64" (0.3 cm)		3/16" (0.5 cm)		3/16" (0.5 cm)		1/4" (0.64 cm)		1/4" (0.64 cm)	
Reel Hopper Thickness	7 GA (0.5 cm)		5/16" (0.8 cm)		5/16" (0.8 cm)		3/8" (1 cm)		3/8" (1 cm)	
Auger Hopper Thickness	1/4" (0.6 cm)		5/16" (0.8 cm)		5/16" (0.8 cm)		3/8" (1 cm)		3/8" (1 cm)	
Overall Length - With Motor Mount	120" (305 cm)	159" (404 cm)	161" (409 cm)	185" (470 cm)	184" (467 cm)	208" (528 cm)	226" (574 cm)	256" (650 cm)	286" (726 cm)	309" (785 cm)
Length Reduction - Less Motor Mount	12" (31 cm)	23" (58 cm)	21" (53 cm)		28" (71 cm)		36" (91 cm)		-	
Motor Mount to Center of Discharge Door	50" (127 cm)	65" (165 cm)	65" (165 cm)		60" (152 cm)		70" (178 cm)		-	
Overall Height - With Rails and Scales	64" (163 cm)		69" (175 cm)		87" (221 cm)		84" (213 cm)		95" (241 cm)	
Discharge Height - With Rails and Scales	16 1/2" (42 cm)	18" (46 cm)	18" (46 cm)		23" (58 cm)		26" (66 cm)		23" (58 cm)	
Height Reduction - Less Rails and Scales	7" (18 cm)		7" (18 cm)		14" (36 cm)		5 1/2" (14 cm)		9" (23 cm)	
Electric Motor Horsepower	7.5-10 hp (5.6-7.5 kW)	10 hp (7.5 kW)	20 hp (15 kW)		25 - 30 hp (18 - 22 kW)		50 hp (37 kW)	60 hp (45 kW)	70 hp (52 kW)	100 hp (75 kW)
Electric Motor RPM	1,800 RPM		1,800 RPM		1,800 RPM		1,800 RPM		1,800 RPM	
Discharge Door Control	Manual		Manual		Manual or Elec/Hyd.		Manual or Elec/Hyd.		Manual or Elec/Hyd.	

MyKUHN

THE LINK TO MY SUCCESS

MyKUHN is your online customer portal where you can access machine operator's manuals, parts catalog and more! The site is available on computer, phone or tablet, so you can access your fleet's information anywhere around the farm. Create an account and register your KUHN equipment today.

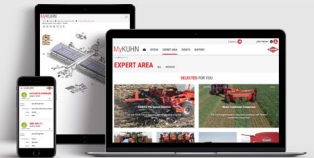

MORE PRODUCTS TO MEET YOUR NEEDS!



1. Mowers - 2. Tedders - 3. Round Balers - 4. Bale Processors - 5. Manure Spreaders - 6. Primary Tillage Systems

KUHN NORTH AMERICA, INC. | Corporate Headquarters | 1501 West Seventh Avenue - Brodhead, WI 53520

For more information about your nearest KUHN dealer,
visit our website www.kuhn.com

Information given in this document is only for informational purposes and is non-contractual. Our machines are in compliance with North American safety standards. In our literature, and for improved illustration of certain details, some safety devices may not be in operating position. When operating these machines, these devices must be operated in accordance with the requirements indicated in the operator's manuals and assembly manuals. We reserve the right to change any designs, specifications or materials listed without further notice. Machines and equipment in this document can be covered by at least one patent and/or registered design. Trademarks cited in this document may be registered in one or several countries.

Printed in USA 7065432US 1022 Copyright 2022 Kuhn North America, Inc.

