

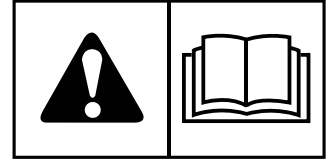

# ***OPERATOR'S MANUAL***

## **ISX2200 Series**

### **Zero-Turn Riding Mower**



<b>Model</b>	<b>Description</b>	<b>Model</b>	<b>Description</b>
5901843	ISX2200BVE2852SS	5901923	ISX2200BVE2861SS
5901845	ISX2200BVE2861SS	5901924	ISX2200BVE2852SS
5901846	ISX2200BVE2852SS AUS	5901927	ISX2200BVE2861SS AUS
5901847	ISX2200BVE2861SS AUS	5902025	ISX2200KAV2652SS
5901875	ISX2200BVE2852SS CAL	5902026	ISX2200KAV2661SS
5901877	ISX2200BVE2861SS CAL	5902027	ISX2200KAVE2652SS
5901977	ISX2200KAV2652SS	5902028	ISX2200KAVE2661SS
5901978	ISX2200KAV2661SS		
5901995	ISX2200KAVE2652SS		
5901996	ISX2200KAVE2661SS		

**This manual is available in Spanish. For a copy, contact your Ferris dealer or [www.ferrismowers.com](http://www.ferrismowers.com).  
Este manual está disponible en Español. Para obtener una copia, póngase en contacto con su  
distribuidor Ferris o [www.ferrismower.com](http://www.ferrismower.com).**

# Table of Contents:

<b>General Information</b> .....	<b>3</b>	Electronic Fuel Injection (EFI) System - EFI Models .....	32
<b>Identifying Your Unit</b> .....	<b>3</b>	Inspect Muffler and Spark Arrester.....	32
<b>Operator Safety</b> .....	<b>3</b>	Fuse Location and Identification.....	32
Safety Alert Symbol and Signal Words.....	3	Check / Fill Transmission Oil Level.....	32
California Proposition 65.....	4	Transmission Oil Filter Change.....	33
Operating Safely.....	4	Purging the Air from the Hydraulic System.....	33
Slope Identification Guide.....	6	Checking Tire Pressures.....	34
Safety Rules and Information.....	6	Lubrication.....	34
Safety Decals and Icons.....	11	Lubricating the ForeFront Suspension Control Arms.....	35
Safety Icons for Optional Jack Kit Accessory.....	16	Lubricating the Front Casters.....	35
Safety Interlock System.....	16	Servicing the Mower Blades.....	35
<b>Features and Controls</b> .....	<b>16</b>	Seat Adjustment (Suspension Seat).....	37
Control Functions and Locations.....	16	Ground Speed Control Lever Adjustment.....	37
Zero-Turn Rider Controls.....	16	Speed Balancing Adjustment.....	38
Instrument Control Panel.....	18	Cutting Height Adjustment.....	38
<b>Operation</b> .....	<b>20</b>	Foot Pedal Adjustment.....	39
Before First Time Operation.....	20	Floor Pan Removal & Installation.....	39
Checks Before Starting.....	21	Neutral Adjustment.....	39
Starting the Engine - Carbureted Models.....	21	Return-to-Neutral Adjustment.....	40
Starting the Engine - Fuel Injected Models.....	21	Neutral Lockout Adjustment.....	40
Starting the Engine - Kawasaki Fuel Injected Models.....	21	Parking Brake Adjustment.....	41
Stopping the Rider.....	22	Deck Lift Rod Timing Adjustment.....	41
Zero-Turn Driving Practice.....	22	Deck Leveling Adjustment.....	42
Mowing.....	24	Deck Lift Assist Springs.....	44
Mowing Recommendations.....	24	Long Left Hand Deck Belt Replacement.....	44
Pushing the Rider By Hand.....	26	Short Right Hand Deck Belt Replacement.....	45
Raise and Lower the Roll Bar.....	26	Transmission Drive Belt Replacement.....	46
Attaching a Trailer.....	27	Suspension Adjustment.....	47
Storage.....	27	Battery Maintenance.....	48
<b>Maintenance Schedule</b> .....	<b>28</b>	Battery Service.....	48
<b>Maintenance Procedures</b> .....	<b>29</b>	<b>Troubleshooting</b> .....	<b>50</b>
Service and Maintenance Safety.....	29	Troubleshooting Charts.....	50
Before Maintaining Your Unit.....	29	Troubleshooting Common Cutting Problems.....	51
Checking / Adding Fuel.....	29	<b>Specifications</b> .....	<b>52</b>
Replacing the Fuel Filter.....	29	<b>Warranty</b> .....	<b>53</b>
Check Engine Oil Level.....	30	Warranty Statement.....	53
Briggs & Stratton Vanguard Engines with Remote Oil Tank (Select Models).....	30		
Changing the Engine Oil and Filter (Engines with Remote Oil Tank).....	30		
Changing the Engine Oil and Filter (All Other Models).....	31		
Clean the Engine Compartment Area with Pressurized Air and Water.....	32		
Engine Maintenance.....	32		
Containing Spilled Fluids and Proper Disposal of Waste.....	32		

# General Information

Thank you for purchasing this quality-built Ferris Zero-Turn Riding Mower. We're pleased that you've placed your confidence in the Ferris brand. When operated and maintained according to the manuals, your Ferris product will provide many years of dependable service.

The manuals contain safety information to make you aware of the hazards and risks associated with the unit and how to avoid them. This Zero-Turn Riding Mower was designed to be used as described in operator's manual and operated by trained professionals for finish cutting of established lawns and is not intended for any other purpose. It is important that you read and understand the instructions thoroughly before attempting to start or operate this equipment. **Save these original instructions for future reference.**

The images in this document are representative, and are meant to complement the instructional copy they accompany. Your unit may vary from the images displayed. *LEFT* and *RIGHT* are as seen from the operator's position.

Ferris is a registered trademark of Briggs & Stratton.

## Identifying Your Unit

The following products are covered by this manual:

5901843, 5901845, 5901846, 5901847, 5901875, 5901877, 5901977, 5901978, 5901995, 5901996, 5901923, 5901924, 5901927, 5902025, 5902026, 5902027, 5902028, 5902029 & 5902030

The product identification tag (A, Figure 1) can be found in the location shown.

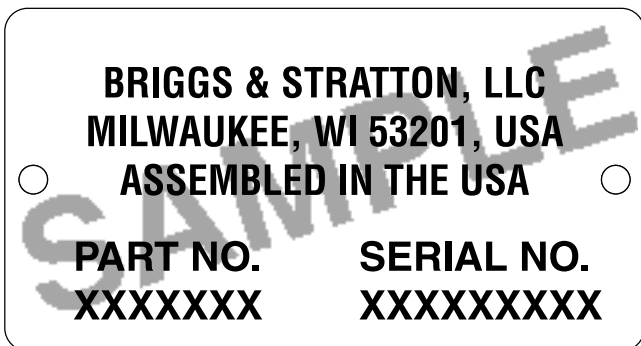
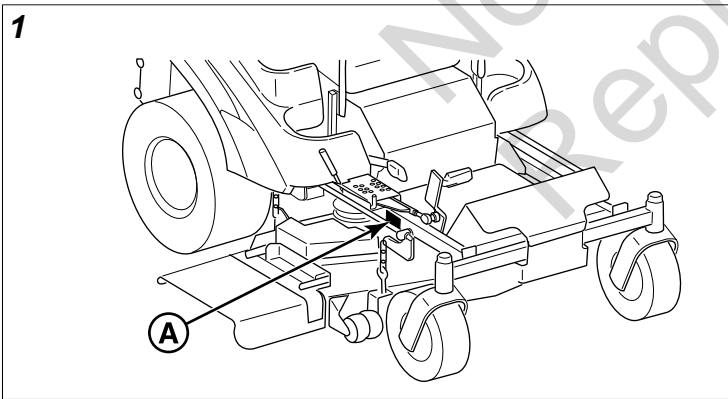

Record your product model number, product serial number, engine model number, and engine serial number in the space provided for easy access.

When contacting your authorized service dealer for replacement parts, service, or information you **MUST** have these numbers.

*Note:* For the location of the engine identification numbers, refer to the engine's operator's manual.

PRODUCT REFERENCE DATA	
Unit Model Number:	
Unit Serial Number:	
Mower Deck Model Number (if applicable):	
Mower Deck Serial Number (if applicable):	
Dealer Name:	
Date Purchased:	
ENGINE REFERENCE DATA	
Engine Make:	
Engine Model:	
Engine Type / Specification:	
Engine Code / Serial Number:	

The Illustrated Parts Lists for this machine can be downloaded from [ferrismowers.com](http://ferrismowers.com). Please provide model and serial number when ordering replacement parts.

## Operator Safety

### Safety Alert Symbol and Signal Words

The safety alert symbol  identifies safety information about hazards that can result in personal injury. A signal word (**DANGER**, **WARNING**, or **CAUTION**) is used with the alert symbol to indicate the likelihood and the potential severity of injury. In addition, a hazard symbol may be used to represent the type of hazard.

 **DANGER** indicates a hazard which, if not avoided, **will** result in death or serious injury.

 **WARNING** indicates a hazard which, if not avoided, **could** result in death or serious injury.

 **CAUTION** indicates a hazard which, if not avoided, **could** result in minor or moderate injury.

**NOTICE** indicates information considered important but not hazard-related.

## California Proposition 65



### WARNING

This product can expose you to chemicals including gasoline engine exhaust, which is known to the State of California to cause cancer and carbon monoxide, which is known to the State of California to cause birth defects or other reproductive harm. For more information go to [www.P65Warnings.ca.gov](http://www.P65Warnings.ca.gov).

## Operating Safely

Read these safety rules and follow them closely. Failure to obey these rules could result in loss of control of unit, severe personal injury or death to you, or bystanders, or damage to property or equipment. **This mowing deck is capable of amputating hands and feet and throwing objects.**

The safety alert triangle () in text signifies important cautions or warnings which must be followed.

## Operating Safety



Congratulations on purchasing a superior-quality piece of lawn and garden equipment. Our products are designed and manufactured to meet or exceed all industry standards for safety.

Do not operate this machine unless you have been trained. Reading and understanding this operator's manual is a way to train yourself.

Power equipment is only as safe as the operator. If it is misused, or not properly maintained, it can be dangerous! Remember, you are responsible for your safety and that of those around you.

Use common sense, and think through what you are doing. If you are not sure that the task you are about to perform can be safely done with the equipment you have chosen, ask a professional: contact your local authorized dealer.

## Read the Manual

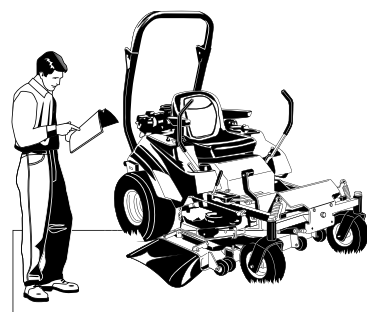

The operator's manual contains important safety information you need to be aware of **BEFORE** you operate your unit as well as **DURING** operation.

Safe operating techniques, an explanation of the product's features and controls, and maintenance information is included to help you get the most out of your equipment investment.

Be sure to completely read the Safety Rules and Information found on the following pages. Also completely read the Operation section.

## Children

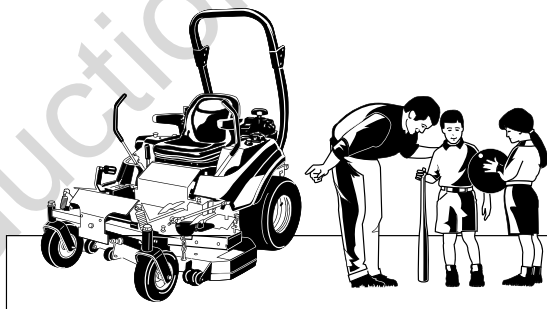

Tragic accidents can occur with children. Do not allow them anywhere near the area of operation. Children are often attracted to the unit and mowing activity. Never assume that children will remain where you last saw them. If there is a risk that children may enter the area where you are mowing, have another responsible adult watch them.

## Slope Operation



Operation on slopes can be dangerous. Using the unit on a slope that is too steep where you do not have adequate wheel traction (and control) can cause sliding, loss of steering, control, and possible rollover. You should not

operate on a slope greater than 15 degrees (a 5.4 foot rise over a 20 foot length).

Avoid turning down slopes; if possible turn up slopes. Avoid sudden turns or rapid speed changes. Reduce speed and use extreme caution on ALL slopes.

Also, note that the surface condition you are on can greatly impact your ability to safely operate this machine. Operating on wet or slippery slopes can cause sliding and loss of steering and control. Do not operate on slopes that are slippery, wet, or have soft soil conditions.

If you feel unsure about operating the unit on a slope, don't do it. It's not worth the risk.

## Thrown Objects

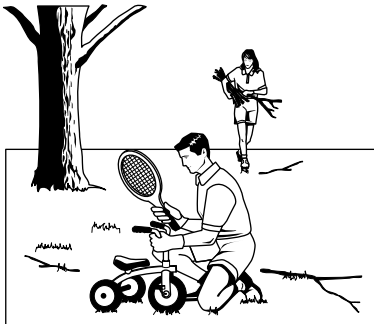

This unit has spinning mower blades. These blades can pick up and throw debris that could seriously injure a bystander. Be sure to clean up the area to be mowed and remove objects that could be thrown by the blade **BEFORE** you start mowing.

Do not operate this unit without the entire grass catcher or discharge guard (deflector) in place.

Also, do not allow anyone in the area while the unit is running! If someone does enter the area, shut the unit off immediately until they leave.

## Moving Parts



This equipment has many moving parts that can injure you or someone else. However, if you stay in the operator zone (stay seated in the seat), and follow the safety rules in this operator's manual, the unit is safe to operate.

The mower deck has spinning mower blades that can amputate hands and feet. Do not allow anyone near the unit while it is running! Keep safety devices (guards, shields, and switches) in place and working.

To help you, the operator, use this equipment safely, it is equipped with an operator-present safety system. Do NOT

attempt to alter or bypass the system. See your dealer immediately if the system does not pass all the safety interlock system tests found in this manual.

## Roll Bar Use



Keep the roll bar in the raised position and fasten the seat belt. There is no roll over protection when the roll bar is down! Do not jump off if the mower tips (it is safer to be secured by the seat belt with the roll bar raised.)

Lower the roll bar only when necessary (such as to temporarily clear a low overhanging obstacle) and **NEVER** remove it. Do **NOT** use the seat belt when the roll bar is down. Raise the roll bar as soon as clearance permits.

## Retaining Walls, Drop-Offs and Water

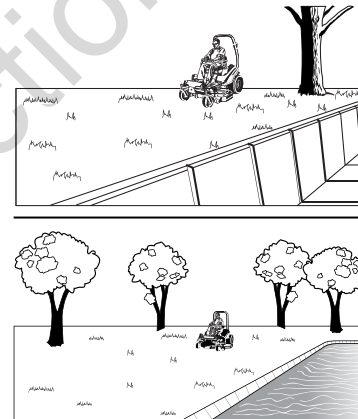

Retaining walls and drop-offs around steps and water are a common hazard. Do **NOT** operate down slope towards or near water, retaining walls, or drop-offs.

Give yourself a minimum of two mower widths of clearance around these hazards and hand-trim with a walk behind mower or string trimmer. Wheels dropping over retaining walls, edges, ditches, embankments, or into water can cause rollovers, which may result in serious injury, death, or drowning.

## Overhead Obstacles

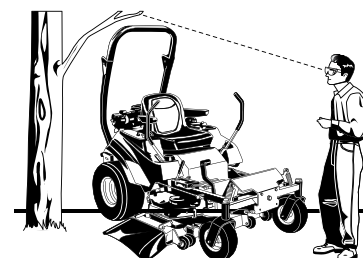

Check for overhead clearances before driving under any objects. Do not allow the roll bar to contact low overhanging obstacles such as tree branches and guide wires.

## Fuel and Maintenance



Always disengage all drives, shutoff the engine, and remove the key before doing any cleaning, refueling, or servicing.

Gasoline and its vapors are extremely flammable. Do not smoke while operating or refueling. Do not add fuel while engine is hot or running. Allow engine to cool for at least 3 minutes prior to adding fuel.

Do not add fuel indoors, in an enclosed trailer, garage, or any other enclosed area that is not well ventilated. Gasoline spills should be cleaned up promptly and before operation begins.

Gasoline should be stored only in sealed containers approved for fuel.

Proper maintenance is critical to the safety and performance of your unit. Keep the unit free of grass, leaves, and excess oil. Be sure to perform the maintenance procedures listed in this manual, especially periodically testing the safety system.

## Enclosed Areas

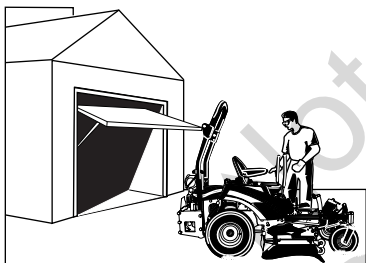

Only operate this unit outdoors and away from unventilated areas such as inside garages or enclosed trailers. The engine emits poisonous carbon monoxide gas and prolonged exposure in an enclosed area can result in serious injury or death.

## Slope Identification Guide

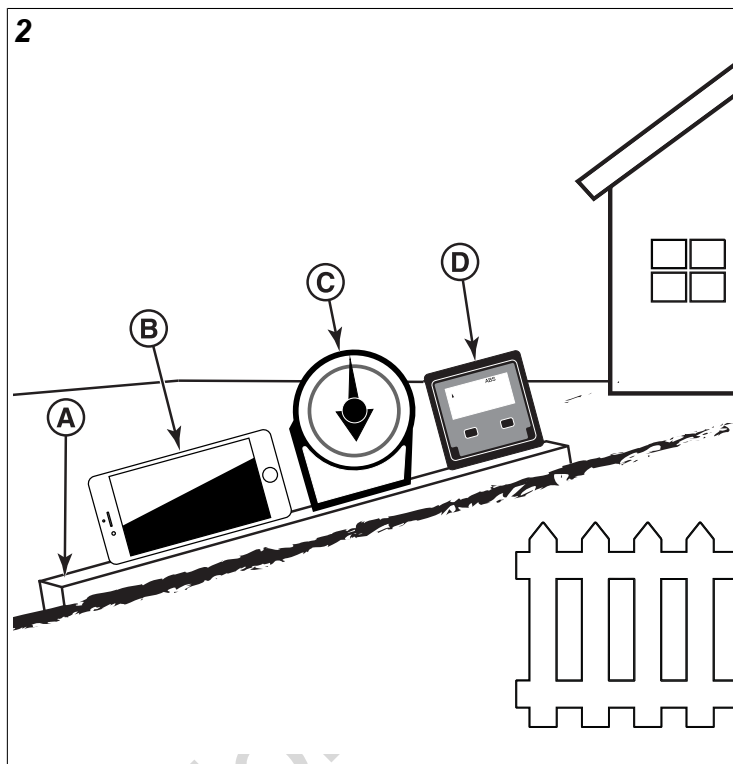

**How to measure the slope of a lawn surface with a smartphone or an angle finder tool:**

### **WARNING**

Do not operate on slopes greater than 15 degrees.

1. Use a straight edge at least two (2) feet long (A, Figure 2). A 2x4 or a straight piece of metal works well.
2. Angle finder tools.
  - a. **Use your smartphone:** Many smartphones (B, Figure 2) have an inclinometer (angle finder) located under the compass application (app). Or, search an app store for an Inclinometer app.
  - b. **Use angle finder tools:** Angle finder tools (C and D, Figure 2) are available at local hardware stores or online (also called inclinometer, protractor, angle meter, or angle gauge). Dial type (C) or digital type (D) work, others may not. Read and obey the user instructions supplied with the angle finder tool.
3. Put the two (2) feet long straight edge along the steepest part of the lawn slope. Put the board up and down the slope.
4. Lay the smartphone or angle finder tool on the straight edge and read the angle in degrees. This is the slope of your lawn.

*Note:* A paper gauge slope identification guide is included in your product literature packet and is also available to download from the manufacturer's website.

## Safety Rules and Information

## Training

- Read, understand, and follow all instructions in the manual and on the unit before starting. If the operator(s) or mechanic(s) can not read English it is the owner's responsibility to explain this material to them.
- Become familiar with the safe operation of the equipment, operator controls, and safety signs.
- All operators and mechanics should be trained. The owner is responsible for training the users.
- Only allow responsible adults, who are familiar with the instructions, to operate the unit.
- Never let children or untrained people operate or service the equipment. Local regulations may restrict the age of the operator.
- The owner/user can prevent and is responsible for accidents or injuries occurring to themselves, other people or property.
- Data indicates that operators, age 60 years and above, are involved in a large percentage of riding mower-related injuries. These operators should evaluate their ability to operate the riding mower safely enough to protect themselves and others from serious injury.

## Preparation

- Evaluate the terrain to determine what accessories and attachments are needed to properly and safely perform the job. Use only accessories and attachments approved by the manufacturer.
- Wear appropriate clothing including safety shoes, safety glasses and ear protection. Long hair, loose clothing or jewelry may get tangled in moving parts.
- Inspect the area where the equipment is to be used and remove all objects such as rocks, toys and wire, which can be thrown by the machine.
- Use extra care when handling gasoline and other fuels. They are flammable and vapors are explosive.
- Use only an approved container.
- Never remove fuel cap or add fuel with the engine running. Allow engine to cool before refueling. Do not smoke.
- Never refuel or drain the machine indoors.
- Check that operator's presence controls, safety switches and shields are attached and functioning properly. Do not operate unless they are functioning properly.

## Operation

- Never run an engine in an enclosed area.
- Mow only in the daylight or with good artificial light, keeping away from holes and hidden hazards.
- Be sure all drives are in neutral and parking brake is engaged before starting engine. Only start engine from the operator's position. Use seat belts if provided.
- Be sure of your footing while using pedestrian controlled equipment, especially when backing up. Walk, don't run. Reduced footing could cause slipping.
- Slow down and use extra care on hillsides. Be sure to travel in the recommended direction on hillsides. Turf

conditions can affect the machines stability. Use caution when operating near drop-offs.

- Do not mow in reverse unless absolutely necessary. Always look down, behind and to the side before changing directions.
- Be aware of the mower discharge direction and do not point it at anyone. Do not operate the mower without either the entire grass catcher or the deflector in place.
- Slow down and use caution when making turns and when changing directions on slopes.
- Never raise deck with the blades running.
- Never leave a running unit unattended. Always disengage the PTO, set parking brake, stop engine, and remove keys before dismounting. Keep hands and feet away from the cutting units.
- Turn off the PTO switch to disengage the blades when not mowing.
- Never operate with guards not securely in place. Be sure all interlocks are attached, adjusted properly and functioning properly.
- Never operate with the discharge deflector raised, removed or altered, unless using a grass catcher.
- Do not change the engine governor setting or overspeed the engine.
- Stop on level ground, lower implements, disengage drives, engage parking brake, shut off engine before leaving the operator's position for any reason including emptying the grass catchers or unclogging the chute.
- Stop equipment and inspect blades after striking objects or abnormal vibration occurs. Make necessary repairs before resuming operations.
- Keep hands and feet away from the cutting units.
- Never carry passengers and keep pets and bystanders away.
- Do not operate the unit while under the influence of alcohol or drugs.
- Slow down and use caution when making turns and crossing roads and sidewalks. Stop blades if not mowing.
- Use care when loading or unloading the machine into a trailer or truck.
- Use care when approaching blind corners, shrubs, trees or other objects that may obscure vision.
- To reduce fire hazard, keep unit free of grass, leaves & excess oil. Do not stop or park over dry leaves, grass or combustible materials.



### WARNING

It is a violation of California Public Resource Code, Section 4442, to use or operate the engine on any forest-covered, brush-covered or grass-covered land unless the exhaust system is equipped with a spark arrester, as defined in Section 4442, maintained in effective working order. Other states or federal jurisdictions may have similar laws. Contact an Authorized Service Dealer to obtain a spark arrester designed for the exhaust system installed on this engine.

- OSHA regulations may require the use of hearing protection when exposed to sound levels greater than 85 dBA for an 8 hour time period.



This machine produces sound levels in excess of 85 dBA at the operator's ear and can cause hearing loss through extended periods of exposure.

Wear hearing protection when operating this machine.

## Slope Operation

Slopes are a major factor related to loss-of-control and tip-over accidents, which can result in severe injury or death. All slopes require extra caution. If you cannot back up the slope or if you feel uneasy on it, do not drive on it.



Do not use this machine on slopes greater than 15°.\*

Select slow ground speed before driving onto slope. Use extra caution when operating on slopes with rear-mounted grass catchers.

Avoid turning down slopes; if possible turn up slopes. Use caution when changing direction and **DO NOT START OR STOP ON SLOPE.**

\* This limit was determined per International Standard ISO 5395-3:2013, Section 4.6 and is based on the ISO 5395-3 Stability Test procedure described in Annex A. The 15 degree "limit of stability" is equal to 60% of the angle at which machine lift-off occurred in static tests. Actual dynamic stability may vary depending on operating conditions.

### Do:

- Remove obstacles such as rocks, tree limbs, etc.
- Watch for holes, ruts, or bumps. Uneven terrain could overturn the unit. Tall grass can hide obstacles.
- Use slow speed. Choose a slow speed so that you will not have to stop or change speed while on the slope.
- Use extra care with grass catchers or other attachments. These can change the stability of the unit.
- Keep all movement on the slopes slow and gradual. Do not make sudden changes in speed or direction.
- See your authorized dealer for recommendations of available weights to improve stability.

### Do NOT:

- Avoid starting, stopping, or turning on a slope. Do NOT make sudden changes in speed or direction, which could cause the mower to rollover.
- Do not mow down slope towards or near drop-offs, ditches, or embankments. The mower could suddenly turn over if a wheel is over the edge of a cliff or ditch, or if an edge caves in. Give yourself a minimum of two mower widths of clearance around these hazards.
- Do not mow on wet grass. Reduced footing or traction could cause sliding.
- Do not try to stabilize the unit by putting your foot on the ground. (ride-on units).
- Do not mow excessively steep slopes.

- Do not use grass catcher on steep slopes.
- Do not mow slopes if you cannot back up them.

## Towed Equipment (Ride-On Units)

- Tow only with a machine that has a hitch designed for towing. Do not attach towed equipment except at the hitch point.
- Follow the manufacturer's recommendations for weight limit for towed equipment and towing on slopes. See attaching a trailer under OPERATION.
- Never allow children or others in or on towed equipment.
- On slopes, the weight of the towed equipment may cause loss of traction and loss of control.
- Travel slowly and allow extra distance to stop.
- Do not shift to neutral and coast down hill.

## Children

Tragic accidents can occur if the operator is not alert to the presence of children. Children are often attracted to the unit and the mowing activity. Never assume that children will remain where you last saw them.

- Keep children out of the mowing area and under the watchful care of another responsible adult.
- Be alert and turn unit off if children enter the area.
- Before and during reverse operation, look behind and down for small children.
- Never carry children, even with the blade(s) off. They may fall off and be seriously injured or interfere with safe unit operation. Children who have been given rides in the past may suddenly appear in the mowing area for another ride and be run over or backed over by the machine.
- Never allow children to operate the unit.
- Use extra care when approaching blind corners, shrubs, trees, or other objects that may obscure vision.

## Emissions

- Engine exhaust from this product contains chemicals known, in certain quantities, to cause cancer, birth defects, or other reproductive harm.
- Look for the relevant Emissions Durability Period and Air Index information on the engine emissions label.

## Service and Maintenance

To avoid personal injury or property damage, use extreme care in handling gasoline. Gasoline is extremely flammable and the vapors are explosive.

### Safe Handling of Gasoline

- Extinguish all cigarettes, cigars, pipes, and other sources of ignition.
- Use only approved gasoline containers.
- Never remove the gas cap or add fuel with the engine running. Allow the engine to cool before refueling.
- Never fuel the machine indoors.
- Never store the machine or fuel container where there is an open flame, spark, or pilot light such as near a water heater or other appliance.



- Never fill containers inside a vehicle or on a truck bed with a plastic bed liner. Always place containers on the ground away from your vehicle before filling.
- Remove gas-powered equipment from the truck or trailer and refuel it on the ground. If this is not possible, then refuel such equipment on a trailer with a portable container, rather than from a gasoline dispenser nozzle.
- Keep nozzle in contact with the rim of the fuel tank or container opening at all times until fueling is complete. Do not use a nozzle lock-open device.
- If fuel is spilled on clothing, change clothing immediately.
- Never over-fill the fuel tank. Replace gas cap and tighten securely.
- Use extra care in handling gasoline and other fuels. They are flammable and vapors are explosive.
- If fuel is spilled, do not attempt to start the engine but move the machine away from the area of spillage and avoid creating any source of ignition until fuel vapors have dissipated.
- Replace all fuel tank caps and fuel container caps securely.

### Maintenance and Storage

- Always observe safe refueling and fuel handling practices when refueling the unit after transportation or storage.
- Always follow the engine manual instructions for storage preparations before storing the unit for both short and long term periods.
- Always follow the engine manual instructions for proper start-up procedures when returning the unit to service.
- Never store the machine or fuel container inside where there is an open flame, such as in a water heater. Allow unit to cool before storing.
- Shut off fuel while storing or transporting. Do not store fuel near flames or drain indoors.
- Keep all hardware, especially blade attachment bolts, tight and keep all parts in good working condition. Replace all worn or damaged decals.
- Never tamper with safety devices. Check their proper operation regularly.
- Disengage drives, lower implement, set parking brake, stop engine and remove key or disconnect spark plug wire. Wait for all movement to stop before adjusting, cleaning or repairing.
- Clean grass and debris from cutting units, drives, mufflers, and engine to prevent fires. Clean up oil or fuel spillage.
- Let engine cool before storing and do not store near flame.
- Stop and inspect the equipment if you strike an object. Repair, if necessary, before restarting.
- Park machine on level ground. Never allow untrained personnel to service machine.
- Use jack stands to support components when required.
- Carefully release pressure from components with stored energy.
- Disconnect battery or remove spark plug wire before making any repairs. Disconnect the negative terminal

first and the positive last. Reconnect positive first and negative last.

- Use care when checking blades. Wrap the blade(s) or wear gloves, and use caution when servicing them. Only replace blades. Never straighten or weld them.
- Keep hands and feet away from moving parts. If possible, do not make adjustments with the engine running.
- Charge batteries in an open well ventilated area, away from spark and flames. Unplug charger before connecting or disconnecting from battery. Wear protective clothes and use insulated tools.
- Grass catcher components are subject to wear, damage, and deterioration, which could expose moving parts or allow objects to be thrown. Frequently check components and replace with manufacturer's recommended parts, when necessary.
- Check brake operation frequently. Adjust and service as required.
- Use only factory authorized replacement parts when making repairs.
- Always comply with factory specifications on all settings and adjustments.
- Only authorized service locations should be utilized for major service and repair requirements.
- Never attempt to make major repairs on this unit unless you have been properly trained. Improper service procedures can result in hazardous operation, equipment damage and voiding of manufacturer's warranty.



### WARNING

**Units with hydraulic pumps, hoses, or motors:** Hydraulic fluid escaping under pressure may have sufficient force to penetrate skin and cause serious injury. If foreign fluid is injected into the skin it must be surgically removed within a few hours by a doctor familiar with this form of injury or gangrene may result. Keep body and hands away from pin holes or nozzles that eject hydraulic fluid under high pressure. Use paper or cardboard, and not hands, to search for leaks. Make sure all hydraulic fluid connections are tight and all hydraulic hoses and lines are in good condition before applying pressure to the system. If leaks occur, have the unit serviced immediately by your authorized dealer.



### WARNING

Stored energy device. Improper release of springs can result in serious personal injury. Springs should be removed by an authorized technician.



### WARNING

**Units equipped with an engine radiator:** Stored energy device. To prevent serious bodily injury from hot coolant or steam blow-out, never attempt to remove the radiator cap while the engine is running. Stop the engine and wait until it is cool. Even then, use extreme care when removing the cap.

## Roll Bar Instructions

For models equipped with factory-installed Roll Over Protection System (ROPS).



### WARNING

In order to avoid serious injury or death from roll over, it is important to follow the warnings listed below.

### Operational Warnings

- Always use the seat belt when the roll bar is in the raised position.
- Never use the seat belt when the roll bar is in the down position.
- Remember there is no roll over protection when the roll bar is in the down position so it is very important to always keep the roll bar in the raised position whenever possible.
- Lower the roll bar to the down position only when it is absolutely necessary.
- Check for overhead clearances before driving under any objects. Do not allow roll bar to contact low overhanging obstacles such as tree branches and guide wires.
- Never remove the roll bar from the vehicle.
- Do not exceed the machine weight rating of the roll bar.
- Read and follow all of the instructions shown below regarding the inspection and maintenance of the roll bar structure and the seat belt.

### Inspection of the Roll Bar Protective Structure



### WARNING

Failure to properly inspect and maintain the ROLL BAR protective structure can cause serious injury or death.

A ROLL BAR, like any other safety device, needs to be periodically inspected to verify that the integrity of the device has not been compromised through normal machine use, misuse, age degradation, modifications, or a roll over.

To maintain operator roll over protection and roll bar effectiveness:

- If a ROLL BAR becomes damaged for any reason, such as a collision, roll over or impact, the ROLL BAR must be replaced. Small undetectable cracks can reduce the effectiveness of the ROLL BAR. Never weld, straighten, or repair the ROLL BAR.
- Never alter the ROLL BAR by welding anything to it or by drilling additional holes.
- BEFORE FIRST TIME USE - Inspect the ROLL BAR structure and mounting hardware for:
  - 1) Check to make sure the machine GVW (Gross Vehicle Weight), including attachments, restrained payload, fuel and operator, is not in excess of the maximum weight specified on the ROLL BAR label.
  - 2) Make sure there isn't any missing, damaged, or loose mounting hardware.
  - 3) Make sure the ROLL BAR has been correctly and completely installed.

- EVERY 100 HOURS - Inspect the ROLL BAR structure and mounting hardware for:
  - 1) Any cracks in the structure (structural members and/or welds).
  - 2) Significant corrosion on any part of the ROLL BAR structure or hardware.
  - 3) Missing, damaged, or loose mounting hardware
  - 4) Mounting hardware that is of a grade lesser than specified.
  - 5) Machine GVW (Gross Vehicle Weight), including attachments, restrained payload, fuel and operator, in excess of the maximum weight specified on the ROLL BAR label.
  - 6) Any modifications that have been made, such as unauthorized welds and holes.
  - 7) Any permanent deformation or twisting of the ROLL BAR structure.
  - 8) That the ROLL BAR label is still in place and is readable.
  - 9) That the ROLL BAR on-product warning labels are still on the ROLL BAR and are readable.
- If there is any doubt as to the condition of the ROLL BAR, remove the machine from service and contact your dealer for assistance.

### Inspection and Maintenance of the Roll Bar Seat Belt



### WARNING

Failure to properly inspect and maintain the seat belt can cause serious injury or death.

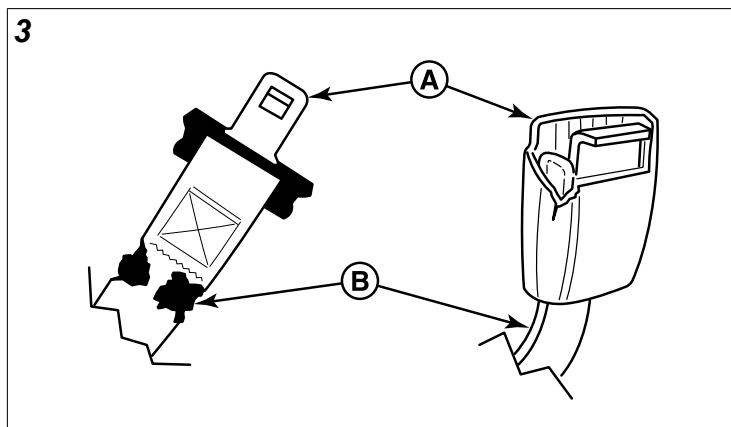

- The seat belt like the ROLL BAR, needs to be periodically inspected to verify that the integrity has not been compromised through normal machine use, misuse, age degradation, modifications, or a roll over. If the seat belt does not pass all of the following tests, it should be replaced.
- BEFORE EACH USE – Conduct the following inspections/maintenance of the seat belt and retraction mechanism:

- 1) Check for dirt or debris in the retraction mechanism. If dirt or debris is found, it should be removed.
- 2) Check to make sure the retraction mechanism retracts easily and completely.
- 3) Check for damage to any part of the seat belt (A, Figure 3) such as nicks, cuts, loose stitching, or fraying.
- 4) Check that the buckle and latch (B) operate properly and that the latch plate is not excessively worn, deformed, or the buckle is damaged or cracked. The seat belt should latch and release easily.

## Safety Decals and Icons

Read the safety decals before operating your unit. The cautions and warnings are for your safety. Understand and follow all safety decals to avoid a personal injury or damage to the unit.



### WARNING

If any safety decals become worn or damaged and cannot be read, order replacement decals from your local dealer.

#### North American Models:

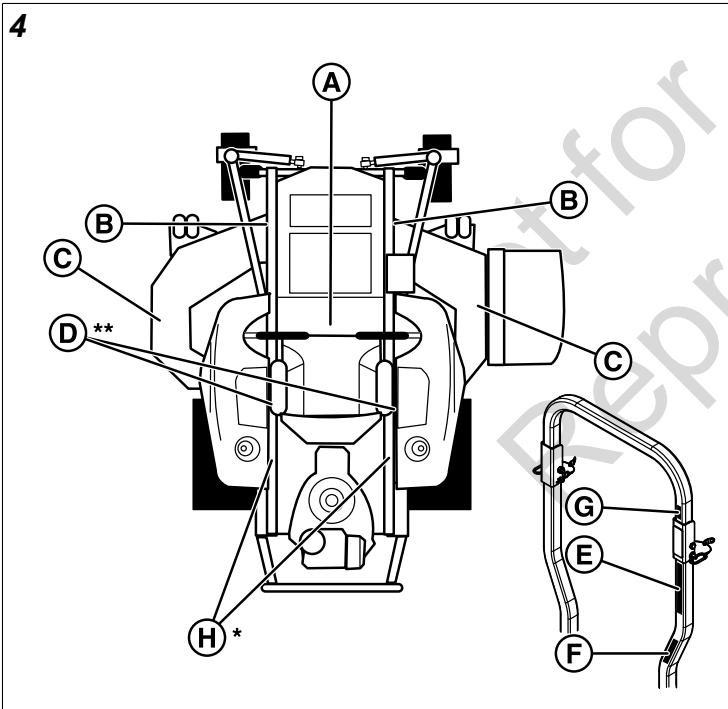

- \* Located on the front of the Roll Bar pockets on the frame of the unit.
- \*\* Located near the transmission fans.

- A. Part Number: 5109104 - Decal, Main Safety
- B. Part Number: 5061245 - Decal, Pinch Point
- C. Part Number: 7101665 - Decal, Danger
- D. Part Number: 5103184 - Decal Warning
- E. Part Number: 5104082 - Decal, Warning, Folding Roll Bar
- F. Part Number: 5104083 - Decal, Caution, Folding Roll Bar

- G. Part Number: 5100405 - Decal, Warning Roll Bar
- H. Part Number: 5100683 - Decal, Warning Roll Bar Removed

#### Export Models:

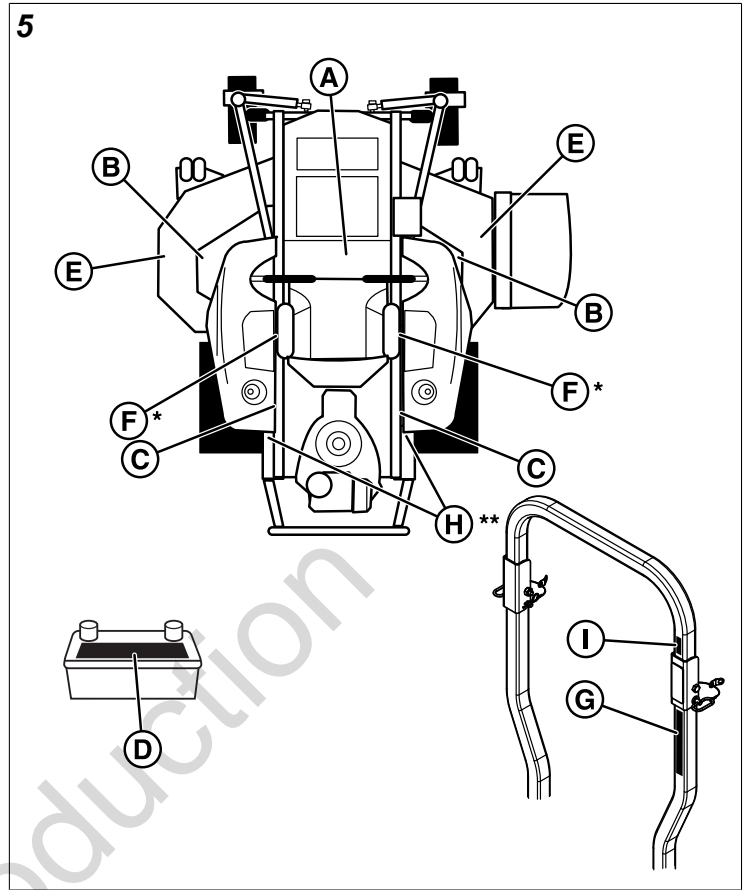







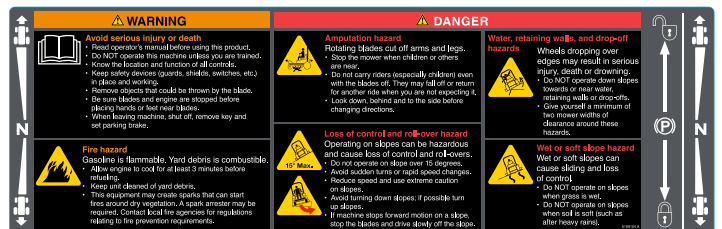



- \* Decal is located on the seat support rail above the transmissions.
- \*\* Decals are located on the front of the Roll Bar pockets on the frame of the unit.

- A. Part Number: 5106565 - Decal, Main Safety
- B. Part Number: 5061246 - Decal, Pinch Point
- C. Part Number: 5102456 - Decal, Fire
- D. Battery Safety Decal
- E. Part Number: 7106109 - Decal, Danger
- F. Part Number: 5061042 - Decal, Danger
- G. Part Number: 5100536 - Decal, Safety, Roll Bar
- H. Part Number: 5100685 - Decal, Warning, Roll Bar
- I. Part Number: 5100537 - Decal, Safety Overhead Obstacles

## 5109104 - Decal, Main Safety





	<b>Safety alert triangle.</b>
 <b>WARNING</b>	
	<p><b>Avoid serious injury or death.</b></p> <ul style="list-style-type: none"> <li>• Read operator's manual before using this product.</li> <li>• Do NOT operate this machine unless you are trained.</li> <li>• Know the location and function of all controls.</li> <li>• Keep safety devices (guards, shields, switches, etc.) in place and working.</li> <li>• Remove objects that could be thrown by the blade.</li> <li>• Be sure blades and engine are stopped before placing hands or feet near blades.</li> <li>• When leaving machine, shut off, remove key and set parking brake.</li> </ul>
	<p><b>Fire hazard.</b> Gasoline is flammable. Yard debris is combustible.</p> <ul style="list-style-type: none"> <li>• Allow engine to cool for at least 3 minutes before refueling.</li> <li>• Keep unit cleaned of yard debris.</li> <li>• This equipment may create sparks that can start fires around dry vegetation. A spark arrester may be required. Contact local fire agencies for regulations relating to fire prevention requirements.</li> </ul>
 <b>DANGER</b>	
	<p><b>Amputation hazard.</b> Rotating blades cut off arms and legs.</p> <ul style="list-style-type: none"> <li>• Stop the mower when children or others are near.</li> <li>• Do not carry riders (especially children) even with the blades off. They may fall off or return for another ride when you are not expecting it.</li> <li>• Look down, behind and to the side before changing directions.</li> </ul>

	<p><b>Loss of control and roll-over hazard.</b> Operating on slopes can be hazardous and cause loss of control and roll-overs.</p> <ul style="list-style-type: none"> <li>• Do not operate on slope over 15 degrees.</li> <li>• Avoid sudden turns or rapid speed changes.</li> <li>• Reduce speed and use extreme caution on slopes.</li> <li>• Avoid turning down slopes; if possible turn up slopes.</li> <li>• If machine stops forward motion on a slope, stop the blades and drive slowly off the slope.</li> </ul>
	
	<p><b>Water, retaining walls, and drop-off hazards.</b> Wheels dropping over edges may result in serious injury, death or drowning.</p> <ul style="list-style-type: none"> <li>• Do NOT operate down slopes towards or near water, retaining walls or drop-offs.</li> <li>• Give yourself a minimum of two mower widths of clearance around these hazards.</li> </ul>
	<p><b>Wet or soft slope hazard.</b> Wet or soft slopes can cause sliding and loss of control.</p> <ul style="list-style-type: none"> <li>• Do NOT operate on slopes when grass is wet.</li> <li>• Do NOT operate on slopes when soil is soft (such as after heavy rains).</li> </ul>

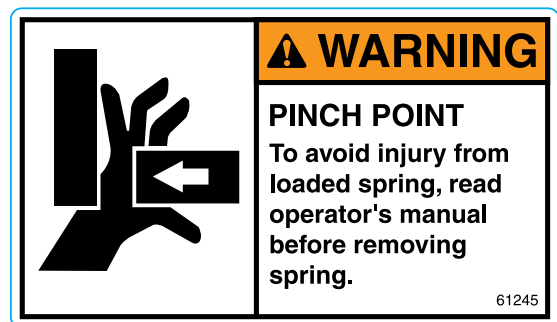



**5061245 - Decal, Pinch Point**



	<b>Safety alert triangle.</b>
 <b>WARNING</b>	
	<p><b>Pinch Point.</b> To avoid injury from loaded spring, read operator's manual before removing spring.</p>



# 7101665 - Decal, Danger, Discharge

<b>⚠ DANGER</b>	
<b>Amputation and thrown objects hazard</b>	
 <ul style="list-style-type: none"> <li>• Keep hands and feet away from deck.</li> <li>• Do not operate mower unless discharge chute or entire grass catcher is in its proper place.</li> </ul>	
7101665	

	<b>Safety alert triangle.</b>
 <b>DANGER</b>	
 	Keep hands and feet away from deck.
	Do not operate mower unless discharge chute or entire grass catcher is in its proper place.



## 5103184 - Decal, Warning, Hand in Belt

<b>⚠ WARNING</b>	
<p><b>Amputation and Pinch Point Hazard</b> To avoid injury from rotating parts, stay clear of parts and keep all shields and guards in place.</p>	
5103184	





	<b>Safety alert triangle.</b>
 <b>WARNING</b>	
	<b>Amputation and Pinch Point Hazard.</b> To avoid injury from rotating parts, stay clear of parts and keep all shields and guards in place.

## Folding Roll Bar Decals





<b>5104082 - Decal, Warning, Folding Roll Bar</b>	<b>5100405 - Decal, Warning, ROPS</b>
---	---------------------------------------

<div style="border: 1px solid black; padding: 5px;"> <p style="background-color: orange; color: black; text-align: center; margin: 0;"><b>⚠ WARNING</b></p>  <p><b>AVOID SERIOUS INJURY OR DEATH FROM ROLL OVER:</b> Keep roll bar in the raised position and use seat belt. <b>THERE IS NO ROLL OVER PROTECTION WHEN THE ROLL BAR IS DOWN.</b> Lower the roll bar only when necessary and NEVER remove it. Do NOT use seat belt when the roll bar is down. Raise the roll bar as soon as clearance permits. Do NOT jump off if mower tips. Read and follow all operating instructions and warnings in the operator's manual.</p> </div>	<div style="border: 1px solid black; padding: 5px;"> <p style="background-color: orange; color: black; text-align: center; margin: 0;"><b>⚠ WARNING</b></p>  <p><b>LOW OVERHANGING OBJECTS HAZARD</b> Check for contact between the discharge chute and the mower deck as the mower is in gear.</p> </div>
--	---

<b>5104083 - Decal, Caution, Folding Roll Bar</b>	<b>5100683 - Decal, Warning, ROPS Removed</b>
<div style="border: 1px solid black; padding: 5px;"> <p style="background-color: orange; color: black; text-align: center; margin: 0;"><b>⚠ CAUTION</b></p> <p><b>ROLL OVER PROTECTIVE STRUCTURE</b> To maintain operator protection and roll bar certification: Replace a damaged roll bar; do NOT attempt to repair or modify. Any alteration of the roll bar must be approved by the manufacturer. DO NOT exceed the machine weight rating of the roll bar.</p> </div>	<div style="border: 1px solid black; padding: 5px;"> <p style="background-color: orange; color: black; text-align: center; margin: 0;"><b>⚠ WARNING</b></p> <p>Avoid serious injury or death from roll over. Do not operate without the roll bar installed on operator.</p>  </div>





	<b>Safety alert triangle.</b>
 <b>WARNING</b>	
	<p><b>Avoid serious injury or death from roll over.</b></p> <ul style="list-style-type: none"> <li>• Keep roll bar in the raised position and use seat belt.</li> <li>• There is no roll over protection when the roll bar is down.</li> <li>• Lower the roll bar only when necessary and never remove it.</li> <li>• Do not use seat belt when the roll bar is down.</li> <li>• Raise the roll bar as soon as clearance permits.</li> <li>• Do not jump off if mower tips.</li> <li>• Read and follow all operating instructions and warnings in the operator's manual.</li> </ul>
 <b>CAUTION</b>	



N/A	<p><b>Roll Over Protective Structure.</b> To maintain operator protection and roll bar certification:</p> <ul style="list-style-type: none"> <li>• Replace a damaged roll bar, do not attempt to repair or modify.</li> <li>• Any alteration of the roll bar must be approved by the manufacturer.</li> <li>• Do not exceed the machine weight rating of the roll bar.</li> </ul>
-----	---

 <b>WARNING</b>	
	<p><b>Low overhanging obstacles hazard.</b></p> <ul style="list-style-type: none"> <li>• Check for overhead clearances before driving under any objects. Do not allow roll bar to contact low overhanging obstacles, such as tree branches and guide wires.</li> </ul>
 <b>WARNING</b>	
	<p><b>Avoid serious injury or death from rollover.</b></p> <ul style="list-style-type: none"> <li>• Do not operate without the rollbar installed and operational.</li> </ul>

### 5106565 - Decal, Main Safety



	<p><b>Warning:</b> Read and understand the Operator's Manual before using this unit. Know the location and function of all controls. Do not operate this machine unless you are trained.</p>
	<p><b>Warning:</b> Consult technical literature before performing technical repairs or maintenance. When leaving the machine, shutoff engine, set the parking brake to the lock position, and remove the ignition key.</p>
	<p><b>Danger - Amputation and dismemberment hazard:</b> To avoid injury from rotating blades and moving parts, keep safety devices (guards, shields and switches) in place and working.</p>
	<p><b>Danger - Loss of traction, sliding, steering and control on slopes hazard:</b> If machine stops forward motion, stop the blades, and drive slowly off the slope.</p>
	<p><b>Danger - Amputation hazard:</b> Do not mow when children or others are around. Never carry riders especially children even with the blades off. Do not mow in reverse unless absolutely necessary. Look down and behind – before and while backing.</p>

	<p><b>Danger - Tipping and slipping hazard:</b> Operating on slopes can be hazardous and cause a loss of control and roll-overs. Do not operate on slopes over 15* degrees. Avoid sudden turns or rapid speed changes. Reduce speed and use extreme caution on slopes. Avoid turning down slopes; if possible, turn up slopes. Do not operate down slopes towards or near water, retaining walls, or drop-offs. Give yourself a minimum of two mower widths of clearance around these hazards.</p>
	<p><b>Danger - Thrown objects hazard:</b> Keep bystanders and children a safe distance away. Remove objects that can be thrown by the blade. Do not mow without discharge chute in place.</p>

\*This limit was determined per International Standard ISO 5395-3:2013, Section 4.6 and is based on the ISO 5395-3 Stability Test procedure described in Annex A. The 15 degree "limit of stability" is equal to 60% of the angle at which machine lift-off occurred in static tests. Actual dynamic stability may vary depending on operating conditions.

### 5061246 - Decal, Pinch Point



	<p><b>Danger: Dismemberment</b> - This machine can crush and cut. Keep hands away from deck lift rod.</p>
---	---

### 5102456 - Decal, Fire



	<p><b>Danger: Fire Hazard:</b> Keep unit free of grass, leaves and excess oil. Do not add fuel while engine is hot or running. Stop engine, remove key and allow to cool for at least 3 minutes prior to adding fuel. Do not add fuel indoors, in an enclosed trailer, garage or other enclosed areas. Clean up spilled fuel. Do not smoke while operating this machine.</p>
---	--

## Battery Safety Decal

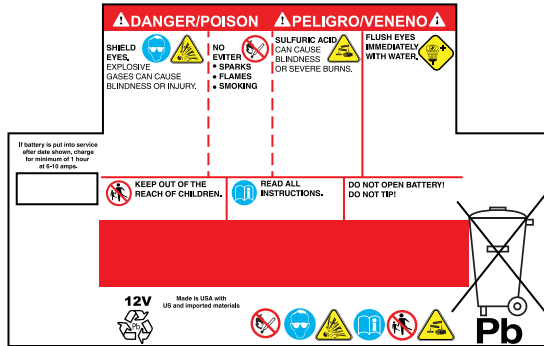

	<p><b>Danger - Amputation and Thrown Objects Hazard:</b> To avoid injury from rotating blades, stay clear of deck edge and keep others away.</p>
--	--

## 5061042 - Decal, Danger

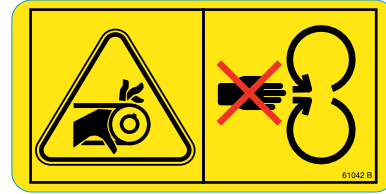

	<p><b>Danger: Dismemberment:</b> This machine can crush and cut. Keep hands away from belts and pulleys.</p>
--	--

	<p><b>Warning: Fire Hazard -</b> Keep children, open flames and sparks away from the battery, which could ignite explosive gases.</p>
	<p><b>Warning: Sulfuric acid can cause blindness or severe burns -</b> Always wear safety goggles or a face shield when working on or near a battery.</p>
	<p><b>Warning: Batteries produce explosive gases -</b> Read and understand the Operator's Manual before using this machine.</p>
	<p><b>Important: Do not discard a battery in the trash -</b> Contact local authorities for disposal and/or recycling of batteries.</p>
	<p><b>Flush eyes immediately with water. Get medical help fast.</b></p>

## 7106109 - Decal, Danger, Discharge



	<p><b>Danger - Thrown Objects Hazard:</b> Do not mow without discharge chute or entire grass catcher in place.</p>
--	--

## Roll Bar Decals

<p><b>5100536 - Decal, Safety, Roll Bar</b></p>	<p><b>5100537 - Decal, Safety, Overhead Obstacles</b></p>
	<p><b>5100685 - Decal, Warning, Roll Bar</b></p>

	<p><b>Warning: Avoid Serious Injury or Death from Roll Over -</b> Keep roll bar in the raised position and use seat belt. There is no roll over protection when roll bar is down. Lower roll bar only when necessary and NEVER remove it. Raise the roll bar as soon as clearance permits.</p>
--	--

	<p><b>Warning: Avoid Serious Injury or Death from Roll Over -</b> Keep roll bar in the raised position and use seat belt. Do NOT use seat belt when the roll bar is down.</p>
--	---

	<p><b>Warning: Avoid Serious Injury or Death from Roll Over -</b> Do NOT jump off if the mower tips. Read and follow all operating instructions and warnings in the operator's manual.</p>
--	--



**Warning: Low Overhanging Obstacles Hazard** - Check for overhead clearances before driving under any objects. Stay clear. Do NOT allow roll bar to contact low overhanging obstacles, such as tree branches and guide wires. Read and follow all operating instructions and warnings in the operator's manual.

## Safety Icons for Optional Jack Kit Accessory

An optional jack kit is available as an accessory through your normal parts source. Please see the explanations below for the safety icons displayed on the jack kit.



**Part Number:** 5105632 - Decal, Warnings, Svc Jack

### 1.) Warning - Read the Operator's Manual.

**2.) Crushing Hazard, Mower:** (1.) Park machine on flat level ground and engage the parking brake; (2.) Stop the engine and remove the ignition key; (3.) Properly jack the machine and secure with jack stands before working under the machine.

## Safety Interlock System

This unit is equipped with safety interlock switches. These safety systems are present for your safety, do not attempt to bypass safety switches, and never tamper with safety devices. Check their operation regularly.

### Operational SAFETY Checks

#### Test 1 - Engine SHOULD NOT crank if:

- PTO switch is engaged, OR
- Parking brake is not engaged.

#### Test 2 - Engine SHOULD crank if:

- PTO switch is not engaged, AND
- Parking brake is engaged.

#### Test 3 - Engine should SHUT OFF if:

- Operator rises off seat with PTO engaged, OR
- Operator rises off seat with parking brake disengaged.

#### Test 4 - Blade Brake Check

Mower blades and mower drive belt should come to a complete stop within seven (7) seconds after electric PTO switch is turned off (or operator rises off seat). If mower drive belt does not stop within seven (7) seconds, see your dealer.

*NOTE: Once the engine has stopped, PTO switch must be turned off, parking brake must be engaged, and the ground speed control levers must be locked in the NEUTRAL position*

after the operator returns to the seat in order to start the engine.



### WARNING

If the unit does not pass a safety test, do not operate it. See your authorized dealer. Under no circumstance should you attempt to defeat the purpose of safety interlock system.

## Features and Controls

### Control Functions and Locations

The information below briefly describes the function of individual controls. Starting, stopping, driving, and mowing require the combined use of several controls applied in specific sequences. To learn what combination and sequence of controls to use for various tasks see the *Operation* section.

### Zero-Turn Rider Controls

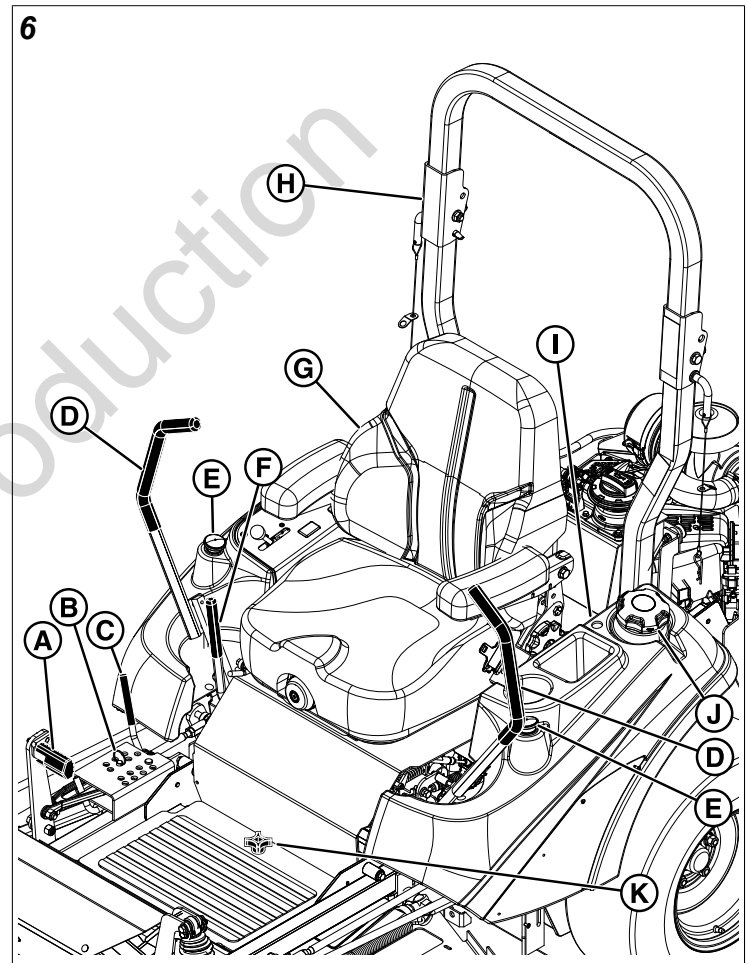

- A. Deck Lift Pedal
- B. Cutting Height Adjustment Pin
- C. Deck Lift Lock Lever
- D. Ground Speed Control Levers
- E. Fuel Level Gauge (One per fuel tank)
- F. Parking Brake
- G. Suspension Seat
- H. Roll Bar



- I. Fuel Selector Valve (Located Behind Seat on left side of the unit)
- J. Fuel Tank Cap (One per fuel tank)
- K. Removable Floor Plate
- L. Transmission Oil Fill / Tank (One per transmission)
- M. Transmission Release Levers (One per transmission)
- N. Seat Latch

**Deck Lift Pedal, Cutting Height Adjustment Pin & Deck Lift Lock Lever:** The deck lift pedal (A, Figure 7), the cutting height adjustment pin (B), and the deck lift lock lever (C) are used together to control the cutting height of the mower deck. See *Cutting Height Adjustment* for instructions on using these controls.

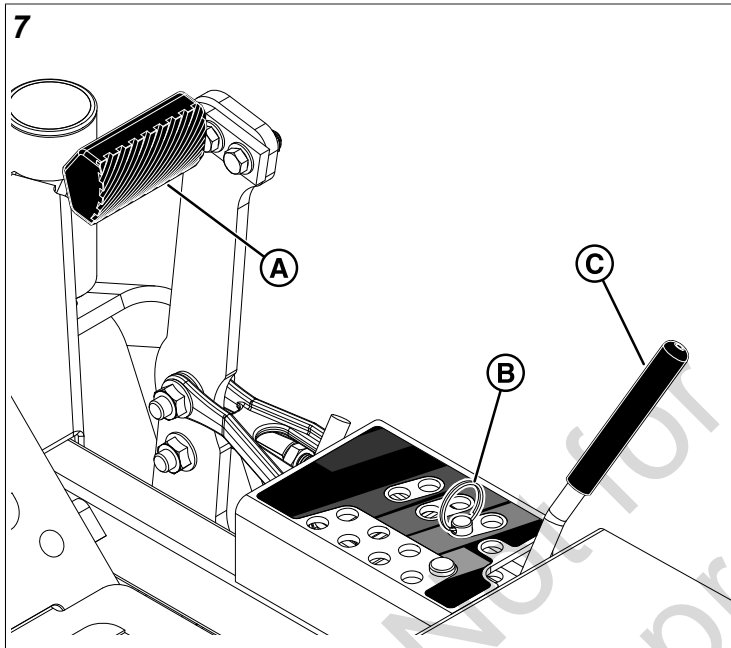

	Cutting Height Adjustment
	Storage Hole for Cutting Height Adjustment Pin
	Deck Lift Lock Lever

**Ground Speed Control Levers:** These levers control the ground speed and direction of the rider. The left lever controls the left rear drive wheel and the right lever controls the right rear drive wheel.

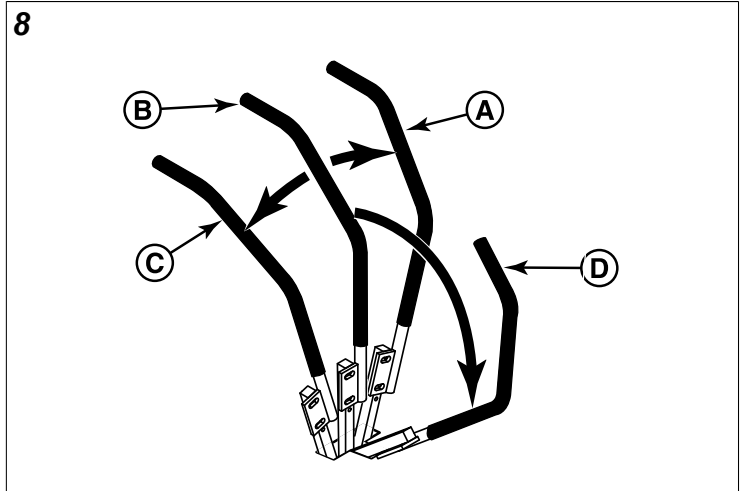

	FORWARD
	NEUTRAL
	REVERSE
N/A	NEUTRAL LOCKOUT POSITION

The parking brake must be disengaged before attempting to move the ground speed control levers from the NEUTRAL position.

Moving a lever forward (A) from the NEUTRAL position (B) increases the FORWARD speed of the associated wheel, and pulling back (C) on a lever increases the REVERSE speed.

Moving a levers outwards (D) from the NEUTRAL position locks the levers in the NEUTRAL LOCKOUT position.

*Note:* The further a lever is moved away from the neutral position the faster the drive wheel will turn.

See the *Zero-Turn Driving Practice* section for steering instructions.



**Fuel Level Gauge:** Displays the fuel level in the tank.



**Parking Brake:** Pull the parking brake lever up and back to engage the parking brake. Move the lever fully forward and down to disengage the parking brake.

*Note:* To start the unit the parking brake must be engaged.

Engaging the parking brake locks the ground speed control levers in the NEUTRAL position. The parking brake must be disengaged before moving the ground speed control levers out of the NEUTRAL position.

	<b>DISENGAGE:</b> Releases the parking brake.
	<b>ENGAGE:</b> Locks the parking brake.

**Suspension Seat:** This series of mower has multiple suspension seat options: a standard suspension seat (inset 1, Figure 9), and a suspension seat that has lumbar and back angle adjustments (inset 2). If your unit features a suspension seat, identify your suspension seat and follow the correct instructions below.

See Figure 9 and the list below for the location of the seat's features and a brief description of their functions.

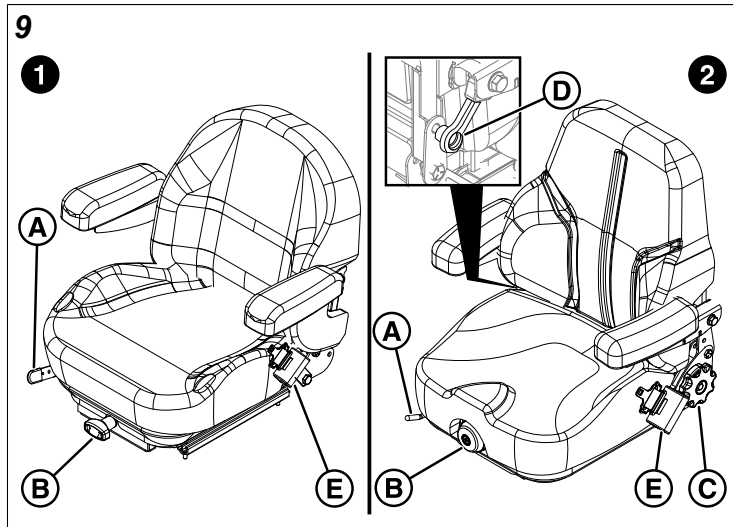

- A. **Seat Adjustment Lever (Forwards/Backwards):** The seat can be adjusted forwards and backwards. Move the forwards/backwards seat adjustment lever, position the seat as desired, and release the lever to lock the seat in position.
- B. **Seat Adjustment Knob (Suspension/Ride Comfort):** The seat adjustment knob adjusts the suspension of the seat (ride comfort). Turn the adjustment knob until the display scale has a reading that matches the weight of the operator.
- C. **Lumbar Adjustment Lever (Located underneath right hand arm rest):** Turn the lumbar adjustment knob until the desired amount of lumbar is achieved.
- D. **Back Angle Adjustment Knob:** Turn the back angle adjustment knob until the desired amount of back angle is achieved.
- E. **Retractable Seat Belt:** The seat belt is used to secure the operator to the seat.

**Fuel Selector Valve:** Turning the handle to the desired position determines which tank will be supplying fuel. With the handle pointing LEFT, it will draw fuel from the left-hand tank. With the handle pointing RIGHT, it will draw fuel from the right-hand fuel tank. With the handle pointing towards the operator, it will shut off fuel flow to the engine.

**Fuel Tank Cap:** To remove the cap, turn counter-clockwise.

**Removable Floor Plate:** The floor plate can be removed for easy access to the mower deck. To remove the plate, remove the retainer hardware and tilt the floor pan up and

then remove from the machine. Reverse the process for re-installation.

**Transmission Oil Fill:** Transmission oil is added through the hydraulic oil tanks. It also serves as extra holding capacity for oil as the transmissions heat up and the hydraulic oil expands. See *Check / Fill Transmission Oil* for oil level check and fill procedures.

#### Transmission Release Levers:

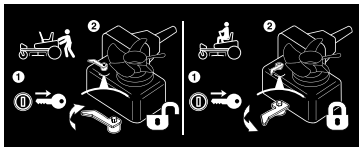
Icon	Control Name
	Transmission Release Levers

This unit is equipped with two transmission release levers. The transmission release levers deactivate the transaxle so that the unit can be pushed by hand. Both transmission release levers must be in the same position whether you are driving the unit or pushing it by hand. See *Pushing the Unit by Hand* for operational information.

**Seat Latch:** The seat latch (A, Figure 10) secures the seat plate to the frame of the unit

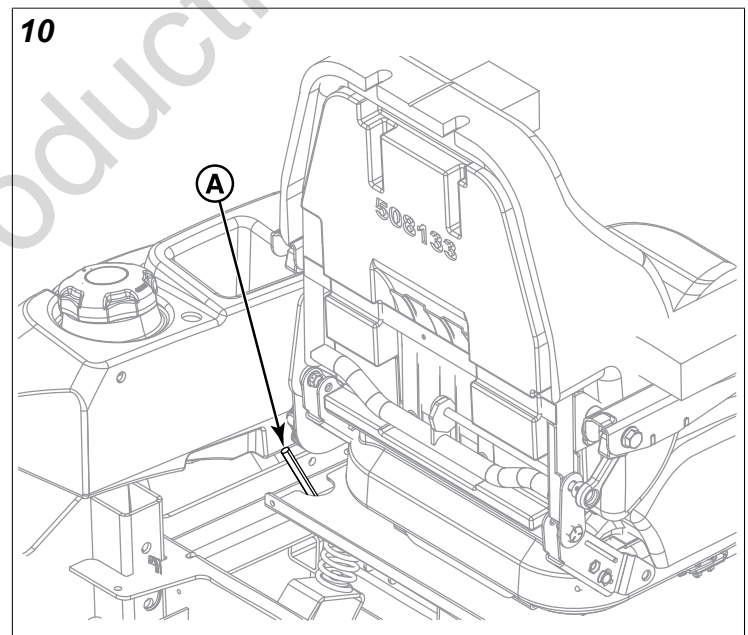

To raise the seat plate, release the latch by moving the seat latch towards the front of the unit and then raise the seat plate.

The seat latch is spring loaded. When the seat plate is lowered back into place the seat latch will lock the seat plate into place.

#### Instrument Control Panel Carbureted Models:

11

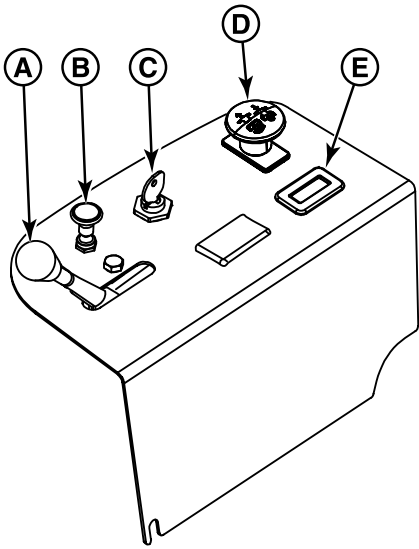

Fuel Injected Models:

12

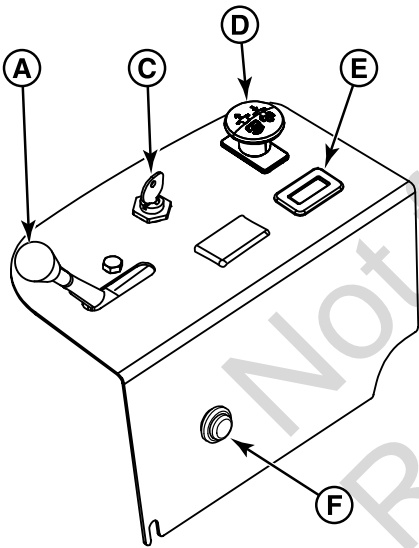

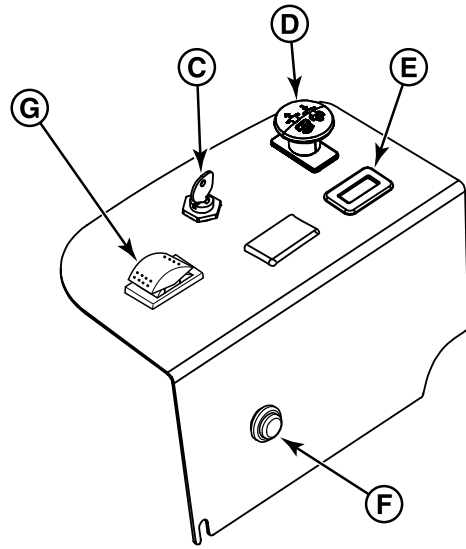

Kawasaki Fuel Injected Models:

13





Callout	Control Name
A	Throttle Control
B	Choke
C	Ignition Switch
D	PTO (Power Take Off) Switch
E	Hour Meter
F	Malfunction Indicator Lamp (M.I.L.)
G	Throttle Control Rocker Switch

**Throttle Control:** The throttle controls engine speed. Move the throttle forward to increase engine speed and back to decrease engine speed. Always operate at FULL throttle when mowing.

	Fast throttle speed.
	Slow throttle speed.

 **Choke:** Close the choke for cold starting. Open the choke once the engine starts. A warm engine may not require choking. Pull the knob UP to close the choke. Push the knob DOWN to open the choke.

**Ignition Switch:** The ignition switch starts and stops the engine, it has three positions:

	<b>OFF:</b> Stops the engine and shuts off the electrical system.
	<b>RUN:</b> Allows the engine to run and powers the electrical system.
	<b>START:</b> Cranks the engine for starting.

*Note:* Never leave the ignition switch in the RUN position with the engine stopped—this drains the battery.



**PTO (Power Take Off) Switch:** The PTO switch engages and disengages the mower blades. Pull UP on the switch to engage, and push DOWN to disengage.

**Hour Meter:** This unit is equipped with a dual function hour meter that records the number of hours that the engine has run and the number of hours that the PTO switch has been engaged.

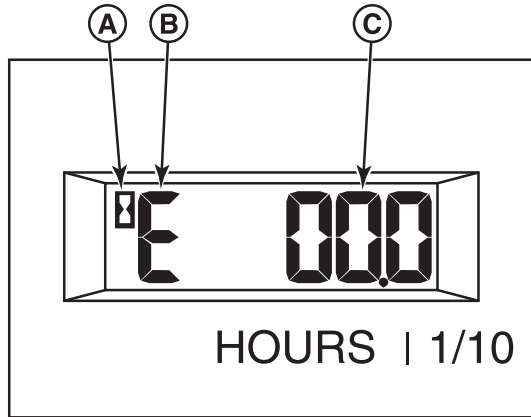

**"A" - Hour Glass Icon** - The hour glass icon flashes when the hour meter is recording the passage of time.

**"B" - Mode Icon** - The mode icon will display an "E" when displaying engine hours, and a "P" when displaying PTO hours.

**"C" - Time Display** - This is the number of hours that are recorded.

The default display of the hour meter is engine hours. The mode icon will display a "E" and the hour glass icon will not flash.

To begin recording engine hours, start the unit's engine and release the parking brake. The hour glass icon will flash.

To begin recording PTO hours, pull the PTO switch up to engage the PTO clutch. The unit's engine must be running. The mode icon will display a "P" and the hour glass icon will flash.

While recording PTO hours, the hour meter also records engine hours; however, the hour meter only displays PTO hours when recording PTO hours.

To stop recording PTO hours, push the PTO switch down to disengage the PTO clutch.

To stop recording engine hours, engage the parking brake.

The hour meter has a self contained power source so that the recorded hours are always visible even when the engine is OFF.

**Malfunction Indicator Lamp (M.I.L.):** The malfunction indicator lamp detects problems with the engine. If the malfunction indicator lamp begins to flash while you are operating the unit, see the engine operator's manual.

**Throttle Control Rocker Switch:** Pressing the throttle control rocker switch forward will increase the throttle position. Pressing the throttle control rocker switch backwards will decrease the throttle position. Always operate at FULL throttle when mowing.

	Fast throttle speed.
	Slow throttle speed.

## Operation

### Before First Time Operation

- Be sure to read all information in the Safety and Operation sections before attempting to operate this tractor and mower.
- Become familiar with all of the controls and how to stop the unit.
- Drive in an open area without mowing to become accustomed to the unit.



#### WARNING



- Never operate on slopes greater than 15°.
- Select slow ground speed before driving onto a slope. Use extra caution when operating on slopes with a rear-mounted grass catcher.
- Avoid turning down slopes; if possible turn up slopes. Use caution when changing direction on slopes and **do NOT start or stop on a slope.**



#### WARNING

- Never allow passengers to ride on the unit.
- Before leaving the operator's position for any reason, engage the parking brake, disengage the PTO, stop the engine and remove the key.
- To reduce fire hazard, keep the engine, rider and mower free of grass, leaves and excess grease. Do NOT stop or park rider over dry leaves, grass or combustible materials.
- Fuel is highly flammable and must be handled with care. Never fill the tank when the engine is still hot from recent operation. Do NOT allow open flame, smoking or matches in the area. Avoid over-filling and wipe up any spills.

## WARNING

Do NOT load this zero-turn rider on a trailer or truck using two separate ramps. Only use a single ramp that is at least one foot wider than the width of the rear wheels of this rider. This rider has a zero turning radius and the rear wheels could fall off the ramps, or the rider could tip over injuring the operator or bystanders.

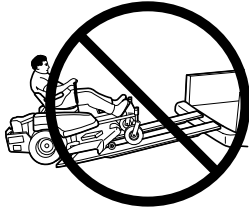

## Checks Before Starting

- Check that the crankcase is filled to the full mark on the crankcase oil fill and dipstick. If necessary, add oil through the engine oil fill. See the engine Operator's manual for instructions, engine oil dipstick location and oil recommendations.
- Make sure all nuts, bolts, screws and pins are in place and tight.
- Adjust the seat position, and make certain you can reach all the controls from operator's position.
- Fill the fuel tank with fresh fuel. Refer to engine manual for fuel recommendations.
- Check the hydraulic oil level.
- Make sure that the fuel selector valve is in an "ON" position.

## Starting the Engine - Carbureted Models

### WARNING

- If you do not understand how a specific control functions, or have not yet thoroughly read the *Features & Controls* section, do so now.
  - Do NOT attempt to operate the tractor without first becoming familiar with the location and function of all controls.
1. While sitting in the operator's seat, engage the parking brake and make sure the PTO switch is disengaged and the ground speed control levers are locked in the neutral position.
  2. **A warm engine may not require choking.** Set the engine throttle control to FAST throttle position. Then fully close the choke by pulling the knob OUT fully.
  3. Insert the key into the ignition switch and turn it to START.
  4. After the engine starts, gradually open the choke (push knob down fully). Reduce to half throttle speed and allow engine to warm. *Warm up the engine by running it for at least a minute before engaging the PTO switch or driving the rider.*

5. After warming the engine always operate the unit at FULL throttle when mowing.

***In the event of an emergency the engine can be stopped by simply turning the ignition switch to STOP.*** Use this method only in emergency situations. For normal engine shut down follow the procedure given in *Stopping the Rider*.

## Starting the Engine - Fuel Injected Models

### WARNING

- If you do not understand how a specific control functions, or have not yet thoroughly read the *Features & Controls* section, do so now.
- Do NOT attempt to operate the unit without first becoming familiar with the location and function of all controls.

*Note:* To prime a dry fuel system, turn key switch to RUN position for one minute. Allow fuel pump to cycle and prime system. Turn key switch OFF.

1. While sitting in the operator's seat, engage the parking brake and make sure the PTO switch is disengaged and the ground speed control levers are locked in the neutral position.
2. Position the throttle control midway between SLOW and FAST positions.
3. Insert the key into the ignition switch and turn it to START position. Release switch as soon as engine starts. If starter does not turn engine over, shut off key switch immediately, and consult engine operator's manual. *Warm up the engine by running it for at least a minute before engaging the PTO switch or driving the rider.*
4. After warming the engine always operate the unit at FULL throttle when mowing.

***In the event of an emergency the engine can be stopped by simply turning the ignition switch to STOP.*** Use this method only in emergency situations. For normal engine shut down follow the procedure given in *Stopping the Rider*.

## Starting the Engine - Kawasaki Fuel Injected Models

### WARNING

- If you do not understand how a specific control functions, or have not yet thoroughly read the *Features & Controls* section, do so now.
  - Do NOT attempt to operate the unit without first becoming familiar with the location and function of all controls.
1. While sitting in the operator's seat, engage the parking brake and make sure the PTO switch is disengaged and the ground speed control levers are locked in the neutral position.

2. Insert the key into the ignition switch and turn it to START position.
3. The throttle will self-adjust to idle when starting. After the engine starts allow the engine to warm. *Warm up the engine by running it for at least a minute before engaging the PTO switch or driving the rider.*
4. After warming the engine always operate the unit at FULL throttle when mowing.

**In the event of an emergency the engine can be stopped by simply turning the ignition switch to STOP.** Use this method only in emergency situations. For normal engine shut down follow the procedure given in *Stopping the Rider*.

## Stopping the Rider

1. Returning the ground speed control levers to the middle position will stop rider movement. Pivot the levers outward and lock them in NEUTRAL.
2. Disengage the PTO by pushing down on the PTO switch.
3. Engage the parking brake by pulling the handle up until it locks into position.
4. Move the throttle control to mid-throttle position and turn the ignition key to OFF. Remove the key.

## Zero-Turn Driving Practice

The lever controls of the Zero Turn rider are responsive, and learning to gain a smooth and efficient control of the rider's forward, reverse, and turning movements will take some practice.

Spending some time going through the maneuvers shown and becoming familiar with how the unit accelerates, travels, and steers — before you begin mowing — is absolutely essential to getting the most out of the Zero Turn rider.

**Locate a smooth, flat area of your lawn** — one with plenty of room to maneuver. (Clear the area of objects, people and animals before you begin.) Operate the unit at mid-throttle during this practice session (ALWAYS operate at full throttle when mowing), and turn slowly to prevent tire slippage and damage to your lawn.

We suggest you begin with the Smooth Travel procedure to the right, and then advance through the forward, reverse, and turning maneuvers.

You must release the parking brake prior to moving the control levers inward.

### Smooth Travel

The lever controls of the Zero Turn rider are responsive.

The BEST method of handling the ground speed control levers is in three steps — as shown in Figure 14.

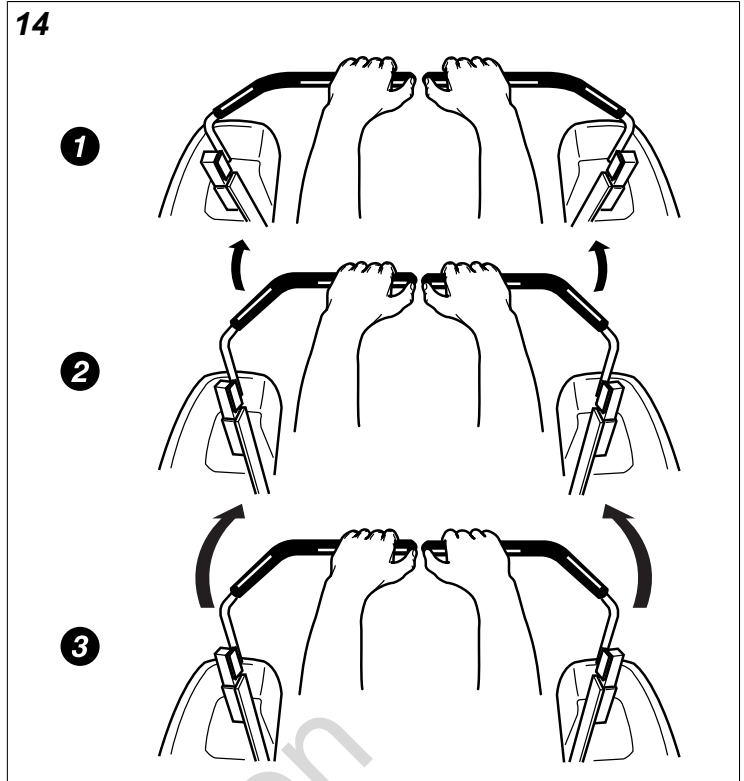

**FIRST** place your hands onto the levers as shown.

**SECOND**, to go forward gradually push the levers forward with your palms.

**THIRD**, to speed up move the levers farther forward. To slow down smoothly, slowly move the levers toward neutral.

## Basic Driving Forward Travel Practice

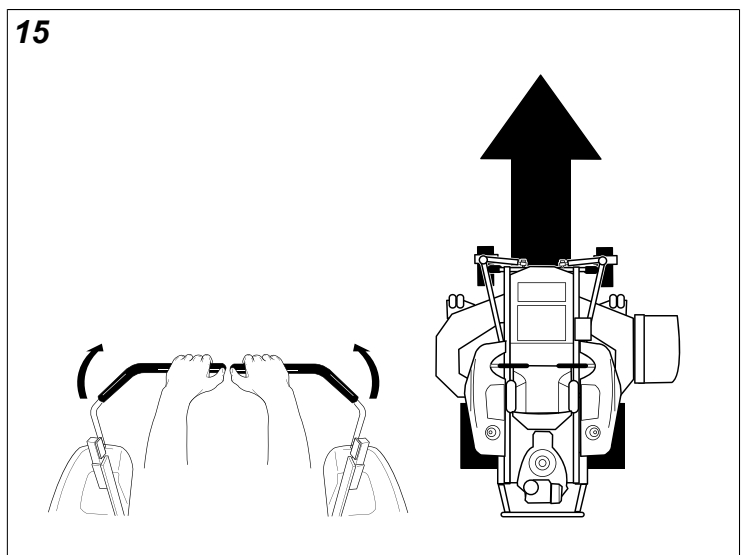

Gradually move both ground speed control levers — evenly FORWARD from neutral. Slow down and repeat.

*NOTE: Straight forward travel takes practice. If necessary, top speed can be balance-adjusted — see the Speed Balancing Adjustment in the Adjustments section near the back of this manual.*

## Reverse Travel Practice

16

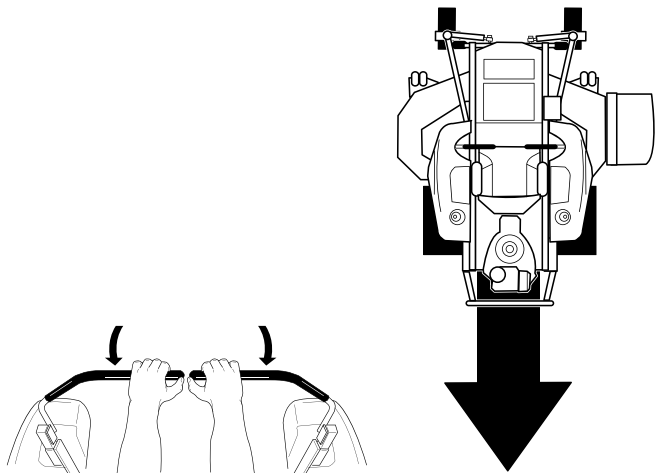

LOOK DOWN & BEHIND, then gradually move both ground speed control levers evenly BACK from neutral. Slow down and repeat.

*NOTE: Practice backing up for several minutes before attempting to do so near objects. The rider turns sharply in reverse as well as forward, and backing up straight takes practice.*

### Practice Turning Around A Corner

17

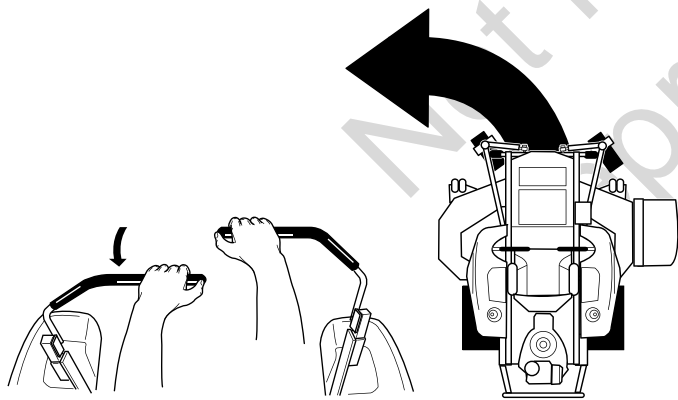

While traveling forward allow one handle to gradually return back toward neutral. Repeat several times.

*NOTE: To prevent pivoting directly on the tire tread, it is best to keep both wheels going at least slightly forward.*

### Practice Turning in Place

18

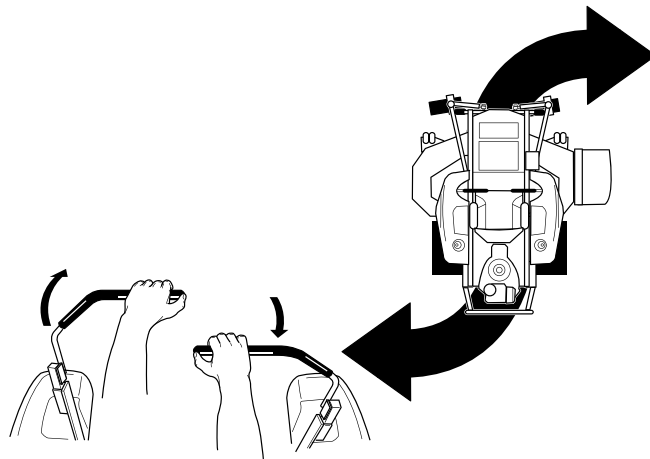

To turn in place, “Zero Turn,” gradually move one ground speed control lever forward from neutral and one lever back from neutral simultaneously. Repeat several times.

*NOTE: Changing the amount each lever is pulled—forward or back, changes the “pivot point” you turn on.*

## Advanced Driving

### Executing an End-Of-Row Zero Turn

19

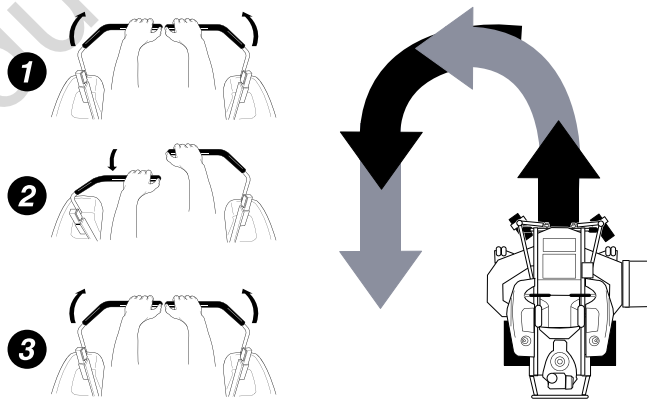

Your Zero Turn Rider’s unique ability to turn in place allows you to turn around at the end of a cutting row rather than having to stop and Y-turn before starting a new row.

For example, to execute a left end-of row zero turn:

1. Slow down at the end of the row.
2. Move the RIGHT ground speed control lever forward slightly while moving the LEFT ground speed control lever back to center and then slightly back from center.
3. Begin mowing forward again.

This technique turns the rider LEFT and slightly overlaps the row just cut—eliminating the need to back up and re-cut missed grass.

As you become more familiar and experienced with operating the Zero Turn rider, you will learn more maneuvers that will make your mowing time easier and more enjoyable.

**Remember, the more you practice, the better your control of the Zero Turn will be!**

## Mowing

1. Engage the parking brake. Make sure that the PTO switch is disengaged, the ground speed control levers are locked in the NEUTRAL position and the operator is in the seat.
2. Start the engine. See *Starting the Engine*.
3. Set the mower cutting height.
4. Set the throttle to the 1/2 throttle position.

*Note:* It is best practice to engage the PTO with the throttle set at the minimum throttle position necessary to engage the deck drive system without stalling the engine.

5. Engage the PTO by pulling up on the PTO switch.
6. Move the throttle to the "FAST" position and begin mowing.
7. When finished, reduce throttle speed so that the engine idles and push the PTO switch down to shut off the PTO.
8. Stop the engine. See *Stopping the Rider*.

## Mowing Recommendations

Several factors can affect how well your machine cuts grass. Following proper mowing recommendations can improve the performance and life of your machine.

### Height of Grass

Often cutting height is a matter of personal preference. Typically, you should mow the grass when it is between three and five inches high. The proper cutting height range for a specific lawn will depend upon several factors, including the type of grass, the amount of rainfall, the prevailing temperature, and the lawn's overall condition.

Cutting the grass too short causes weak, thin grass plants, which are easily damaged by dry periods and pests. Cutting too short is often more damaging than allowing the grass to be slightly higher.

Letting grass grow a bit longer—especially when it is hot and dry—reduces heat build-up, preserves needed moisture and protects the grass from heat damage and other problems. However, allowing grass to grow too high can cause thin turf and additional problems.

Cutting off too much at one time shocks the plant's growth system and weakens the grass plants. **A good rule of thumb is the 1/3 rule: to cut no more than one third of the grass height, and never more than 1 inch at a time.**

20

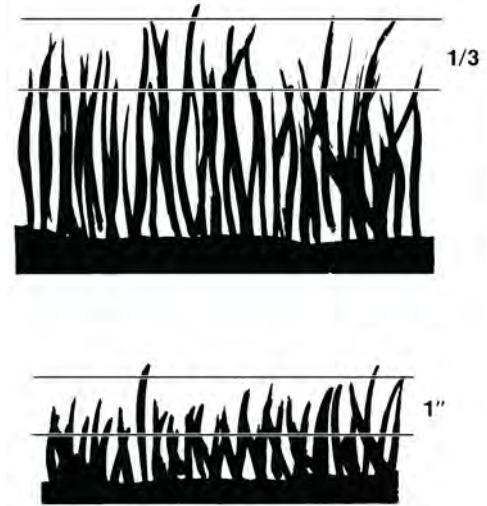

The amount of grass you are able to cut in one pass is also effected by the type of mowing system you are using (for example, broadcasting with side discharge decks can process a much larger volume of grass than mulching does).

**Tall grass requires incremental cutting.** For extremely tall grass, set the cutting height at maximum for the first pass (A, Figure 21), and then reset it to the desired height and mow a second (B) or third time.

Don't cover the grass surface with a heavy layer of clippings. Consider using a grass collection system and starting a compost pile.

21

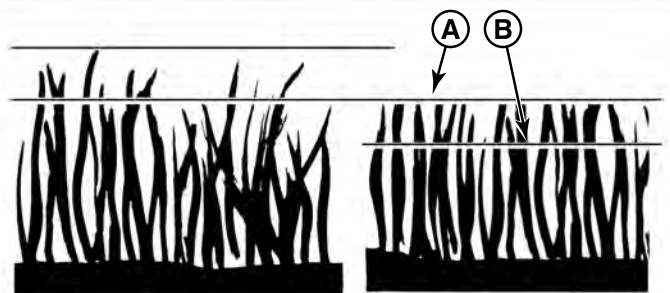

## When and How Often to Mow

The time of day and condition of the grass greatly affect the results you'll get when mowing. For the best results, follow these guidelines:

- Mow when the grass is between three and five inches high.
- Mow with sharp blades. Short clippings of grass one inch or shorter decompose more quickly than longer blades. Sharp mower blades cut grass cleanly and efficiently, preventing frayed edges which harm the grass.
- Mow at time of day when the grass is cool and dry. Late afternoon or early evening often provide these ideal mowing conditions.



- Avoid mowing after rain or even heavy dew, and never mulch when the grass is wet (moist grass does not mulch well, and clumps beneath the mower deck).

## Mowing Patterns

Always start mowing on a smooth, level area.

The size and type of area to be mowed will determine the best mowing pattern to use. Obstructions such as trees, fences and buildings, and conditions such as slopes and grades must also be considered.

- Cut long straight strips overlapping slightly.
- Where possible, change patterns occasionally to eliminate matting, graining or a corrugated appearance.
- For a truly professional cut, mow across the lawn in one direction, then re-cut the lawn by mowing perpendicular to the previous cut.

*Note:* Always operate the engine at FULL THROTTLE when mowing.

If you hear the engine slowing down, you are mowing too fast—using a slower ground speed will improve the cutting efficiency of the blades and prevents many common cutting problems. Use an appropriate ground speed for the thickness and height of the grass you are cutting (3rd gear or slower for manual gear models). If you hear the engine slowing down you are mowing too fast, use a slower ground speed.

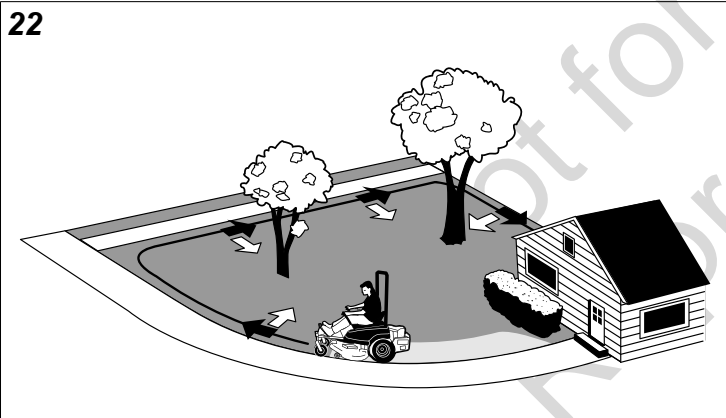

Where possible, make one or two passes around the outside of the area discharging the grass INTO the lawn to keep the cut grass off fences and walks.

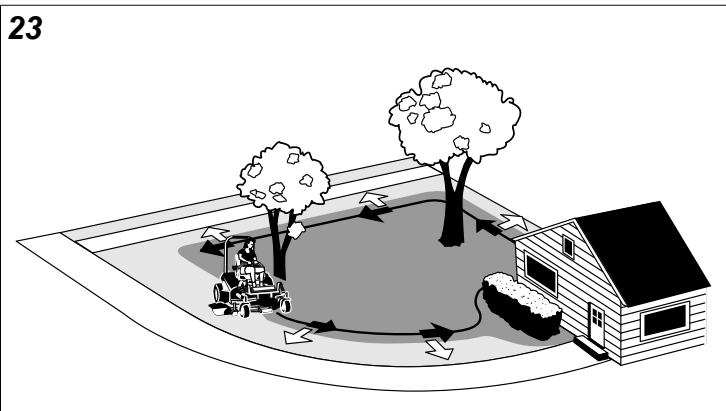

The remainder of the mowing should be done in the opposite direction so that the clippings are dispersed OUT onto the area of lawn previously cut.

## Mowing Methods

### Broadcast Mowing

Broadcasting, or side-discharging, disperses fine clippings evenly over the entire lawn. Many golf courses use this method. Your mower has a deep dish deck to allow freer circulation of clippings so they are broadcast evenly over the lawn.

Engine Speed & Ground Speed for Broadcasting:

Always operate the engine at full throttle when mowing. If you hear the engine slowing down, you are mowing too fast—using a slower ground speed will improve the cutting efficiency of the blades and prevents many common cutting problems.

ALWAYS use an appropriate ground speed for the thickness and height of the grass you are cutting (3rd gear or slower for manual gear models). If you hear the engine slowing down you are mowing too fast, use a slower ground speed.

How Much Grass to Cut Off When Broadcasting:

Mow when the grass is 3-5 inches long. Do not cut the grass shorter than 2 to 2-1/2 inches. Do not cut off more than 1 inch of grass in a single pass.

### Mulching

Mulching consists of a mower deck which cuts and re-cuts clippings into tiny particles and which then blows them down INTO the lawn. These tiny particles decompose rapidly into by-products your lawn can use. UNDER PROPER CONDITIONS, your mulching mower will virtually eliminate noticeable clippings on the lawn surface.

*Note:* When mulching under heavy cutting conditions, a rumbling sound may be present and is normal.

Mulching Requires EXCELLENT Mowing Conditions:

Mulching mowers cannot function properly if the grass is wet, or if the grass is simply too high to cut. Even more than normal mowing, mulching requires that the grass be dry and the appropriate amount is cut.

Do not use the mower as a mulching mower during the first two or three mowings in the spring. The long grass blades, quick growth, and often wetter conditions are more suitable for broadcasting (side-discharging) or grass bagging operation.

Engine Speed & Ground Speed for Mulching:

Use full engine throttle matched with a slow ground speed so that clippings will be finely cut. Ground speed while mulching should be HALF of the speed that would be used when broadcasting (side discharging) under similar conditions. Since mulching requires more horsepower than broadcasting, using a slower ground speed is vitally important for proper mulching operation.

How Much Grass to Mulch:

The best mulching action typically results from cutting only the top ½ inch to ¾ inch of grass blade. This provides short clippings which decompose properly (much more quickly than longer clippings). The ideal cutting height will vary with climate, time of year, and quality of your lawn. We recommend that you experiment with both the cutting height and ground speed until you achieve the best cut. Start with a high cutting height and using progressively lower settings until you find a cutting height that is matched to your mowing conditions and preferences.

## Pushing the Rider By Hand

### NOTICE

Do NOT tow zero-turn rider.

Towing the units will cause hydraulic transmission damage. Do not use another vehicle to push or pull this unit.

1. Disengage the PTO, engage the parking brake, turn the ignition OFF, and remove the key.
2. Locate the transmission release lever on top of the transmission of the unit. There is one transmission release lever on each transmission. The transmission release levers open and close the transmission bypass valves.
3. To open the transmission bypass valves rotate the transmission release levers to the "bypass" position (A, Figure 24). The transmission release levers will contact the bodies of the transmissions. The transmission release levers will be oriented so that they are perpendicular to the axles of the transmissions.

24

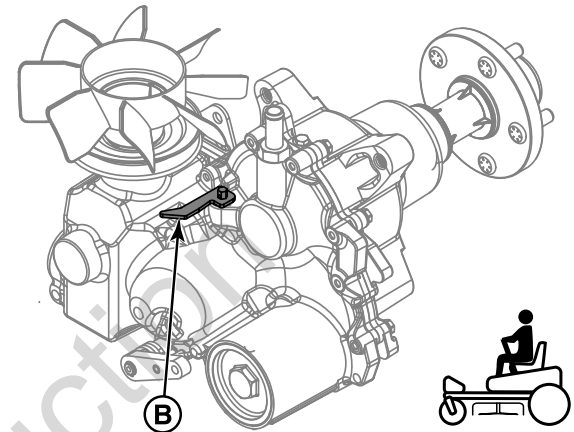
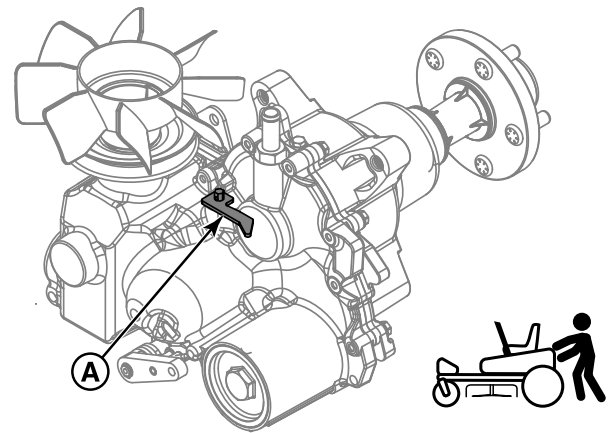

4. Disengage the parking brake. The zero-turn rider can now be pushed by hand.
5. After moving the zero-turn rider, close the bypass valves by rotating the transmission release levers to the "run" position (B). The transmission release levers will contact the bodies of the transmissions. The transmission release levers will be oriented so that they are parallel to the axles of the transmissions.

*Note:* Both transmission release levers must be in the same position.

## Raise and Lower the Roll Bar



**Avoid serious injury or death from roll over:**

- Keep roll bar in the raised position and use the seat belt.
- There is no roll over protection when the roll bar is down.
- Lower the roll bar only when necessary and NEVER remove it.
- Do NOT use seat belt when the roll bar is down.
- Raise the roll bar as soon as clearance permits.
- Do NOT jump off if the mower tips.

**To lower the roll bar:**

1. Pull the hair pin clips (A, Figure 25) out of the retainer pins (B).

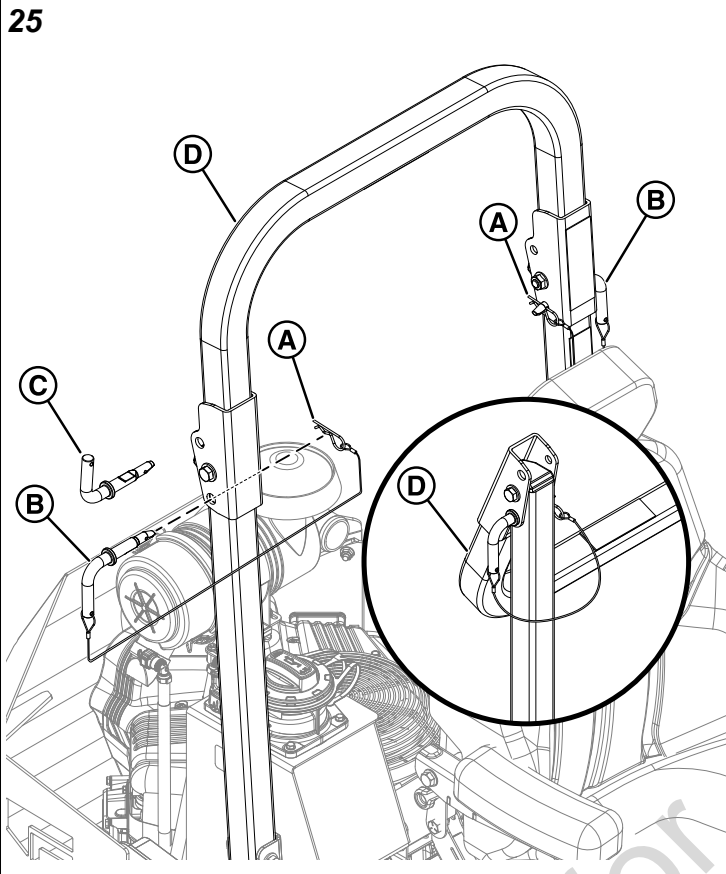

2. Rotate the retainer pins so that the handle of the pin is pointing up (C).
3. Remove the retainer pins. You may need to push or pull on the top loop (D) of the roll bar in order to pull the pins out of the roll bar.
4. Lower the roll bar.
5. With the handles of the retainer pins pointing up, install the retainer pins into the roll bar and secure the roll bar into the down position.
6. Rotate the retainer pins so that the handle of the pin is pointing down and then install the hair pin clips into the retainer pins.

#### To raise the roll bar:

1. Pull the hair pin clips (A, Figure 25) out of the retainer pins (B).
2. Rotate the retainer pins so that the handle of the pin is pointing up (C).
3. Remove the retainer pins.
4. Raise the top loop (D) of the roll bar into position.
5. With the handles of the retainer pins pointing up, install the retainer pins into the roll bar and secure the roll bar into the raised position.
6. Rotate the retainer pins so that the handle of the pin is pointing down and then install the hair pin clips into the retainer pins.

## Attaching a Trailer

The maximum weight of a towed trailer should be less than 200 lbs (91kg). Secure the trailer with an appropriately sized clevis pin (A, Figure 26) and clip (B).

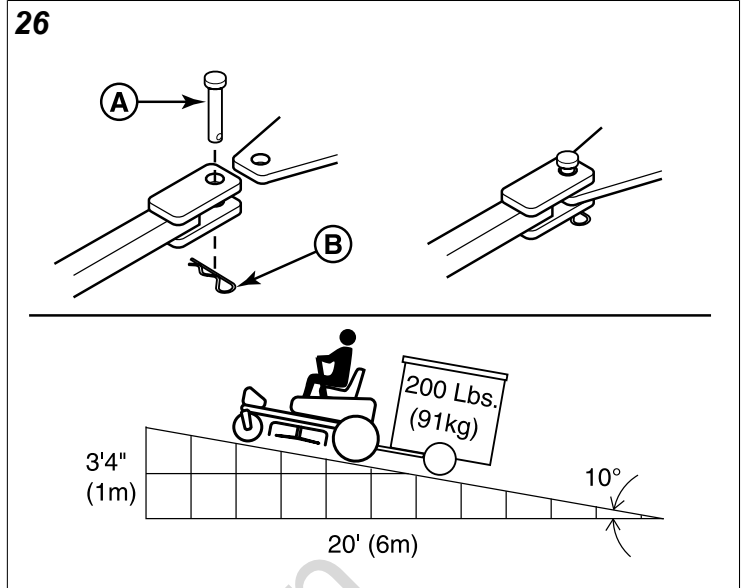

Excessive towed loads can cause loss of traction and loss of control on slopes. Reduce towed weight when operating on slopes. The surface being driven on greatly impacts traction and stability. Wet or slippery surfaces can greatly reduce traction and the ability to stop or turn. Carefully evaluate the surface conditions before operating the unit and trailer, and never operate on slopes greater than 10°. See SLOPE OPERATION and TOWED EQUIPMENT in the safety section of this manual for additional safety information.

## Storage

### Temporary Storage (30 Days or Less)

Remember, the fuel tank will still contain some gasoline, so never store the unit indoors or in any other area where fuel vapor could travel to any ignition source. Fuel vapor is also toxic if inhaled, so never store the unit in any structure used for human or animal habitation.

### WARNING

Never store the unit, with gasoline in engine or fuel tank, in a heated shelter or in enclosed, poorly ventilated enclosures. Gasoline fumes may reach an open flame, spark or pilot light (such as a furnace, water heater, clothes dryer, etc.) and cause an explosion.

Handle gasoline carefully. It is highly flammable and careless use could result in serious fire damage to your person or property.

Drain fuel into an approved container outdoors away from open flame or sparks.

Here is a checklist of things to do when storing your unit temporarily or in between uses:

- Keep the unit in an area away from where children may come into contact with it. If there's any chance of

unauthorized use, remove the spark plug (s) and put in a safe place. Be sure the spark plug opening is protected from foreign objects with a suitable cover.

- If the unit can't be stored on a reasonable level surface, chock the wheels.
- Clean all grass and dirt from the mower.

### Long Term Storage (Longer Than 30 Days)

Before you store your unit for the off-season, read the Maintenance and Storage instructions in the Safety Rules section, then perform the following steps:

1. Drain crankcase oil while engine is hot and refill with a grade of oil that will be required when unit is used again.
2. Prepare the mower deck for storage as follows:
  - a.) Remove mower deck from the unit.
  - b.) Clean underside of mower deck.
  - c.) Coat all bare metal surfaces with paint or light coat of oil to prevent rusting.
3. Clean external surfaces and engine.
4. Prepare engine for storage. See engine owner's manual.
5. Clean any dirt or grass from cylinder head cooling fins, engine housing and air cleaner element.
6. Cover air cleaner and exhaust outlet tightly with plastic or other waterproof material to keep out moisture, dirt and insects.
7. Completely grease and oil unit as outlined in the *Lubrication* section.
8. Clean up unit and apply paint or rust preventative to any areas where paint is chipped or damaged.
9. Be sure the battery is filled to the proper level with water and is fully charged. Battery life will be increased if it is removed, put in a cool, dry place and fully charged about once a month. If battery is left in unit, disconnect the negative cable.
10. Drain fuel system completely or add a gasoline stabilizer to the fuel system. If you have chosen to use a fuel stabilizer and have not drained the fuel system, follow all safety instructions and storage precautions in this manual to prevent the possibility of fire from the ignition of gasoline fumes. Remember, gasoline fumes can travel to distant sources of ignition and ignite, causing risk of explosion and fire.

*NOTE: Gasoline, if permitted to stand unused for extended periods (30 days or more), may develop gummy deposits which can adversely affect the engine carburetor and cause engine malfunction. To avoid this condition, add a gasoline stabilizer to the fuel tank and run the engine a few minutes, or drain all fuel from the unit before placing it in storage.*

### Starting After Long Term Storage

Before starting the unit after it has been stored for a long period of time, perform the following steps.

1. Remove any blocks from under the unit.
2. Install the battery if it was removed.
3. Unplug the exhaust outlet and air cleaner.

4. Fill the fuel tank with fresh gasoline. See engine manual for recommendations.
5. See engine owner's manual and follow all instructions for preparing engine after storage.
6. Check crankcase oil level and add proper oil if necessary. If any condensation has developed during storage, drain crankcase oil and refill.
7. Inflate tires to proper pressure. Check fluid levels.
8. Start the engine and let it run slowly. DO NOT run at high speed immediately after starting. Be sure to run engine only outdoors or in well ventilated area.

## Maintenance Schedule

The following schedule should be followed for normal care of your unit. You will need to keep a record of your operating time. Determining operating time is easily accomplished by observing the hour meter.

If your unit is equipped with a dual function hour meter that displays both engine hours and PTO hours, the maintenance intervals are based on the engine hours as displayed by the hour meter.

UNIT MAINTENANCE	
<b>Before Each Use</b>	
Check safety interlock system.	
Check unit's brakes.	
Check unit for loose hardware.	
Check hydraulic oil level.	
<b>Every 25 Hours</b>	
Clean deck and check / replace mower blades.*	
Lubricate unit.*	
Check tire pressures.	
<b>Every 50 Hours</b>	
Lubricate ForeFront™ suspension control arms.	
<b>Every 100 Hours</b>	
Check mower blade stopping time.	
Clean battery and cables.	
Initial change of hydraulic oil.	
<b>Every 400 Hours or Yearly</b>	
Change hydraulic oil and filter.	

ENGINE MAINTENANCE	
<b>Before Each Use</b>	
Check engine oil level.	
<b>Every 25 Hours</b>	
Check / Clean cooling fins and intake.*	
<b>Every 50 Hours</b>	
Check / Clean spark arrester.**	
<b>Refer to Engine Owner's Manual</b>	

## ENGINE MAINTENANCE

- Service air filter.
- Change engine oil and filter.\*
- Check / Replace spark plugs.
- Check / Replace fuel filter.

\*More often in hot (Over 85°F, 30°C) weather or dusty operating conditions.

\*\*If equipped, replace if damaged.

## Maintenance Procedures

### Service and Maintenance Safety



**WARNING**

#### Amputation and crushing hazard

Specific steps must be taken in order to perform service and maintenance procedures safely.

Read and follow all the applicable safety and instructional messages in this manual.

Always disengage the mower blades, set the parking brake, turn the engine OFF, remove the ignition key, and wait for all movement to stop prior to performing service and maintenance procedures.

Always disconnect the spark plug wire(s) and fasten it away from the plug before beginning any maintenance or service procedures in order to prevent accidental ignition.

## Before Maintaining Your Unit

### Units Equipped with Electronic Fuel Injected Engines:

If electric welding on vehicle, remove battery negative cable (black) from battery negative (-) terminal, and disconnect the ECM electrical connector(s). If welding on the muffler, also disconnect the O2 sensor electrical connector and remove the O2 sensor from the muffler.

## Checking / Adding Fuel



**WARNING**

Gasoline is highly flammable and must be handled with care. Allow engine to cool for at least 3 minutes before refueling. Do not allow open flame, smoking or matches in the area. Avoid over-filling and wipe up any spills.

#### To add fuel:

1. Remove the fuel cap (A, Figure 27).

27

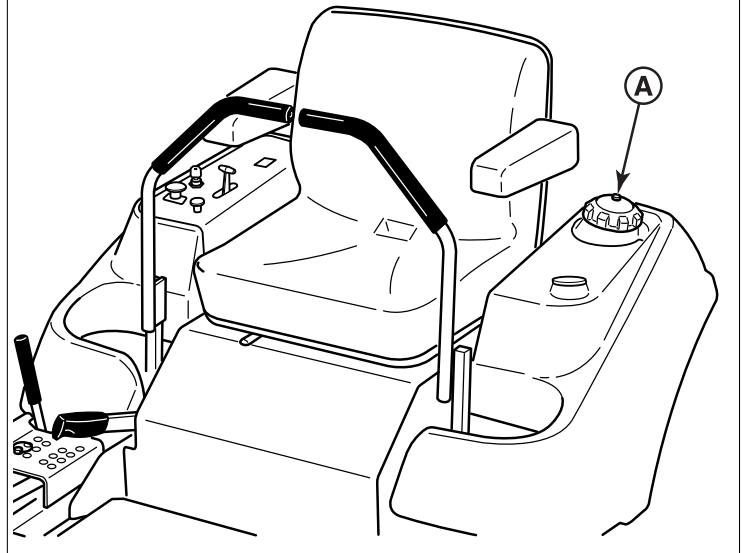

2. Fill the fuel tank to the bottom of the filler neck. This will allow for fuel expansion.  
Note: Do not overfill. Refer to your engine owner's manual for specific fuel recommendations.
3. Install and hand tighten the fuel cap.
4. If your unit is equipped with two fuel tanks, repeat this process to fill the other fuel tank.

#### **NOTICE**

Refer to your engine owner's manual for specific fuel recommendations.

## Replacing the Fuel Filter



**WARNING**

**Fuel and its vapors are extremely flammable and explosive.**

**Fire or explosion can cause severe burns or death.**

Do NOT remove the fuel filter when the engine is hot, as spilled gasoline may ignite. Do NOT spread hose clamps further than necessary. Ensure clamps grip hoses firmly over filter after installation.

**Carbureted Models:** The fuel filter is located in the fuel line between fuel tank and carburetor, near the fuel pump.

**Fuel Injected Models:** The fuel filter is located in the fuel line between the fuel tank and fuel pump.

If filter is dirty or clogged, replace as follows:

1. Disconnect the negative battery cable.
2. Place a container below the filter to catch spilled fuel.
3. Using a pliers, open and slide hose clamps from fuel filter.
4. Remove hoses from filter.
5. Install new filter in proper flow direction in fuel line.
6. Secure with hose clamps.
7. Reconnect the negative battery cable when finished.

## Check Engine Oil Level

**Interval:** Before Each Use

Refer to the engine owners manual for dipstick and oil fill locations and specific engine oil check and fill procedures.

## Briggs & Stratton Vanguard Engines with Remote Oil Tank (Select Models)

Some models in this series of mower feature a remote oil tank (A, Figure 28) that supplies oil to the engine. Units equipped with a Vanguard engine with remote oil tank are factory filled with specially formulated Vanguard 15W-50 synthetic oil.

*Note:* This specific grade of oil is not required to keep engine warranty in effect.

For more information regarding this engine and other operational and maintenance information, please refer to the engine operator's manual included with your unit.

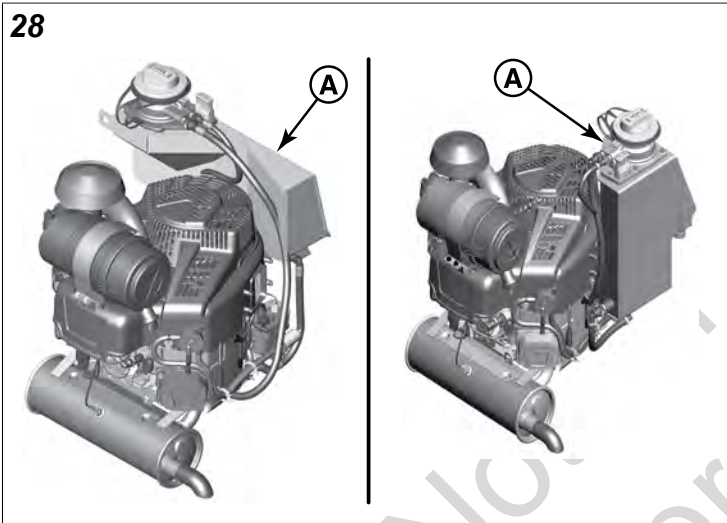

## Changing the Engine Oil and Filter (Engines with Remote Oil Tank)

**Engine Oil Type:** 15W-50 synthetic oil. (See the engine operator's manual for other oil recommendations.)

**Engine Oil Change Amount:** 5 qt (4,73 L).

**Oil Change Interval:** Every 500 hours.

*Important:* Always make sure that the mower is parked on a flat, level surface when checking the engine oil level.

1. Park the machine on a flat, level surface. Engage the parking brake and disengage the PTO. Allow the engine to run until it is warm. This will warm the oil so it will drain better. Turn the ignition switch to OFF, remove the ignition key, and wait for all moving parts to stop before leaving the operator's position.
2. Clean the area around the engine oil dipstick (A, Figure 29) and oil fill cover (B) to remove any debris.

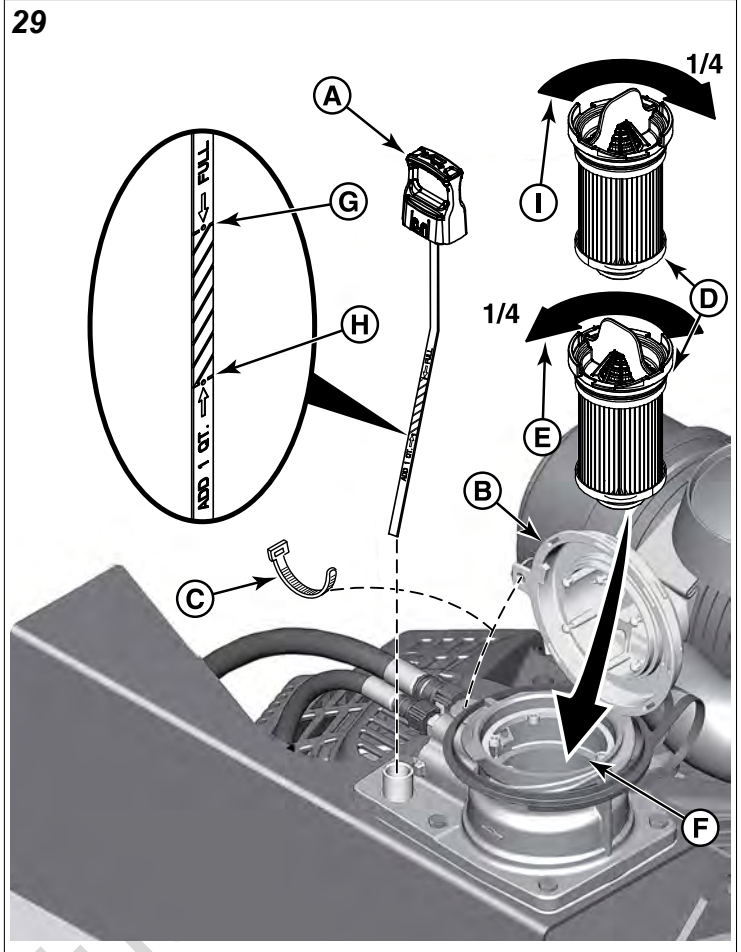

3. Remove the engine oil dipstick and wipe with a clean cloth.
4. Cut the self-locking tie (C) that keeps the oil fill cover securely closed. Open the oil fill cover.
5. Have a suitable container ready to capture dripping oil from the engine oil filter (D) after it is removed. Remove the oil filter by turning it **counter-clockwise** a 1/4 turn (E) and then pulling up. Dispose of the used oil filter properly.
6. This mower is equipped with an oil drain valve (A, Figure 30) that is used to drain the oil from the remote oil tank. The drain is located on the left side of the engine at the rear of the machine. The drain is routed through the unit's engine deck. To catch the drained engine oil, place a suitable container underneath the unit's engine deck.

30

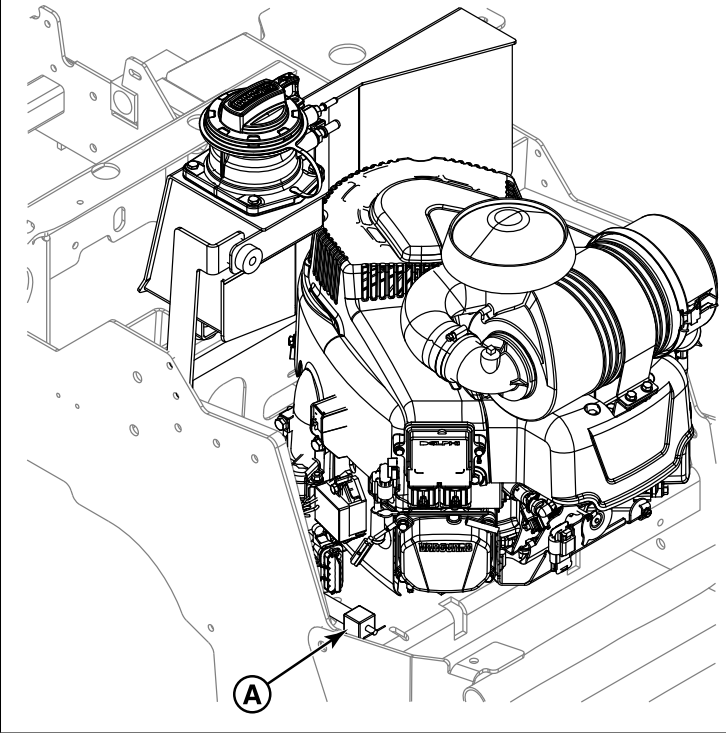

7. Remove the cap from the drain spout of the oil drain valve.
8. To operate the oil drain valve, turn **counter-clockwise** to open and drain the engine oil into a suitable container.
9. After the engine oil has drained, turn the oil drain valve **clockwise** to close and re-install the cap on the oil drain valve.
10. Pour oil into the engine oil fill (F, Figure 29). The remote oil tank is designed to hold 5 qt (4,73 L) of engine oil.
11. Install the engine oil dipstick (A, Figure 31) into the tank by pressing down firmly with your hand. The engine oil dipstick has a detent (B) and it must snap into place on the lip (C) of the tank housing so that the dipstick is fully installed into the tank. This action requires moderate force.

31

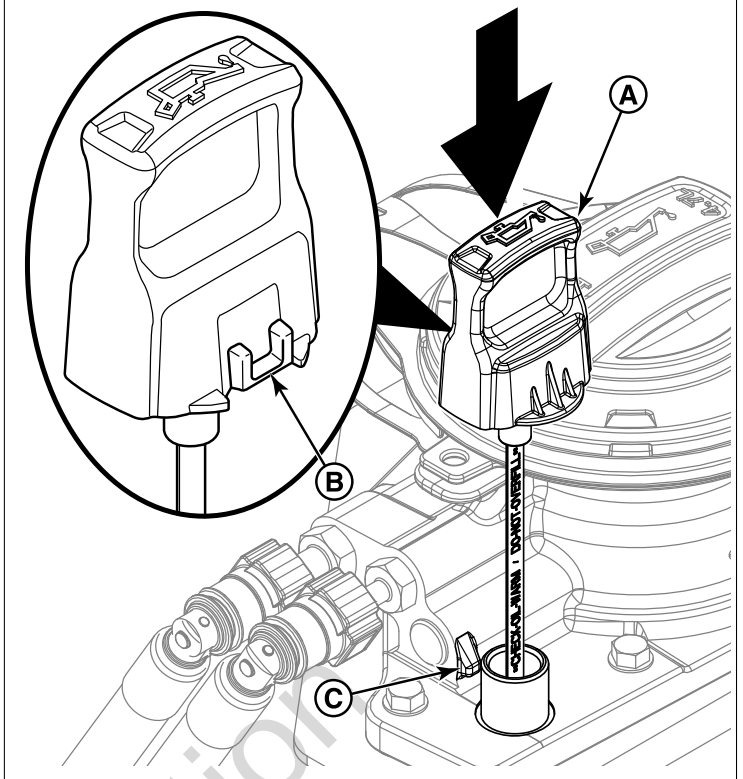

12. Remove the engine oil dipstick and check the oil level. Maximum oil level is the "FULL" line (G, Figure 29) on the dipstick. If the oil level is at or below the "ADD 1 QT." line (H), add more oil.
13. Re-install the dipstick.
14. Install a new engine oil filter by lowering it into the engine oil fill and then turning **clockwise** a 1/4 turn (I).
15. Close the oil fill cover.
16. Start and run the engine. As the engine warms up, check for oil leaks.
17. Stop the engine and check oil level. Add more if necessary.
18. If desired, a new self-locking tie can be installed to keep the oil fill cover securely closed.

## Changing the Engine Oil and Filter (All Other Models)

This series of mower has different engine options: Briggs & Stratton Vanguard Series (A, Figure 32), Kawasaki FX Series and Kawasaki FT Series (B). Please reference figure 32 as the location of the components listed for this procedure may vary by specific engine option.

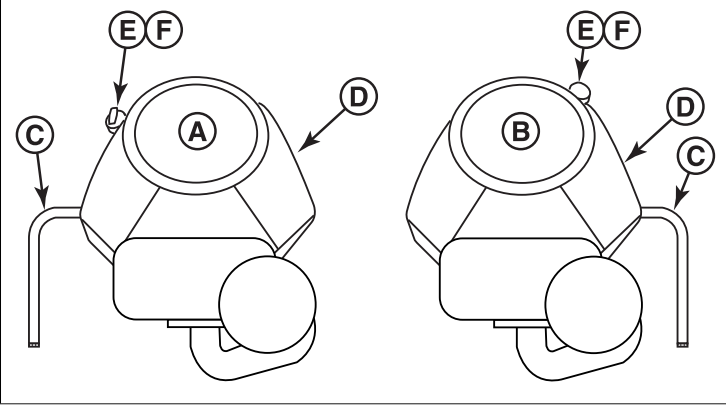

1. Warm engine by running for a few minutes. (Refer to the engine operator's manual for oil & filter replacement instructions.)
2. Remove the oil drain hose (C) from its storage position and route the hose so that when the oil drain cap is removed the oil can be drained into a small pan.
3. Place a small pan under the oil drain hose to catch the oil. Using the appropriate tools, remove the oil drain cap from the oil drain hose and drain the engine oil.
4. After draining, replace the cap and wipe up any spilled oil. Reinstall the oil drain hose to its storage position so it is retained during normal operation.
5. Place an absorbent shop cloth under the engine oil filter (D). Remove the engine oil filter and replace with a new one.
6. Add engine oil (refer to engine operator's manual) in the fill tube (E) and check the amount of oil in the engine using the engine oil dipstick (F).
7. Remove the shop cloth and wipe up any spilled oil.

## Clean the Engine Compartment Area with Pressurized Air and Water

Pressurized air and/or water can cause debris and/or hot water to be blown out. This action could result in personal injury.

When pressurized air and/or pressurized water is used for cleaning wear protective clothing, protective shoes, and eye protection. Eye protection includes goggles or a protective face shield.

The maximum air pressure for cleaning purposes must be below 205 kPa (30 psi). The maximum water pressure for cleaning purposes must be below 275 kPa (40 psi).

## Engine Maintenance

For engine maintenance schedules and procedures, please refer to the engine operator's manual.

## Containing Spilled Fluids and Proper Disposal of Waste

Make sure that fluids are contained when performing inspection, maintenance, testing, adjustment, and repair

of the unit. Be prepared to collect the fluid with suitable leakproof containers before opening or disassembling any component containing fluids. Do not pour waste onto the ground, down a drain, or into any source of water.



Improper disposal of waste can threaten the environment. Dispose of all fluids according to local regulations and mandates.

## Electronic Fuel Injection (EFI) System - EFI Models

EFI is an electronically-controlled fuel management system which is monitored by an Electronic Control Unit (ECU). A Malfunction Indicator Lamp (M.I.L.) will illuminate if problems or faults are detected. Servicing by an authorized dealer is necessary.



### CAUTION

Do not disconnect or reconnect ECU wiring harness connector or any individual components with the ignition switch in the "ON" position. This can send a damaging voltage spike through the ECU.

Unplug harness from ECU before performing any welding on equipment.

## Inspect Muffler and Spark Arrester

Inspect the muffler for cracks, corrosion, or other damage. Remove the spark arrester, if equipped, and inspect for damage or carbon blockage. If replacement parts are required, make sure to use only original equipment replacement parts.



### WARNING

Replacement parts must be the same and installed in the same position as the original parts or fire could result.

## Fuse Location and Identification

The electrical system for this unit is equipped with two replaceable fuses. See the chart below for the circuit, amperage, and approximate location of the fuses.

Circuit	Amperage	Approximate Location
Main	25 amp	Instrument control panel.
PTO Clutch	15 amp	Behind the seat on the left hand side of the machine.

## Check / Fill Transmission Oil Level

This unit is equipped with two transmission oil tanks. One transmission oil tank only supplies oil to one transmission. The level of oil in both transmission tanks must be checked, and if necessary, filled.

**Oil Type:** SAE 20W-50 motor oil



1. Locate the transmission oil tanks (B, Figure 33) by raising the seat plate of the unit.
2. Check the oil level when the unit is cold. The oil should be up to the "FULL COLD" mark (A) on the transmission oil tanks (B). If the oil is below this level, proceed to step #3.

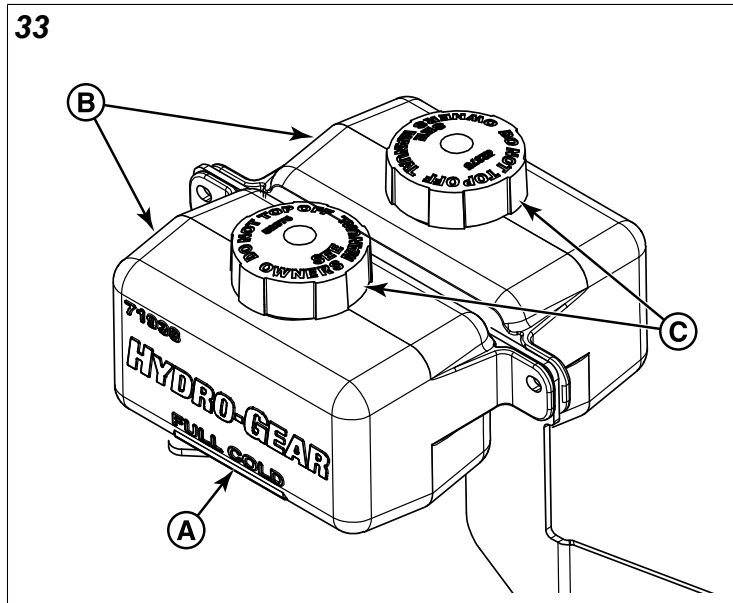

3. Before removing the tank cap (C), make sure that the area around the tank cap and fill neck of the tank is free of dust, dirt, and other debris. Remove the tank caps.
4. Add oil up to the "FULL COLD" mark.
5. Re-install the tank cap.
6. After adding oil to the tanks, it may be necessary to purge air from the hydraulic system. If the unit is not driving properly perform the *Purging the Air from the Hydraulic System* procedure.

## Transmission Oil Filter Change

**Change Interval:** Every 400 Hours or Yearly (Initial hydraulic oil and filter change after first 100 hours of operation).

**Filter Part Number:** 5104385X1

**Note:** Removing the oil filter from the transaxle will drain the oil tank. Have a suitable container ready to catch any spilled oil. The manufacturer recommends that this be a dealer-only service item.

1. Locate the hydraulic oil filter on the side of the transaxle.
2. Remove the oil filter cover (A, Figure 34) from the transaxle to drain the oil. Remove the O-ring (B) from the cover and discard the O-ring.

34

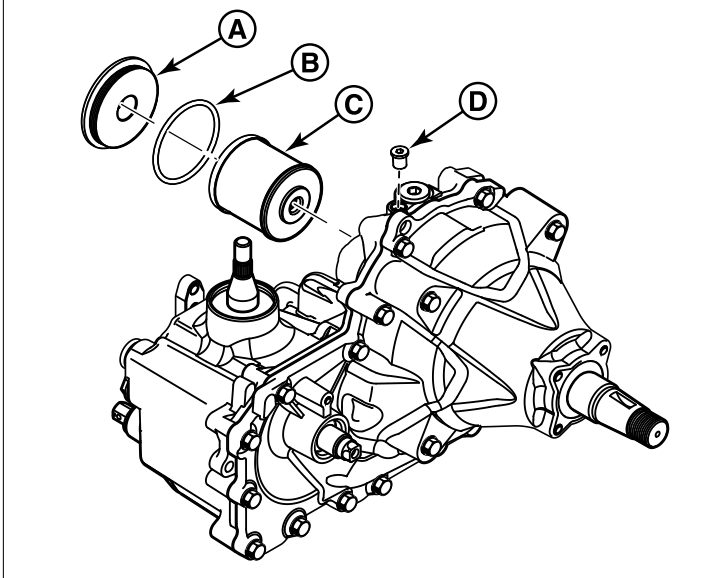

3. After the oil has drained from the transaxle, remove the oil filter (C) from the transaxle housing.
4. Install a new filter and a new O-ring onto the filter cover and install the filter cover. Torque the filter cover to 480-580 in-lbs (54.2 - 65.5 Nm).
5. Remove the top oil fill vent port (D) and fill the transaxle with new 20W50 motor oil through the expansion tank until the oil reaches the oil fill vent port.
6. Install the top oil fill vent port plug and continue filling the system with oil until the fill line is reached in the expansion tank.
7. Repeat this process for the other side of the machine.
8. Perform the *Purging the Air from the Hydraulic System* procedure.

## Purging the Air from the Hydraulic System

Due to the effects air has on efficiency in hydraulic drive systems, it is critical that it be purged from the system. These purge procedures should be implemented any time a hydraulic system has been opened to facilitate maintenance or any additional oil has been added to the system.

The resulting symptoms of air in the hydraulic system may be:

- Noisy operation.
- Lack of power or drive after short term operation.
- High operation temperature and excessive expansion of oil.

Before starting, make sure the transaxles/transmissions are at the proper oil levels. If it is not, fill to the specifications outlined in the *Check / Fill Transmission Oil Level* procedure.

### Purging Air from the Hydraulic System:

1. Chock the front wheels to prevent the machine from rolling. Raise the rear of the machine so that the vehicle's rear tires do not contact the ground. Position jack stands under the rear bumper of the machine to secure it.

2. Open the transaxle's bypass valves (see *Pushing the Rider by Hand* for the location and function of the bypass valves), start the engine, release the parking brake, and slowly move the zero-turn rider's ground speed control levers in both forward and reverse directions (5 to 6 times), as air is purged from the unit, the oil level will drop.
3. Stop the engine and engage the parking brake.
4. Close the transaxle's bypass valves, start the engine, release the parking brake, and slowly move the zero-turn rider's ground speed control levers in both forward and reverse directions (5 to 6 times), as air is purged from the unit, the oil level will drop.
5. Stop the engine. Remove the jack stands from underneath the machine.
6. Repeat the process detailed above but with the unit's drive wheels on the ground. The procedure should be performed in an area free of any objects or bystanders.

It may be necessary to repeat the process detailed above until all the air is completely purged from the system. When the transaxles/transmissions operate at normal noise levels and move smoothly forward and reverse at normal speeds, then the transaxles/transmissions are considered purged.

## Checking Tire Pressures

Tire pressure should be checked periodically, and maintained at the levels shown in the Specifications chart. Note that these pressures may differ slightly from the "Max Inflation" stamped on the side-wall of the tires. The pressures shown provide proper traction and extend tire life.

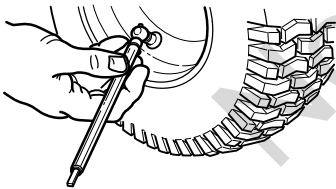

## Lubrication

Lubricate the unit at the location shown in the following figures as well as the lubrication points listed below.

### Grease:



- front caster wheel axles & yokes
- deck lift pivot blocks
- mower deck spindles
- transmission cradle pivot points

Use grease fittings when present. Disassemble parts to apply grease to moving parts when grease fittings are not installed.

Not all greases are compatible. Grease (p/n 5022285) is a Calcium Sulfonate EP NLGI #2 grease that is recommended and available through your normal parts source. Lithium Complex EP-2 NLGI #2 grease may be used if 5022285 is not available. Using a non-compatible grease could damage or cause premature parts failures.

### Oil:



- control handle pivots
- seat plate pivots
- deck lift pivots
- discharge chute hinge

Generally, all moving metal parts should be oiled where contact is made with other parts. Keep oil and grease off belts and pulleys. Remember to wipe fittings and surfaces clean both before and after lubrication.

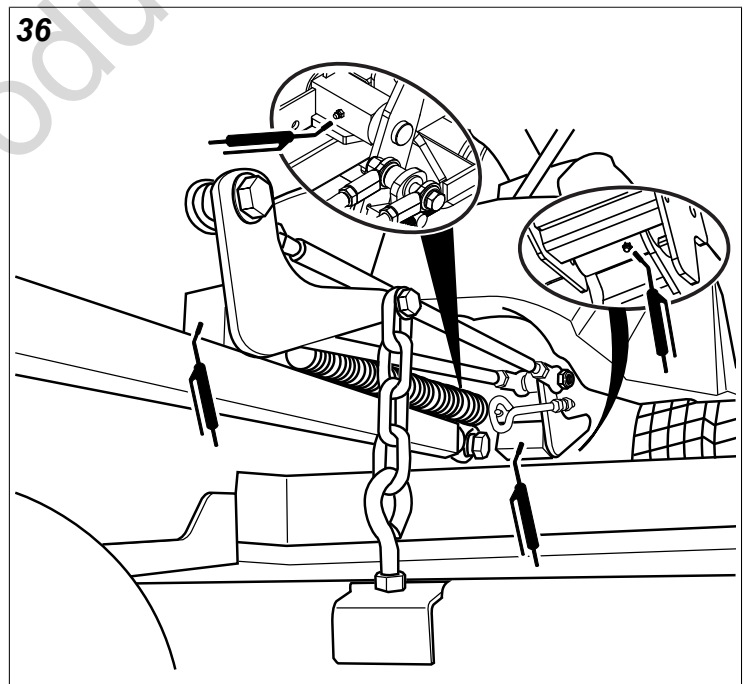
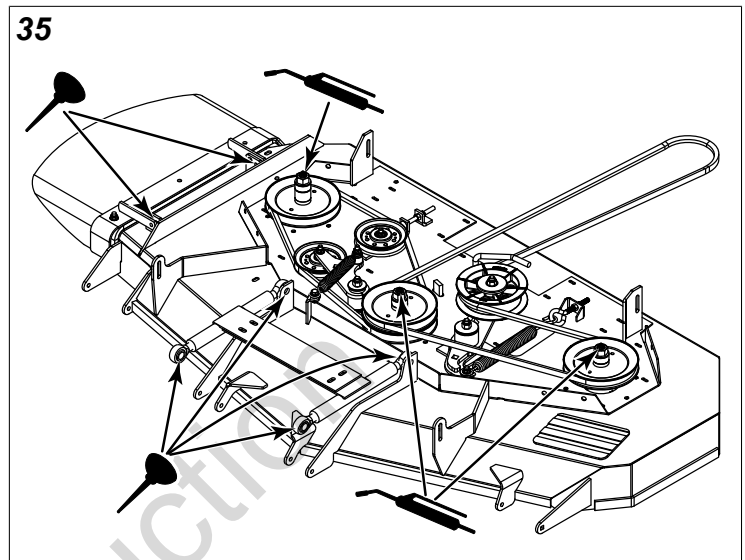

37

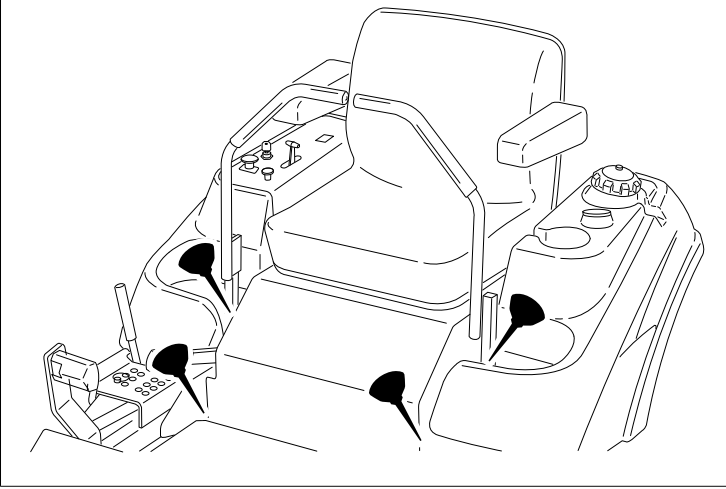

## Lubricating the ForeFront Suspension Control Arms

**Interval:** Every 50 hours.

Lubricate the ends of the four (4) ForeFront™ suspension control arms with a petroleum based chain lube at the areas identified as "A" in Figure 38.

38

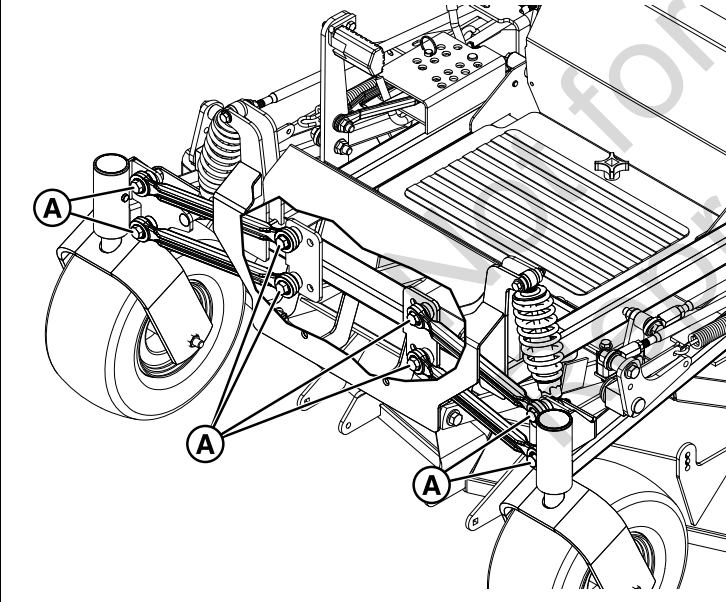

## Lubricating the Front Casters

**Interval:** Front caster wheel axles (A, Figure 39) - Every 25 hours.

**Interval:** Front caster yoke axles - Yearly.

1. Remove the 1/4-28 bolt (B, Figure 39) screwed into the caster and install a 1/4-28 grease fitting.

39

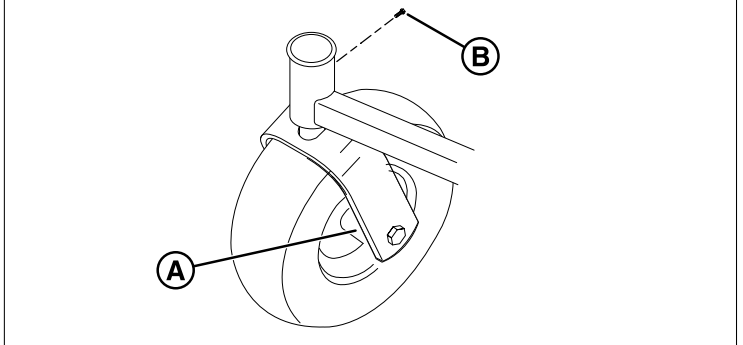

2. Grease the front caster.
3. Remove the 1/4-28 grease fitting and reinstall the 1/4-28 bolt.
4. Repeat the process for the other side of the unit.

## Servicing the Mower Blades Removing the Mower Blades



### CAUTION

**Laceration hazard**  
Mower blades are sharp.

Always wear gloves when handling, or working near, mower blades.

1. Use a block of wood to prevent the mower blade from turning as shown in Figure 40.

40



2. Using a wrench, remove the bolt securing the blade to the spindle.

## Inspecting the Mower Blades



**DANGER**  
Thrown objects hazard

Avoid injury: a worn or damaged mower blade can break and a piece of the blade could be thrown into the operator's area or bystander's area resulting in serious personal injury or death.

- Inspect the mower blade every 25 hours or at least once per year.
  - If the mower blade hits a solid object, stop the engine immediately and inspect the mower blades.
  - Never weld or straighten bent mower blades.
1. Remove the mower blade from the unit. See Removing the Mower Blades.
  2. Inspect the mower blade (Figures 41 and 42). Discard the mower blade if it has any of the following conditions:
    - More than .5" (12,7 mm) of the mower blade metal has been removed from previous sharpening or wear (A, Figure 41)
    - The air lifts are excessively eroded (A, Figure 42) and the notch (B) is .25" (6,35 mm) deep or greater.
    - The mower blade is broken or bent.

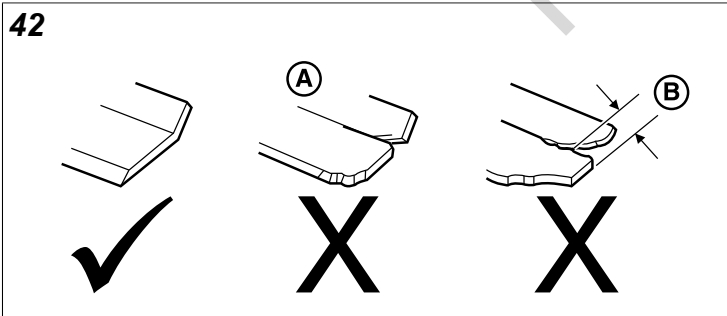
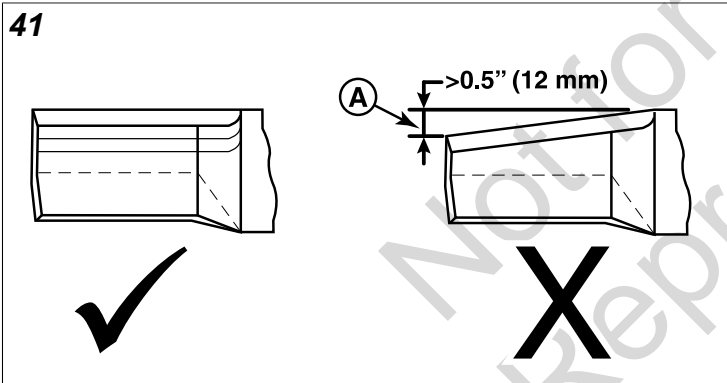

3. If the cutting edges are not sharp or have nicks, sharpen the blades. See Sharpening the Mower Blades.

## Sharpening the Mower Blades



**WARNING**  
Thrown objects and fire hazard

Grinding mower blades throws sparks and fine metal particles that are capable of igniting gasoline and gasoline vapors, and that can injure unprotected eyes.

Be sure all flammable materials are cleared from the area where grinding will occur.

Always wear safety glasses or goggles when grinding mower blades.

1. Sharpen mower blades with a grinder, hand file, or electric blade sharpener.
2. Sharpen the blade by removing an equal amount of material from the cutting edge of each end of the blade.
3. Keep the original bevel (A, Figure 43) when grinding. DO NOT change the mower blade bevel.

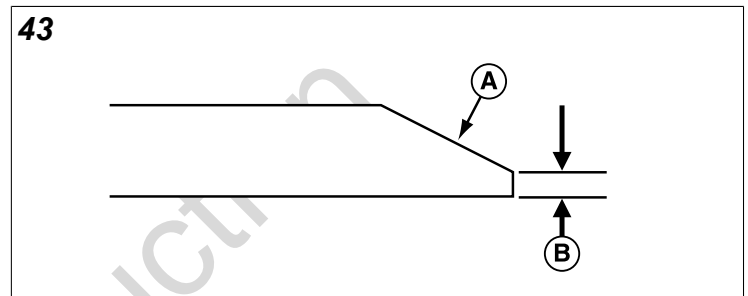

4. The mower blade should have a maximum of 1/64" (0,40 mm) cutting edge (B) or less.

## Balancing the Mower Blades



**CAUTION**  
Thrown objects hazard

An unbalanced mower blade can create excessive vibration and damage the unit, or cause mower blade failure resulting in thrown debris.

Be sure blade is balanced before installing.

1. Clean the mower blade to remove any dried grass or other debris.
2. Clamp a nail in a bench vise, hang the mower blade on the nail, and position the blade in a level horizontal position as shown in Figure 44.

44

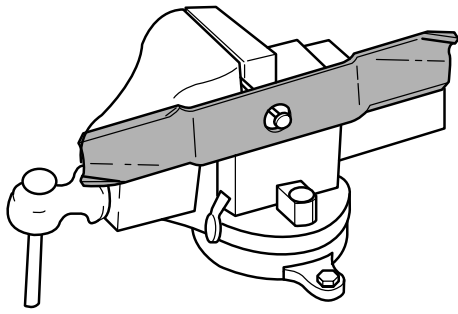

3. Check the balance of the mower blade. If either end of the mower blade moves downward is heavier than the other. Sharpen the heavy end until balance is achieved. See Sharpening the Mower Blades for sharpening instructions.
4. Repeat the process until the mower blade remains in the horizontal, level position.

### Installing the Mower Blades

1. Install each mower blade with the air lifts (C, Figure 45) pointing up towards the mower deck as shown in Figure 45 and secure with the mower blade mounting bolt (A) and flat washer (B).

45

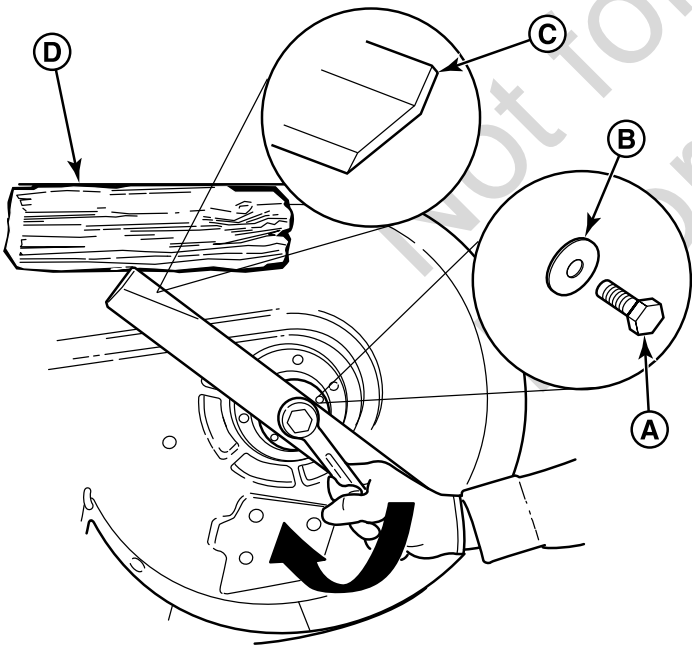

2. Wedge a wooden block (D) between the mower blade and the mower deck housing to keep the mower blade from turning and torque the blade mounting bolt to 120 ft. lbs (163 Nm).

### Seat Adjustment (Suspension Seat)

This series of mower has multiple suspension seat options: a standard suspension seat (A, Figure 46), and a suspension seat that has lumbar and back angle adjustments (B). If your

unit features a suspension seat, identify your suspension seat and follow the correct instructions below. See Figure 46.

46

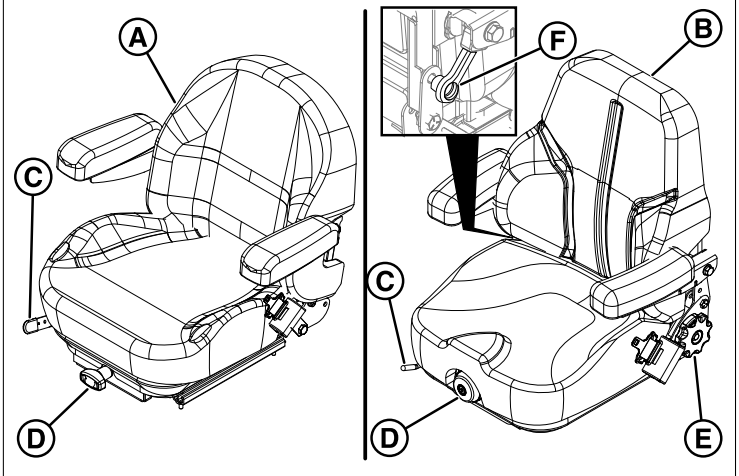

**Seat Adjustment Lever (Forwards / Backwards):** The seat can be adjusted forward and back. Move the forwards / backwards seat adjustment lever (C), position the seat as desired, and release the lever to lock the seat in position.

**Seat Adjustment Knob (Suspension/Ride Comfort):** The seat adjustment knob (D) adjusts the suspension of the seat (ride comfort). Turn the adjustment knob until the display scale has a reading that matches the weight of the operator.

**Lumbar Adjustment Knob:** Turn the lumbar adjustment knob (E) until the desired amount of lumbar is achieved.

**Back Angle Adjustment Lever:** Move the back angle adjustment lever (F), position the back angle of the seat as desired, and then release the lever.

### Ground Speed Control Lever Adjustment

The control levers can be adjusted in three ways. The alignment of the control levers, the placement of the levers (how close the ends are to one another) and the height of the levers can be adjusted.

#### To Adjust the Handle Alignment

Loosen the mount bolts (A, Figure 47) and pivot the lever(s) (C) to align with each other.

47

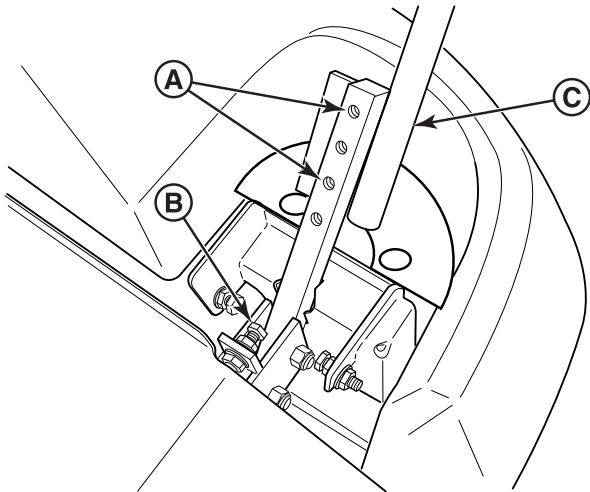

### To Adjust the Handle Placement

Loosen the jam nuts and adjust the placement bolt (B) in or out to properly adjust the lever end spacing.

### To Adjust the Handle Height

Remove the mounting hardware and reposition the handle either up or down from its original position. You will need to readjust the handle alignment as described above.

## Speed Balancing Adjustment

If the rider veers to the right or left when the ground speed control levers are in the maximum forward position, the top speed of each of these levers can be balanced by turning the adjustment bolt(s) (A, Figure 48). Only adjust the speed of the wheel that is traveling faster.

48

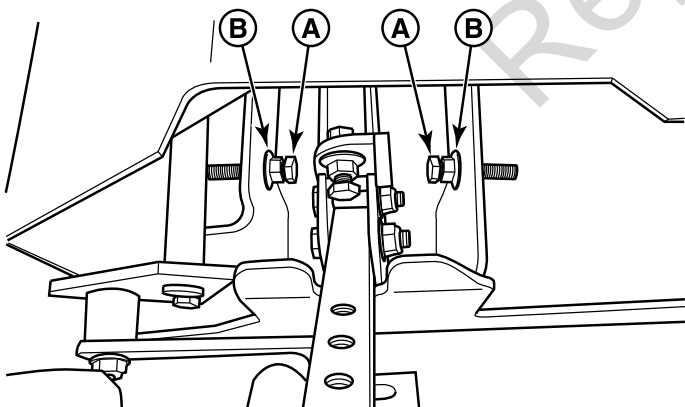

### To Reduce the Speed of the Faster Wheel

1. Loosen the securing nut (B).
2. Turn the top speed adjustment bolt **counter-clockwise** to reduce the speed.
3. Retighten the securing nut when adjustment is complete.

## ! WARNING

**DO NOT** adjust the tractor for a faster overall speed forward or reverse than it was designed for.

## Cutting Height Adjustment

The cutting height adjustment pin (A, Figure 49) controls the mower's cutting height. The cutting height is adjustable between 1-1/2" (3,8 cm) and 5" (12,7 cm) in 1/4" (0,64 cm) increments.

*Note:* Make sure that the pin is inserted into the holes in both upper and lower plates of the pin box (B).

49

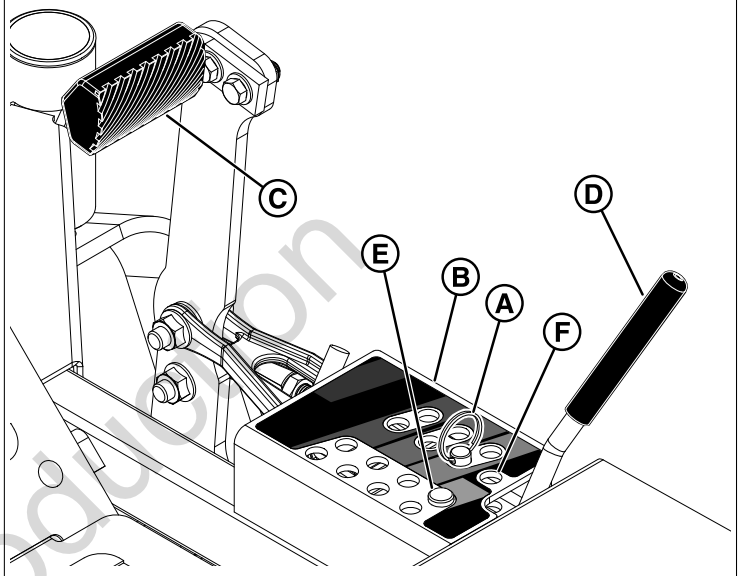

### To set the cutting height at 1-1/2" (3,37 cm):

1. While sitting in the operator's seat, press the deck lift foot pedal (C) forward until it locks into the 5" (12,7 cm) position.
2. Remove the cutting height adjustment pin from the hole that it is installed in.
3. Press the deck lift foot pedal forward and then push the lock lever (D) towards the right to release the lock.
4. Slowly release the deck lift foot pedal until it comes to rest against the stationary pin (E) in the 1-1/2" (3,37 cm) cutting height hole.
5. Place the cutting height adjustment pin in the storage hole (F).

### To set the cutting height in the range of 1-3/4" (4,40 cm) and 4-3/4" (12,06 cm):

1. While sitting in the operator's seat, press the deck lift foot pedal forward until it locks into the 5" (12,7 cm) position.
2. Place the cutting height adjustment pin in the desired cutting height.
3. Press the deck lift pedal forward and then push the lock lever towards the right to release the lock.

- Slowly release the deck lift foot pedal until it comes to rest against the cutting height adjustment pin.

**To set the cutting height at 5" (12,7 cm):**

- While sitting in the operator's seat, press the deck lift foot pedal forward until it locks into the 5" (12,7 cm) position.
- Place the cutting height adjustment pin in any open cutting height hole. The lift lock lever holds the mower deck at 5" (12,7 cm) while cutting.

## Foot Pedal Adjustment

The deck lift foot pedal can be adjusted to accommodate the operator's height for optimal comfort.

**To adjust pedal position:**

- Remove the foot pedal (A, Figure 50) from the pedal mount tab (B).

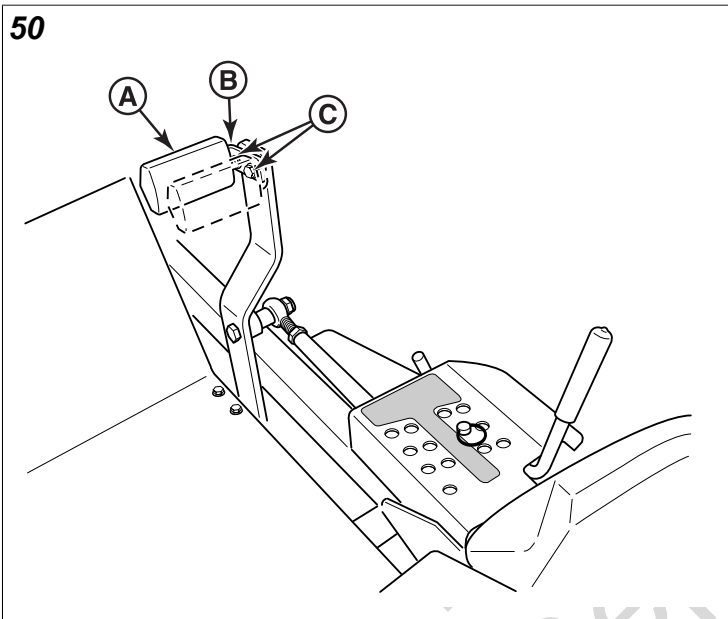

- Remove the pedal mount hardware (C) and rotate the tab 180 degrees.
- Reinstall the pedal mount hardware and tighten securely.
- Reinstall the foot pedal on the pedal mount tab in the proper orientation as shown in Figure 50.

## Floor Pan Removal & Installation

This unit is equipped with a removable floor pan which can be removed to provide better access to the mower deck.

- Loosen and remove the retaining hardware (A, Figure 51) that secures the floor pan to the frame of the unit.

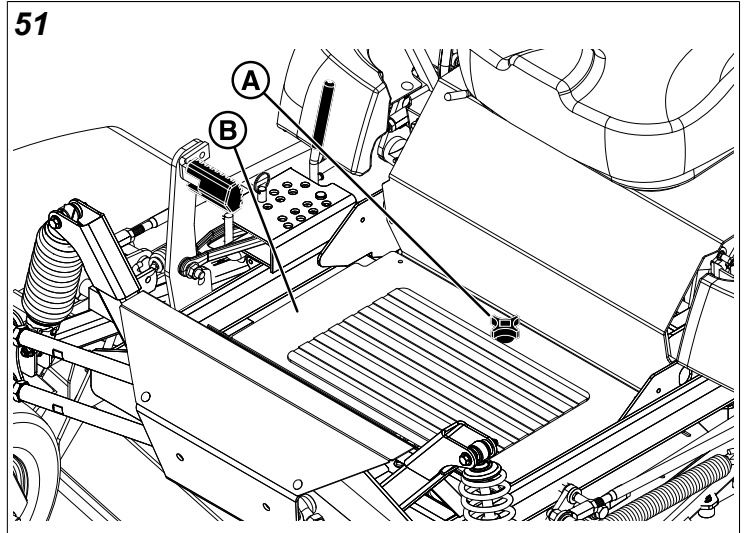

- Tilt the back end of the floor pan up and then remove it from the unit.
- To re-install the floor pan: Reverse the removal procedure.

## Neutral Adjustment

The neutral system for this mower consists of two neutral linkage rods and a pivot that connects the ground speed control lever to the transmission. The lower rod that connects the transmission to the pivot is factory preset and should not be changed for neutral adjustment purposes. The adjustment is achieved by changing the length of the upper rod (A, Figure 52) that connects the ground speed control lever to the pivot.

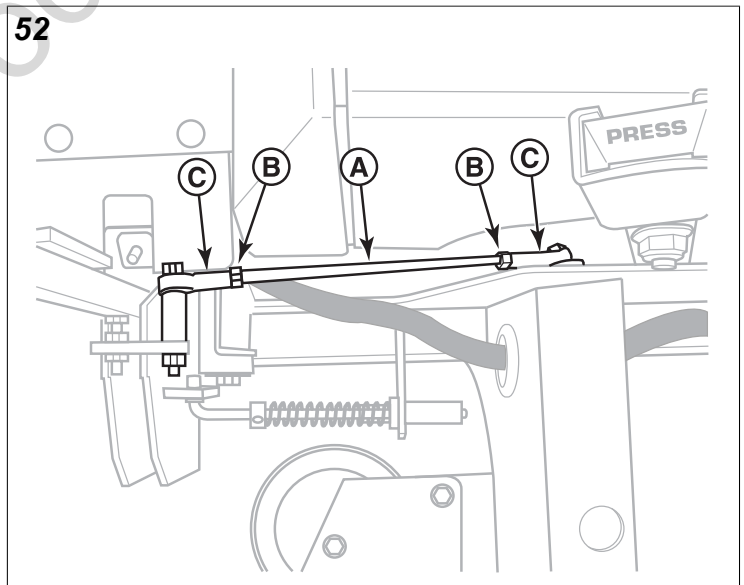

**Determining if Adjustment is Necessary:** If the tractor "creeps" while the ground speed control levers are locked in the NEUTRAL, then it may be necessary to adjust the linkage rods.

*Note:* Perform this adjustment on a hard, level surface such as a concrete floor.

- Disengage the PTO, engage the parking brake and turn off the engine.

2. There are two nuts (B) on the linkage rod. Loosen the nuts from the ball joints (C) and turn the linkage rod to adjust.
  - If the machine creeps forward, turn the rod **clockwise** (while standing at the rear of the machine, facing forward);
  - If the machine creeps backward, turn the rod **counter-clockwise** (while standing at the rear of the machine, facing forward).
3. Lock the jam nut against the ball joints when neutral is achieved.

*Note:* This adjustment should not be performed while the machine is running. It may take several attempts to achieve neutral, depending on how much the machine creeps.

## Return-to-Neutral Adjustment

Prior to performing this procedure the Neutral Adjustment Procedure must be completed.



### WARNING

To avoid serious injury, perform adjustments only with engine stopped, key removed, and tractor parked on level ground.

1. Position the ground speed control levers into the NEUTRAL LOCKOUT position
2. Loosen the set collar (A, Figure 53) on the neutral return rod (B).

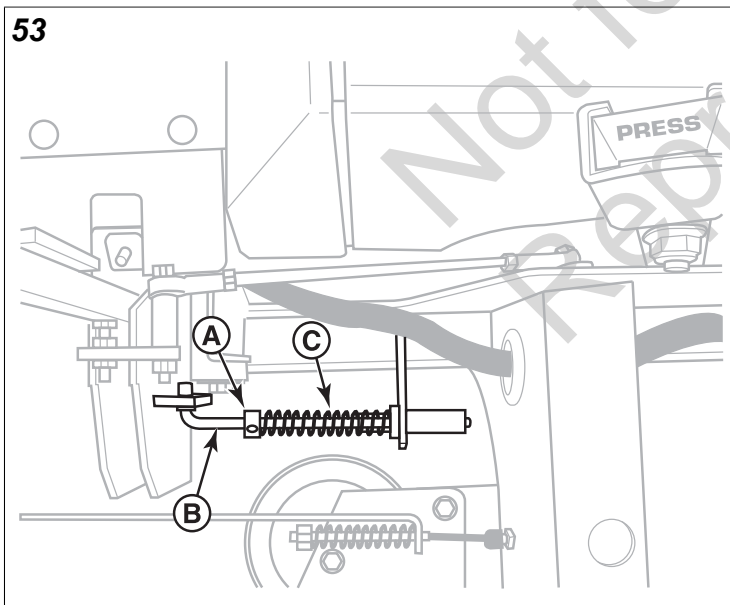

3. Position the set collar along the neutral return rod until it contacts and very lightly compresses the neutral return spring (C).
4. Move the ground speed control levers into the operating position, pull rearward, and release.
5. Move the ground speed control levers out towards the NEUTRAL LOCKOUT position.

- if the ground speed control lever aligns with the notch in the neutral lock plate, adjustment is complete;
- if the ground speed control lever stops its return motion past the notch (while standing at the rear of the machine), re-position the set collar so the neutral return spring is less compressed.
- if the ground speed control lever stops its return motion before the notch (while standing at the rear of the machine), re-position the set collar so that the neutral return spring is more compressed.

6. Repeat the process as necessary until the ground speed control lever aligns with the notch in the neutral lock plate.

*Note:* It is important to note that after every adjustment of the neutral return rod, the lever must be pulled rearward and released to properly check the return-to-neutral position.

## Neutral Lockout Adjustment

Prior to adjusting the neutral lockout, the neutral and return-to-neutral must be properly adjusted.

1. Park the unit on a flat, level surface such as a concrete floor. Disengage the PTO, engage the parking brake, turn the ignition switch to OFF, and remove the ignition key.
2. Chock the wheels of the unit to prevent movement.
3. Raise the seat to gain access to the neutral lockout components.
4. Loosen the jam nuts (A, Figure 54) on the neutral lockout bolts (B).

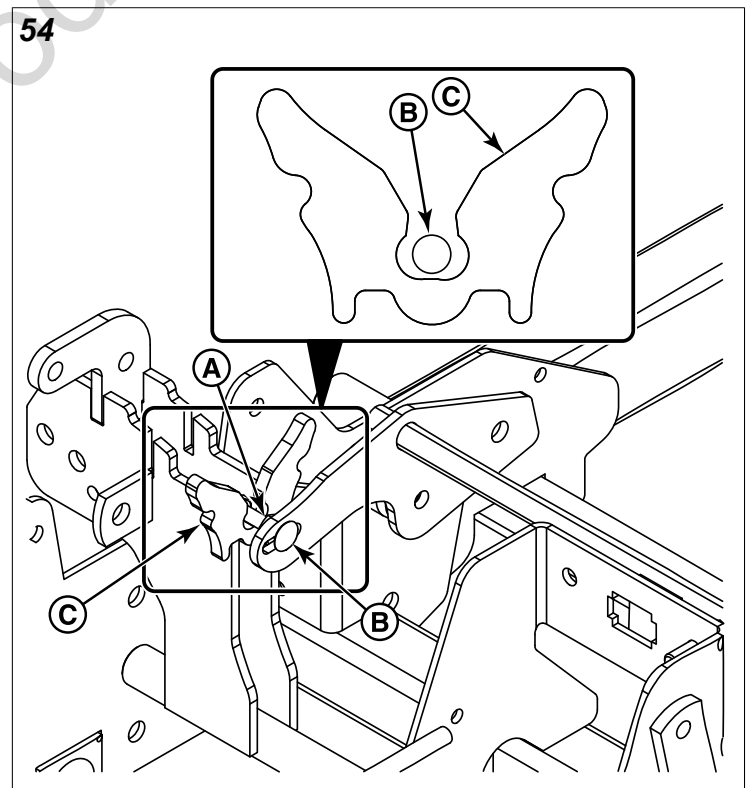

5. Engage the parking brake. The neutral lockout bolts will enter the notches of the neutral lockout plates (C).



- Position the neutral lockout bolts to the center of the notches of the neutral lockout plates.
- Re-tighten the jam nuts.

## Parking Brake Adjustment

The parking brake mechanism consists of two parking brake cables (A, Figure 55) that connect the parking brake cable shaft to the parking brake control arms on the transmissions. There is a parking brake spring (B) on each park brake cable located underneath the seat plate and connected to the parking brake shaft. The position of the of the parking brake cables in the transmission cradle and the frame of the unit is factory preset and should not be changed for parking brake adjustment procedures. The adjustment is achieved by changing the compressed spring length of the parking brake springs.

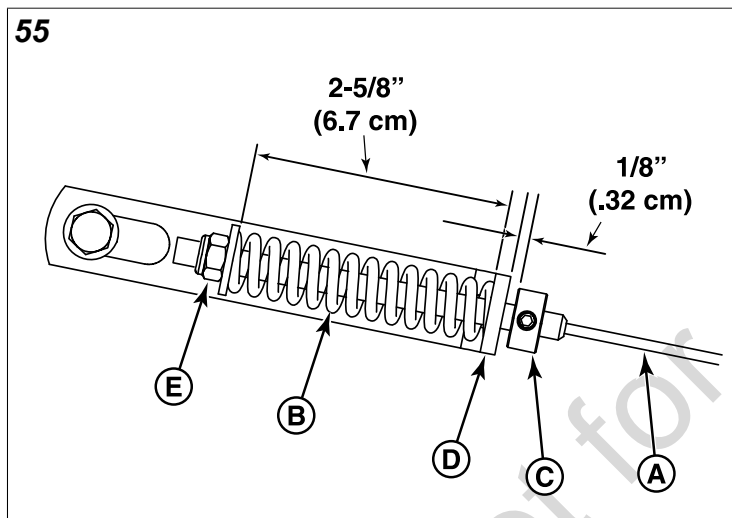

- Disengage the PTO, engage the parking brake, stop the engine, and chock the tires.
- Locate the parking brake springs located underneath the seat plate of the machine.
- With the parking brake engaged measure the compressed spring lengths. Both springs should measure 2-5/8" (6.7 cm) when compressed.
- If the length of the springs does not equal 2-5/8" (6.7 cm), the length of the springs will need to be adjusted.
- Disengage the parking brake.
- Loosen the set collars (C) and slide them away from the backs of the parking brake spring brackets (D).



### CAUTION

Do not adjust the springs to be shorter than 2-3/8" (6.03 cm) when compressed. This may damage the spring mechanism.

- Turn the adjustment nuts (E) to compress or release the spring.
- Engage the parking brake and re-measure the springs. Continue this process until the compressed length of the each spring measures 2-5/8" (6.7 cm).

- Position the set collars 1/8" (.32 cm) away from the parking brake spring brackets and tighten.

If this does not correct the braking problem, see your dealer.

## Deck Lift Rod Timing Adjustment

### Checking the Deck Lift Rod Timing

- Park machine on a flat, level surface. Disengage the PTO, stop the engine, and engage the parking brake. Verify the tires are inflated to the correct pressure.
- To check the inner lift rod (A, Figure 56) timing, measure and record the distance between the inner lift pivots (B) and the inner rod pivots (C). Repeat for other side of unit.

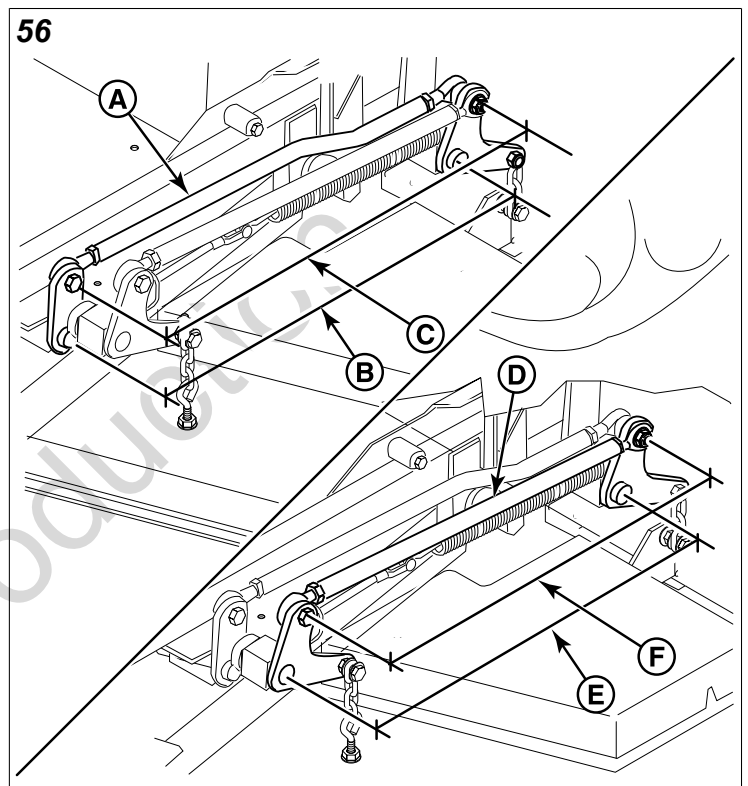

- To check the outer lift rod (D) timing, measure and record the distance between the outer lift pivots (E) and the outer rod pivots (F). Repeat for other side of unit.
- If the measurements for the inner rods are equal, and the measurements for the outer rods are equal, no further adjustment is required. If the measurements are NOT equal (greater than 1/8" (3,17 mm) difference), adjustment is required, continue with Adjusting the Deck Lift Rod Timing.

### Adjusting the Deck Lift Rod Timing

- Lock the deck lift pedal in the 5" (12,7cm) position. Remove the height adjustment pin (A, Figure 57) and lower the mower deck.

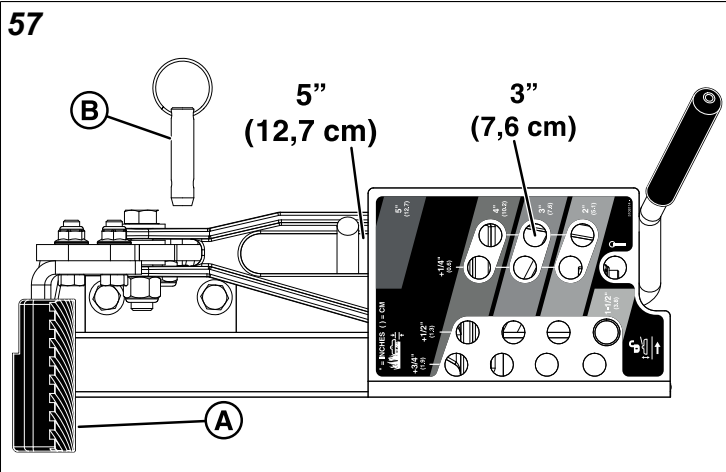

- To ensure that the deck is in the lowest position, push the pedal by hand towards the rear of the unit and install the height adjustment pin in the 3" (7.6 cm) position to hold in place.
- Block up the mower deck until all hanger chains are slack.
- To adjust the inner lift rod (A, Figure 58): Loosen the jam nut (B) on the front ball joint (C) then remove the 1/2" hardware (D) fastening the ball joint to the lift pivot arm. Turn the ball joint **clockwise** to shorten the distance between the rod pivots or **counter-clockwise** to lengthen the distance between the rod pivots. Reinstall the ball joint on the lift pivot arm and secure with the 1/2" hardware previously removed. Tighten the jam nut against the lift rod.

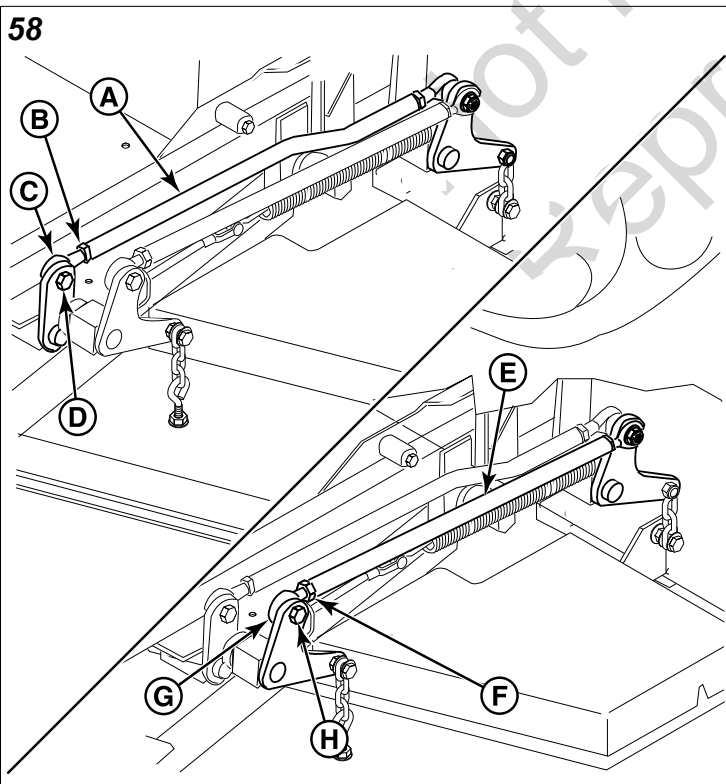

- To adjust the outer lift rod (E): Loosen the jam nut (F) on the front ball joint (G) then remove the 1/2" hardware (H) fastening the ball joint to the lift pivot arm. Turn the ball

joint **clockwise** to shorten the distance between the rod pivots or **counter-clockwise** to lengthen the distance between the rod pivots. Reinstall the ball joint on the lift pivot arm and secure with the 1/2" hardware previously removed. Tighten the jam nut against the lift rod.

- Remove blocks from under the mower deck.
- Remove the cutting height adjustment pin from in front of the deck lift pedal arm. Lift mower deck and reinstall adjustment pin in desired mowing height.

## Deck Leveling Adjustment

Before adjusting the deck level, the deck lift rod timing must be checked and/or adjusted.

### Determining if the Deck Leveling Needs to be Adjusted

- Park the unit on a flat, level surface. Disengage the PTO, engage the parking brake, turn the ignition switch to OFF, and remove the ignition key.
- Lock the deck lift pedal in the TRANSPORT position. Place the cutting height adjustment pin in the 4" position and lower the deck lift pedal until the deck lift arm contacts the cutting height adjustment pin.
- Verify that the tires are inflated to the correct pressure.
- Verify that the mower blades are flat, and not bent or broken. A bent or broken blade must be replaced.



### WARNING

**Avoid Injury! Mower blades are sharp.**

Always wear gloves when handling blades or working near blades.

- See Figure 59. Position the outside mower blades so they face front-to-back.

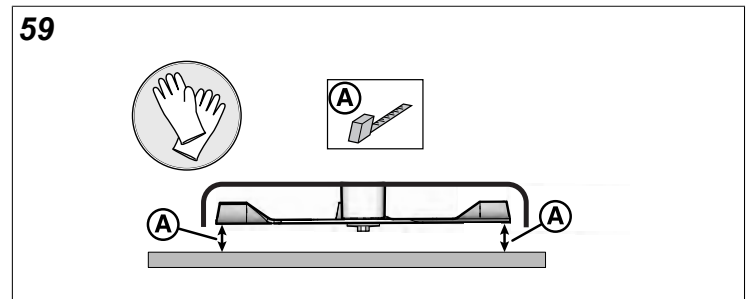

- Measure the front tip (A, Figure 59) of the blade from the cutting edge to the ground.
- Measure the rear tip (A) of the blade from the cutting edge to the ground.
- Repeat the process on the other side of the machine.
  - the front measurements should equal 4" (10,2 cm).
  - the rear measurements should equal 4-1/4" (10,8 cm)

If the measurements do not equal the measurements as listed above, adjust the deck leveling.

## Deck Leveling Procedure

This series of mower features two different front deck mounting systems depending on the serial number of the unit.

Models in serial number range 4001489241 and below feature a slot mounting system.

Models in serial number range 4001489242 and above feature a three hole mounting system.

Refer to the correct Deck Leveling Procedure section based on the serial number of your unit.

### Deck Leveling Procedure - S/N: 4001489241 and Below

1. Place the deck height adjustment pin in the 4" (10,2 cm) position.
2. Place 2 X 4 blocks (B, Figure 60) under each corner of the mower deck with the 3-1/2" sides being vertical. Place a 1/4" (0,64 cm) thick spacer (C) on the top of the rear blocks. The arrow (A) points towards the front of the mower deck.

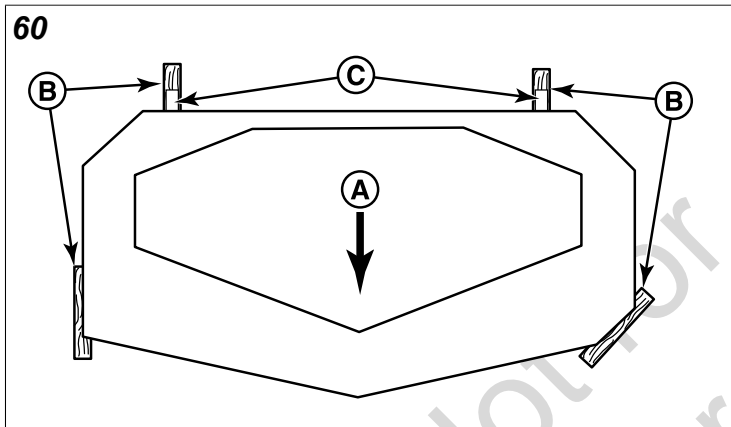

3. Loosen the nuts (D, Figure 61) and allow the front of the deck to rest on the 2 X 4's. Slide the chains in the slots until the chains are tight and tighten the nuts.

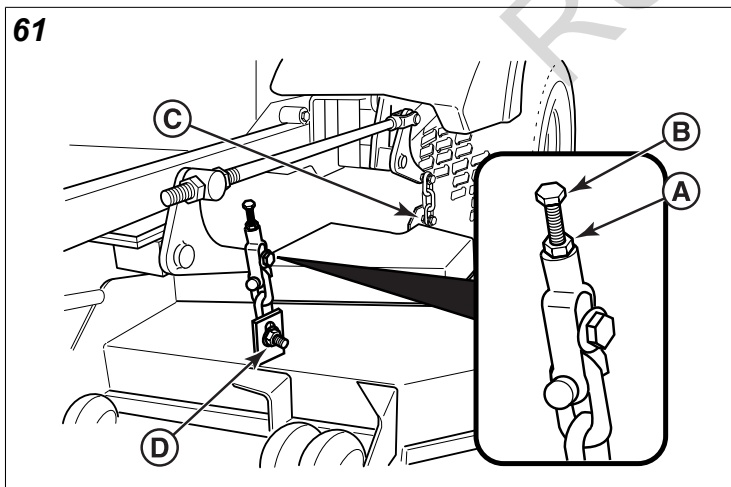

4. Loosen the nuts (C) and allow the rear of the deck to rest on the 2 X 4's and 1/4" spacers. Slide the chains in the slots until the chains are tight and tighten the nuts.
5. Repeat the process for the other side of the unit.

6. Remove all the blocks and spacers for under the mower deck.
7. Perform the *Determining if the Deck Leveling Needs to be Adjusted* procedure to verify that the deck has been leveled correctly.
  - If the mower deck does not measure 4" (10,2 cm) in the front and 4-1/4" (10,8 cm) in the rear, proceed with step #8.
8. Loosen the jam nut (A) and turn the fine adjustment bolt (B) to adjust the deck height.
  - Turn the bolt **clockwise** to raise the deck.
  - Turn the bolt **counter-clockwise** to lower the deck.
9. Once the desired measurements are achieved, tighten the jam nut.
10. Repeat the process for the other side of the unit.

### Deck Leveling Procedure - S/N 4001489242 and Above

1. Set the mower deck to the 4" (10,2 cm) cutting height position.
2. Measure from the front tips of the blades to the ground.
  - If the measurements between the front tips of the blades and the ground is greater than 4-1/4" (10,8 cm) or less than 3-3/4" (9,5 cm) the hole that the mounting hardware is in will need to be relocated.
  - If the measurements between the front tips of the blades and the ground falls between 3-3/4" (9,5 cm) and 4-1/4" (10,8 cm), skip to step #6.
3. Place blocking underneath all four corners of the mower deck until the hanger chains are slack.
4. Position the hardware (A, Figure 62) that secures the front hanger chain (B) to the front mounting plate (C).
  - If the measurement between the front tip of the blade and the ground was 4-1/4" (10,8 cm) or higher, position the hardware in the next higher hole in the front mounting plate.
  - If the measurement between the front tip of the blade and the ground was 3-3/4" (9,5 cm) or lower, position the hardware in the next higher hole in the front mounting plate.

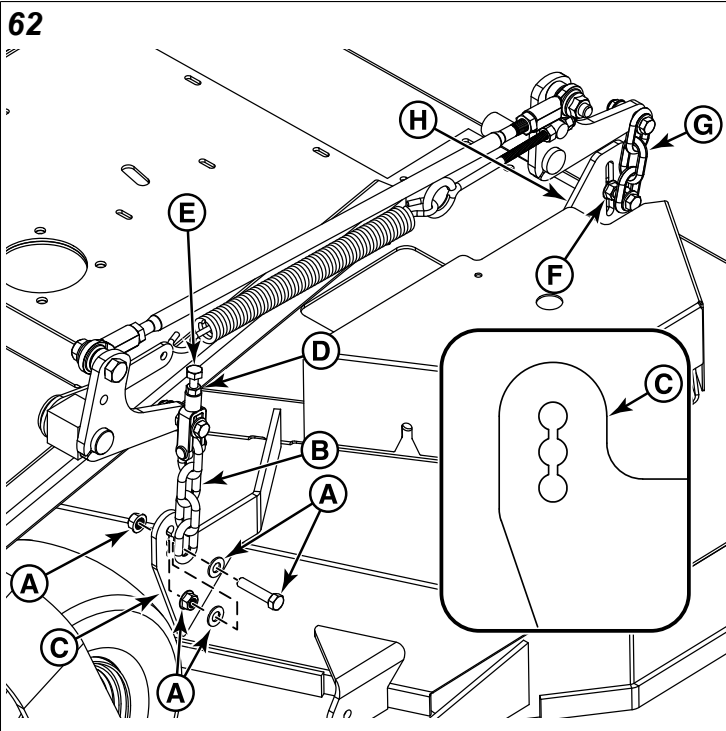

5. Repeat step #4 for the other side of the mower deck.
6. Remove the blocking from underneath the deck and replace with 2 X 4 blocks (B, Figure 63) under each corner of the mower deck with the 3-1/2" (8,9 cm) sides being vertical. Place a 1/4" (0,64 cm) thick spacer (C) on top of the rear blocks. The arrow (A) points towards the front of the mower deck.

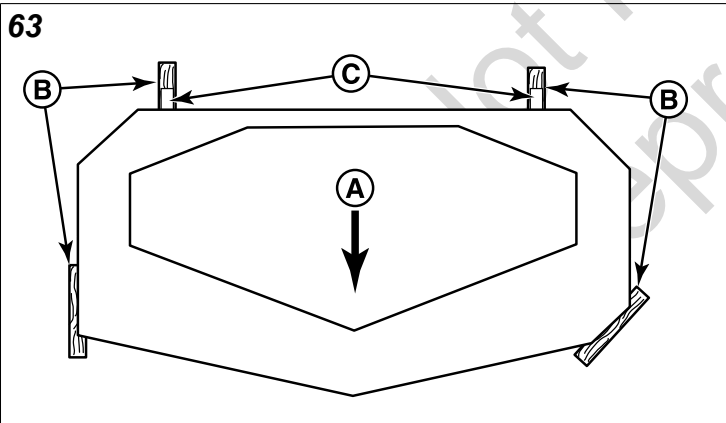

7. Check the measurements between the front tips of the mower blades and the ground.
  - If the measurements are greater than 4" (10,2 cm) loosen the jam nut (D, Figure 62) and turn the fine adjustment bolt (E) **counter-clockwise** to lower the deck.
  - If the measurements are less than 4" (10,2 cm) loosen the jam nut and turn the fine adjustment bolt **clockwise** to raise the deck.
8. Once the 4" measurement from the front tip of the blade is achieved, tighten the jam nut.

9. Loosen the nuts (F) that secure the rear hanger chain (G) to the rear mounting plate (H) and allow the rear of the deck to rest on the 2 X 4's and 1/4" (0,64 cm) spacers.
10. Repeat steps #7 - #9 for the other side of the unit.
11. Remove all blocking from beneath the mower deck.
12. Perform the **Determining if the Deck Leveling Needs to be Adjusted** procedure to verify that the deck has been leveled correctly.

## Deck Lift Assist Springs

Some models are equipped with deck lift assist springs (A, Figure 64) that assist the operator in raising the mower deck with the deck lift pedal. The deck lift assist springs are factory set to provide optimal lifting performance.

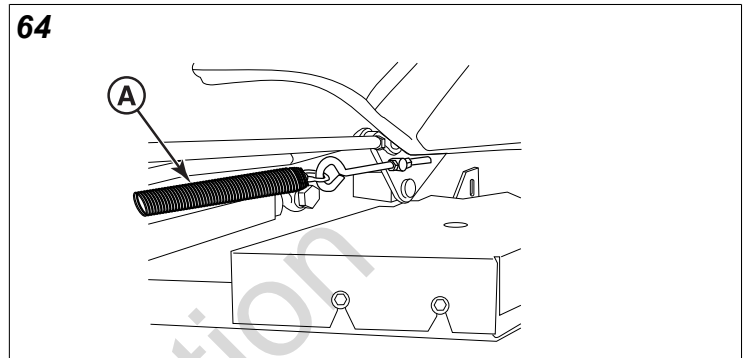

Although it is fastened with a multi-position anchor, this is **not an adjustment point**.

Do NOT attempt to adjust the spring length or lifting performance will be compromised.

## Long Left Hand Deck Belt Replacement

**NOTICE** To avoid damaging belts, do not pry over pulleys.

1. Park the unit on a smooth level surface such as a concrete floor. Disengage the PTO, engage the parking brake, turn the ignition switch to OFF, and remove the ignition key.
2. Lower the mower deck to its lowest cutting position and remove the mower deck guards and floor pan to gain access to the mower deck drive belts.



### WARNING

- Use extreme caution when rotating the idler arm with the breaker bar, due to the increased tension in the spring as the idler arm is being rotated. Injury may result if the breaker bar is prematurely released while the spring is under tension.
3. Using a 1/2" breaker bar (A, Figure 65) place the square end in the opening in the PTO clutch drive idler arm (B) and rotate the idler arm **clockwise**, which will relieve tension on the belt exerted from the idler arm. Remove the belt from the left hand side spindle pulley (C). Carefully release the tension on the breaker bar.

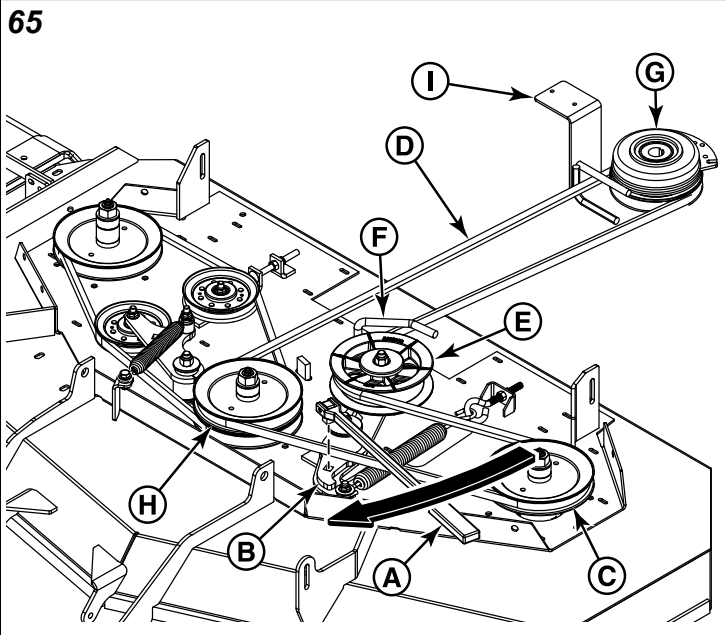

4. Remove the long left hand belt (D) from the adjustable idler pulley (E) and its belt guide (F).
5. Remove the old long left hand belt from the PTO clutch pulley (G) and the top groove of the center spindle pulley (H).
6. Install the new long left hand belt onto the PTO clutch pulley and the center spindle pulley.
7. Install the long left hand belt into the belt guide on the adjustable idler pulley.
8. Verify that the V-side of the belt runs in the pulley grooves of the center spindle pulley and the PTO clutch pulley. Make sure that the back side of the belt contacts the face of the adjustable idler pulley. Make sure that the belt is correctly routed in the belt guides (F & I).
9. Using a 1/2" breaker bar place the square end in the opening in the PTO clutch drive idler arm and rotate the idler arm **clockwise**, which will relieve tension on the belt exerted from the idler arm. Install the long left hand belt onto the left hand spindle pulley. Carefully release the tension on the breaker bar.
10. Measure the coil-to-coil length (A, Figure 66) of the long left hand belt tensioning spring (B). The measurement should equal 10-1/4" (26 cm)  $\pm$  1/8 (0,32 cm). If not, loosen the jam nut (C) on the eye bolt (D) and then turn the adjustment nut (E) until the measurement is achieved. Tighten the jam nut.

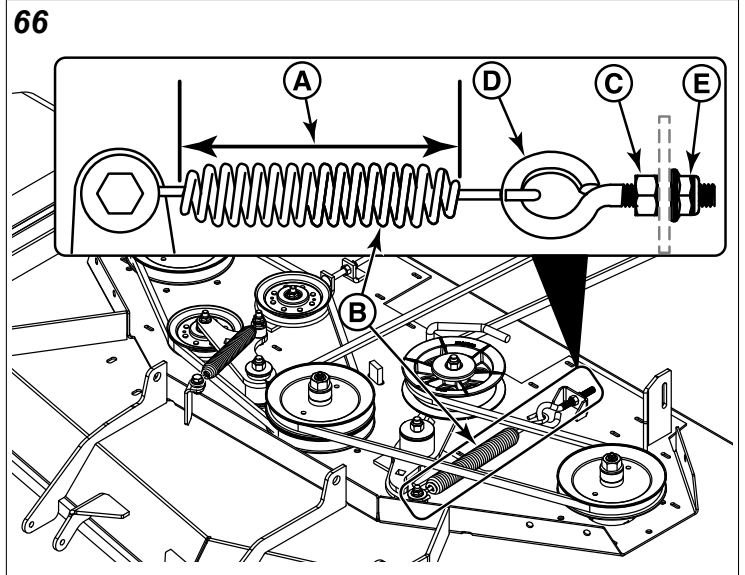

11. Re-install the mower deck guards and the floor pan.
12. Run the mower under no-load condition for about five (5) minutes to break in the new belts.

## Short Right Hand Deck Belt Replacement

**NOTICE** To avoid damaging belts, **do not pry over pulleys.**

1. Park the unit on a smooth level surface such as a concrete floor. Disengage the PTO, engage the parking brake, turn the ignition switch to OFF, and remove the ignition key.
2. Lower the mower deck to its lowest cutting position and remove the mower deck guards and floor pan to gain access to the mower deck drive belts.
3. Remove the long left hand deck belt. See *Long Left Hand Deck Belt Replacement* for removal instructions.

### **WARNING**

- Use extreme caution when rotating the idler arm, due to the increased tension in the spring as the idler arm is being rotated. Injury may result if the idler arm is prematurely released while the spring is under tension.
4. Rotate the spindle drive idler arm (A, Figure 67) **clockwise**, which will relieve the tension on the belt exerted from the idler arm. Remove the belt from the rear idler pulley (B) and then the right hand spindle pulley (C). Carefully release the tension on the spindle drive idler arm.

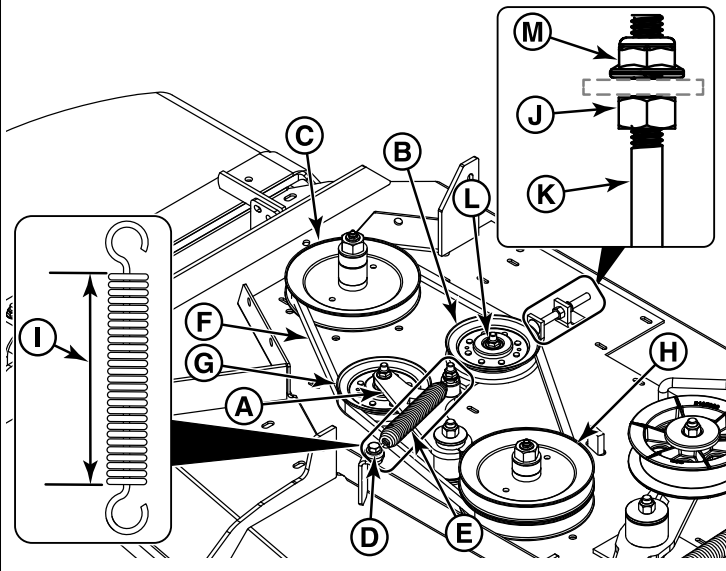

5. Remove the spring anchor hardware (D) that anchors the idler arm spring (E) to the mower deck.
6. Remove the old short right hand belt (F) from the front idler pulley (G) and the center spindle pulley (H).
7. Install the new short right hand belt onto the center spindle pulley and the front idler pulley.
8. Re-connect the idler arm spring. Install the 3/8 washer and then the spacer onto the shaft of the 3/8 bolt. Install the hook of the idler arm spring around the body of the spacer and then install the bolt into the spring anchor tab and then secure with the 3/8 nylock flange nut.
9. Rotate the spindle drive idler arm **clockwise**, which will relieve the tension on the belt exerted from the idler arm. Re-install the belt on the right hand spindle pulley and the rear idler pulley. Make sure that the V-side of the belt runs in the grooves of all four pulleys. Carefully release the tension on the spindle drive idler arm.
10. Set the mower deck to it's 3-1/2" (8,9 cm) cutting position.
11. Measure the coil-to-coil length (I) of the idler arm spring. The measurement should equal 6-1/8" (15,6 cm)  $\pm$  1/8 (0,32 cm). If not, loosen the jam nut (J) on the carriage bolt (K) and the 3/8" nut (L) that secures the rear idler pulley (B) to the deck. This will allow the rear idler pulley to move in it's adjustment slot.
12. Turn the adjustment nut (M) until the measurement is achieved. Tighten the jam nut and the 3/8" nut that secures the rear idler pulley to the deck.
13. Re-install the long left hand deck belt. See *Long Left Hand Deck Belt Replacement* for re-installation instructions.
14. Re-install the mower deck guards and the floor pan.
15. Run the mower under no-load condition for about five (5) minutes to break in the new belts.

## Transmission Drive Belt Replacement

The illustration depicts the transmission drive belt setup as seen from the top side of the unit and the arrow (A, Figure 68) indicates the front of the unit.

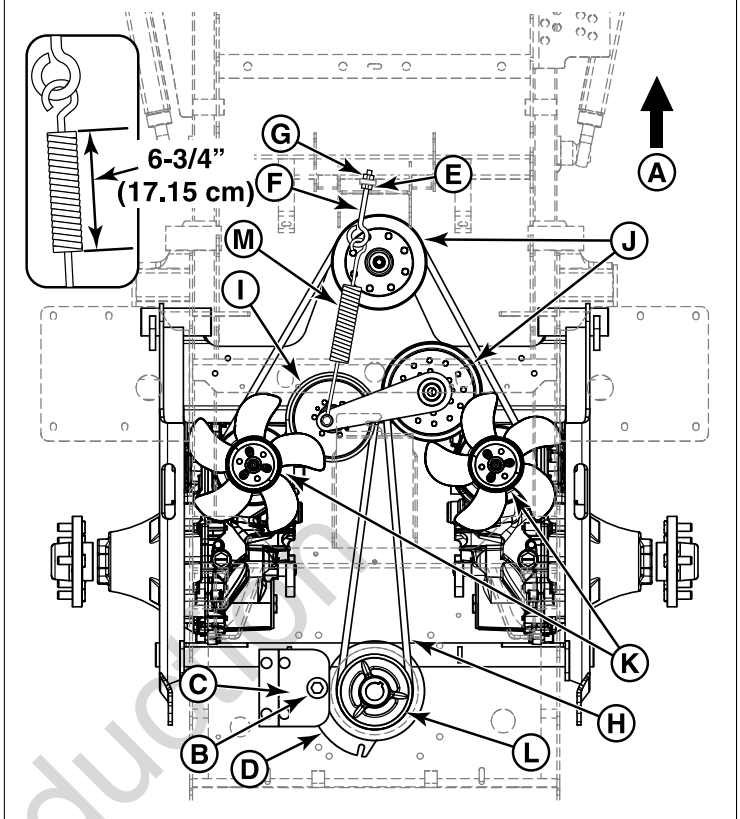

1. Park the zero-turn riding mower on a smooth, level surface such as a concrete floor. Disengage the PTO, engage the parking brake, turn off the ignition, and remove the key.
2. Remove the mower belt. See *Mower Drive Belt Replacement* for removal instructions.
3. Remove the hardware (B) that secures the clutch anchor pad (C) to the PTO clutch (D) and disconnect the wire harness from the PTO clutch.



**WARNING**  
**STORED ENERGY DEVICE:** Improper release of the belt tension spring can result in personal injury. Use extreme caution when removing the spring.

4. Loosen the jam nut (E) on the spring anchor eye bolt (F).
5. Loosen the adjustment nut (G) on the spring anchor eye bolt to release the majority of the belt tension. Use caution to remove the nut to completely release the tension.
6. Remove the old belt and replace with a new one (H). Make sure the V-side of the belt runs in the grooves of the adjustable idler pulley (I), the front stationary idler pulleys (J), both transmission pulleys (K), and the crankshaft pulley (L).

7. Re-install the spring anchor eye bolt into the spring anchor tab and loosely fasten the adjustment nut.
8. Tighten the nut until the spring (M) achieves a coil-to-coil measurement of 6-3/4" (17.15 cm).
9. Tighten the jam nut.
10. Re-install the clutch anchor pad to the PTO clutch and secure using the hardware previously removed. Reconnect the wire harness to the PTO clutch.
11. Re-install the mower belt. See *Mower Drive Belt Replacement* for re-installation instructions.

## Suspension Adjustment

The shock assemblies (A, Figure 69) can be adjusted to allow the operator to customize the ride according to the operator's weight and/or operating conditions.

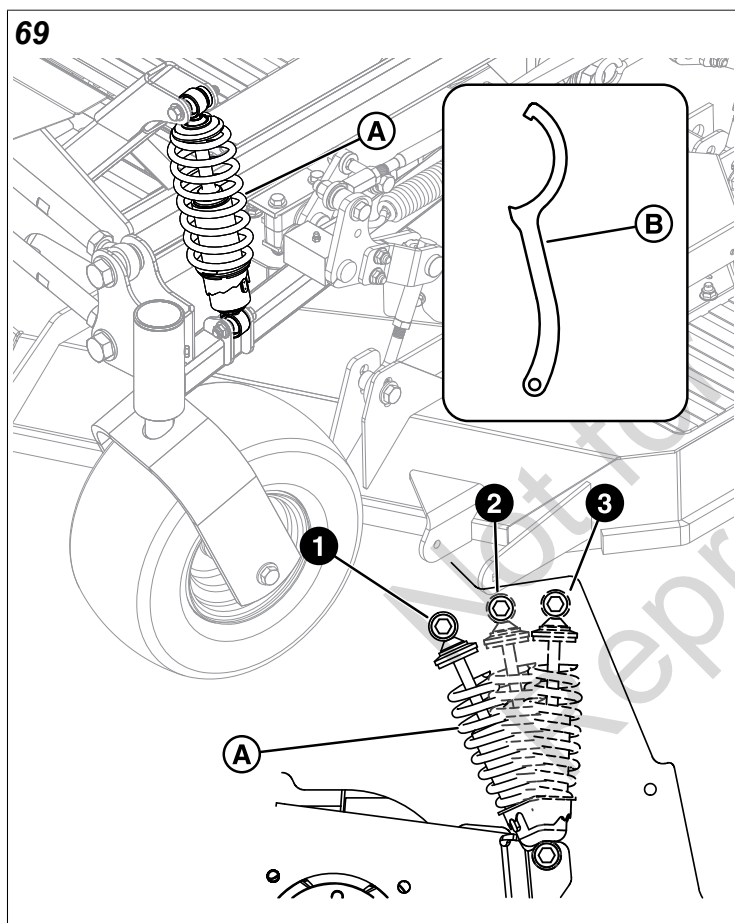

The front shock assemblies can be adjusted by changing the spring's pre-load.

The rear shock assemblies can be adjusted by changing the spring's pre-load and/or upper mounting position.

A spanner wrench (B) was included with the literature packet that came with this unit. The spanner wrench is used to adjust the spring's pre-load.

### Items to consider before adjusting the suspension:

- Less spring pre-load should be used with light weight operators, which will provide a softer, more cushioned ride.

- More spring pre-load should be used with heavy weight operator's, which will provide a stiffer, more rigid ride.
- There are three positions in which the upper shock mount can be positioned to. If adjusting the spring's pre-load does not achieve the ride requirement, the shock should be moved to the next higher numbered upper shock mounting position to achieve the desired ride requirement.
- Before adjusting the upper shock mount to a higher numbered position you should attempt to achieve the ride height through the spring's pre-load adjustment.
- Shock mounting position #3 should always be used when a rear mounted grass collection system is installed on the unit.

### To Adjust the Spring Pre-load:

This procedure details the process for adjusting the spring's pre-load for the rear shocks. **To adjust the spring's pre-load for the front shocks only steps #1 and #5 are required.**

The shock's pre-load adjustment consists of rotating the pre-load adjuster (A, Figure 70) with a spanner wrench so that the adjuster rides either up or down on the shock's fixed point (B) into one of the adjuster's five notch positions. As the adjuster moves up towards the spring, the spring is more compressed which creates more spring load. As the adjuster moves down away from the spring, the spring is less compressed creating less spring pre-load.

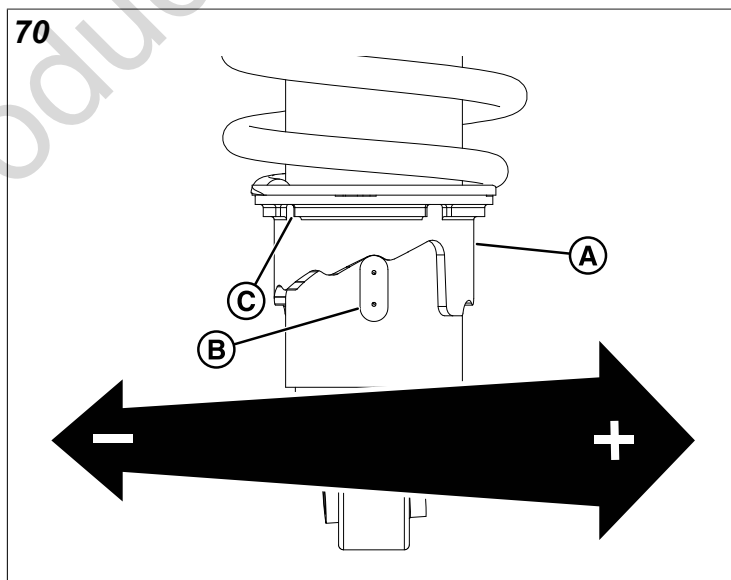

1. Park the unit on a flat, level surface such as a concrete floor. Disengage the PTO, engage the parking brake, and turn the ignition switch to OFF to stop the engine.
2. Chock the front wheels to prevent the unit from rolling.
3. Raise the rear of the unit and secure with jack stands.
4. Remove the rear drive tires.

## WARNING

Spring loaded components can kick back causing injury. Use two hands when adjusting the shock springs with the spanner wrench. This will prevent the wrench from slipping while pressure is being applied.

- Using the supplied spanner wrench (B, Figure 69), insert the tip of the wrench into the adjustment notch (C, Figure 70) in the pre-load adjuster (A). While holding the wrench in place with one hand:
  - Turn the pre-load adjuster so that it moves up towards the spring, compressing it, to increase the springs's pre-load;
  - Turn the pre-load adjuster so that it moves down away from the spring, decompressing it, to decrease the spring's pre-load.

*Note:* If necessary, a replacement spanner wrench can be ordered through your normal parts source.

- Re-install the rear drive tires. Torque the lug bolts to 85-95 ft.lbs. (115-129 Nm). Remove the jack stands from under the machine.

*Note:* If a collection system is installed on the unit it is recommended that the rear suspension be adjusted stiffer due to the added weight of the collection system.

## To Adjust the Upper Mounting Position (Rear Shocks):

- Park the unit on a flat, level surface such as a concrete floor. Disengage the PTO, engage the parking brake, and turn the ignition switch to OFF to stop the engine.
- Chock the front wheels to prevent the machine from rolling. Raise the rear of the machine and secure with jack stands. The jack stands must be under the bumper of the machine.
- Position the jack underneath the rear cross member of the transmission cradle and slowly raise the rear suspension to relieve the pressure on the upper shock mounting bolts.

*Note:* This will require small adjustments to the jack's position. The shock should move freely on the mounting bolt when the pressure is relieved.

- Remove the upper shock mounting hardware and pivot the shock to the next higher numbered position (see Figure 69). Adjust the jack to align the shock mounts to shocks.
- Remove the jack from under the transmission cradle.
- Remove the jack stands from underneath the machine.

## Battery Maintenance

This unit is equipped with a maintenance-free BCIU1 battery.

## WARNING

Keep open flames and sparks away from the battery.

- Be careful when handling the battery.
- Avoid spilling electrolyte.
- Keep flames and sparks away from the battery.
- When removing or installing battery cables, disconnect the negative cable FIRST and reconnect it LAST. If not done in this order, the positive terminal can be shorted to the frame by a tool.

## Cleaning the Battery and Cables

- Disconnect the cables from the battery, negative [-] cable first (B, Figure 71).

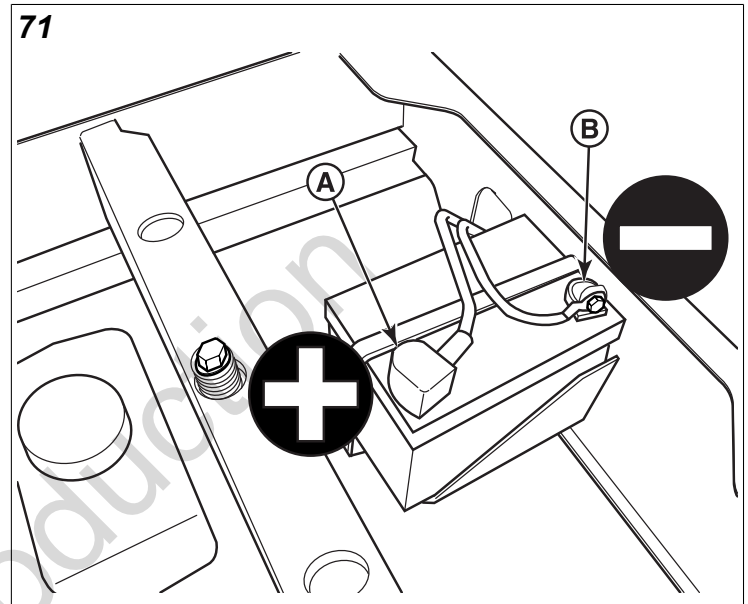

- Clean the battery terminals and cable ends with a wire brush until shiny.
- Reinstall the battery and reattach the battery cables, positive [+] cable first (A).
- Coat the cable ends and the battery terminals with petroleum jelly or non-conducting grease.

## Battery Service

### WARNING

Keep open flames and sparks away from the battery; the gasses coming from it are highly explosive. Ventilate the battery well during charging.

## Checking Battery Voltage

A voltmeter can be used to determine condition of battery. When engine is off, the voltmeter shows battery voltage, which should be 12 volts. When engine is running, the voltmeter shows voltage of charging circuit which normally is 13 to 14 volts.

A dead battery, or one too weak to start the engine, may not mean the battery needs to be replaced. For example, it may mean that the alternator is not charging the battery properly. If there is any doubt about the cause of the problem, see your



dealer. If you need to replace the battery, follow the steps under *Cleaning the Battery & Cables*.

## Charging a Completely Discharged Battery



### WARNING

- Do NOT charge battery with key switch ON.
  - Never use a quick battery charger to start engine.
  - Always disconnect negative (-) battery cable before charging battery,
1. Be aware of all the safety precautions you should observe during the charging operation. If you are unfamiliar with the use of a battery charger and hydrometer, have the battery serviced by your dealer.
  2. Add distilled water sufficient to cover the plate (fill to the proper level near the end of the charge). If the battery is extremely cold, allow it to warm before adding water because the water level will rise as it warms. Also, an extremely cold battery will not accept a normal charge until it becomes warm.
  3. Always unplug or turn the charger off before attaching or removing the clamp connections.
  4. Carefully attach the clamps to the battery in proper polarity (usually red to [+] positive and black to [-] negative).
  5. While charging, periodically measure the temperature of the electrolyte. If the temperature exceeds 125° F (51.6° C), or if violent gassing or spewing of electrolyte occurs, the charging rate must be reduced or temporarily halted to prevent battery damage.
  6. Charge the battery until fully charged (until the specific gravity of the electrolyte is 1.250 or higher and the electrolyte temperature is at least 60° F). The best method of making certain a battery is fully charged, but not over charged, is to measure the specific gravity of a cell once per hour. The battery is fully charged when the cells are gassing freely at low charging rate and less than 0.003 change in specific gravity occurs over a three hour period.

## Jump Starting With Auxiliary (Booster) Battery

Jump starting is not recommended. However, if it must be done, follow these directions. Both booster and discharged batteries should be treated carefully when using jumper cables. Follow the steps below EXACTLY, being careful not to cause sparks. Refer to Figure 72.



### WARNING

For your personal safety, use extreme care when jump starting. Never expose battery to open flame or electric spark – battery action generates hydrogen gas which is flammable and explosive. Do not allow battery acid to contact skin, eyes, fabrics, or painted surfaces. Batteries contain a sulfuric acid solution which can cause serious personal injury or property damage.

To avoid engine damage, do not disconnect battery while engine is running. Be sure terminal connections are tight before starting.

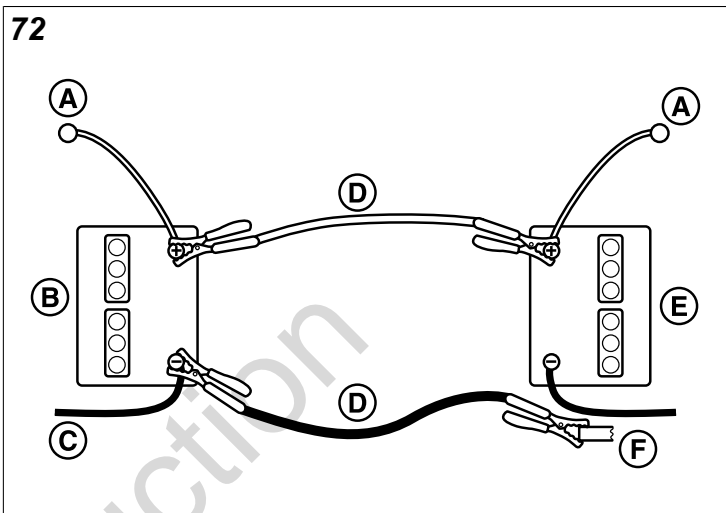

**This hook-up is for negative grounded vehicles.**

Callout	Description
A	To Starter Switch
B	Starting Vehicle Battery
C	To Ground
D	Jumper Cable
E	Discharged Vehicle Battery
F	Engine Block

**Make sure vehicles do not touch.**

1. Both batteries must be of the same voltage.
2. Position the vehicle with the booster battery adjacent to the vehicle with the discharged battery so that booster cables can be connected easily to the batteries in both vehicles. Make certain vehicles do not touch each other.
3. Wear safety glasses and shield eyes and face from batteries at all times. Be sure vent caps are tight. Place damp cloth over vent caps on both batteries.
4. Connect positive (+) cable to positive post of discharged battery (wired to starter or solenoid).
5. Connect the other end of same cable to same post marked positive (+) on booster battery.
6. Connect the second cable negative (-) to other post of booster battery.
7. Make final connection on engine block of stalled vehicle away from battery. Do not lean over batteries.

8. Start the engine of the vehicle with the booster battery. Wait a few minutes, then attempt to start the engine of the vehicle with the discharged battery.
9. If the vehicle does not start after cranking for ten (10) seconds, STOP PROCEDURE. More than ten (10) seconds seldom starts the engine unless some mechanical adjustment is made. Allow a sixty (60) second cool down period between starting attempts. Failure to follow these guidelines can burn out starter motor.
10. After starting, allow the engine to return to idle speed. Remove the cable connection at the engine or frame. Then remove the other end of the same cable from the booster battery.
11. Remove the other cable by disconnecting at the discharged battery first and then disconnect the opposite end from the booster battery.
12. Discard the damp cloths that were placed over the battery vent caps.



Any procedure other than the preceding could result in:

- (a) personal injury caused by electrolyte squirting out the battery vents,
- (b) personal injury or property damage due to battery explosion,
- (c) damage to the charging system of the booster vehicle or of the immobilized vehicle.

Do not attempt to jump start a vehicle having a frozen battery because the battery may rupture or explode. If a frozen battery is suspected, examine all fill vents on the battery. If ice can be seen or if the electrolyte fluid cannot be seen, do not attempt to start with jumper cables as long as the battery remains frozen.

## Troubleshooting

While normal care and regular maintenance will extend the life of your equipment, prolonged or constant use may eventually require that service be performed to allow it to continue to operating properly.

This troubleshooting guide lists the most common problems, their causes and remedies.

Refer to **Maintenance Procedures** for instructions on how to perform most of these minor adjustments and service repairs yourself. If you prefer, all of these procedures can be performed for you by your local authorized dealer.



Remove ignition key prior to performing maintenance on the unit.

To avoid serious injury, perform maintenance on the unit or mower deck only when the engine is stopped and the parking brake is engaged.

Always remove the ignition key, disconnect the spark plug wire(s) and fasten it away from the plug(s) before beginning the maintenance, to prevent accidental starting of the engine.

## Troubleshooting Charts

### Troubleshooting the Zero-Turn Rider

<b>Problem: Engine will not turnover or start.</b>	
<b>Cause</b>	<b>Remedy</b>
Parking brake not engaged.	Engage parking brake.
PTO (electric clutch) switch in ON position.	Place in OFF position.
Ground speed control levers not in "NEUTRAL" position.	Move ground speed control levers to the "NEUTRAL" position.
Out of fuel.	If engine is hot, allow it to cool, then refill the fuel tank.
Engine flooded.	<b>Carburated Models:</b> Move choke control to closed position. <b>Fuel Injected Models:</b> See authorized dealer.
Fuse blown.	Replace fuse.
Battery terminals require cleaning.	Clean the battery terminals.
Battery discharged or dead.	Recharge or replace
Wiring loose or broken.	Visually check wiring & replace broken or frayed wires. Tighten loose connections.
Solenoid or starter motor faulty.	See authorized service dealer.
Safety interlock switch faulty	Replace as needed. See authorized service dealer.
Spark plug(s) faulty, fouled or incorrectly gapped.	Clean and gap or replace. See engine manual.
Water in fuel.	Drain fuel and replace with fresh fuel.
Gas is old or stale.	Drain fuel and replace with fresh fuel.
<b>Fuel Injected Models:</b> Malfunction in fuel injection system.	See authorized service dealer.

<b>Problem: Engine starts hard or runs poorly.</b>	
<b>Cause</b>	<b>Remedy</b>
Fuel mixture too rich.	1.) Clean air filter. 2.) <b>Carburated Models:</b> Check choke adjustment. <b>Fuel Injected Models:</b> See authorized dealer.
Spark plug(s) faulty, fouled or incorrectly gapped.	Clean and gap or replace. See engine manual.

<b>Problem: Engine knocks.</b>	
<b>Cause</b>	<b>Remedy</b>
Low oil level.	Check / Add oil as required.
Using wrong grade oil.	See engine manual.

<b>Problem: Excessive oil consumption.</b>	
Cause	Remedy
Engine running too hot.	Clean engine fins, blower screen, and air cleaner.
Using wrong weight oil.	See engine manual.
Too much oil in crankcase.	Drain excess oil

<b>Problem: Engine exhaust is black.</b>	
Cause	Remedy
Dirty air filter.	Replace air filter. See engine manual.
<b>Carbureted Models:</b> Engine choke control is in closed position.	Move choke control to open position.

<b>Problem: Malfunction Indicator Lamp (M.I.L.) is flashing (Fuel Injected Models only).</b>	
Cause	Remedy
Problem with the fuel injection system.	See your authorized service dealer.

<b>Problem: Engine runs but mower will not drive.</b>	
Cause	Remedy
Transmissions are not engaged.	Engage the transmissions. See <i>Pushing the Rider by Hand</i> .
Belt is broken.	See <i>Transmission Drive Belt Replacement</i> .
Drive belt slips.	See problem and cause below.
Brake is not fully released.	See authorized service dealer.

<b>Problem: Unit drive belt slips.</b>	
Cause	Remedy
Pulleys or belt greasy or oily.	Clean as required.
Tension too loose	Adjust spring tension. See <i>Transmission Drive Belt Replacement</i> .
Belt stretched or worn	Replace belt.

<b>Problem: Brake will not hold.</b>	
Cause	Remedy
Brake is incorrectly adjusted.	See <i>Parking Brake Adjustment</i> .
Braking pads in transmissions worn.	See authorized dealer.

<b>Problem: Unit steers or handles poorly.</b>	
Cause	Remedy
Steering linkage is loose.	Check and tighten any loose connections.
Improper tire inflation	See <i>Checking Tire Pressures</i> .

## Troubleshooting the Mower

<b>Problem: Mower will not raise.</b>	
Cause	Remedy
Lift linkage not properly attached or damaged.	See authorized dealer.

<b>Problem: Engine stalls easily with mower engaged.</b>	
Cause	Remedy
Engine speed too slow.	Set to full throttle.
Ground speed too fast.	Decrease ground speed.

<b>Problem: Engine stalls easily with mower engaged.</b>	
Cutting height set too low.	Increase the cutting height.
Discharge chute jamming with cut grass.	Cut grass with discharge pointing towards previously cut area.

<b>Problem: Excessive mower vibration.</b>	
Cause	Remedy
Blade mounting bolts are loose.	Tighten to 120 ft.lbs (163 Nm).
Mower blades, arbors, or pulleys are bent.	Check and replace as necessary.
Mower blades are out of balance.	Remove, sharpen, and balance blades. See <i>Servicing the Mower Blades</i> .
Belt installed incorrectly.	Reinstall belt correctly.

<b>Problem: Excessive belt wear or breakage.</b>	
Cause	Remedy
Bent or rough pulleys.	Repair or replace.
Using incorrect belt.	Replace with correct belt.
Incorrect belt tension.	Adjust to correct tension.

<b>Problem: Drive belt slips or fails to drive.</b>	
Cause	Remedy
Incorrect belt tension.	Adjust to correct tension.
Drive belt is broken.	Replace with new belt.

<b>Problem: Mower does not engage.</b>	
Cause	Remedy
Electrical wiring damage.	Locate & repair damaged wire.
Battery voltage too low.	Recharge battery and check alternator. See <i>Battery Service</i> .

## Troubleshooting Common Cutting Problems

<b>Problem: Striking</b>	
Striking is when thin strips of uncut grass are left behind the mower. Striking is usually caused by operator error or poor blade maintenance.	

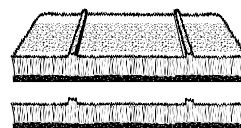

Cause	Remedy
Blades are not sharp.	Sharpen your blades.
Blades are worn down too far.	Replace your blades.
Engine speed is too slow.	Always mow at full throttle.
Ground speed is too fast.	Slow down.
Deck is plugged with grass.	Clean out the mower.
Not overlapping cutting rows enough.	Overlap your cutting rows
Not overlapping enough when turning.	When turning your effective cutting width decreases—overlap more when turning.

<b>Problem: Scalping</b>	
Scalping is when the mower deck comes close to or hits the ground. Scalping can be caused by the mower deck misadjustment, unevenness in the lawn, or by mower deck bouncing because the ground speed is too fast.	

### Problem: Scalping

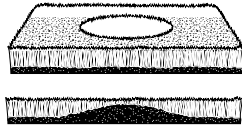

Cause	Remedy
Lawn is uneven or bumpy.	Roll or level the lawn.
Mower deck cutting height is set too low.	Raise the cutting height.
Ground speed is too fast.	Slow down.
Deck is not leveled correctly.	Correctly level the deck.
Tire pressure is low or uneven.	Check and inflate the tires.

### Problem: Stepped Cutting

Stepped cutting is sharp ridges or uneven levels left in the lawn surface. Stepped cutting is usually caused by mower deck damage or misadjustment, or damage to the mower blades.

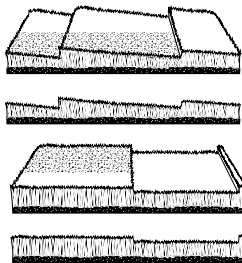

Cause	Remedy
Deck is not leveled correctly.	Level the deck correctly.
Tires are not properly inflated.	Check and inflate the tires.
Blades are damaged.	Replace the blades.
Deck shell is damaged.	Repair or replace the deck.
Mower spindle is bent or loose.	Repair or replace the spindle.
Blades are installed incorrectly.	Reinstall the blades correctly.

### Problem: Uneven Cutting

Uneven cutting is waviness or smooth troughs in the lawn surface. Uneven cutting is usually caused by mower deck damage or misadjustment.

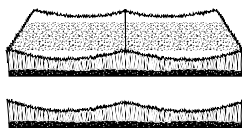

Cause	Remedy
Deck is not leveled correctly.	Level the deck correctly.
Blades are dull or worn.	Sharpen or replace the blades.
Blades are damaged.	Replace the blades.
Deck is clogged with grass clippings.	Clean out the deck.
Deck shell is damaged.	Repair or replace the deck.
Mower spindle is bent or loose.	Repair or replace the spindle.
Blades are installed incorrectly.	Reinstall the blades correctly.
Tires are not properly inflated.	Check and inflate the tires.

### Problem: Stringers

Stringers are sparse patches of uncut grass left behind the mower. Stringers are usually caused by operator error or poor blade maintenance.

### Problem: Stringers

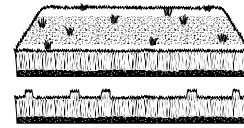

Cause	Remedy
Blades are not sharp or nicked.	Sharpen your blades.
Blades are worn down too far.	Replace your blades.
Engine speed is too slow.	Always mow at full throttle.
Ground speed is too fast.	Slow down.
Deck is plugged with grass.	Clean out the mower.

## Specifications

Specifications are correct at time of printing and are subject to change without notice.

### ENGINE

For complete engine specifications see the engine manufacturer's operator's manual included with your unit.

Fits models: 5901843, 5901845, 5901846, 5901847, 5901875, 5901877, 5901923, 5901924 & 5901927

#### Briggs & Stratton Vanguard EFI

<b>Make</b>	Briggs & Stratton
<b>Model</b>	49E877-0009-G1
<b>Electrical System</b>	12 volt, 20 amp alternator, Battery: 340 cca

Fits models: 5901977, 5901978, 5902025 & 5902026

#### Kawasaki FX801V

<b>Make</b>	Kawasaki
<b>Model</b>	FX801V
<b>Electrical System</b>	12 volt, 15 amp charging coil; Battery: 340 cca

Fits models: 5901995, 5901996 & 5902028

#### Kawasaki Fuel Injected FT730V

<b>Make</b>	Kawasaki
<b>Model</b>	FT730V-AS02-S
<b>Electrical System</b>	12 volt, 30 amp charging coil; Battery: 340 cca

### CHASSIS

<b>Fuel Tank Capacity</b>	11 gallons (41,6 L) total
<b>Rear Wheels</b>	
Tire Size (Models with 52" Decks)	24 X 9.5 -12
Tire Size (Models with 61" Decks)	24 X 12.00 - 12
Inflation Pressure	15 psi (1,03 bar)
<b>Front Wheels</b>	
Tire Size	13 X 6.5 - 6
Inflation Pressure	25 psi (1,72 bar)

### TRANSMISSIONS

<b>Make</b>	Hydro-Gear®
-------------	-------------

<b>Model (Models with 52" Decks)</b>	1710-1024L (LH)
	1710-1024R (RH)
<b>Model (Models with 61" Decks)</b>	1710-1057L (LH)
	1710-1057R (RH)
<b>Type</b>	ZT-4400 Transaxles
<b>Hydraulic Fluid</b>	SAE 20W-50 motor oil
<b>Speeds</b>	Forward: 0-10 MPH (0-16.09 km/h)
	Reverse: 0-5 MPH (0-8.05 km/h)

## DIMENSIONS

<b>Models with 52" Mower Decks</b>	
<b>Overall Length</b>	83-5/8" (212 cm)
<b>Overall Width (with discharge chute up)</b>	57" (145 cm)
<b>Overall Width (with discharge chute down)</b>	67" (170 cm)
<b>Height</b>	72" (183 cm)
<b>Weight (approximate)</b>	1319 lbs (598 kg)

<b>Models with 61" Mower Decks</b>	
<b>Overall Length</b>	83-5/8" (212 cm)
<b>Overall Width (with discharge chute up)</b>	61-1/2" (156 cm)
<b>Overall Width (with discharge chute down)</b>	78" (198 cm)
<b>Height</b>	72" (183 cm)
<b>Weight (approximate)</b>	1398 lbs (634 kg)

## Warranty

If your unit is equipped with a dual function hour meter that displays both engine hours and PTO hours, the warranty is based on the engine hours as displayed by the hour meter.

## Warranty Statement

**BRIGGS & STRATTON WARRANTY POLICY (January 2014)**

### LIMITED WARRANTY

Briggs & Stratton warrants that, during the warranty period specified below, it will repair or replace, free of charge, any part that is defective in material or workmanship or both. Transportation charges on product submitted for repair or replacement under this warranty must be borne by purchaser. This warranty is effective for and is subject to the time periods and conditions stated below. For warranty service, find the nearest Authorized Service Dealer in our dealer locator map at [ferrismowers.com](http://ferrismowers.com). The purchaser must contact the Authorized Service Dealer, and then make the product available to the Authorized Service Dealer for inspection and testing.

**There is no other express warranty. Implied warranties, including those of merchantability and fitness for a particular purpose, are limited to the warranty period listed below, or to the extent permitted by law. Liability for incidental or consequential damages are excluded to the extent exclusion is permitted by law.** Some states or countries do not allow limitations on how long an implied

warranty lasts, and some states or countries do not allow the exclusion or limitation of incidental or consequential damages, so the above limitation and exclusion may not apply to you. This warranty gives you specific legal rights and you may also have other rights which vary from state to state or country to country.\*\*

<b>WARRANTY PERIOD</b>		
<b>Covered Parts</b>	<b>Standard Warranty Period</b>	<b>Rental Warranty Period</b>
Riding mowers - except as noted below +	4 years (48 months) or 500 hours, whichever occurs first. Unlimited hours during the first 2 years (24 months)	90 days
Walk mowers - except as noted below + (over 30 inches of cutting width)	2 years (24 months) unlimited hours	90 days
+Coil over shocks and all suspension-related components	4 years (48 months) unlimited hours	90 days
+Hydro Drive Belt, Gearbox Drive Belt, Tires, Brake Pads, Hoses, Battery, Blades	90 days	90 days
+Mower Deck Drive Belt (Conventional Single Belt Deck Drive Systems)	1 year (12 months) or 100 hours, whichever occurs first	90 days
+Mower Deck Drive Belts (Two Belt Deck Drive Systems)	3 years (36 months) or 300 hours, whichever occurs first. (Parts and labor in year one; parts only in years two and three.)	90 days
+Attachments	1 year	90 days
+Engine*	See Engine Operator's Manual	See Engine Operator's Manual

\* Emissions-related components are covered by the Emissions Warranty Statement

\*\* In Australia - Our goods come with guarantees that cannot be excluded under the Australian Consumer Law. You are entitled to a replacement or refund for a major failure and for compensation for any other reasonably foreseeable loss or damage. You are also entitled to have the goods repaired or replaced if the goods fail to be of acceptable quality and the failure does not amount to a major failure. For warranty service, find the nearest Authorized Service Dealer in our dealer locator map at [ferrismowers.com](http://ferrismowers.com) (Select region: Australia), or by calling 1300 274 447, or by emailing or writing to [salesenquires@briggsandstratton.com.au](mailto:salesenquires@briggsandstratton.com.au), Briggs & Stratton Australia Pty Ltd, 1 Moorebank Avenue, NSW, Australia, 2170.

The warranty period begins on the date of purchase by the first retail or commercial customer.

To ensure prompt and complete warranty coverage, register your product at the website shown above or at [www.onlineproductregistration.com](http://www.onlineproductregistration.com), or mail the completed registration card (if provided), or call 1-800-743-4115 (in USA).

Save your proof of purchase receipt. If you do not provide proof of the initial purchase date at the time warranty service is requested, the manufacturing date of the product will be used to determine the warranty period. Product registration is not required to obtain warranty service on Briggs & Stratton products.

#### ABOUT YOUR WARRANTY

Warranty service is available only through *Ferris* Authorized Service Dealers. This warranty only covers defects in materials or workmanship. It does not cover damage caused by improper use or abuse, improper maintenance or repair, normal wear and tear, or stale or unapproved fuel.

**Improper Use and Abuse** - The proper, intended use of this product is described in the Operator's Manual. Using the product in a way not described in the Operator's Manual or using the product after it has been damaged will not be covered under this warranty. Warranty coverage will also not be provided if the serial number on the product has been removed or the product has been altered or modified in any way, or if the product has evidence of abuse such as impact damage, or water/chemical corrosion damage.

**Improper Maintenance or Repair** - This product must be maintained according to the procedures and schedules provided in the Operator's Manual, and serviced or repaired using genuine Briggs & Stratton parts or equivalent. Damage caused by lack of maintenance or use of non-original or non-equivalent parts is not covered by warranty.

**Normal Wear and Tear** - Like all mechanical devices, the unit is subject to wear even when properly maintained. This warranty does not cover replacement or repairs when normal use has exhausted the life of a part or the equipment. Except as noted in the warranty period, maintenance and wear items such as filters, belts, cutting blades, and brake pads (except engine brake pads) are not covered by warranty due to wear characteristics alone, unless the cause is due to defects in material or workmanship.

**Stale or Unapproved Fuel** - In order to function correctly, this product requires fresh fuel that conforms to the criteria specified in the Operator's Manual. Engine or equipment damage caused by stale fuel or the use of unapproved fuels (such as E15 or E85 ethanol blends) is not covered by warranty.

**Other Exclusions** - This warranty excludes damage due to accident, abuse, modifications, alterations, improper servicing, freezing or chemical deterioration. Attachments or accessories that were not originally packaged with the product are also excluded. This warranty does not include used, reconditioned, second-hand, or demonstration equipment or engines. This warranty also excludes failures due to acts of God and other force majeure events beyond the manufacturer's control.



