

## STANDARD EQUIPMENT

### ISO Standard cabin

All-weather steel cab with 360° visibility  
Safety glass windows  
Rise-up type windshield wiper  
Sliding fold-in front window  
Sliding side window(LH)  
Lockable door  
Hot & cool box  
Storage compartment & Ashtray  
Transparent cabin roof-cover  
CD/MP3 Player  
Handsfree mobile phone system with USB  
Sun visor

### Computer aided power optimization (New CAPO) system

3-power mode, 2-work mode, User mode  
Auto deceleration & one-touch deceleration system  
Auto warm-up system  
Auto overheat prevention system

### Automatic climate control

Full automatic temperature controller  
Defroster

### Self-diagnostics system

### Starting Aid (air grid heater) for cold weather

### Centralized monitoring

LCD display  
Engine speed or Trip meter/Accel.  
Clock  
Gauges  
Fuel level gauge  
Engine coolant temperature gauge  
Hyd. oil temperature gauge  
Warnings  
Check engine  
Overload  
Communication error  
Low battery  
Air cleaner clogging  
Indicators  
Max power  
Low speed/High speed  
Fuel warmer  
Auto idle

### Three outside rearview mirrors

### Fully adjustable suspension seat with seat belt

### Pilot-operated slidable joystick

### Console box height adjust system

### Four front working lights, one rear light

### Electric horn

### Batteries (2 x 12V x 200 AH)

### Battery master switch

### Removable clean-out dust net for cooler

### Automatic swing brake

### Automatic fuel line deaeration

### Fuel pre-filter with fuel warmer

### Boom holding system

### Arm holding system

### Counterweight (9,200kg, 20,280lb)

### Track shoes (600mm, 24")

### Track rail guard

### Accumulator for lowering work equipment

### Electric transducer

### Lower frame under cover (Normal)

### Viscous fan clutch

### Travel alarm

## OPTIONAL EQUIPMENT

### Fuel filler pump (50 L/min)

### Beacon lamp

### Safety lock valve for boom cylinder with overload warning device

### Safety lock valve for arm cylinder

### Single-acting piping kit (breaker, etc.)

### Double-acting piping kit (clamshell, etc.)

### Quick coupler

### 12 volt power outlet (24V DC to 12V DC converter)

### Booms

Heavy duty boom (7.06m,23'2")

Short boom (6.55m,21'6")

Long boom (9.0m,29'6")

### Arms

Heavy duty arm (3.38m,11'1")

Super short arm (2.4m,7'10")

Short arm (2.9m,9'6")

Long arm (5.85m,19'2")

### Climate control

Air conditioner only

Heater only

Air conditioner & heater manually

### Cabin FOPS/FOG (ISO/DIS 10262)

FOPS (Falling Object Protective Structure)

FOG (Falling Object Guard)

### Cabin roof-steel cover

### Cabin lights

### Cabin front window rain guard

### Track shoes

Triple grousers shoe (700mm, 28")

Triple grousers shoe (750mm, 30")

Triple grousers shoe (800mm, 32")

Triple grousers shoe (900mm, 36")

Double grousers shoe (600mm, 24")

Double grousers shoe (700mm, 28")

Full track rail guard

### Lower frame under cover (Additional)

### Pre-heating system, coolant

### Tool kit

### Operator suit

### Rearview camera

### Seat

Mechanical suspension seat

Air-suspension seat with heater

Air-suspension seat

### Pattern change valve (2 patterns)

### Oil washed air cleaner

### Hi-mate (Remote Management System)

\* Standard and optional equipment may vary. Contact your Hyundai dealer for more information. The machine may vary according to International standards.

\* The photos may include attachments and optional equipment that are not available in your area.

\* Materials and specifications are subject to change without advance notice.

\* All imperial measurements rounded off to the nearest pound or inch.

PLEASE CONTACT

## **HYUNDAI** HEAVY INDUSTRIES CO.,LTD. **CONSTRUCTION EQUIPMENT**

Head Office (Sales Office)  
1 JEONHA-DONG, DONG-GU, ULSAN, KOREA TEL: (82) 52-202-7970, 7729, 0971 FAX: (82) 52-202-7979, 7720

U.S. Operation: Hyundai Construction Equipment Americas, Inc.  
955 ESTES AVENUE, ELK GROVE VILLAGE, IL. 60007, U.S.A. TEL: (1) 847-437-3333 FAX: (1) 847-437-3574

European Operation: Hyundai Heavy Industries Europe N.V.  
VOSSENDAAL 11, 2440 GEEL, BELGIUM TEL: (32) 14-56-2200 FAX: (32) 14-59-3405

India Operation: Hyundai Construction Equipment India Pvt., Ltd.  
PLOT NO.A-2, CHAKAN INDUSTRIAL AREA, VILL- KHALUMBRE. TALUK.- KHED., DIST- PUNE 410 501, INDIA  
TEL: (91) 21-3530-1700 FAX: (91) 21-3530-1712

We build a better future

**Robex**

# 480LC-9

With Tier 3 Engine installed



Photo may include optional equipment.

# Pride at Work

Hyundai Heavy Industries strives to build state-of-the-art earthmoving equipment to give every operator maximum performance, more precision, versatile machine preferences, and proven quality. Take pride in your work with Hyundai!

## Robex 480LC-9

### Machine Walk-Around

#### Undercarriage

Sealed track chain (urethane seals) / Standard track rail guard / Comfortable bolt-on steps  
Large upper roller cut-outs for debris clean-out / Tapered side frames for debris clean-out / Grease-type track tensioner

#### Engine Technology

Proven / reliable, fuel efficient Cummins Tier III QSM11 engine  
Electronically controlled for optimum fuel to air ratio and clean, efficient combustion  
Low noise / Auto engine overheat feature / Anti-restart feature

#### Hydraulic System Improvements

New patented hydraulic control for improved controllability / Improved control valve design for added efficiency and smoother operation / New auto boom and swing priority system for optimum speed / New auto power boost feature for additional power when needed / Improved arm-in and boom-down flow regeneration system for added speed and efficiency

#### Pump Compartment

Industry-leading, powerful, reliable Kawasaki designed, variable volume in-line axial piston pumps  
New compact solenoid block equipped with 4 solenoid valves, 1 EPPR valves, 1 check valve accumulator and pilot filter - controls 2 speed travel, power boost, boom priority, safety lock

#### Enhanced Operator Cab

##### Improved Visibility

Enlarged cab with improved visibility / See-through upper skylight for visibility and ventilation  
Larger right-side glass, now one piece, for better right visibility  
Safety glass windows on all sides - less expensive than (polycarbonate) and won't scratch or fade  
Closeable sunshade for operator convenience / Reduced front window seam for improved operator view

##### Improved Cab Construction

New steel tube construction for added operator safety, protection and durability  
New window open/close mechanism designed with cable and spring lift assist and single latch release

##### Improved Suspension Seat / Console Assembly

Ergonomic joysticks with auxiliary control buttons for attachment use. Now with new sleek styling  
Heated suspension (standard) or optional air ride suspension with heat  
New joystick consoles - now adjustable in height by way of dial at bottom  
Adjustable arm rests - turn dial to raise or lower for optimum comfort

##### Advanced 7" Color Cluster

New Color LCD Display with easy to read digital gauges for hydraulic oil temperature, water temperature, and fuel. Simplified design makes adjustment and diagnostics easier. Also, new enhanced features such as rear-view camera are integrated into monitor.  
3 power modes : (P) Power, (S) Standard, (E) Economy, 2 work modes : Dig & Attachment, (U) User mode for operator preference  
Enhanced self-diagnostic features with GPS download capability  
One pump flow or two pump flow for optional attachment now selectable through the cluster / New anti-theft system with password capability  
Boom speed and arm regeneration are selectable through the monitor.  
Auto power boost is now available - selectable (on/off) through the monitor.  
Powerful air conditioning and heat with auto climate control, 20% more heat and air output than 7A series!  
RMS (Remote Management System) works through GPS/satellite technology to ultimately provide better customer service and support.

# Preference

Operating a 9 series is unique to every operator. Operators can fully customize their work environment and operating preferences to fit their individual needs.



\*Photo may include optional equipment.

## Operator Comfort

In 9 series cabin you can easily adjust the seat, console and armrest settings to best suit your preferred comfort level. Seat and console position and height can be set together and independent from each other. Other preference settings that add to overall operator comfort include the full automatic high capacity airconditioning system and the CD/MP3 radio.



## Reduced Stress

Work is stressful enough. Your work environment should be stress free. Hyundai's 9 series provides improved cab amenities, additional space and a comfortable seat to minimize stress to the operator. A powerful climate control system provides the operator with optimum air temperature. An advanced audio system with CD player, AM/FM stereo and MP3 capabilities, plus remotely located controls is perfect for listening to music favorites. Operators can even talk on the phone with the hands-free cell phone feature.



## Operator - Friendly Cluster

The advanced new cluster with 7 inch wide color LCD screen and toggle switch allows the operator to select his personal machine preferences. Power and work mode selection, self diagnostics, optional rear-view camera, maintenance check lists, start-up machine security, and video functions were integrated into the cluster to make the machine more versatile and the operator more productive.



## Wide Cabin with Excellent Visibility

The newly designed cabin was conceived for more space, a wider field of view and operator comfort. Special attention was given to a clear, open and convenient interior with plenty of visibility on the machine surroundings and the job at hand. This well balanced combination of precision aspects put the operator in the perfect position to work safely and securely.

# Precision

Innovative hydraulic system technologies make the 9 series excavator fast, smooth and easy to control.



## Computer Aided Power

The engine horsepower and hydraulic horsepower together in unison through the advanced CAPO(Computer Aided Power Optimization) system, flow for the job at hand. Operator can set their own preferences for boom or swing priority, power mode selection and optional work tools at the touch of a button.

The CAPO system also provides complete self diagnostic features and digital gauges for important information like hydraulic oil temperature, water temperatures and fuel level. This system interfaces with multiple sensors placed throughout the hydraulic system as well as the electronically controlled engine to provide the optimum level of engine power and hydraulic flow.

### Power Mode

P (Power Max) mode maximizes machine speed and power for mass production. S (Standard) mode provides a reduced, fixed rpm for optimum performance and improved fuel economy. For maximum fuel savings and improved control, E (Economy) mode provides precise flow and engine power based on load demand. Three unique power modes provide the operator with custom power, speed and fuel economy.

### Work Mode

The work mode allows the operator to select single flow attachments like a hydraulic breaker or bi-directional flow attachments like a crusher. Flow settings unique to each attachment can be programmed from within the cluster.

### User Mode

Some jobs require more precise machine settings. Using the versatile U (User) mode, the operator can customize engine speed, pump output, idle speed and other machine settings for the job at hand.

## Improved Hydraulic System



To achieve optimum precision, Hyundai redesigned the hydraulic system to provide the operator with super fine touch and improved controllability. Improved pump flow control reduces flow when controls are not being used to minimize fuel consumption.

Improved spool valves in the control valve are engineered to provide more precise flow to each function with less effort.

Improved hydraulic valves, precision-designed variable volume piston pumps, fine-touch pilot controls, and enhanced travel functions make any operator running a 9

series look like a smooth operator. Newly improved features include arm-in and boom-down flow regeneration, improved control valve technology and innovative auto boom and swing priority for optimal performance in any application.



## Auto Boom-swing Priority

This smart function automatically and continuously looks the ideal hydraulic flow balance for the boom and swing motions of the machine. The advanced CAPO system monitors the hydraulic system and adjusts its settings to maximize performance and productivity.

# Performance

9 series is designed for maximum performance to keep the operator working productively.



\*Photo may include optional equipment.

## Track Rail Guard & Adjusters

standard grease cylinder track adjusters and shock absorbing springs.



Durable track rail guards keep track links in place. Track adjustment is made easy with

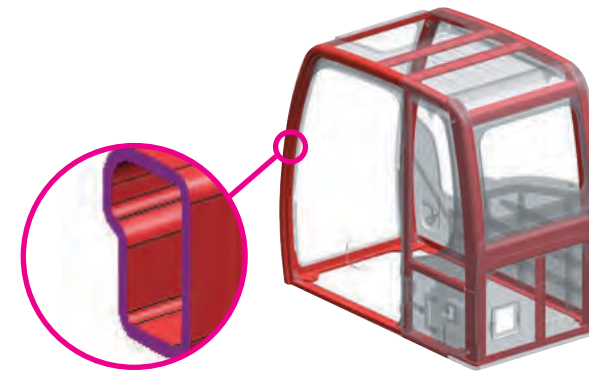

## Structure Strength

The 9 series cabin structure has been fitted with stronger but slimmer tubing for more safety and improved visibility. Low-stress, high strength steel is integrally welded to form a stronger, more durable upper and lower frame. Structural integrity was tested by way of FEM (Finite Elements Method) analysis and long-term durability tests.

## CUMMINS QSM11 Engine

The Tier III compliant, six cylinder, turbo-charged, 4 cycle, water cooled, Cummins QSM11 diesel engine is built for power, reliability, efficiency and reduced emissions.

## Heavy-duty strength

The QSM11 from Cummins. With advanced electronics. Higher torque. Better throttle response. Shorter service times. Longer maintenance intervals. Increased fuel economy. Decreased noise. Diagnostics. Prognostics. Engine protection, and more. All wrapped up in something we call the Quantum system.

The QSM11 is built to withstand the toughest work environment. Bearings have more surface area to handle higher loads with greater durability. The exhaust manifold allows for heat expansion and contraction, eliminating metal stress fractures. Reduced friction in the power cylinder means longer life and increased power output. From the structurally reinforced block to the stiffened gear housing, the QSM11 is built stronger to last longer.

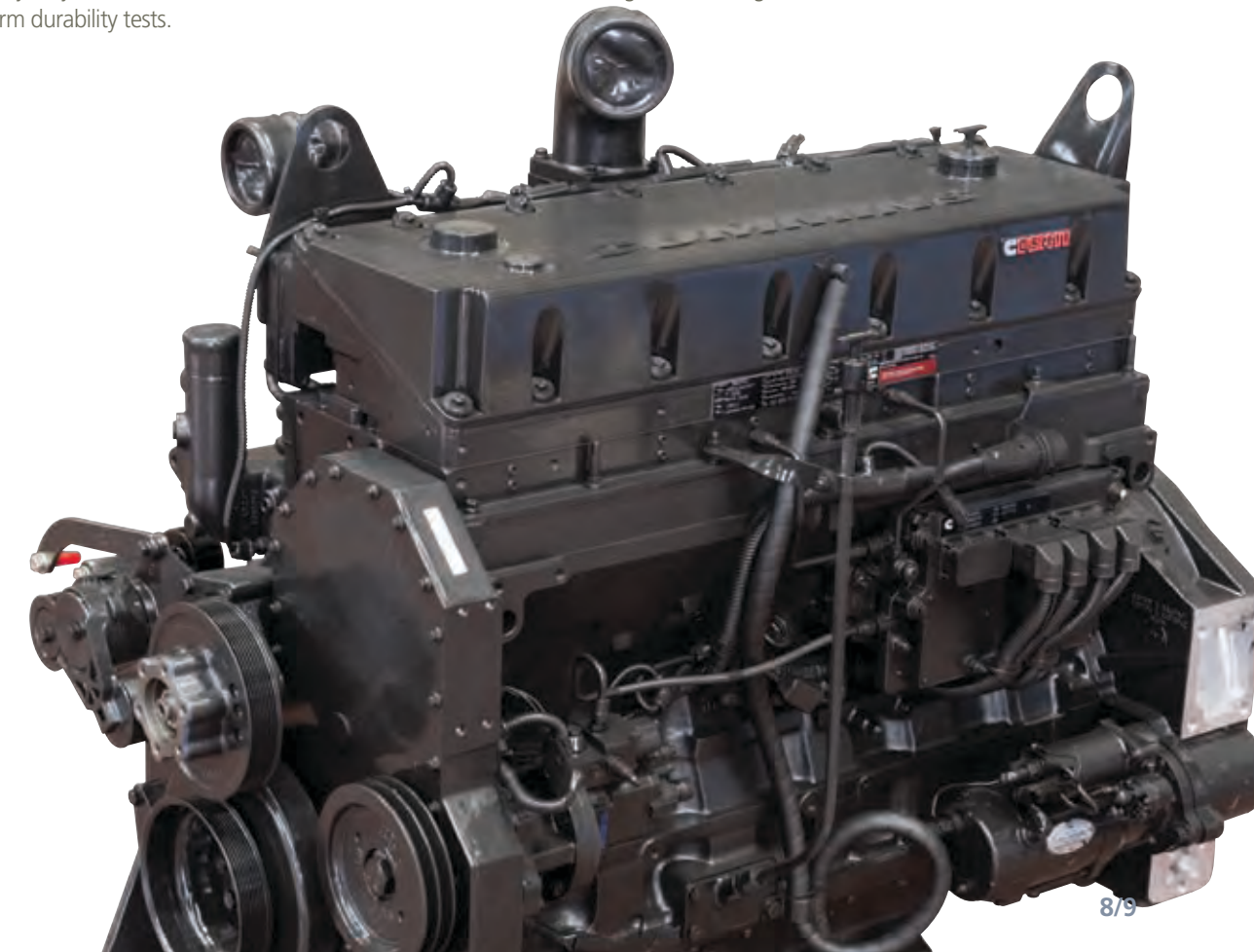

# Profitable

9 series is designed to maximize profitability through improved efficiencies, enhanced service features and longer life components.



## Hi-mate (Remote Management System)

Hi-mate, Hyundai's proprietary remote management system, provides operators and dealer service personnel access to vital service and diagnostic information on the machine from any computer with internet access. Users can pinpoint machine location using digital mapping and set machine work boundaries, reducing the need for multiple service calls. Hi-mate saves time and money for the owner and dealer by promoting preventative maintenance and reducing machine downtime.



## Fuel Efficient

9 series excavators are engineered to be extremely fuel efficient. New innovations like fan clutch, the variable speed remote fan, three-stage auto decel system and the new economy mode help to conserve fuel and reduce the impact on the environment.



## Easy Access

Ground-line access to filters, lube fittings, fuses, machine computer components and wide open compartments makes service more convenient on the 9 series.

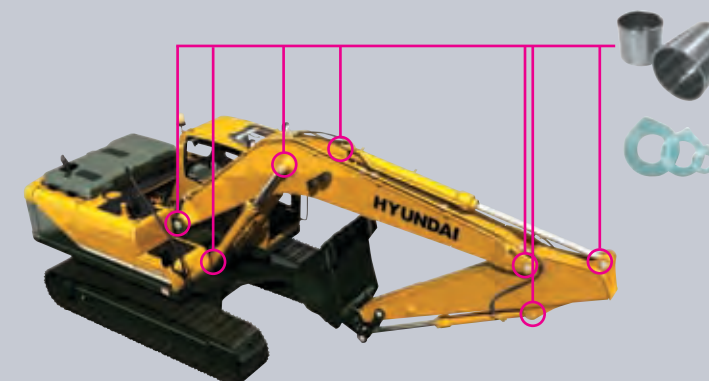

## Extended Life Components

9 series excavators were designed with extended lubricant bush life & ultra high molecular weight polymer shim (wear resistant, noise reducing), extended-life hydraulic filters (1,000hr), long-life hydraulic oil (5,000hr), more efficient cooling systems and integrated preheating systems to long extend service intervals, minimize operating costs and reduce machine down time.

\*Photo may include optional equipment.

# Specifications

## ENGINE

MODEL	CUMMINS QSM11		
Type	Water-cooled, 4-cycle Diesel, 6-Cylinder in-line, Direct injection, Turbocharged, Charge air cooled, Low emission		
Rated flywheel horsepower	SAE	J1995 (gross)	357HP (266kW)/ 1,900rpm
		J1349 (net)	342HP (255kW)/ 1,900rpm
DIN		6271/1 (gross)	362HP (266kW)/ 1,900rpm
		6271/1 (net)	347HP (255kW)/ 1,900rpm
Max. torque	170.8kgf-m (1,235lb-ft)/1,400rpm		
Bore X stroke	125mm X 147mm (4.92" X 5.79")		
Piston displacement	10,800cc (659 in <sup>3</sup> )		
Batteries	2 X 12V X 200AH		
Starting motor	24V, 7.2kW		
Alternator	24V, 70Amp		

## HYDRAULIC SYSTEM

MAIN PUMP	
Type	Variable displacement tandem-axis piston pumps
Max. flow	2 X 360 L/min (95.1 US gpm/79.2 UK gpm)
Sub-pump for pilot circuit	Gear pump

Cross-sensing and fuel saving pump system

HYDRAULIC MOTORS	
Travel	Two-speed axial pistons motor with brake valve and parking brake
Swing	Axial piston motor with automatic brake

RELIEF VALVE SETTING	
Implement circuits	330 kgf/cm <sup>2</sup> (4,690 psi)
Travel	345 kgf/cm <sup>2</sup> (4,910 psi)
Power boost (boom, arm, bucket)	360 kgf/cm <sup>2</sup> (5,120 psi)
Swing circuit	285 kgf/cm <sup>2</sup> (4,050 psi)
Pilot circuit	40 kgf/cm <sup>2</sup> (570 psi)
Service valve	Installed

HYDRAULIC CYLINDERS	
No. of cylinder bore X stroke	Boom: 2-170 X 1,570 mm (6.7" X 61.8")
	Arm: 1-190 X 1,820 mm (7.5" X 71.7")
	Bucket: 1-160 X 1,370 mm (6.3" X 53.9")

## DRIVES & BRAKES

Drive method	Fully hydrostatic type
Drive motor	Axial piston motor, in-shoe design
Reduction system	Planetary reduction gear
Max. drawbar pull	38,500 kgf (84,800 lbf)
Max. travel speed (high / low)	5.0 km/hr (3.1 mph) / 3.2 km/hr (2.0 mph)
Gradeability	35° (70 %)
Parking brake	Multi wet disc

## CONTROL

Pilot pressure operated joysticks and pedals with detachable lever provide almost effortless and fatigueless operation.

Pilot control	Two joysticks with one safety lever (LH): Swing and arm, (RH): Boom and bucket (ISO)
Traveling and steering	Two levers with pedals
Engine throttle	Electric, Dial type
Lights	Four lights mounted on the boom, one light mounted under the battery box one light mounted under the cabin one light mounted on the countweight

## SWING SYSTEM

Swing motor	Axial pistons motor
Swing reduction	Planetary gear reduction
Swing bearing lubrication	Grease-bathed
Swing brake	Multi wet disc
Swing speed	9.0 rpm

## COOLANT & LUBRICANT CAPACITY

Re-filling	liter	US gal	UK gal
Fuel tank	621	164	136.6
Engine coolant	50.0	13.2	11.0
Engine oil	37.9	10.0	8.3
Swing device - gear oil	5.0	1.3	1.1
Final drive (each) - gear oil	5.0	1.3	1.1
Hydraulic system (including tank)	380	100.4	83.6
Hydraulic tank	262	69.2	57.6

## UNDERCARRIAGE

The X-leg type center frame is integrally welded with reinforced box-section track frames. The undercarriage includes lubricated rollers, idlers, track adjusters with shock absorbing springs and sprockets, and a track chain with double or triple grouser shoes.

Center frame	X-leg type
Track frame	Pentagonal box type
No. of shoes on each side	53
No. of carrier rollers on each side	2
No. of track rollers on each side	9
No. of rail guards on each side	2

## OPERATING WEIGHT (APPROXIMATE)

Operating weight, including 7,060mm (23' 2") boom, 3,380mm (11' 1") arm, SAE heaped 2.15m<sup>3</sup> (2.81 yd<sup>3</sup>) bucket, lubricant, coolant, full fuel tank, full hydraulic tank, and all standard equipments.

MAJOR COMPONENT WEIGHT	
Upperstructure	10,940kg (24,120lb)
Counterweight	9,200kg (20,280lb)
Boom (with arm cylinder)	4,110kg (9,060lb)

## OPERATING WEIGHT

Shoes		Operating weight	Ground pressure
Type	Width mm (in)	kg (lb)	kgf/cm <sup>2</sup> (psi)
Triple grouser	600 mm (24")	48,100 (106,040)	0.83 (11.80)
	700 mm (28")	48,640 (107,230)	0.72 (10.24)
	750 mm (30")	48,910 (107,830)	0.68 (9.67)
	800 mm (32")	49,180 (108,420)	0.64 (9.10)
Double grouser	900 mm (36")	49,720 (109,610)	0.57 (8.11)
	600 mm (24")	48,100 (106,040)	0.83 (11.80)
	700 mm (28")	48,640 (107,230)	0.72 (10.24)

## BUCKETS

All buckets are welded with high-strength steel.

SAE heaped m <sup>3</sup> (yd <sup>3</sup> )		1.00 (1.31)		1.84 (2.41)		2.79 (3.65)		2.20 (2.88)		2.43 (3.18)
		1.38 (1.80)		2.15 (2.81)		3.03 (3.96)				
Capacity m <sup>3</sup> (yd <sup>3</sup> )		Width mm (in)		Weight kg (lb)	Recommendation mm (ft-in)					
SAE heaped	CECE heaped	Without sidecutters	With sidecutters		7,060(23' 2") Boom				6,550(21' 6") Boom	9,000(29' 6") Boom
				2,400 (7' 10") Arm	2,900 (9' 6") Arm	3,380(11' 1") Arm	4,000(13' 1") Arm	2,400 (7' 10") Arm	5,850(19' 2") Arm	
1.00 (1.31)	0.9 (1.17)	915 (36.0)	1,065 (41.9)	1,220 (2,690)	●	●	●	●	●	●
1.38 (1.80)	1.25 (1.63)	1,100 (43.3)	1,250 (49.2)	1,420 (3,130)	●	●	●	●	●	■
1.84 (2.41)	1.65 (2.16)	1,140 (44.9)	1,290 (50.8)	1,520 (3,350)	●	●	●	■	●	-
2.15 (2.81)	1.92 (2.51)	1,415 (55.7)	1,565 (61.6)	1,740 (3,840)	●	●	■	▲	●	-
2.79 (3.65)	2.47 (3.23)	1,760 (69.3)	1,910 (75.2)	1,960 (4,320)	■	■	▲	-	●	-
3.03 (3.96)	2.67 (3.49)	1,890 (74.4)	2,040 (80.3)	2,090 (4,610)	▲	▲	-	-	■	-
● 2.20 (2.88)	1.80 (2.35)	1,840 (72.4)	-	2,295 (5,060)	●	●	■	-	●	-
● 2.43 (3.18)	2.10 (2.75)	1,885 (74.2)	-	2,335 (5,150)	▲	-	-	-	■	-

● Rock-Heavy duty bucket

●: Applicable for materials with density of 2,000 kg /m<sup>3</sup> (3,370 lb/ yd<sup>3</sup>) or less  
 ■: Applicable for materials with density of 1,600 kg /m<sup>3</sup> (2,700 lb/ yd<sup>3</sup>) or less  
 ▲: Applicable for materials with density of 1,100 kg /m<sup>3</sup> (1,850 lb/ yd<sup>3</sup>) or less

## ATTACHMENT

Booms and arms are welded with a low-stress, full-box section design. 6,550mm(21' 6"), 7,060mm(23' 2"), 9,000mm(29' 6")boom and 2,400mm(7' 10"), 2,900mm(9' 6"), 3,380mm(11' 1"), 4,000mm(13' 1"), 5,850mm(19' 2")arms are available.

## DIGGING FORCE

Boom	Length	mm (ft-in)	7,060(23' 2")				Remarks
	Weight	kg (lb)	3,260 (7,180)				
Arm	Length	mm (ft-in)	2,400 (7' 10")	2,900 (9' 6")	3,380 (11' 1")	4,000 (13' 1")	[ ]: Power Boost
	Weight	kg (lb)	2,070 (4,560)	2,230 (4,920)	2,100 (4,630)	2,370 (5,220)	
Bucket digging force	SAE	kN	216.7 [236.4]	219.7 [239.6]	220.7 [240.7]	222.6 [242.9]	
		kgf	22,100 [24,110]	22,400 [24,440]	22,500 [24,550]	22,700 [24,760]	
		lbf	48,720 [53,150]	49,380 [53,870]	49,600 [54,110]	50,040 [54,590]	
	ISO	kN	251.1 [273.9]	254.0 [277.1]	255.0 [278.2]	256.9 [280.3]	
		kgf	25,600 [27,930]	25,900 [28,250]	26,000 [28,360]	26,200 [28,580]	
		lbf	56,440 [61,570]	57,100 [62,290]	57,320 [62,530]	57,760 [63,010]	
Arm crowd force	SAE	kN	276.6 [301.7]	224.6 [245.0]	191.2 [208.6]	170.6 [186.2]	
		kgf	28,200 [30,760]	22,900 [24,980]	19,500 [21,270]	17,400 [18,980]	
		lbf	62,170 [67,820]	50,490 [55,080]	42,990 [46,900]	38,360 [41,850]	
	ISO	kN	290.3 [316.7]	234.4 [255.7]	199.1 [217.2]	176.5 [192.6]	
		kgf	29,600 [32,290]	23,900 [26,070]	20,300 [22,150]	18,000 [19,640]	
		lbf	65,260 [71,190]	52,690 [57,480]	44,750 [48,820]	39,680 [43,290]	

Note: Boom weight includes arm cylinder, piping, and pin  
 Arm weight includes bucket cylinder, linkage, and pin

# Dimensions & Working Range

## R480LC-9 DIMENSIONS

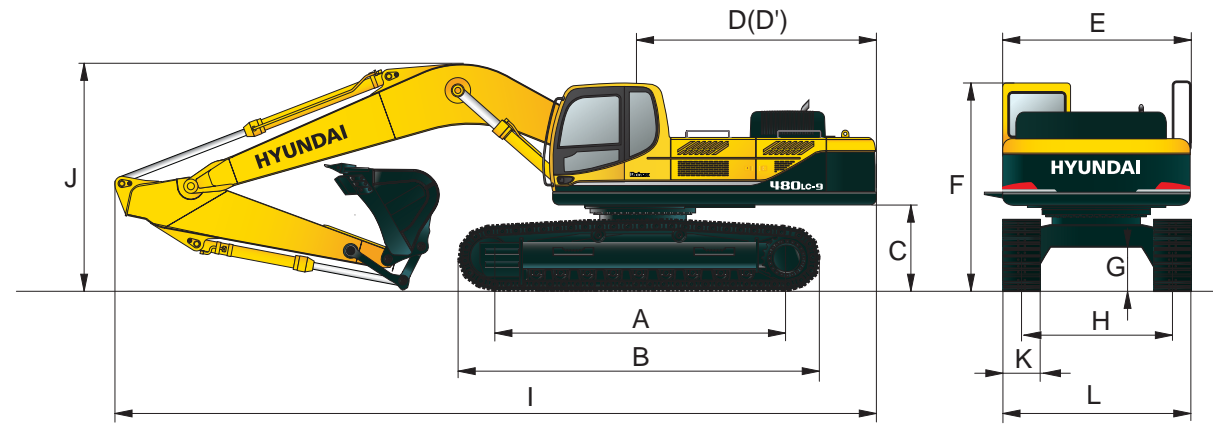

mm (ft-in)		mm (ft-in)							
A Tumbler distance	4,470 (14' 8")	Boom length		7,060 (23' 2")		6,550 (21' 6")		9,000 (29' 6")	
B Overall length of crawler	5,462 (17' 11")	Arm length		2,400 (7' 10")	2,900 (9' 6")	3,380 (11' 1")	4,000 (13' 1")	2,400 (7' 10")	5,850 (19' 2")
C Ground clearance of counterweight	1,295 (4' 3")	I Overall length		12,270 (40' 3")	12,200 (40' 0")	12,060 (39' 7")	12,040 (39' 6")	11,770 (38' 5")	13,660 (44' 10")
D Tail swing radius	3,750 (12' 4")	J Overall height of boom		3,840 (12' 7")	3,770 (12' 4")	3,730 (12' 3")	4,040 (13' 3")	4,030 (13' 3")	5,200 (17' 1")
D' Rear-end length	3,695 (12' 1")	K Track shoe width		600 (24")	700 (28")	750 (30")	800 (32")	900 (36")	
E Overall width of upperstructure	2,980 (9' 9")	L Overall width		3,340 (10' 11")	3,440 (11' 3")	3,490 (11' 5")	3,540 (11' 7")	3,640 (11' 11")	
F Overall height of cab	3,190 (10' 6")								
G Min. ground clearance	555 (1' 10")								
H Track gauge	2,740 (9' 0")								

## R480LC-9 WORKING RANGE

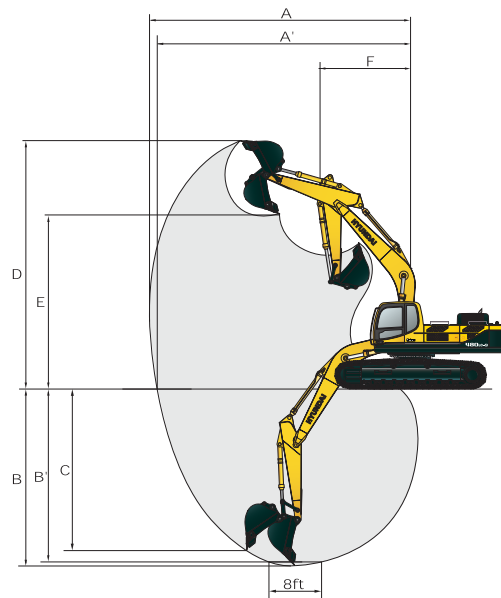

		mm (ft-in)					
Boom length		7,060 (23' 2")		6,550 (21' 6")		9,000 (29' 6")	
Arm length		2,400 (7' 10")	2,900 (9' 6")	3,380 (11' 1")	4,000 (13' 1")	2,400 (7' 10")	5,850 (19' 2")
A	Max. digging reach	11,160 (36' 7")	11,550 (37' 11")	12,100 (39' 8")	12,660 (41' 6")	10,610 (34' 10")	16,350 (53' 8")
A'	Max. digging reach on ground	10,940 (35' 11")	11,340 (37' 2")	11,900 (39' 1")	12,470 (40' 11")	10,370 (34' 0")	16,200 (53' 2")
B	Max. digging depth	6,850 (22' 6")	7,350 (24' 1")	7,810 (25' 7")	8,450 (27' 9")	6,370 (20' 11")	11,560 (37' 11")
B'	Max. digging depth (8' level)	6,670 (21' 11")	7,190 (23' 7")	7,670 (25' 2")	8,320 (27' 4")	6,190 (20' 4")	11,460 (37' 7")
C	Max. vertical wall digging depth	5,960 (19' 7")	5,930 (19' 5")	6,590 (21' 7")	7,170 (23' 6")	5,400 (17' 9")	10,320 (33' 10")
D	Max. digging height	10,560 (34' 8")	10,530 (34' 7")	10,980 (36' 0")	11,210 (36' 9")	10,170 (33' 4")	13,840 (45' 5")
E	Max. dumping height	7,120 (23' 4")	7,180 (23' 7")	7,620 (25' 0")	7,820 (25' 8")	6,750 (22' 2")	10,440 (34' 3")
F	Min. swing radius	5,090 (16' 8")	4,910 (16' 1")	4,780 (15' 8")	4,910 (16' 1")	4,620 (15' 2")	5,940 (19' 6")

# Lifting Capacity

## R480LC-9

Rating over-front Rating over-side or 360 degree

Boom : 6.55m (21' 6") / Arm : 2.40 m (7' 10") / Bucket : 2.15 m<sup>3</sup> (2.81 yd<sup>3</sup>) SAE heaped / Shoe : 600mm (24") triple grouser with 9,200kg (20,280 lb) Counterweight

Load point height m (ft)		Load radius								At max. reach		
		3.0 m (10.0 ft)		4.5 m (15.0 ft)		6.0 m (20.0 ft)		7.5 m (25.0 ft)		Capacity	Reach	
6.0 m (25.0 ft)	kg					*12480	*12480	*11020	9310	*9470	6570	9.15
	lb					*27510	*27510	*24290	20530	*20880	14480	(30.0)
4.5 m (20.0 ft)	kg			*18440	*18440	*13960	13040	11650	9010	*9440	5790	9.65
	lb			*40650	*40650	*30780	28750	25680	19860	*20810	12760	(31.7)
3.0 m (15.0 ft)	kg					*15580	12220	12420	8610	*9470	5410	9.86
	lb					*34350	26940	27380	18980	*20880	11930	(32.3)
1.5 m (5.0 ft)	kg					*16700	11550	13000	8240	*9510	5340	9.80
	lb					*36820	25460	28660	18170	*20970	11770	(32.2)
Ground	kg			*22790	17330	*16900	11170	13090	8000	*9480	5590	9.47
Line	lb			*50240	38210	*37260	24630	28860	17640	*20900	12320	(31.1)
-1.5 m (-5.0 ft)	kg	*25320	*25320	*20990	17370	*16060	11060	12360	7920	*9240	6280	8.83
	lb	*55820	*55820	*46270	38290	*35410	24380	27250	17460	*20370	13850	(29.0)
-3.0 m (-10.0 ft)	kg	*21780	*21780	*17910	17670	*13920	11190			*8390	7800	7.79
	lb	*48020	*48020	*39480	38960	*30690	24670			*18500	17200	(25.6)
-4.5 m (-15.0 ft)	kg			*12770	*12770							
	lb			*28150	*28150							

Boom : 7.06m (23' 2") / Arm : 2.40 m (7' 10") / Bucket : 2.15 m<sup>3</sup> (2.81 yd<sup>3</sup>) SAE heaped / Shoe : 600mm (24") triple grouser with 9,200kg (20,280 lb) Counterweight

Load point height m (ft)		Load radius								At max. reach				
		3.0 m (10.0 ft)		4.5 m (15.0 ft)		6.0 m (20.0 ft)		7.5 m (25.0 ft)		9.0 m (30.0 ft)		Capacity	Reach	
6.0 m (20.0 ft)	kg					*12000	*12000	*10370	9210			*8610	5730	9.75
	lb					*26460	*26460	*22860	20300			*18980	12630	(32.0)
4.5 m (15.0 ft)	kg					*13640	12660	*11150	8820			*8600	5100	10.21
	lb					*30070	27910	*24580	19440			*18960	11240	(33.5)
3.0 m (10.0 ft)	kg					*15310	11770	*12010	8370	*10080	6180	8630	4780	10.41
	lb					*33750	25950	*26480	18450	*22220	13620	19030	10540	(34.2)
1.5 m (5.0 ft)	kg					*16370	11110	*12650	7990	*10340	5980	8590	4720	10.36
	lb					*36090	24490	*27890	17610	*22800	13180	18940	10410	(34.0)
Ground	kg					*16540	10780	*12830	7740	*10270	5850	*8720	4930	10.05
Line	lb					*36460	23770	*28290	17060	*22640	12900	*19220	10870	(33.0)
-1.5 m (-5.0 ft)	kg			*20270	16950	*15820	10710	*12360	7660			*8570	5470	9.46
	lb			*44690	37370	*34880	23610	*27250	16890			*18890	12060	(31.0)
-3.0 m (-10.0 ft)	kg	*20660	*20660	*17780	17250	*14130	10850	*10900	7770			*8040	6620	8.51
	lb	*45550	*45550	*39200	38030	*31150	23920	*24030	17130			*17730	14590	(27.9)
-4.5 m (-15.0 ft)	kg			*13800	*13800	*10900	*10900					*6360	*6360	7.04
	lb			*30420	*30420	*24030	*24030					*14020	*14020	(23.1)

- Lifting capacity is based on SAE J1097, ISO 10567.
- Lifting capacity of the Robex Series does not exceed 75% of the tipping load with the machine on firm, level ground or 87% of full hydraulic capacity.
- The load point is a hook located on the back of the bucket.
- (\*) indicates the load limited by hydraulic capacity.



