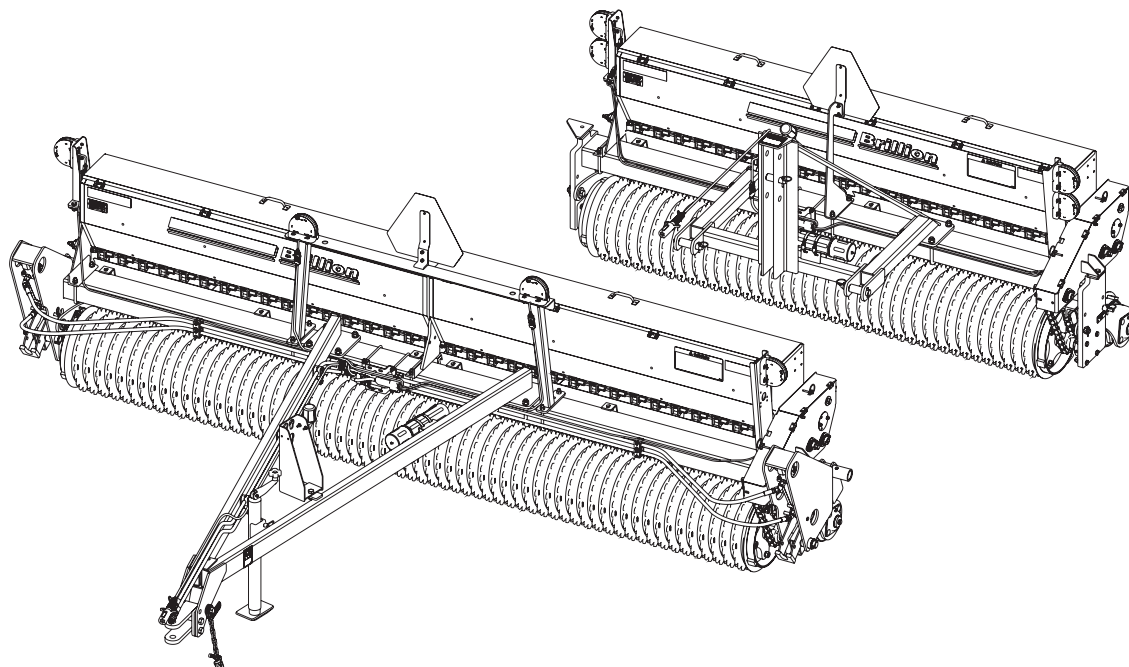




**Mid-Size  
Sure Stand Seeder  
Models SS108/SS110/SS112  
SSP108/SSP110/SSP112  
Operator's Manual**



**LANDOLL COMPANY, LLC**

1900 North Street

Marysville, Kansas 66508

(785) 562-5381

800-428-5655 ~ [WWW.LANDOLL.COM](http://WWW.LANDOLL.COM)

**Manuals for Mid-Size Sure Stand Seeder,  
Models SS108/SS110/SS112 and SSP108/SSP110/SSP112**

Manual Number	Manual Type
9K713	Operator's Manual
9K712	Parts Manual

# Table of Contents

---

## 1 Safety Information

Introduction . . . . .	1-1
Description of Unit . . . . .	1-1
Using this Manual . . . . .	1-1
Owner Assistance . . . . .	1-1
Warranty Registration . . . . .	1-1
Safety . . . . .	1-2
Understanding Safety Statements . . . . .	1-2
Transporting Safety . . . . .	1-2
Safety Instructions for Towing Vehicles . . . . .	1-3
Maintenance Safety . . . . .	1-3
Protective Equipment . . . . .	1-3
Tire Safety . . . . .	1-3
Chemical Safety . . . . .	1-3
Prepare for Emergencies . . . . .	1-3
Safety Chain . . . . .	1-4
Decals . . . . .	1-5

## 2 Assembly

3-PT Seeder Assembly . . . . .	2-2
Tire and Wheel Installation . . . . .	2-5
Hydraulic Installation . . . . .	2-6
Purge the Hydraulic Lift System . . . . .	2-9
Warning Lamp Installation, 8FT and 10FT . . . . .	2-10
Warning Lamp Installation, 12FT . . . . .	2-12
Electric Clutch Kit - Optional . . . . .	2-15
Seed Shaft Sensor Kit - Optional . . . . .	2-18
Seed Shaft Sensor Console and Harness Installation . . . . .	2-20
Scraper Kit - Optional . . . . .	2-22
S-Tine Tire Track Remover Kit - Optional . . . . .	2-24
Coil Tine Track Remover - Optional . . . . .	2-26

## 3 Operation

Tractor Preparation . . . . .	3-2
Tractor Preparation/Attaching of 3-PT Seeder . . . . .	3-2
Attaching/Detaching 3-PT Hitch Seeder . . . . .	3-4
Tractor Preparation/Attaching of Pull Type Seeder . . . . .	3-5
Attaching/Detaching Pull Type Seeder . . . . .	3-6
Hydraulic Lift System . . . . .	3-7
Transmission Electric Clutch - Optional . . . . .	3-7
Seed Box Seed Rate Adjustment . . . . .	3-8
Transmission Drive Bolt . . . . .	3-10
Calibration for Unlisted Seeds . . . . .	3-10
Speed-Up Kit - Optional . . . . .	3-12

Loup Acre Meter Kit - Optional (After 05/15/2012) . . . . .	3-13
Loup Acre Meter Kit - Optional (Before 05/15/2012) . . . . .	3-14
Seed Shaft Sensor Console with Clutch Control - Optional . . . . .	3-17
General Operation . . . . .	3-17
Transporting the Seeder . . . . .	3-17

## **4 Maintenance**

General Torque Specifications . . . . .	4-1
Hydraulic Fitting Torque Specifications . . . . .	4-2
Fasteners . . . . .	4-2
Tires . . . . .	4-3
Lubrication Maintenance . . . . .	4-3
Hydraulic Maintenance . . . . .	4-5
Front and Rear Rollers . . . . .	4-5
Roller Adjustment Procedure . . . . .	4-5
Chain Tension . . . . .	4-6
Seed Meter Adjustment . . . . .	4-7
LED Warning Lamps . . . . .	4-8
Electric Clutch - Optional . . . . .	4-9


## **5 Specifications**



# Safety Information

## Introduction

The implement described in this manual has been designed with care and built by skilled workers using quality materials and processes. Proper assembly, maintenance and safe operation will allow this machine to provide you with satisfactory use for seasons to come.


DANGER

**Read this entire manual before attempting to assemble, adjust or operate this machine. Failure to comply with this warning can result in personal injury or death, damage to the machine or its components and inferior operation.**

## Description of Unit

The Brillion Sure Stand Agriculture Seeder provides precision seed metering and accurate seed depth placement, offering optimum germination. The SS1 Series Seeder offers more capacity by utilizing a Mid-Size Seed Box with micro-meters, spaced 4-1/4" for an even better distribution of small seed varieties. Units are available in 3-PT Hitch and Drawbar.

## Using this Manual

This manual will familiarize you with safety, assembly, operation, adjustment, and maintenance. Read this manual and follow the recommendations to help ensure safe and efficient operation.

- The information in this manual is current at time of printing. Some parts may change to assure top performance.
- Location reference: Right and Left designations in this manual are determined by facing the direction the machine will travel during field operation, unless otherwise stated.

## Owner Assistance

If customer service or repairs are needed, contact your Brillion dealer. Your machine's parts should only be replaced with Brillion parts. Have the Serial Number and complete Model Number available when ordering parts from your Brillion dealer. If items covered in this manual are not understood, contact your local Brillion dealer.

## Warranty Registration

Brillion Farm Equipment, by Landoll, shall have no warranty obligation unless each product is registered, within 10 days of retail purchase, using the Landoll Company, LLC Ag Products on-line registration process. Please refer to the Ag Products Policy and Procedures Manual, accessible at [www.landoll.com](http://www.landoll.com) for step by step instructions regarding product registration.

Enter your product information below for quick reference.

Refer to the ID plate as shown in **Figure 1-1**. The ID plate is located on the right front of the machine.

MODEL NUMBER

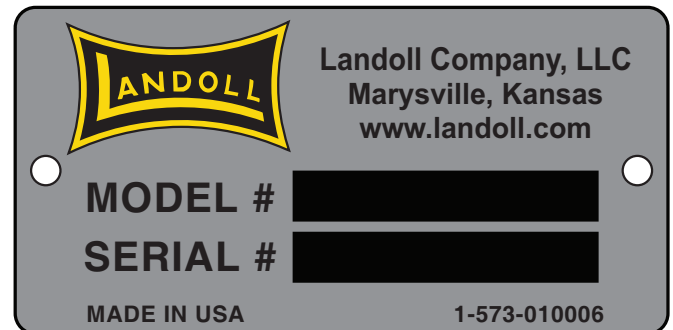
---

SERIAL NUMBER

---

DATE OF PURCHASE

---



**Figure 1-1: ID Plate**

**SAFETY INFORMATION**

# Safety

**NOTE**

*Investigation has shown that nearly 1/3 of all farm accidents are caused by careless use of machinery. Insist that all people working with you or for you abide by all safety instructions.*

## Understanding Safety Statements

You will find various types of safety information on the following pages and on the machine decals (signs) attached to the implement. This section explains their meaning.

<b>NOTICE</b>
Special notice - read and thoroughly understand.

<b>CAUTION</b>
Proceed with caution. Failure to heed caution <u>may</u> cause injury to person or damage product.

<b>WARNING</b>
Proceed with caution. Failure to heed warning <u>will</u> cause injury to person or damage product.

<b>DANGER</b>
Proceed with extreme caution. Failure to heed notice will cause injury or death to person and/or damage product.

**NOTE**

*You should read and understand the information contained in this manual and on the machine decals before you attempt to operate or maintain this equipment.*

- Examine safety decals and be sure you have the correct safety decals for the machine. **See Figure 1-3.**
- Order replacement decals through your Brillion dealer.
- Keep these signs clean so they can be observed readily. It is important to keep these decals cleaned more frequently than the machine. Wash with soap and water or a cleaning solution as required.
- Replace decals that become damaged or lost. Also, be sure that any new machine components installed during repair include decals which are assigned to them by the manufacturer.

- When applying decals to the machine, be sure to clean the surface to remove any dirt or residue. Where possible, sign placement should protect the sign from abrasion, damage, or obstruction from mud, dirt, oil etc.

<b>DANGER</b>
<ul style="list-style-type: none"> <li>• <b>Do not allow anyone to ride on tractor or machine. Riders could be struck by foreign objects or thrown from the machine.</b></li> <li>• <b>Never allow children to operate equipment.</b></li> <li>• <b>Keep bystanders away from machine during operation.</b></li> </ul>

## Transporting Safety

**IMPORTANT**

**It is the responsibility of the owner/operator to comply with all state and local laws.**

- When transporting the machine on a road or highway, use adequate warning symbols, reflectors, lights and slow moving vehicle sign as required. Slow moving tractors and towed implements can create a hazard when driven on public roads. They are difficult to see, especially at night.
- Do not tow an implement that, when fully loaded, weighs more than 1.5 times the weight of the towing vehicle.
- Carry reflectors or flags to mark tractor and implement in case of breakdown on the road.
- Do not transport at speeds over 20 MPH under good conditions. Never travel at a speed which does not allow adequate control of steering and stopping. Reduce speed if towed load is not equipped with brakes
- Avoid sudden stops or turns because the weight of the machine may cause the operator to lose control of the tractor. Use a tractor heavier than the machine.
- Use caution when towing behind articulated steering tractors; fast or sharp turns may cause the machine to shift sideways.
- Keep clear of overhead power lines and other obstructions when transporting. Know transport height and width of your machine. Refer to transport dimensions on **Page 5-1.**

## Safety Instructions for Towing Vehicles

The maximum travel speed is the lesser of

- The limit of the road conditions;
- The maximum specified ground speed;
  - for towing operations as indicated in this manual or SIS;
  - of the towed vehicle as indicated in its operator's manual, SIS, or information sign;
- The maximum ground speed of the towed equipment combination shall be limited to the lowest specified ground speed of any of the towed machines. This speed is the ground speed limitation.

**EXAMPLE:** If the tractor is capable of 25 mph, the first implement has a SIS for 19 mph, and the last implement's operator's manual states its specified ground speed is 15 mph, the towed equipment combination ground speed limitation is 15 mph.

## Attaching, Detaching and Storage

- Do not stand between the tractor and machine when attaching or detaching machine unless both are not moving.
- Before applying pressure to the hydraulic system, be sure all connections are tight and that hydraulic hoses are not damaged.
- Completely raise machine and install transport locks. If desired to store lowered and on unpaved surface, place hardwood blocks under roller to keep off ground.
- Block implement so it will not roll when unhitched from the tractor.
- Relieve pressure in hydraulic lines before uncoupling hydraulic hoses from tractor.
- Use a Safety Chain to help control drawn machinery should it separate from the tractor drawbar.

### NOTE

*To relieve hydraulic pressure: Depending on tractor hydraulic system, some can be relieved by actuating control lever after engine is stopped. If tractor has electric over hydraulic controls, it may be necessary to move the control lever to the float position. Refer to tractor's operator's manual.*

*Wear protective gloves and safety glasses and goggles when working with hydraulic systems.*

## Maintenance Safety

- Block the machine so it will not roll when working on or under it to prevent injury.
- Transport Locks installed.
- Do not make adjustments or lubricate machine while it is in motion.

- Make sure all moving parts have stopped and all system pressure is relieved.
- Understand the procedure before doing the work. Use proper tools and equipment.

## Protective Equipment

- Wear protective clothing and equipment appropriate for the job. Avoid loose fitting clothing.
- Because prolonged exposure to loud noise can cause hearing impairment or hearing loss, wear suitable hearing protection, such as earmuffs or earplugs.

## Tire Safety

Tire changing can be dangerous and should be performed by trained personnel using correct tools and equipment.

- When inflating tires, use a clip-on chuck and extension hose long enough to allow you to stand to one side, not in front of or over the tire assembly. Use a safety cage if available.
- When removing and installing wheels, use wheel-handling equipment adequate for weight involved.

## Chemical Safety

Agricultural chemicals can be dangerous. Improper use can seriously injure persons, animals, plants, soil & property.

- Read chemical manufacturer's instructions and store or dispose of unused chemicals as specified. Handle chemicals with care & avoid inhaling smoke from any type of chemical fire.
- Store or dispose of unused chemicals as specified by the chemical manufacturer.

## Prepare for Emergencies

- Keep a First Aid Kit and Fire Extinguisher handy
- Keep emergency numbers for doctor, ambulance, hospital and fire department near phone.

## High Pressure Fluid Safety

Escaping fluid under pressure can be nearly invisible and have enough force to penetrate the skin causing serious injury. Use a piece of cardboard, rather than hands, to search for suspected leaks.

- Any fluid injected into the skin must be surgically removed within a few hours or gangrene may result.
- Avoid the hazard by relieving pressure before disconnecting hydraulic lines.

### NOTE

*Relieve hydraulic pressure by shifting the control valve lever to float.*

*Wear protective gloves and safety glasses or goggles when working with hydraulic systems.*

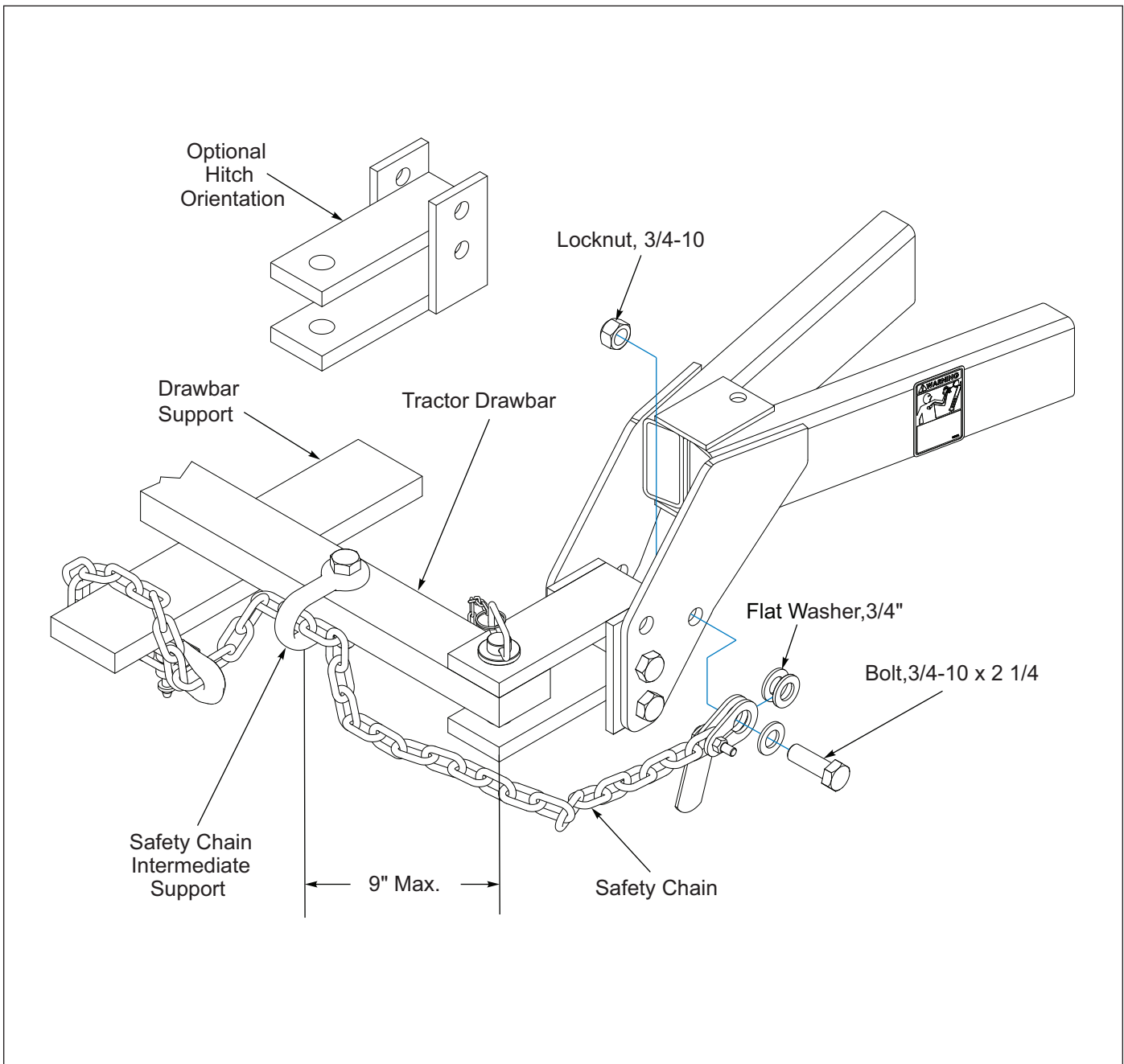
**SAFETY INFORMATION**

**Safety Chain**

1. Use a Safety Chain to help control drawn machinery should it separate from the Tractor Drawbar.
2. Use a chain with a strength rating equal to or greater than the gross weight of towed machinery, which is 10,100 pounds minimum in accordance with ASAE S338.2 specifications. If two or more machines are pulled in tandem, a larger chain may be required. Chain capacity must be greater than the TOTAL weight of all towed implements.

A second chain should be used between each implement.

3. Attach the chain to the Tractor Drawbar Support or specified anchor location. Never attach the chain to an intermediate support. Allow only enough slack in the chain to permit turning. The distance from Hitch Pin to attachment point or intermediate support point should not exceed 9 inches. If the distance from the Drawbar Pin to either the front or rear attachment point exceeds 9 inches, intermediate chain is required. **See Figure 1-2.**
4. Replace chain if any links or end fittings are broken, stretched or damaged.
5. Do not use a safety chain for towing.



**Figure 1-2: Safety Chain**

Decals

**ITEM 1**  
4K039

**ITEM 2**  
4K387

**ITEM 3**  
9K349

**ITEM 4**  
528933

**ITEM 5**  
528938

**ITEM 6**  
2K123

**ITEM 7**  
9K348

**ITEM 8**  
8J309

**ITEM 9**  
528934

**ITEM 10**  
1-573-010006

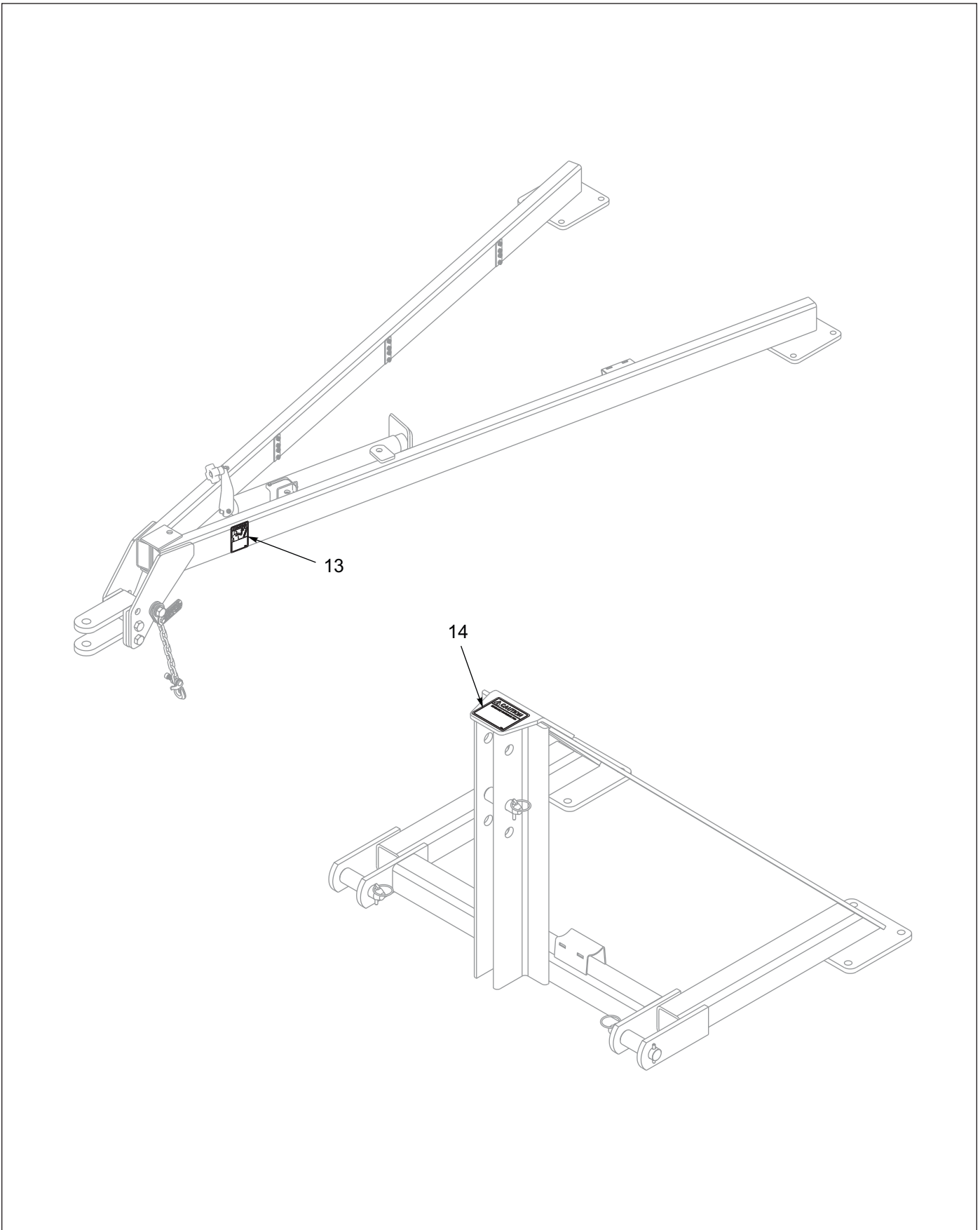
**ITEM 11**  
9J301

**ITEM 12**  
2P151

**ITEM 13**  
3K706

**ITEM 14**  
9J302

Figure 1-3: Decals



**Figure 1-4: Decal Placement - Hitch Decals**

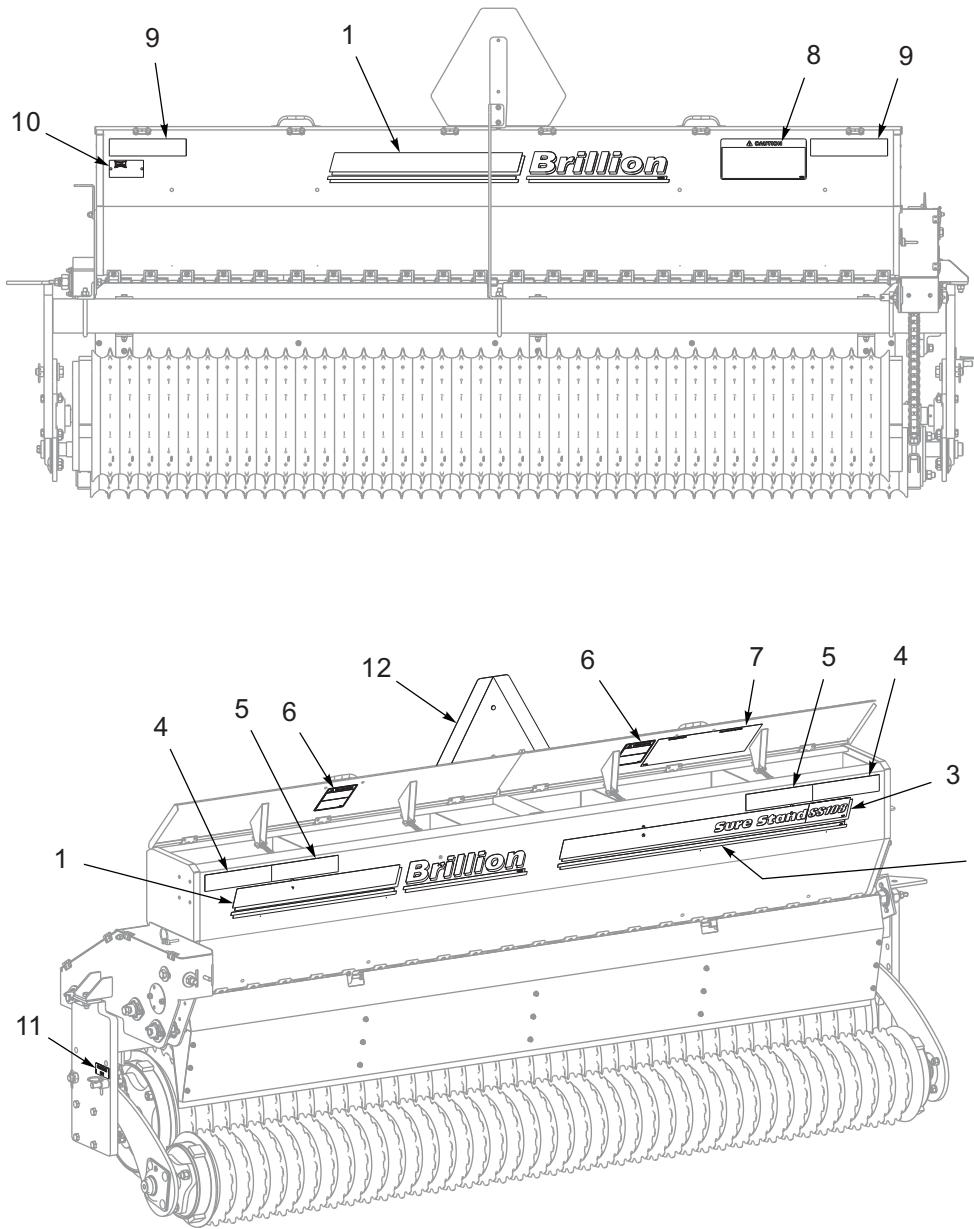


Figure 1-5: Decal Placement - 8FT Models



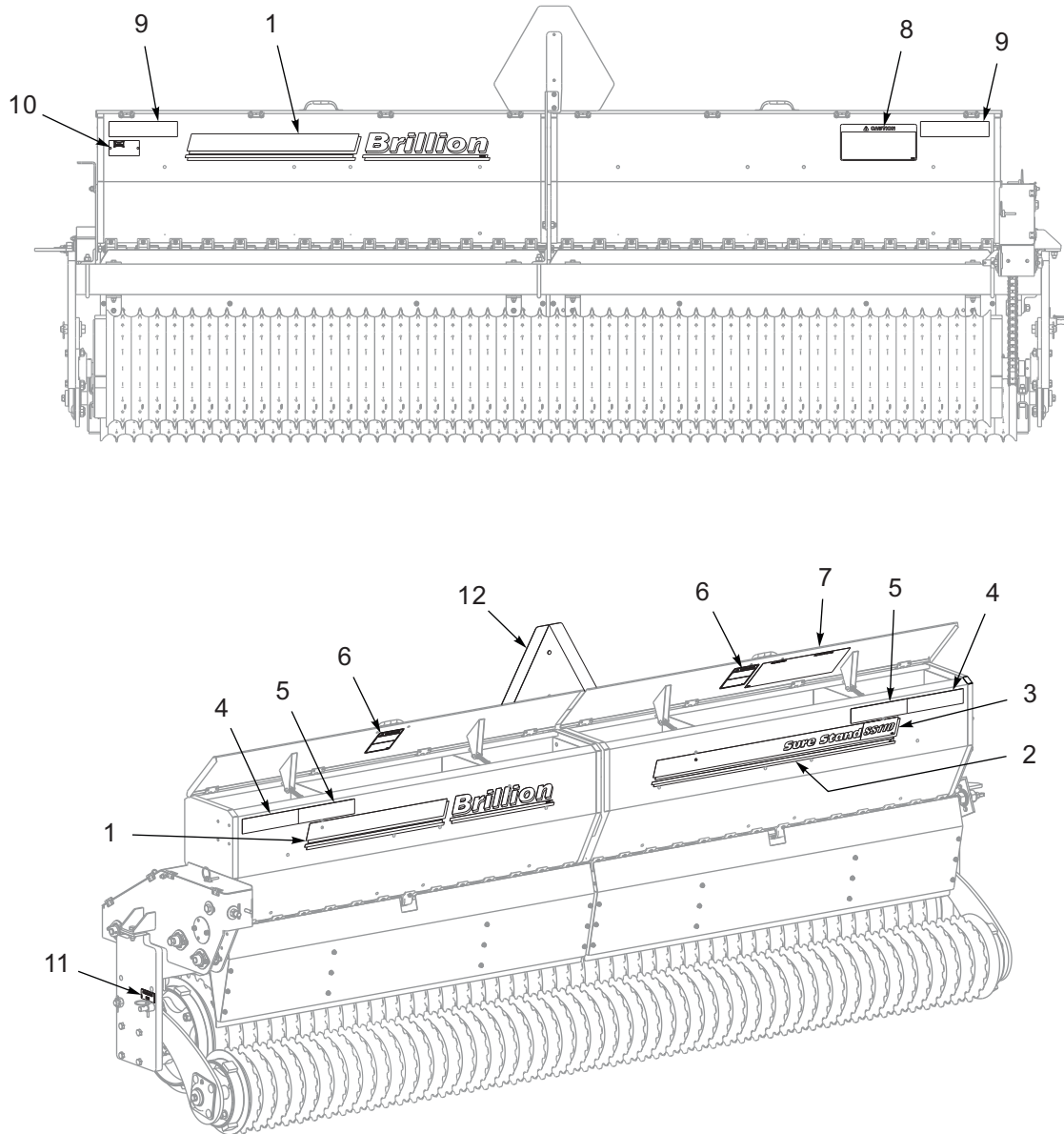


Figure 1-6: Decal Placement - 10FT Models



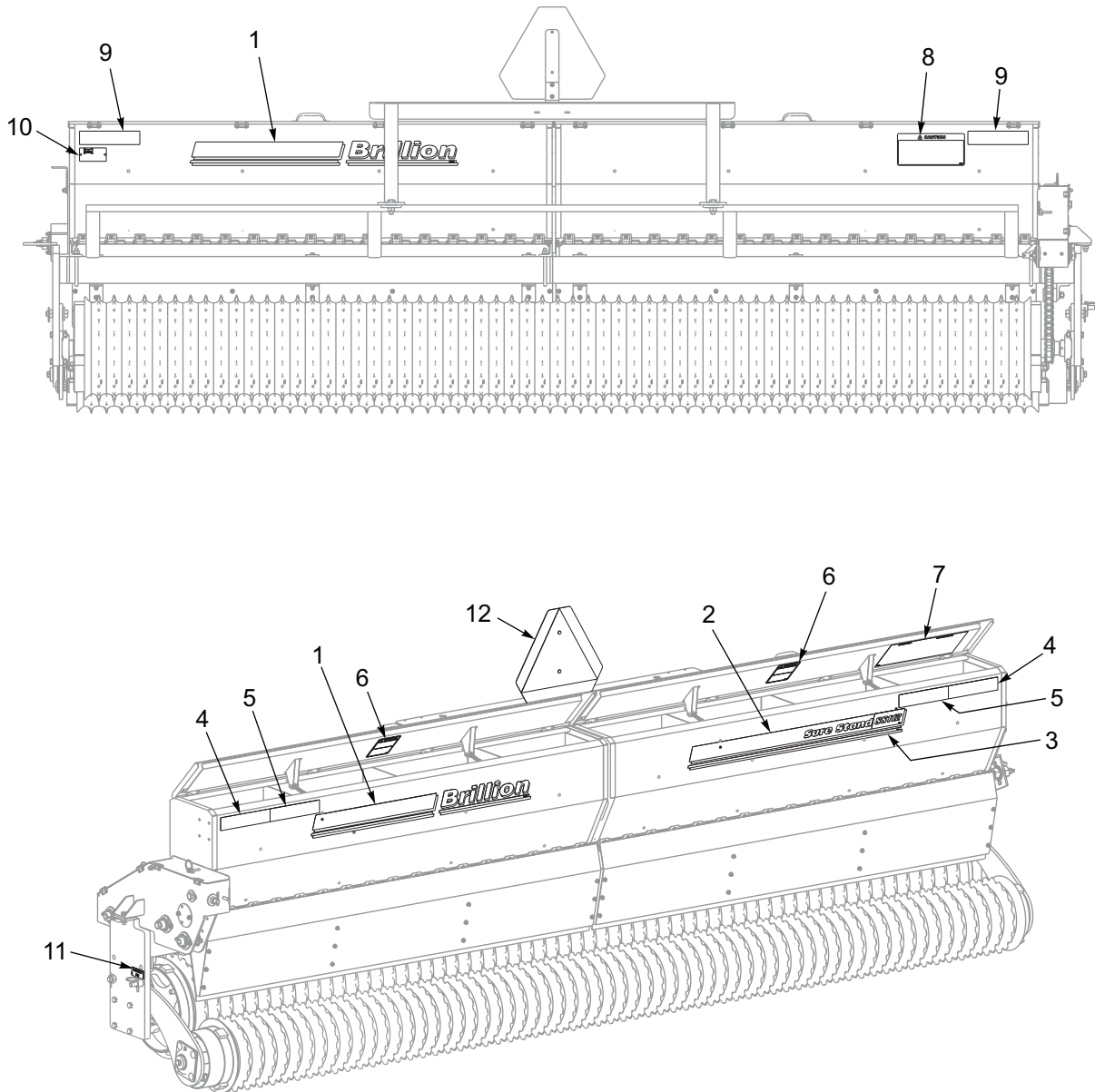


Figure 1-7: Decal Placement - 12FT Models



## Assembly

**CAUTION**

Do not work on or under this machine unless securely blocked and supported by a hoist or tractor or by other sufficient means.

**WARNING**

Do not attempt to lift heavy parts manually. Use a hoist or a fork lift to move these parts into position.

**NOTE**

Refer to the repair parts manual 9K712 for identification of parts and for the approximate relationship of the parts in assembly.

To ensure alignment of assemblies, leave the nuts loose until completion of final assembly. Use Lock Washers or Flat Washers as specified. Spread all cotter pins.

After completion of final assembly, tighten all nuts evenly to prevent misalignment, distortion or binding. Tighten all screws and nuts to the recommended torques.

**IMPORTANT**

- If a pre-assembled parts or fastener is temporarily removed, remember where they go. It is best to keep parts separated.
- Check that all working parts move freely, bolts are tight and cotter pins are spread.
- Park the seeder in a work area that has a level surface and make sure it is blocked securely so that it cannot roll.
- Refer to the Torque Table for proper torque values. Note the different torque requirements for Bolts with Locknuts. **See Page 4-1.**

“Left” and “Right” refer to directions seen as if standing behind the machine and facing in the direction of forward travel.

**IMPORTANT**

All harnesses must be firmly attached to machine frame members, so they don't sag or become torn loose by field debris. Use the tie wraps provided.

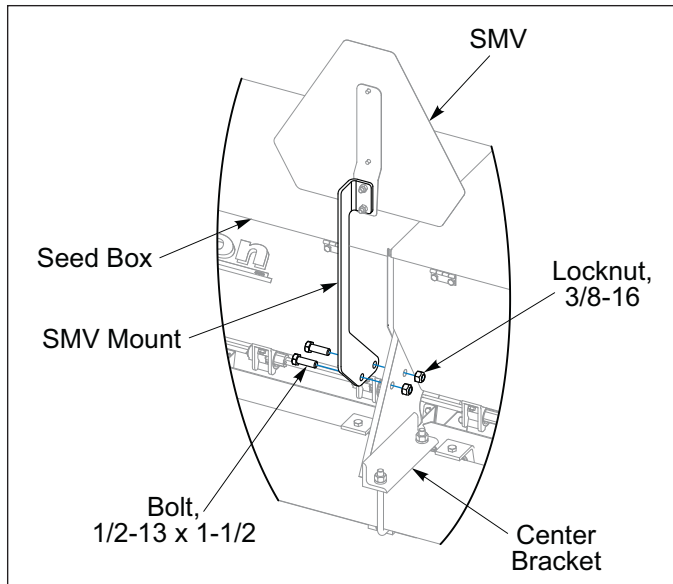
Check to be sure the harnesses at center of machine is slack enough so as not to be stretched or interfered with while rotating frame from transport to field working position and vice versa.

**ASSEMBLY**

**3-PT Seeder Assembly**

When shipped, seeder comes assembled except for Lights and 3-PT Hitch.

1. Support Seeder Assembly with a hoist or by similar means capable of supporting its weight without tipping.
2. Center 3-PT Hitch Assembly in relationship with the Seed Box Center Bracket. Attach 3-PT Hitch to Seeder Frame Tube with 5/8-11 U-Bolts, Lock Washers and Nuts. **See Figure 2-4.**
3. Install Manual Holder to 3-PT Hitch with Hose Clamps.
4. 8FT and 10FT Seeders, install SMV Mount to Seed Box Center Bracket with 1/2-13 x 1-1/2 Bolts and Locknuts. **See Figure 2-1.**

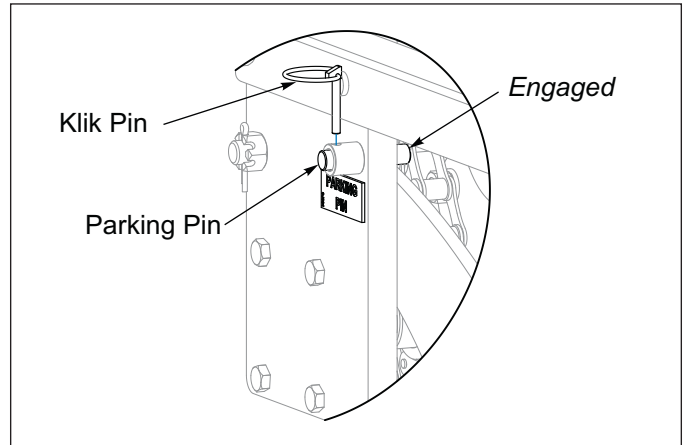


**Figure 2-1: SMV Mount**

**CAUTION**

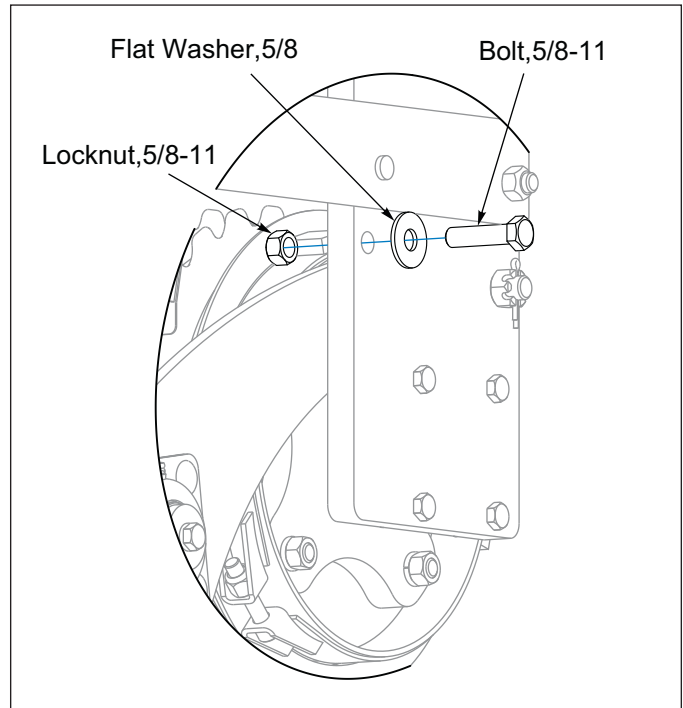
**Do not disengage pin unless seeder is fully attached to a tractor. Seeder may be rear-heavy and tip backward on frame.**

5. Be sure Parking Pin is locking Rear Roller down and raise the Seeder. **See Figure 2-2.**



**Figure 2-2: Parking Pin Engaged**

6. On the right side of the Seeder Frame, in a similar position as the Parking Pin, remove the 5/8-11 Shipping Bolt that also locks the Rear Roller down. **See Figure 2-3.**



**Figure 2-3: Shipping Bolt**

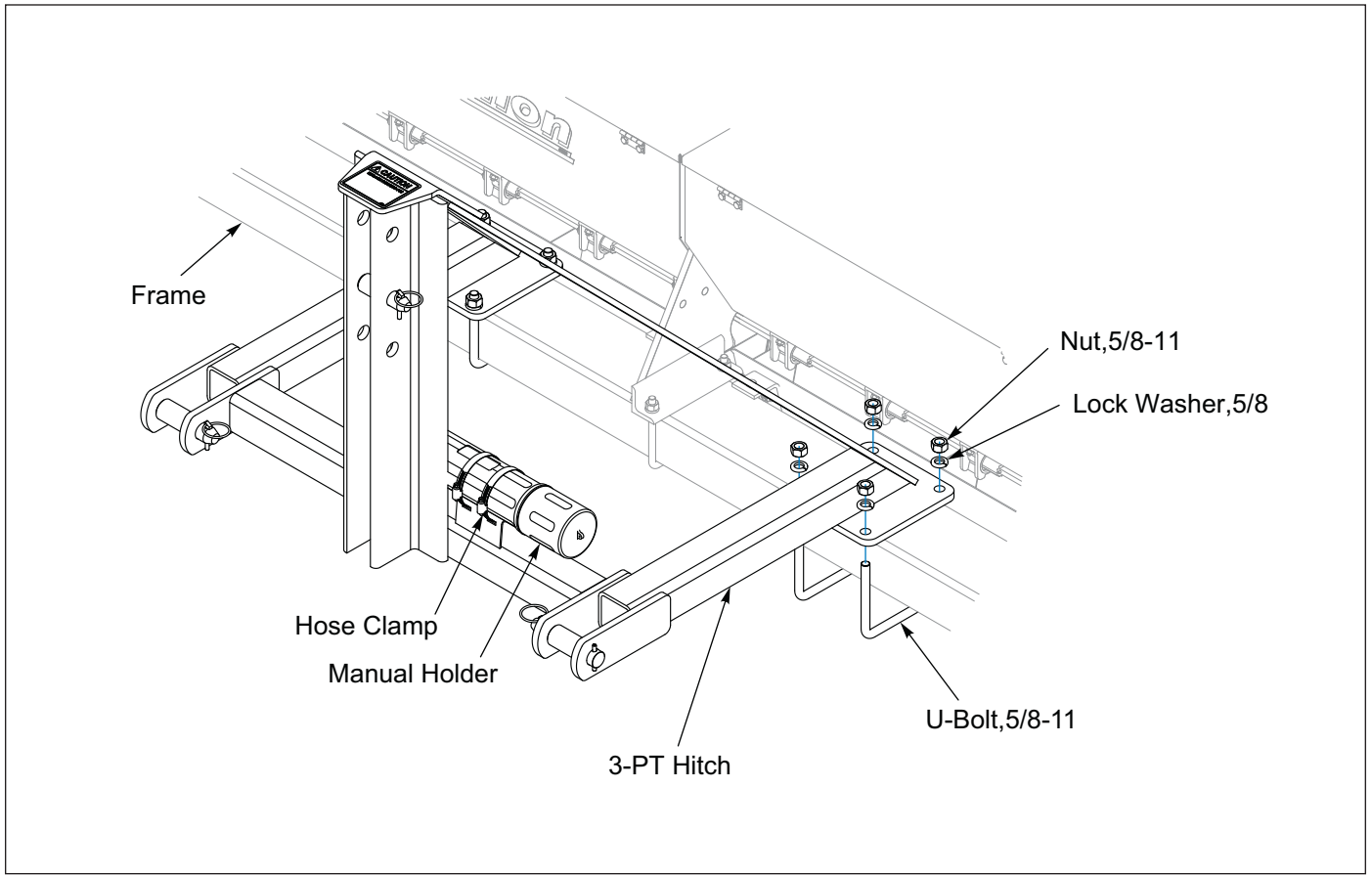
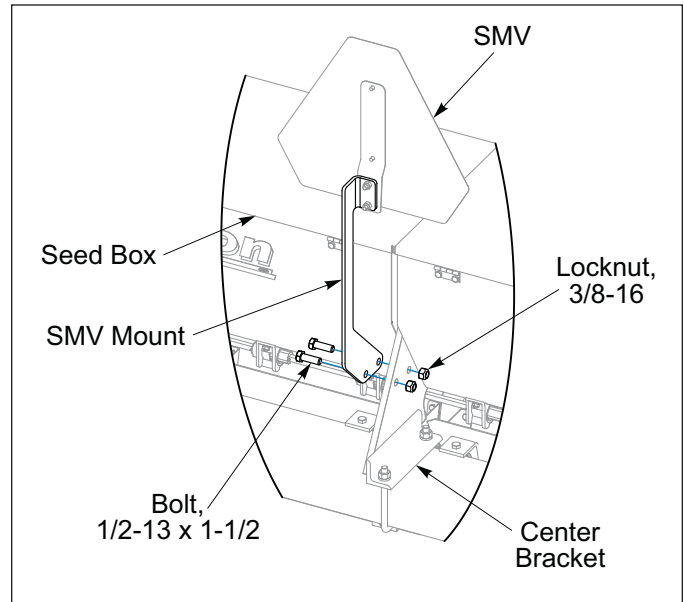


Figure 2-4: Attach 3-PT Hitch

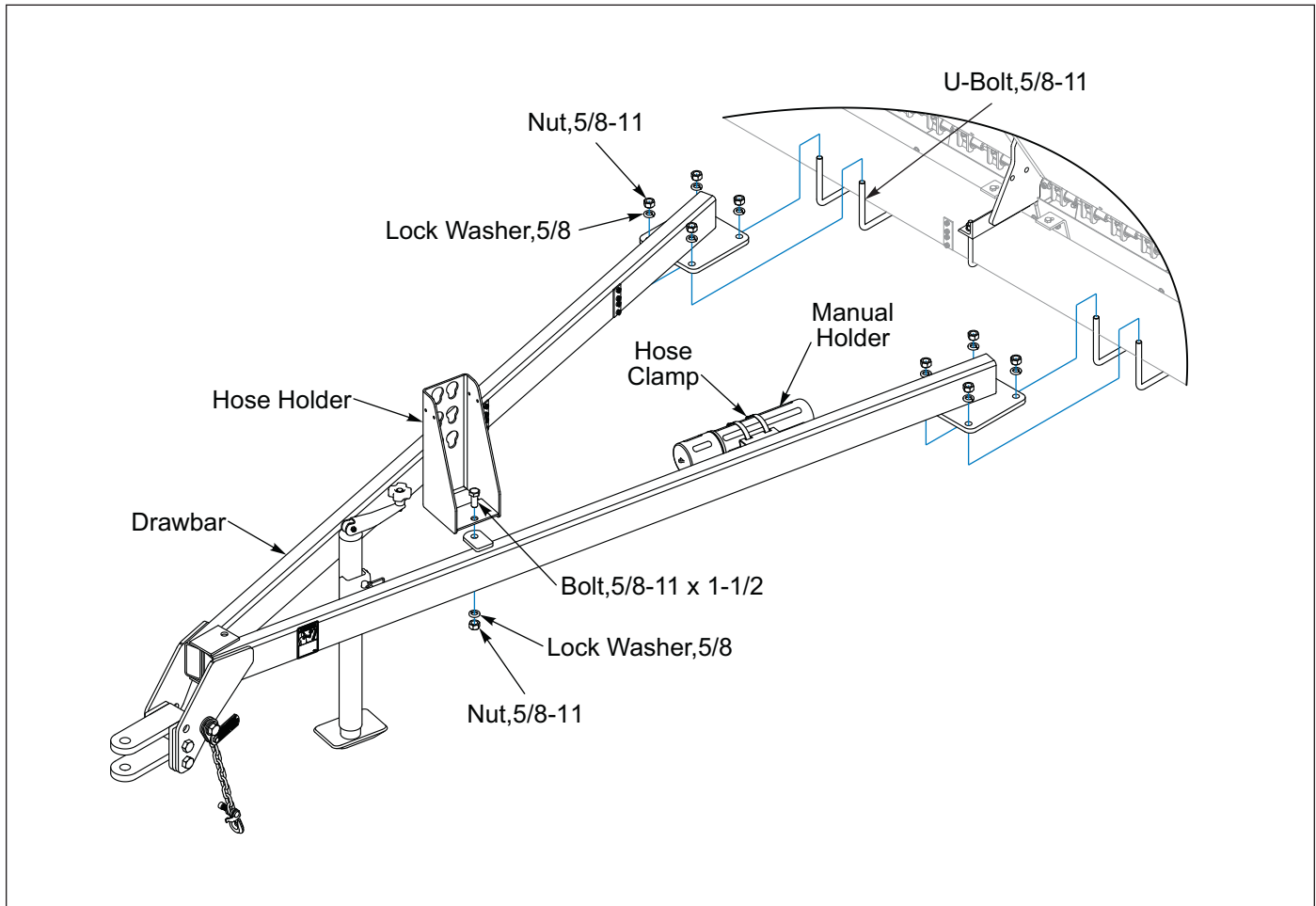
## Pull Type Seeder Assembly

When shipped, Seeder comes assembled except for Lights, Hub and Spindle Assemblies, Tire and Wheels Assemblies and Drawbar.

1. Untie the two rolled up Drawbar Hydraulic Hoses near the center of the Frame Tube. Ensure the hoses are not interfering with where the Drawbar is to be attached.
2. Center Drawbar in relationship with the Seed Box Center Bracket. Attach Drawbar to Seeder Frame Tube with 5/8-11 U-Bolts, Lock Washers and Nuts. **See Figure 2-6.**
3. Attach the Hose Holder to the Drawbar with 5/8-11 x 1-1/2 Bolt, Lock Washer and Nut.
4. Install Manual Holder to Drawbar with Hose Clamps.
5. 8 FT and 10 FT Seeders, install SMV Mount to Seed Box Center Bracket with 1/2-13 x 1-1/2 Bolts and Locknuts. **See Figure 2-5.**
6. Apply anti-seize to Spindles and insert a Hub and Spindle Assemblies into each Wheel Arm. Secure in Spindles farthest hole from the Hub with 1/2-20 x 1 Bolts and Locknuts. **See Figure 2-7.**



**Figure 2-5: SMV Mount**



**Figure 2-6: Drawbar Installation**

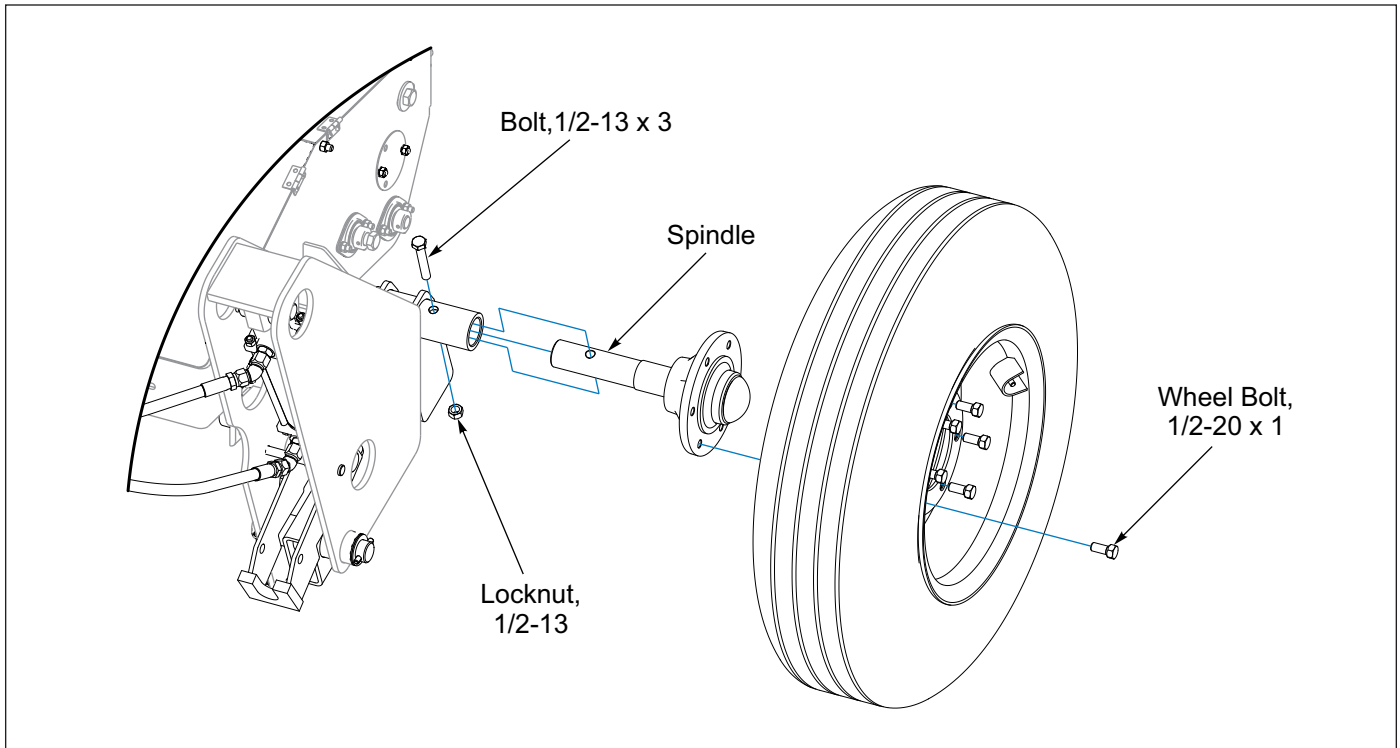


Figure 2-7: Spindle

## Tire and Wheel Installation



### WARNING

Use a torque wrench to assure proper torque. Insufficient torque can cause stud breakage and damage the wheel pilots. Over torque can stress the Bolts and strip the threads.

### NOTE

The tire/wheel assembly is mounted with the valve stem facing outward from Hub and Spindle.

### IMPORTANT

Torque will drop after the first 10 hours of operation. Check the Wheel Bolts for proper torque after this interval and re-tighten them

- The Seeder uses 9.5L-15, 8 Ply Rating Tires and should be inflated to 44 PSI.
- Install a Tire and Wheel Assembly onto each Hub with 1/2-20 x 1 Wheel Bolts and tighten the Wheel Bolts to 50 Ft-Lbs. using the sequence in **Figure 2-8**. Then tighten to a full torque of 80-85 Ft-Lbs.

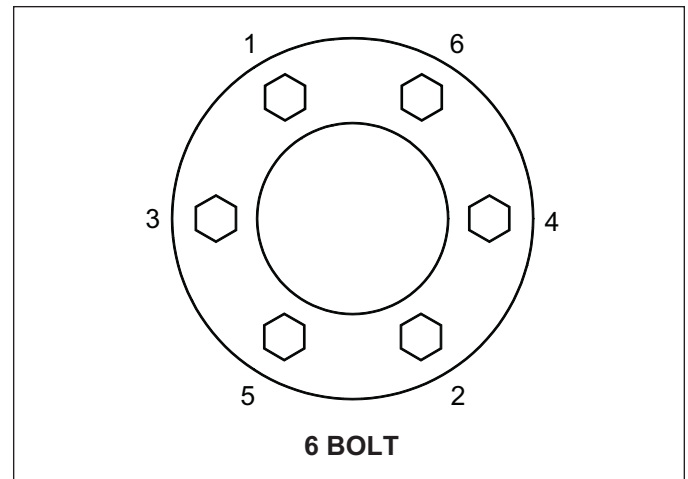


Figure 2-8: Tightening Sequence

# Hydraulic Installation



## WARNING

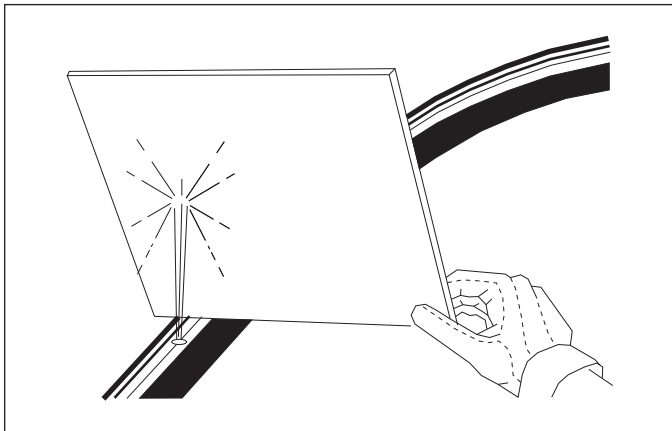
Escaping fluid under pressure can be nearly invisible and have enough force to penetrate the skin causing serious injury. Using a piece of cardboard, rather than your hands, to search for suspected leaks. (See Figure 2-9.) Wear protective gloves and safety glasses or goggles when working with hydraulic systems.

### Tightening Procedure for JIC 37 degree Swivel Female Nuts.

1. Check Fitting Flare and seat for defects.
2. Lubricate the connection.
3. Install Hydraulic Hoses without twists.
4. Hand Tighten until connections bottoms.
5. Using 2 wrenches to prevent twisting, rotate the Swivel Nut 2 wrench flats (1/3 turn).
6. For reassembly, follow the same procedure but tighten only 1 wrench flat (1/16 turn).

### Tightening Procedure for Swivel O-Ring Fittings.

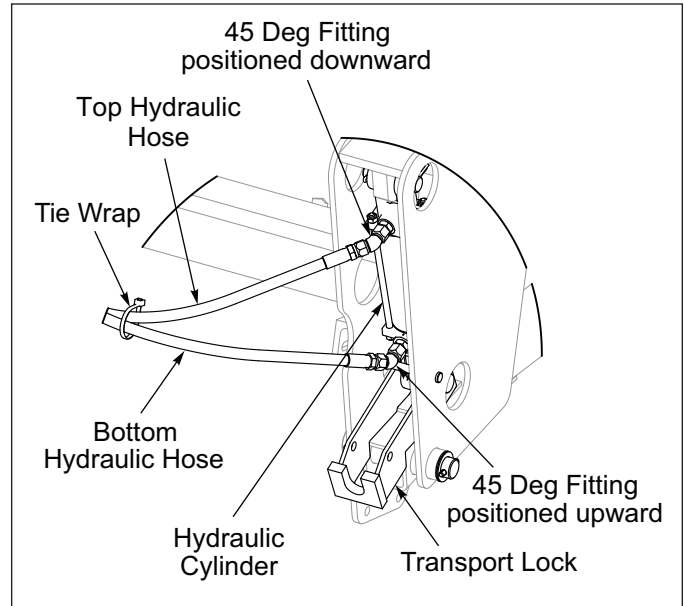
1. Lubricate O-Ring and install the Fitting until the Metal Washer which backs up the O-Ring contacts the face of the boss.
2. Orient the Fitting by turning counterclockwise up to 1 turn.
3. Tighten the Locknut using 50-60 Ft-Lbs of torque. See "Hydraulic Fitting Torque Specifications" on Page 4-2.



**Figure 2-9: Leak Detection**

## Hydraulic Assembly

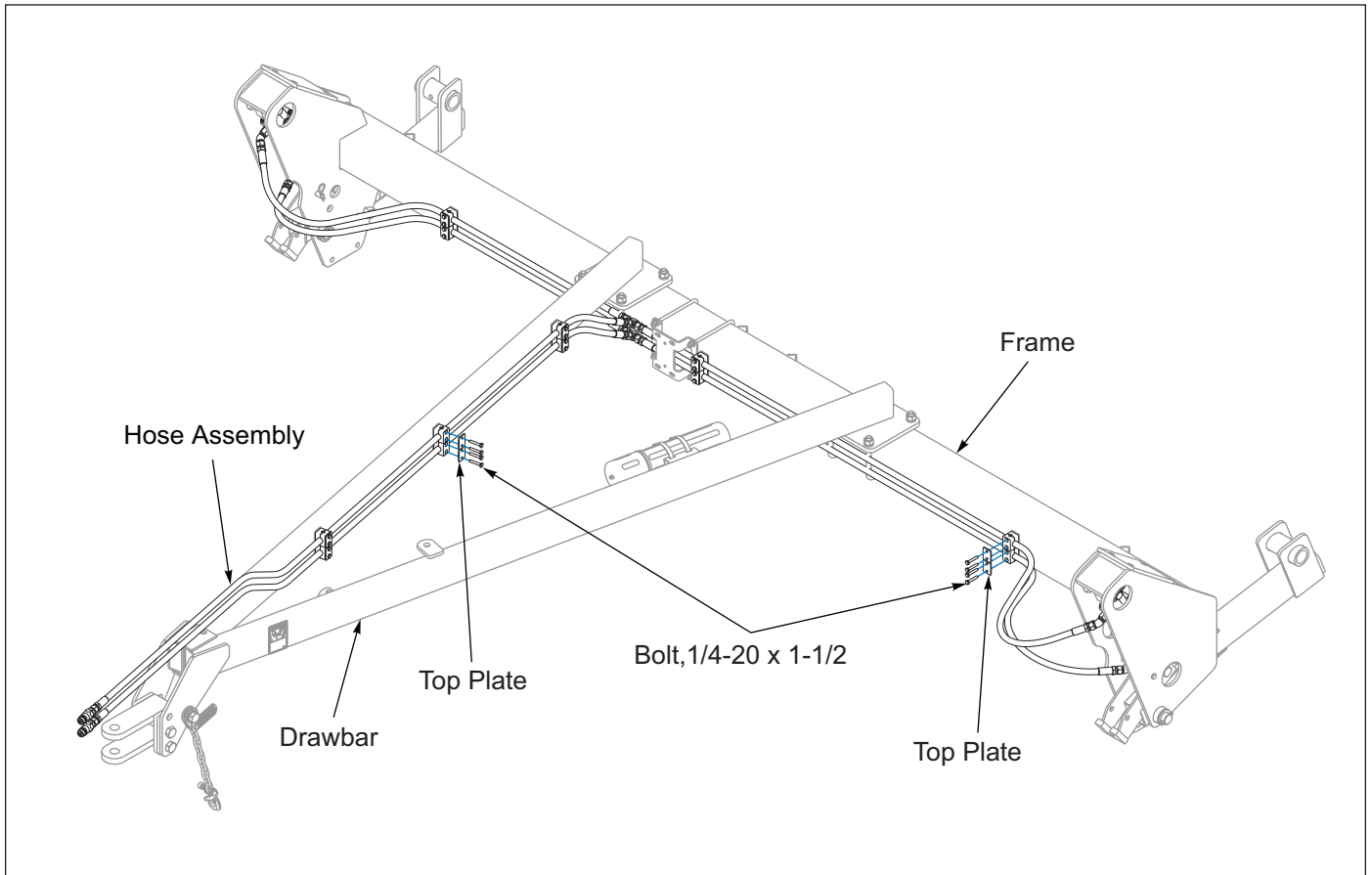
1. Restrictors installed in Cylinder Ports, connect 45 Degree Fitting so they are free to swivel. Connect top Hydraulic Hose to the Cylinder Base and bottom Hydraulic Hose to the Cylinder Rod End. Position the Hydraulic Hoses so that the Cylinder Base End points downward and the Cylinder Rod End points upward. Merge Hydraulic Hoses together and Tie Wrap them together about 12 inches from the Hose End. See **Figures 2-10 and 2-11**. Be sure that the Hoses cannot sag and make contact with the Front Roller Wheels.



**Figure 2-10: Cylinder Fittings Positioning**

2. Route the Drawbar Hydraulic Hoses along Drawbar toward the Tractor. Secure Hoses to Drawbar with Hose Clamp Pairs, Top Plate and 1/4-20 x 1-1/2 Bolt. See **Figure 2-11**.





**Figure 2-11: Drawbar Hydraulic Hoses**

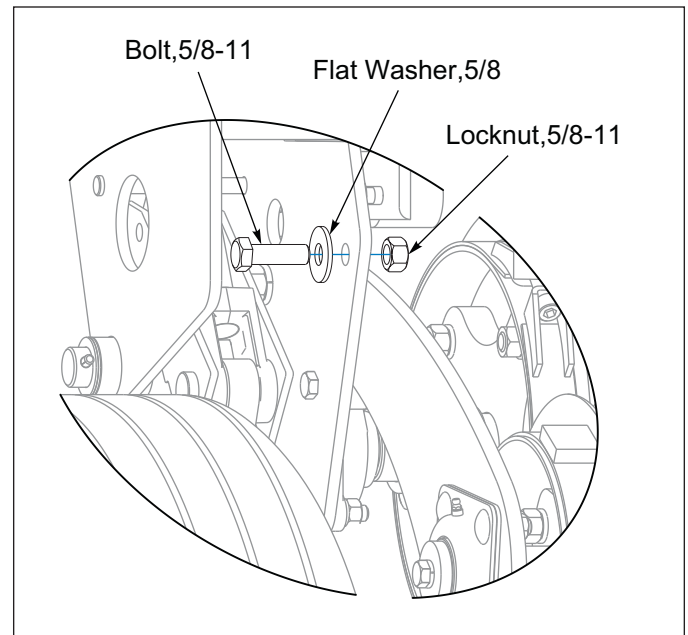


## Purge the Hydraulic Lift System

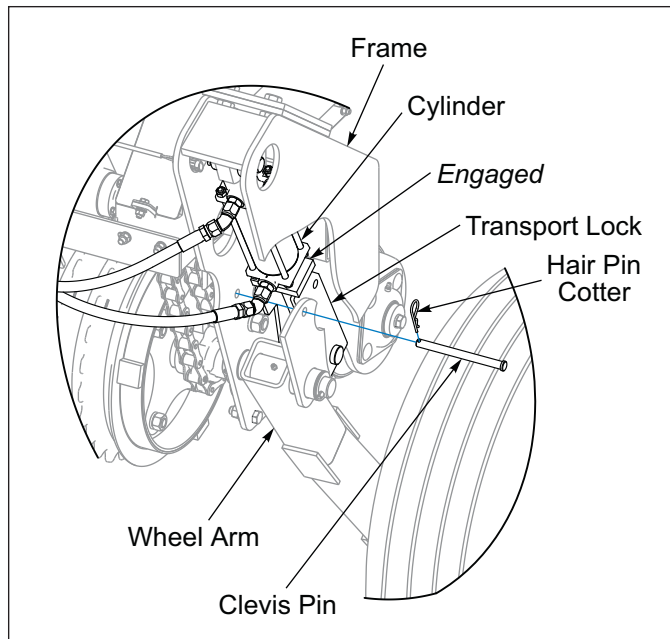
The Hydraulic system is not filled with oil and should be purged of air before transporting and field operations.

**Lift Circuit approximate oil requirement: 0.4 gallons.**

1. Carefully Hitch the Seeder to the Tractor and connect the Hydraulic Lift Hoses.
2. Check to make sure the tractor hydraulic reservoir is full of the manufacturer's recommended oil.
3. Slowly raise the machine until both Lift Cylinders are fully extended. Lower and raise the Seeder to verify that both Cylinders are working throughout the stroke. Fully extend the Lift Cylinders and continue to hold the lever until both Cylinder Rod movement stops. Raise/Lower Seeder 5 times to purge air from the system.
4. Do Not loosen any Hydraulic Hoses or Fittings.
5. Recheck Tractor Reservoir to make sure it is within operating limits.
6. Raise the Seeder and install Transport Locks. **See Figure 2-12.**
7. Remove from the RH and LH Frame End Plate the 5/8-11 Shipping Bolts that locks the Rear Roller Arms Down. **See Figure 2-13.**



**Figure 2-13: Shipping Bolt**



**Figure 2-12: Transport Lock Engaged**

## Warning Lamp Installation, 8FT and 10FT

**NOTE**

8FT 3-PT Model is shown, 8FT Drawbar, 10FT 3-PT and 10FT Drawbar models similar.

1. Attach longer Light Bracket to the Transmission housing located on the left side of the Seeder, with 3/8-16 x 1-1/4 Bolts, Lock Washers and Nuts.
2. Attach Amber Lamp to the upper portion of the longer Light Bracket with 1/4-20 x 1-1/4 Bolts and Locknuts.
3. Attach a Red Lamp below the Amber Lamp with 1/4-20 x 1 1/4 Bolts and Locknuts. Ensure Red Lamp lenses faces rearward. **See Figure 2-15.**
4. On the right side of the Seeder attach the shorter Light Bracket to the Angle Bracket with 1/2-13 x 1-1/4 Bolts, Lock Washers and Nuts.
5. Attach Amber Lamp to the upper portion of the Light Bracket with 1/4-20 x 1-1/4 Bolts and Locknuts.
6. Attach a Red Lamp below the Amber Lamp with 1/4-20 x 1-1/4 Bolts and Locknuts. Ensure Red Lamp lenses faces rearward.
7. Attach the Light Module to the Module Bracket with 1/4-20 x 1-1/2 Bolts and Locknuts. **See Figure 2-14.**
8. Lay out the Lamp Harness, noting that the connectors marked with Green Tape is Right Side and Yellow Tape is Left Side.
9. Connect the Lamp Harness into the Light Module, route the plugs with Green Tape along the front right side of the frame up the outer Light Bracket and plug the 2 prong cord into the Amber Lamp. Plug the 3 prong cord into the Red Lamp.
10. Repeat for the Left Side (Yellow Tape).
11. Connect the 7-Pin Harness into the Light Module, then route the Harness along the 3-PT Hitch.
12. Bundle and secure excess cord to the Module Bracket with tie wraps. Secure cords along frame and 3-PT Hitch using Adhesive Mounts and tie wraps.

**NOTE**

If equipped with optional Electrical Clutch, install, route and secure Electric Clutch Harness with the Warning Lamp Harness.

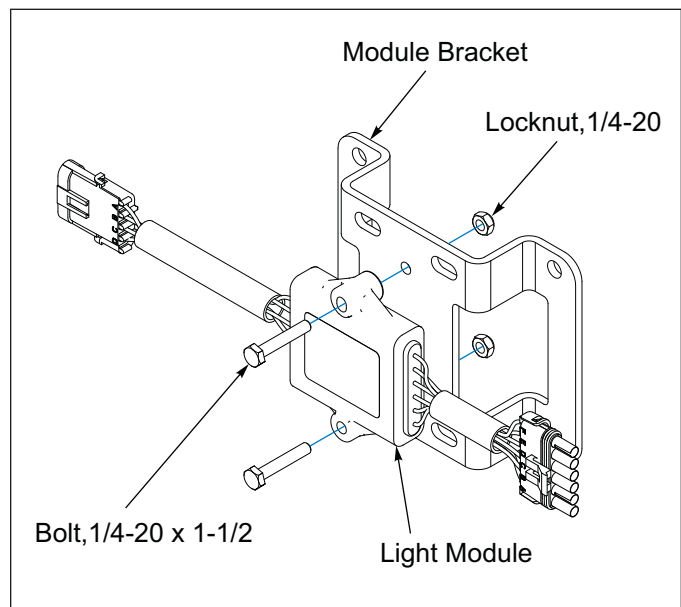
**IMPORTANT**

All wires must be firmly attached to Machine Frame members or Hydraulic Hoses so they do not sag or become torn loose by field debris.

13. Attach the SMV sign to the SMV Mount located on the center on the Front Frame with 5/16-18 x 1 Bolts, Flat Washers, and Locknuts.
14. Attach the Connector Holder to the Drawbar Hose Holder or 3-PT Hitch with 1/4-20 x 1 Bolts, Flat Washers, and Locknuts.

**NOTE**

The 7-Pin Plug on the other end of the 7-Pin Harness connects to the Tractor Socket when in use. When not in use, it can be stored in the Connector Holder on the Drawbar Hose Holder or 3-PT Hitch. Allow enough harness length to reach Tractor Socket and roll or fold up excess and secure to Drawbar Hydraulic Hoses or 3-PT Hitch.



**Figure 2-14: Light Module and Bracket**

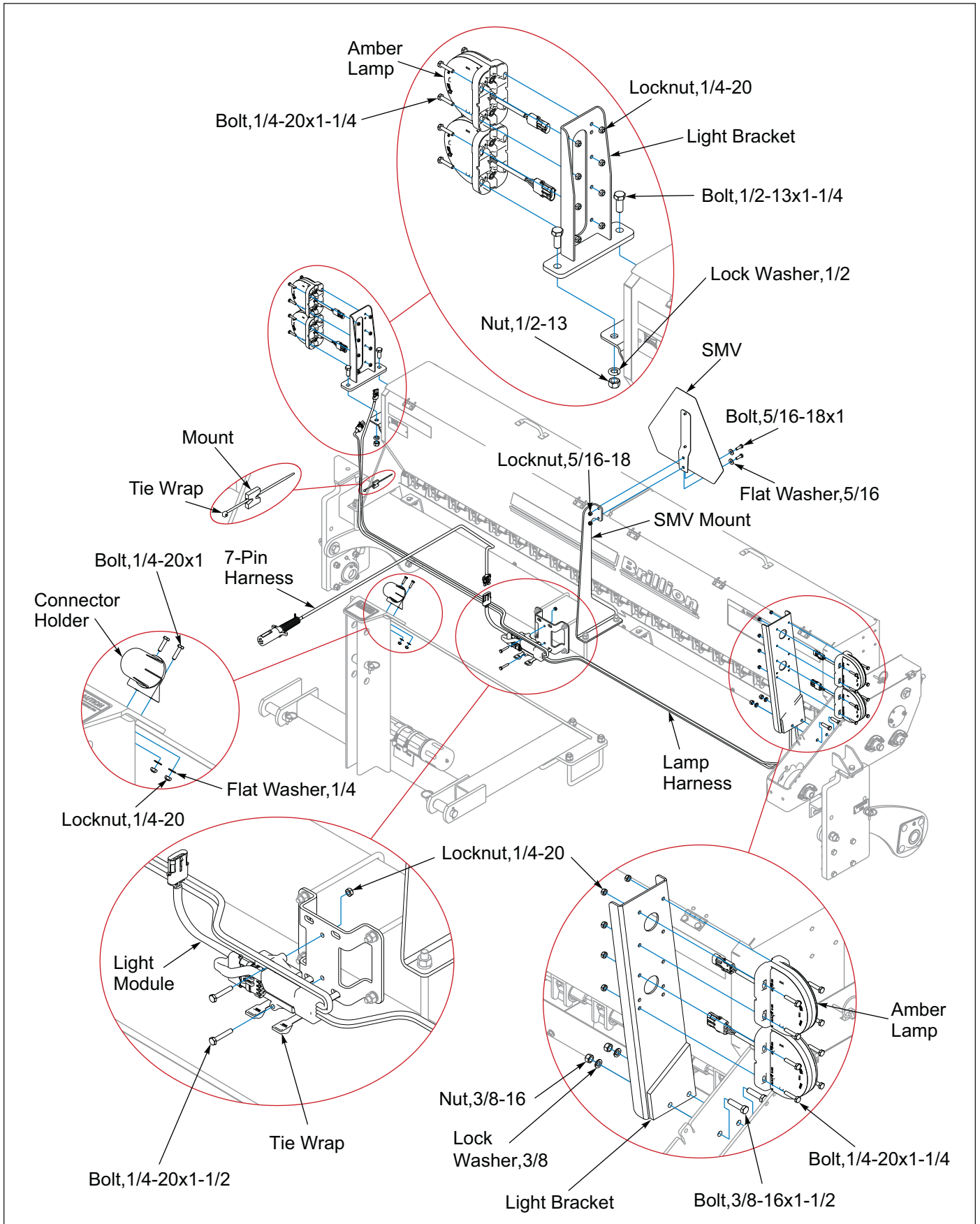


Figure 2-15: Warning Lamps Installation, 8FT and 10FT

## Warning Lamp Installation, 12FT

**NOTE**

*12FT Drawbar model is shown, 3-PT models similar.*

1. Attach both Red Lamps to the ends of the Light Bar with 1/4-20 x 1 1/4 Bolts and Locknuts.
2. Attach longer Light Bracket to the Transmission located on the left side of the Seeder, with 3/8-16 x 1 1/4 Bolts, Lock Washers and Nuts.
3. Attach Amber Lamp to the outside of the Light Bracket with 1/4-20 x 1 1/4 Bolts and Locknuts. **See Figure 2-17.**
4. On the right side of the seeder, attach the shorter Light Bracket to the Angle Bracket with 1/2-13 x 1-1/4 Bolts, Lock Washers and Nuts.
5. Attach an Amber Lamp to the upper portion of the Light Bracket with 1/4-20 x 1-1/4 Bolts and Locknuts.
6. Attach the Light Module to the Module Bracket with 1/4-20 x 1-1/2 Bolts and Locknuts. **See Figure 2-16.**
7. Lay out the Lamp Harness, noting that the connectors marked with Green Tape is Right Side and Yellow Tape is Left Side.
8. Connect the Lamp Harness into the Light Module, route the plugs with Green Tape along the front right side of the frame. Route the 3 prong cord up the Light Bar and plug into the Red Lamp. Continue routing the 2 prong cord along the front of frame, up the outer Light Bracket and plug it into the Amber Lamp.
9. Repeat for the Left Side (Yellow Tape).
10. Connect the 7-Pin Harness into the Light Module, then route the Harness along the drawbar with the Hydraulic Hoses and secure with tie wraps.
11. Bundle and secure excess cord to the Module Bracket with tie wraps. Secure cords along frame and drawbar using Adhesive Mounts and tie wraps.

**NOTE**

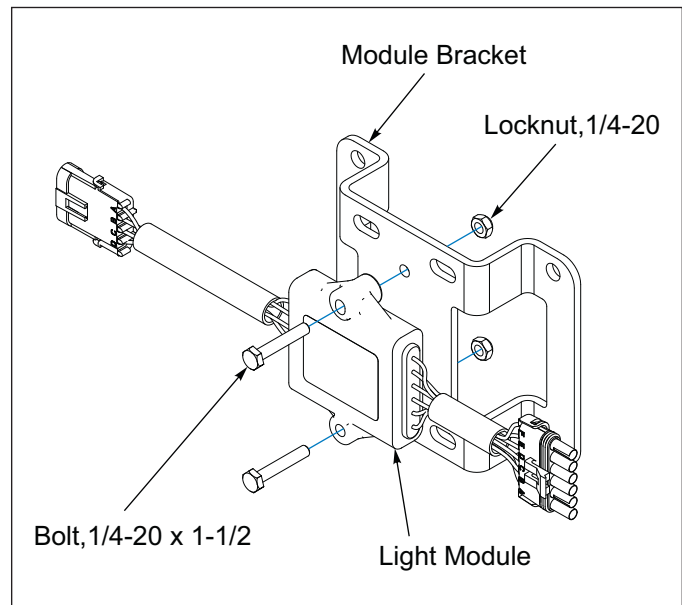
*If equipped with optional Electrical Clutch, install, route and secure Electric Clutch Harness with the Warning Lamp Harness.*

**All wires must be firmly attached to Machine Frame members or Hydraulic Hoses so they do not sag or become torn loose by field debris.**

12. Attach the SMV sign to the SMV Mount located on the center on the Light Bar with 5/16-18 x 1 Bolts, Flat Washers, and Locknuts.
13. Attach the Connector Holder to the Drawbar Hose Holder or 3-PT Hitch with 1/4-20 x 1 Bolts, Flat Washers, and Locknuts.

**NOTE**

*The 7-Pin Plug on the other end of the 7-Pin Harness connects to the Tractor Socket when in use. When not in use, it can be stored in the Connector Holder on the Drawbar Hose Holder or 3-PT Hitch. Allow enough harness length to reach Tractor Socket and roll or fold up excess and secure to Drawbar Hydraulic Hoses or 3-PT Hitch.*



**Figure 2-16: Light Module and Bracket**

**IMPORTANT**

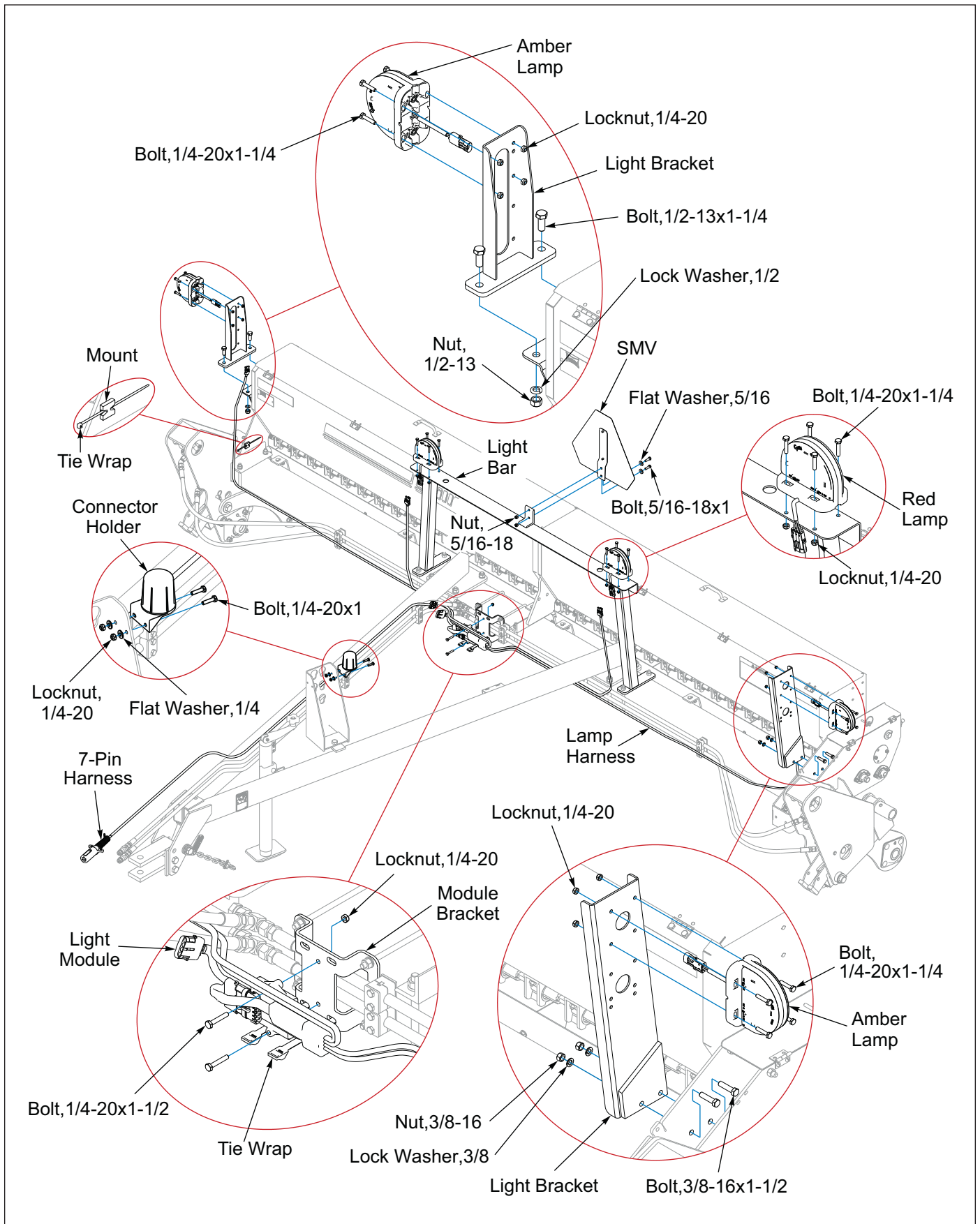


Figure 2-17: Warning Lamp Installation, 12FT





## Electric Clutch Kit - Optional

### IMPORTANT

At no time use high pressure water or air to clean the Electric Clutch as damage could occur.

1. Verify that the Electric Clutch has 1/8" clearance between the Clutch Housing and Rubber Bumper Stop. Improper clearance may prevent the Clutch from engaging or disengaging. **See Figure 2-18.**
2. Connect Clutch Harness to Clutch Lead and route along Frame and Drawbar/3-PT Hitch. Secure to Frame and Drawbar/3-PT Hitch or with Hydraulic Hoses and Warning Lamp Harness with tie wraps and Adhesive Mounting Plates. **See Figure 2-19.**
3. Install Clutch Switch on Tractor in a convenient location with the Hook and Loop included or other type of mount (not included).
4. Connect Harness to power source and secure.
5. Check Electric Clutch Operation. The Electric Clutch will disengage when power is applied. (Clutch will make a clicking sound). Set Seeder on the ground and drive a short distance while turning Toggle Switch to "Seed" and "No Seed". The Seed Shaft will stop rotating when Toggle Switch is turned to "No Seed" Position.
6. Turn Toggle Switch to "Seed" Position when Seeder is not used to shut off power to prevent possible overheating of Clutch Coil.

### Electric Clutch Attributes:

- The Electric Clutch is controlled by a Toggle Switch on the Clutch Switch Box that is mounted to the Tractor.
- The Electric Clutch is disengaged when power (12 Volts) is applied. If there is a power failure or electrical problem, the Seeder will continue to operate, so the machine must be raised to stop seeding.
- Seed Shafts will not rotate when the machine is backed up.
- The Clutch Switch Box contains a 5 Amp Time-Delay Fuse.
- The Electric Clutch must be disengaged (power applied) when Seed Shafts are turned manually for Calibration.

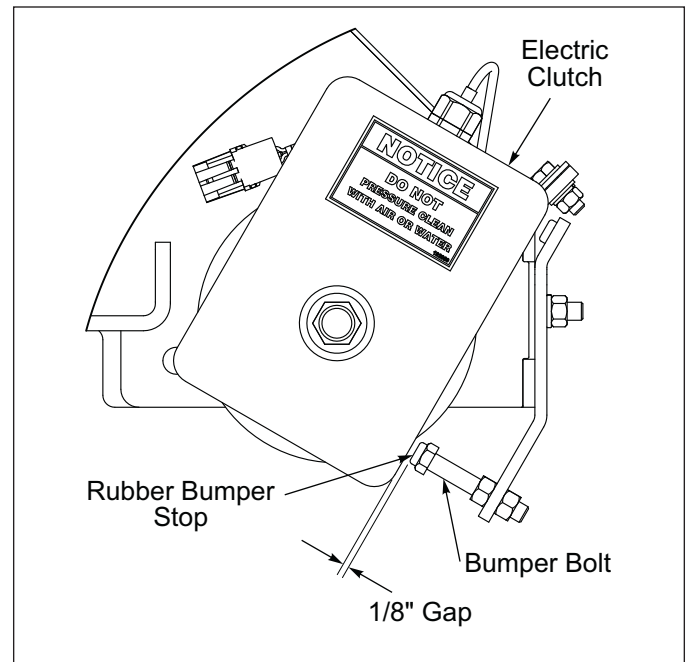


Figure 2-18: Clutch Clearance

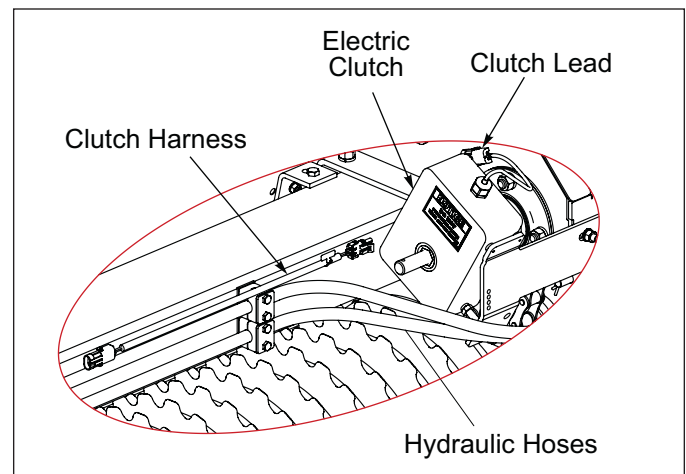


Figure 2-19: Clutch Harness

**Acre Meter Kit - Optional**

P/N 5K745 - Transmission w/o Clutches

P/N 5K275 - Transmission w/ Clutches

**NOTE**

The Acre Meter Kit consists of three main parts, the Acre Meter, the Pick-Up Switch and the Magnet Wheel Assembly. The Acre Meter Assembly is mounted on the left side of the Front Seed Box.

**IMPORTANT**

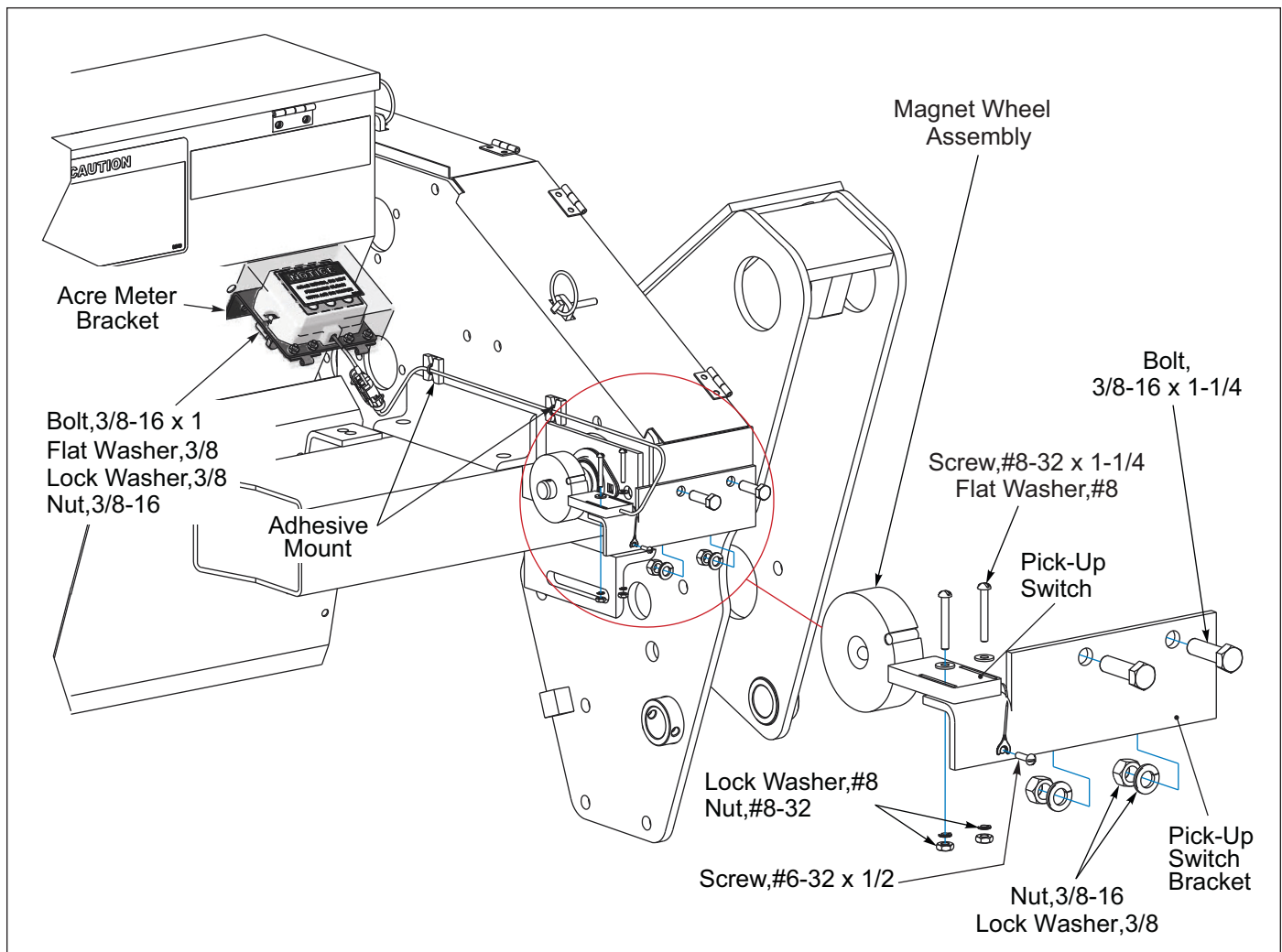
**Alignment of the Pick-Up Switch and the Magnet Wheel Assembly is critical. Improper alignment will cause the Acre Meter to record acres erratically or not at all.**

1. Use the Acre Meter Bracket as a guide and drill two 13/32" holes into the left Seed Box.
2. Attach the Acre Meter Bracket to the Seed Box with 3/8-16 x 1 Bolts, Flat Washers, Lock Washers and Nuts. See Figure 2-20.

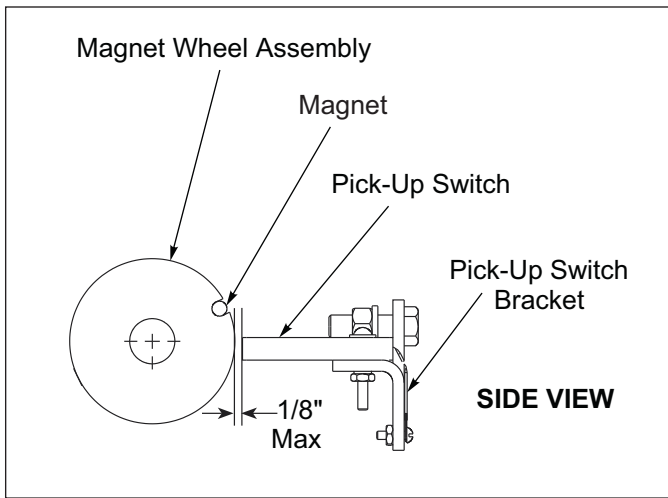
3. **Transmission w/o Clutch:** Attach the Pick-Up Switch Bracket to the front of the Transmission with 3/16 x 1-1/4 Bolts, Lock Washers and Nuts.

**Transmission w/ Clutch - Optional:** Attach the Pick-Up Switch Mount to the Clutch Bracket with #10-24 x 3/4 Screws, Lock Washers and Nuts. See Figure 2-22.

4. Attach the Pick-Up Switch to the top of the Pick-Up Switch Bracket/Mount with two #8-32 x 1-1/4 Machine Screws, Flat Washers, Lock Washers and Nuts. Do not tighten Screws at this time.
5. Press the Magnet Wheel Assembly onto the Transmission Shaft until it is vertically centered with the Pick-Up Switch.
6. Adjust the Pick-Up Switch and Pick-Up Switch Bracket so the centerline of the Magnet Wheel Assembly and Pick-Up Switch are horizontally and vertically aligned with maximum 1/8" between the Magnet Wheel Assembly and Pick-Up Switch. Tighten all Screws. See Figures 2-21 and 2-22.

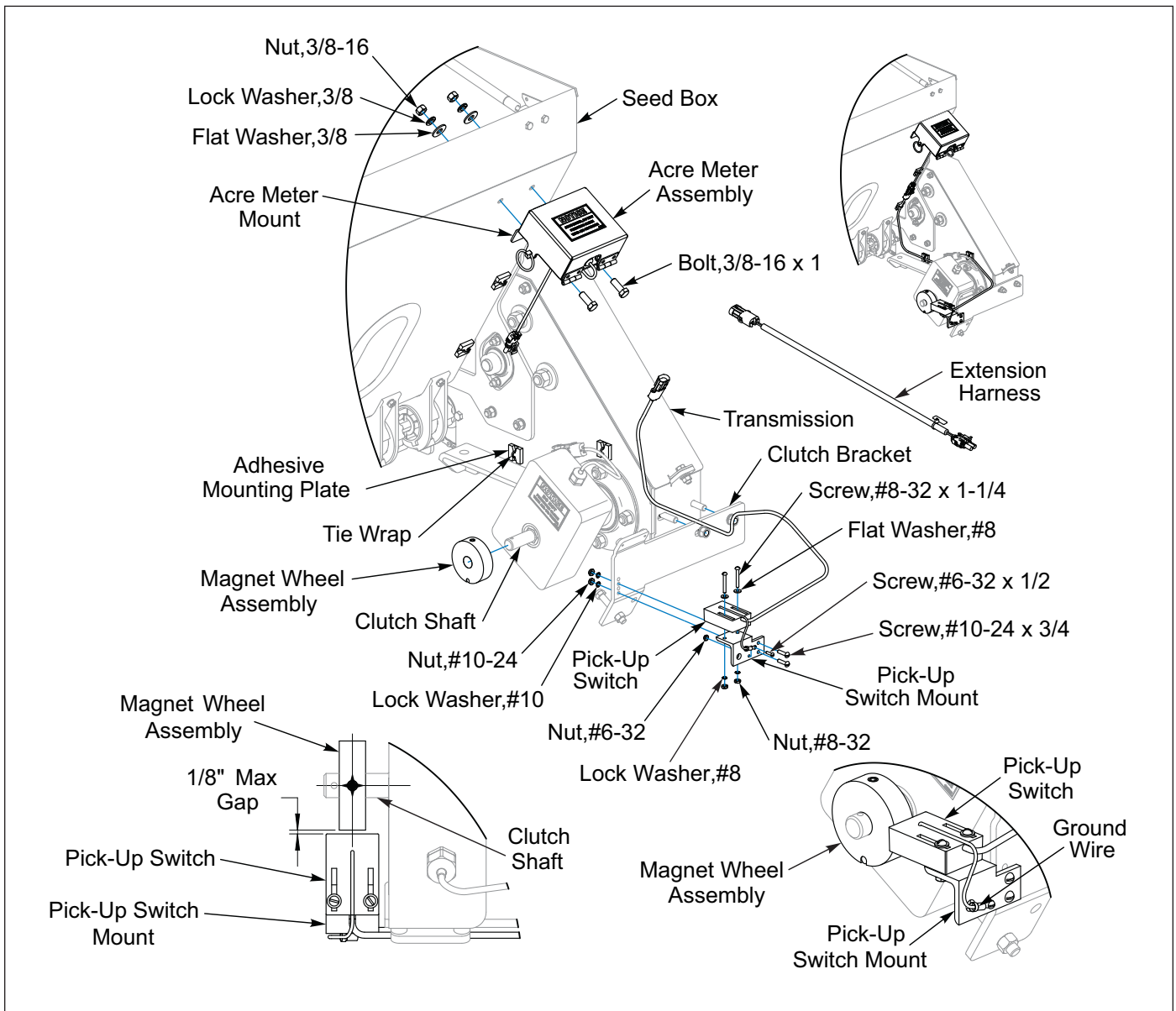


**Figure 2-20: Electronic Acre Meter**



**Figure 2-21: Pick-Up Switch Positioning**

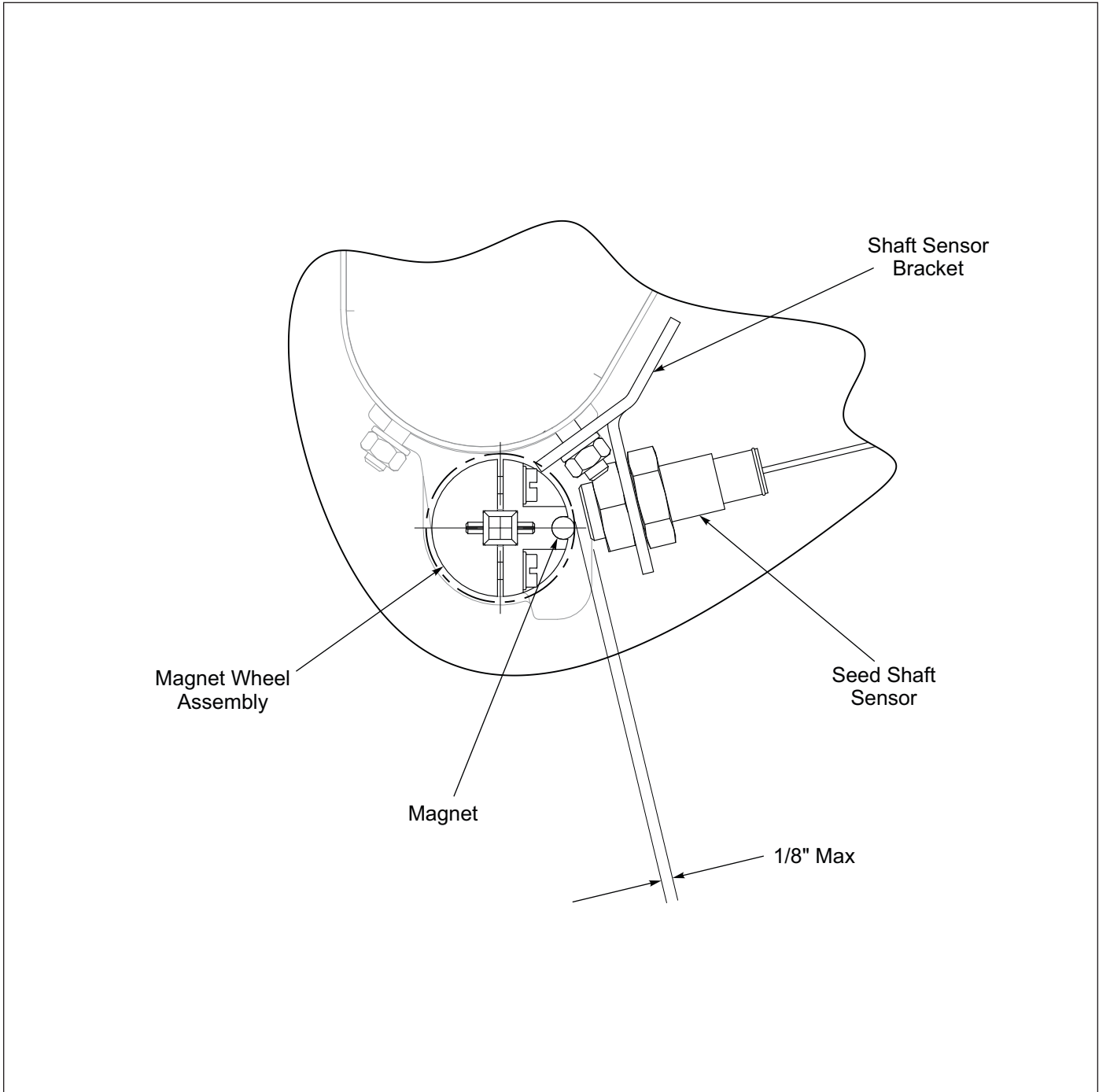
7. Attach the Pick-Up Switch Ground Wire to the small hole in the Pick-Up Switch Mount with a #6-32 x 1/2 Screw, removing paint under the wire connector to assure a good electrical ground connection.
8. Plug the Extension Harness into the Acre Meter Cord.
9. Route the cord from the Acre Meter down the front of the Seed Box to the Pick-Up Switch and connect the mating plugs.
10. Securely fasten the wire to the Seed Box and Transmission with the Adhesive Mounting Plates and tie wraps to prevent the Cords from becoming entangled or rubbing moving parts.
11. Program the Acre Meter. See "Transmission Drive Bolt" on Page 3-10.



**Figure 2-22: Electronic Acre Meter w/Clutch**

**Seed Shaft Sensor Kit - Optional**

1. Remove the two 10 x 24 x 3/4 self tapping screws from the Magnet Wheel Assembly. Position the rounded half of the Magnet Wheel Assembly on the seed shaft. Ensure it fits squarely onto shaft. Mount magnet half to the rounded half. ensure it fits squarely onto shaft.
2. Fasten the two halves together using two #10-24 x 3/4 Self Tapping Screws. *Do not over tighten.*
3. Identify the seed cups on either side of the Magnet Wheel Assembly and remove the 1/4-20 hardware.
4. Insert Sensor into Shaft Sensor Bracket slot.
5. Insert a 1/4-20 x 3/4 Machine Screw into each seed cup. Align the Shaft Sensor Bracket with the two 1/4-20 x 3/4 Screws. Secure with existing Lock Washers and Nuts.
6. Slide/Position Seed Shaft Sensor so it is 1/8" from the magnet. **See Figure 2-23.** Tighten both Retaining Locknuts.



**Figure 2-23: Seed Shaft Sensor Mounting Dimensions - Seed Meter**

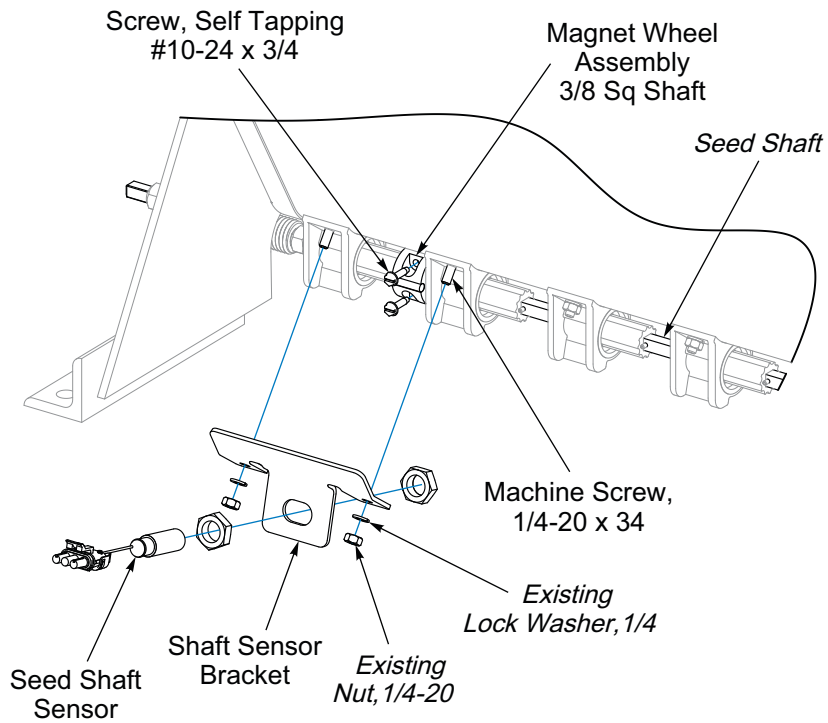
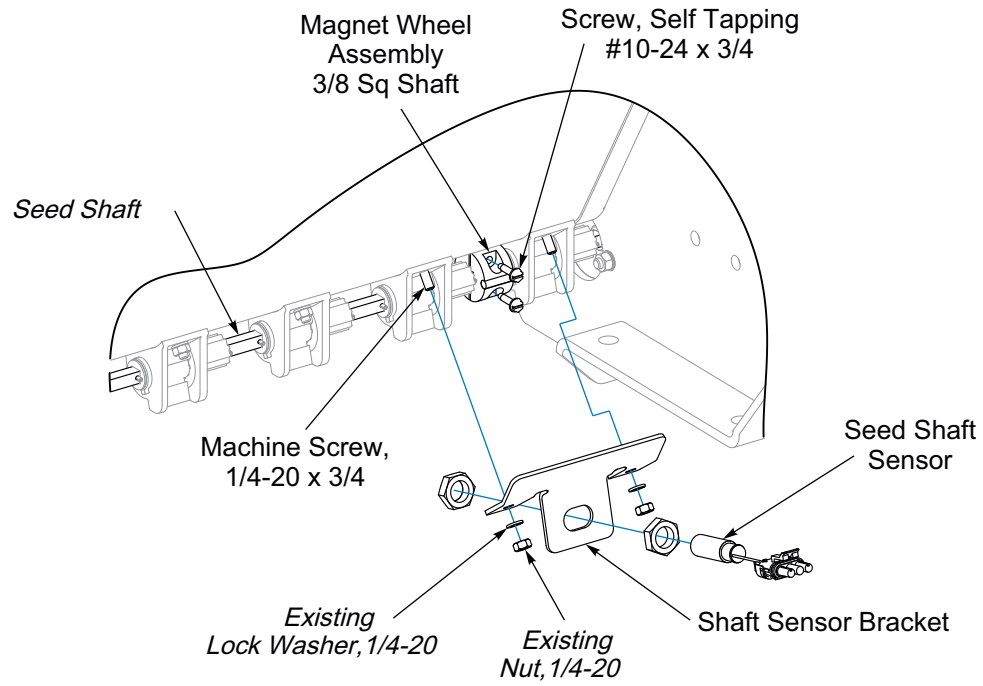
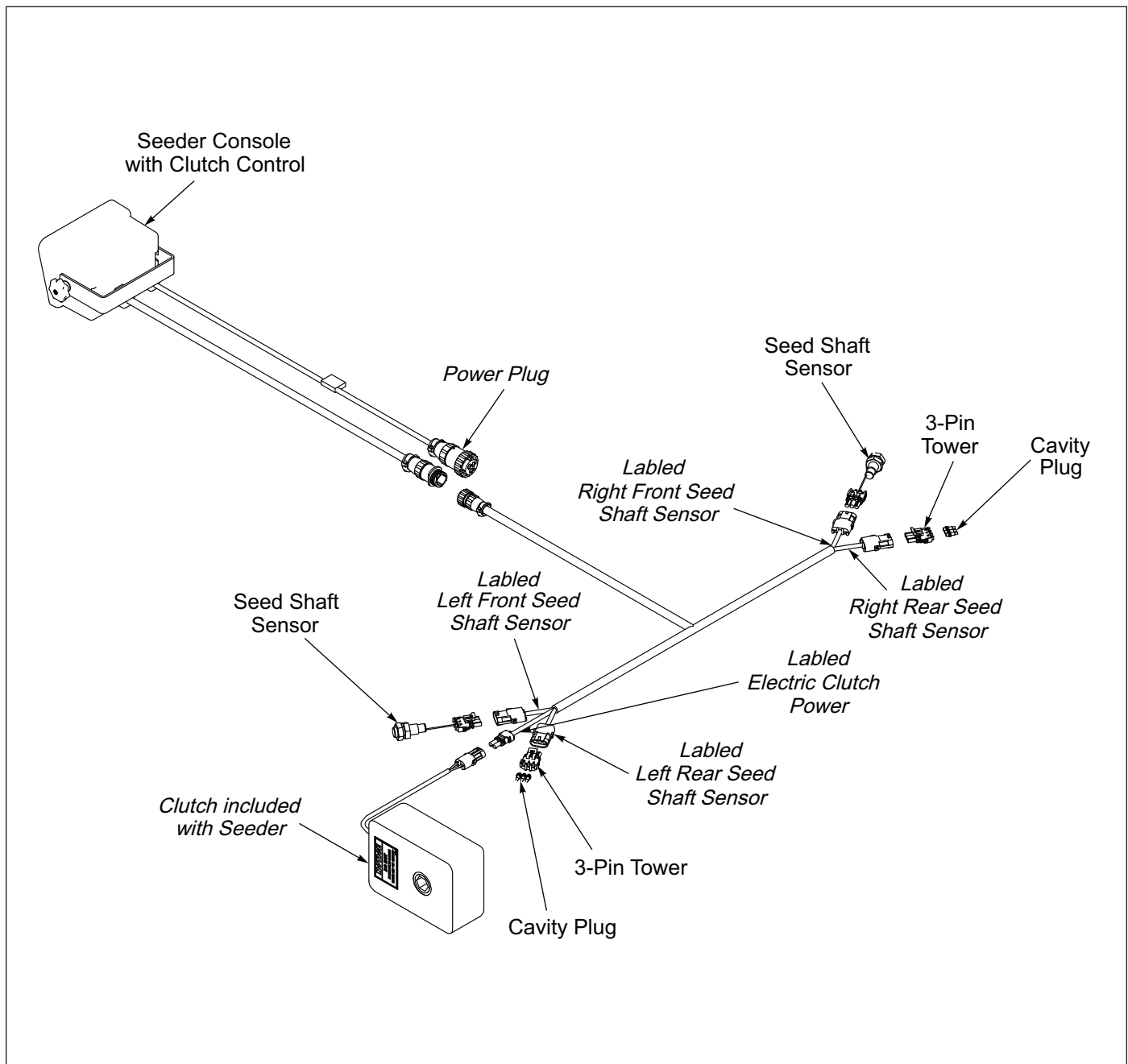


Figure 2-24: Seed Box Brackets

## Seed Shaft Sensor Console and Harness Installation

Mount Console with Clutch Control on Tractor.

1. Route Console Harness with 9-Pin Connector to the Seeder Harness.
2. Attach 3-Pin Power Plug to tractor.
3. Secure console harness with tie wraps.
4. Route Seeder Harness along front frame of seeder. Ensure plug labeled Electric Clutch Power is on the left side.
5. On left side connect plug labeled “Electric Clutch Power” to the Electric Clutch lead. If you do not have an Electric Clutch seal the plug end using a 2-Pin Shroud and Cavity Plug to protect it from the environment. **See Figure 2-25.**
6. Connect plug labeled “Left Front Seed Shaft Sensor” to the left front Seed Shaft Sensor. Seal the plug end using a 3-Pin Tower and Cavity Plugs to protect it from the environment.
7. Repeat for the right side.
8. Secure all Harnesses and Wires with cable tie and tie wraps.



**Figure 2-25: Seed Shaft Sensor Layout**





## Scraper Kit - Optional

**IMPORTANT**

Cannot be used the Coil Tine Track Remover Kit.

**NOTE**

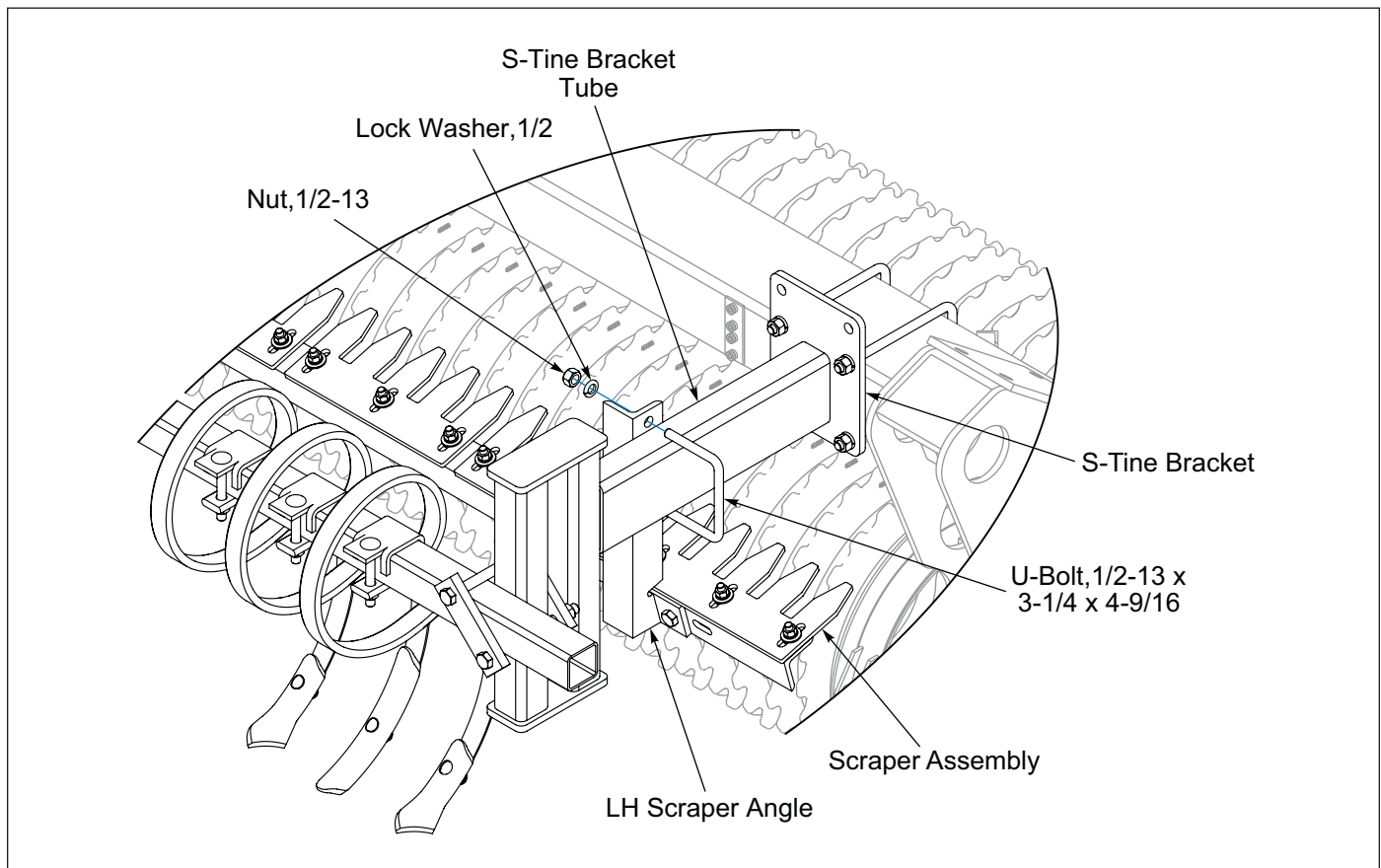
If Seeder has been used, check Front Roller Assembly Wheels that they are tight to one another before installing Scraper Kit. See "Roller Adjustment Procedure" on Page 4-5.

1. Assemble Brackets to the front of Seeder Frame Tube with 1/2-13 U-Bolts, Lock Washers and Nuts except for the 12FT Drawbar Seeder where you mount the Bracket to the Brace Plate with the Brace Hardware. **Do not** tighten at this time. See **Figure 2-26**.

**NOTE**

If you have a S-Tine Tire Track Remover Kit on your 8FT or 10FT Seeder, you do not mount the outer Brackets to the Seeder Frame Tube. Attach the outer RH and LH Angle Brackets to the Track Remover S-Tine Brackets. You may need to reposition the S-Tine Brackets for proper placement of the Scraper Angle. See **Figure 2-26**.

2. Attach the LH and RH Angle Brackets to the Brackets with 1/2-13 x 3-1/4 x 4-9/16 U-Bolts, Lock Washers and Nuts. **Do not** tighten at this time.
3. Attach the Scraper Angle to the LH and RH Angle Brackets with 1/2-13 x 1-1/4 Bolts, Flat Washers, Lock Washers and Nuts. **Do not** tighten at this time.
4. 8FT and 10FT Seeders, attach a center Scraper to the Scraper Angle Center Slot and attach the Scrapers to the Scraper Angle with 3/8-16 x 1-1/4 Carriage Bolts, Flat Washers, Lock Washers, and Nuts.
5. 12FT Seeder, attach two Center Scrapers to the Scraper Angle Center Slots and attach the Scrapers to the Scraper Angle with 3/8-16 x 1-1/4 Carriage Bolts, Flat Washers, Lock Washers, and Nuts.
6. Center entire Scraper Assembly on the Seeder, position Scrapers for proper fit to the Front Roller and tighten hardware. Scrapers should be close enough to the Roller Wheels to be functional but without interference. Some final adjustments maybe required in the field.



**Figure 2-26: 8FT AND 10FT, S-Tine Track Remover and Scraper Kit - Optional**



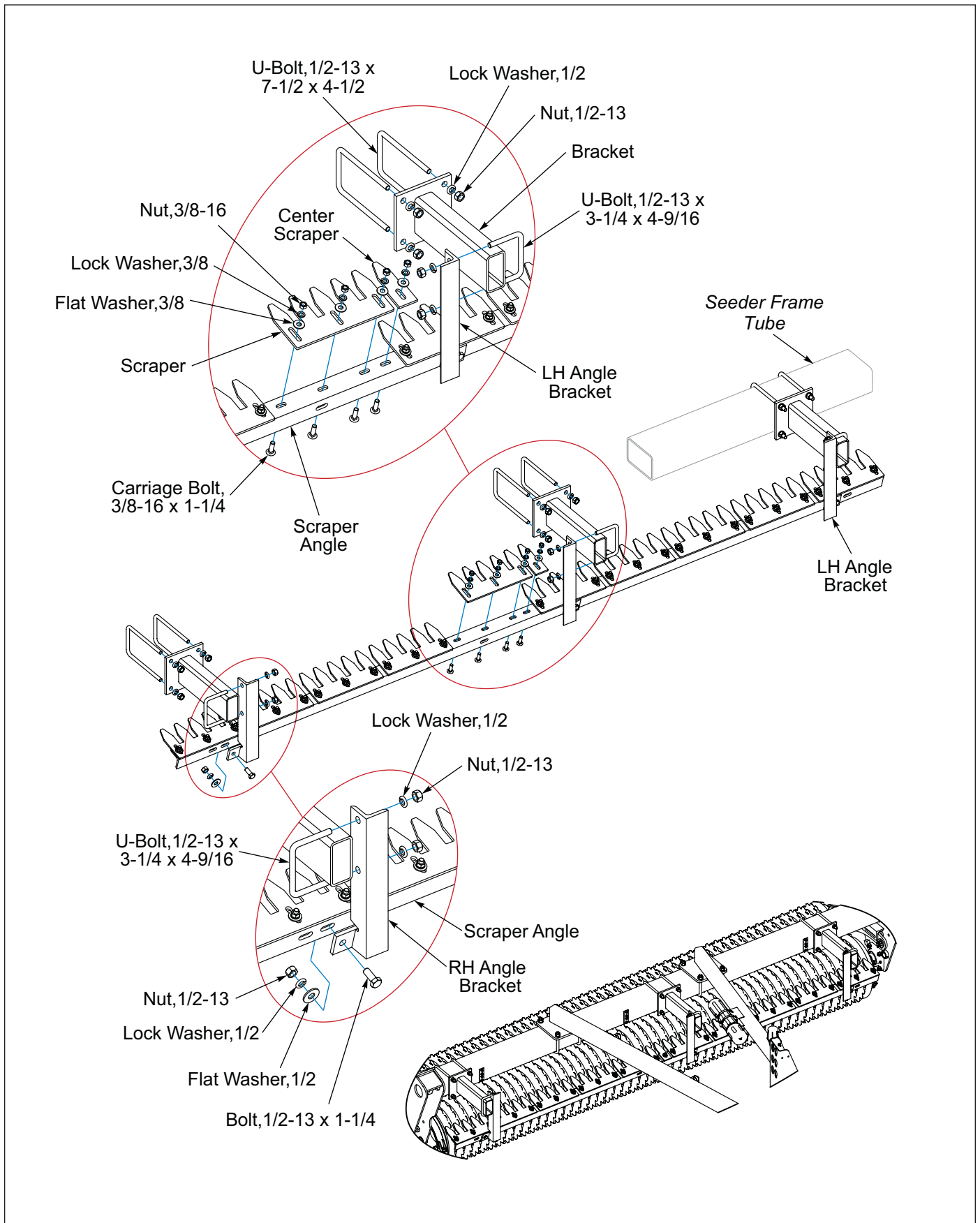


Figure 2-27: Scraper Kit

## S-Tine Tire Track Remover Kit - Optional

### IMPORTANT

S-Tines should not be operated any deeper than necessary to remove Tractor Tire Tracks. Otherwise, wet soil is brought up and will stick to the Front Roller Wheels, the S-Tine draft load is increased, and under some conditions, the S-Tines may deflect back to Front Roller and break.

### NOTE

This S-Tine Tire Track Remover Kit is furnished with 6 S-Tines. Additional S-Tines can be purchased and installed or fewer S-Tines can be used.

1. Assemble the S-Tine Brackets to the front of Seeder Frame Tube with 1/2-13 x 7-1/2 x 4-1/2 U-Bolts, Lock Washers and Nuts. Do Not tighten at this time. Note

that long ends of brackets are downward. Brackets should be about 53" from center of machine. See Figure 2-29.

2. Attach the Tooth Tube to the S-Tine Brackets approximately 5 inches from each end of the Tooth Tube with Straps, 1/2-13 x 6 Bolts, Lock Washers and Nuts. See Figure 2-29.
3. Center Tooth Tube in relationship with the Drawbar or 3-PT Hitch and Tighten U-Bolts.
4. Attach the S-Tines onto the Tooth Tube in the desired position to cover the Tractor Tire Tracks with Clamps, 7/16-14 x 3-1/2 Carriage Bolts and Locknuts.
5. The suggested pattern is to assemble the Reversible Point onto the center S-Tine and a Duck Foot Point on the S-Tine on either side of the center S-Tine with 3/8-16 x 1-3/4 Plow Bolt and Flanged Locknut.

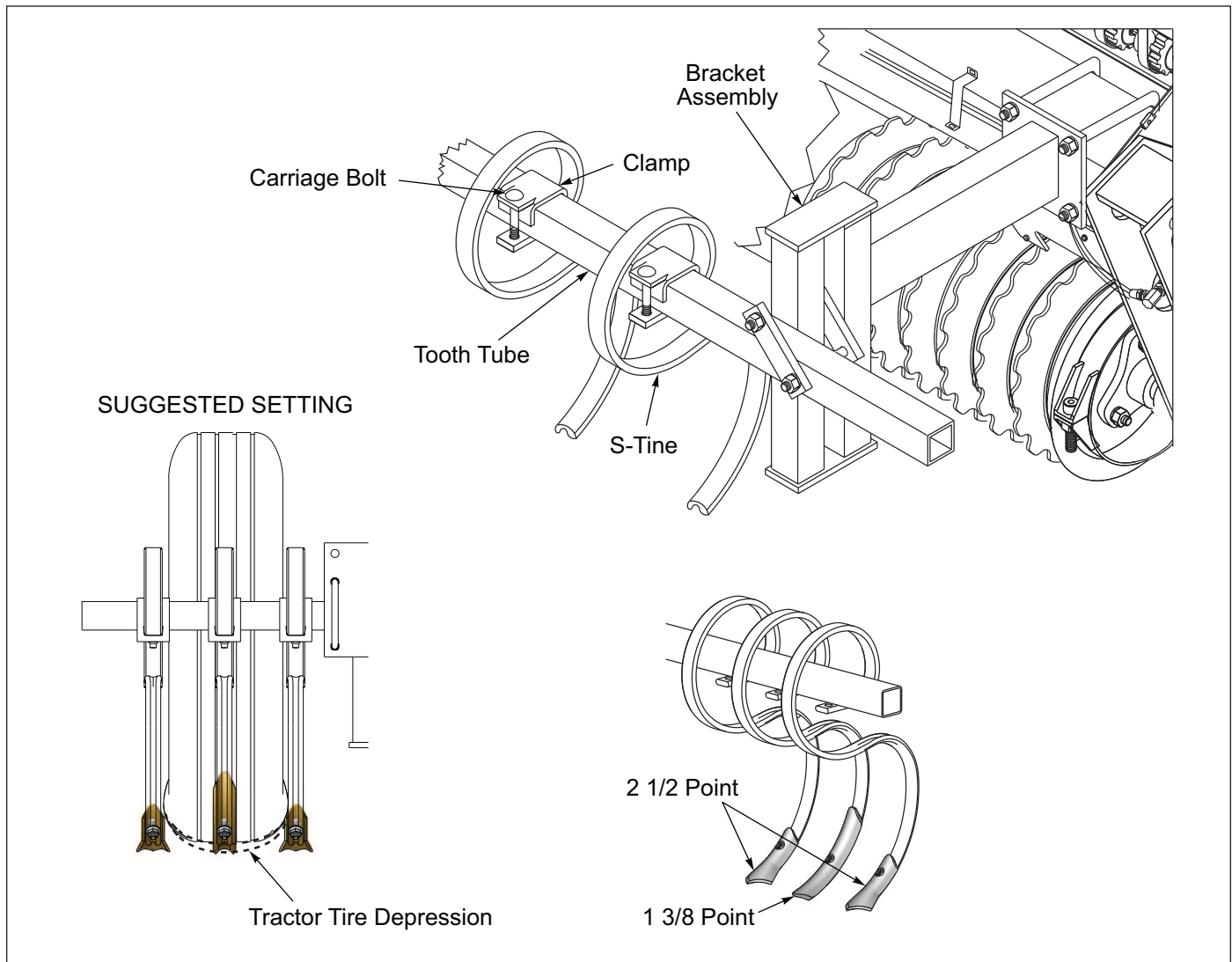


Figure 2-28: S-Tine Setup

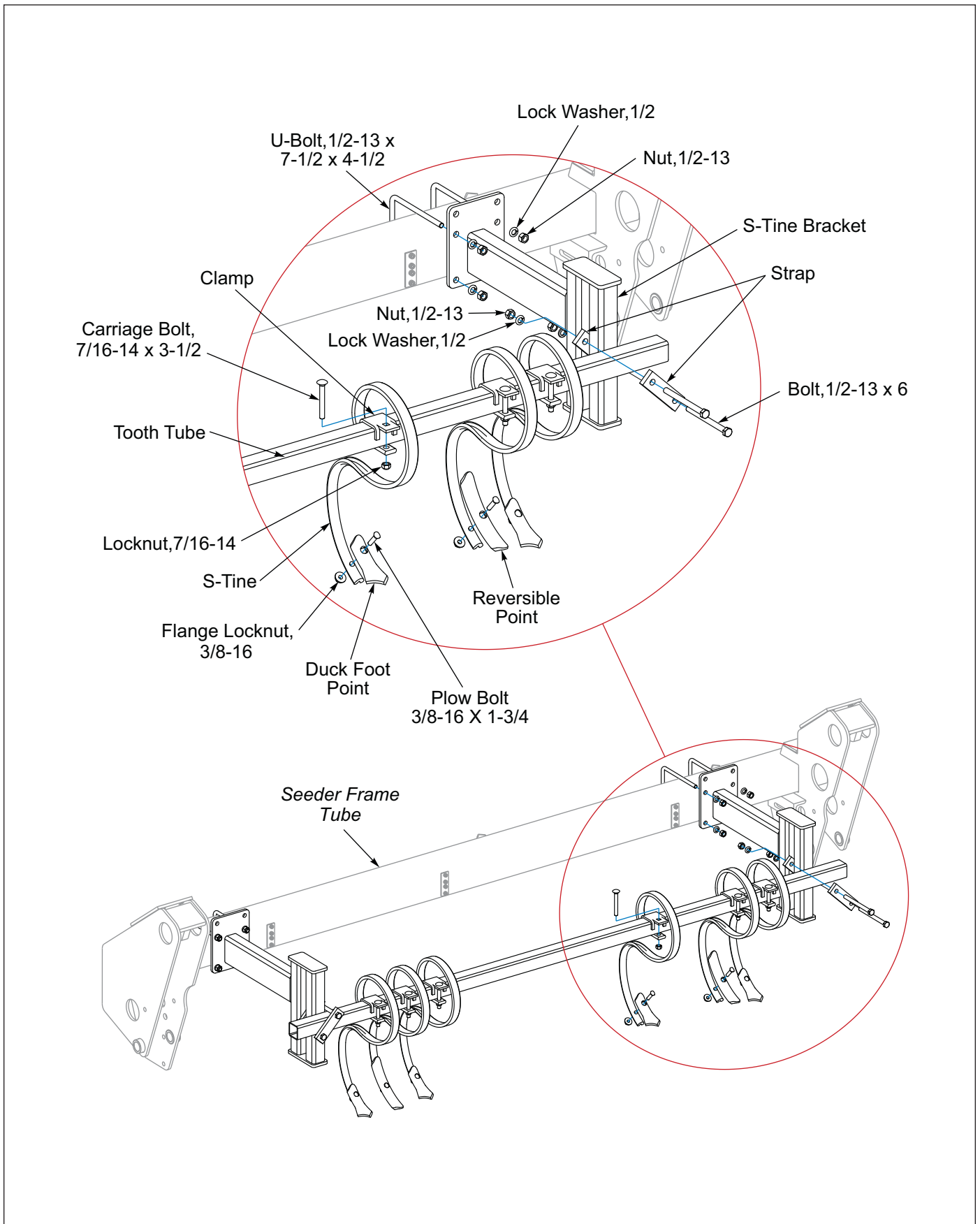


Figure 2-29: S-Tine Track Remover Kit - Optional

## Coil Tine Track Remover - Optional

### **IMPORTANT**

**Cannot be used with the Scraper Kit.**

1. Slide the Coil Tines onto the Round Bar so that the straight leg is frontward. **See Figure 2-30.**
2. Mount an Arm Weldment and a Coil Tine to the Round Bar second hole from the right end and the third hole from the left end with 3/8-16 x 3 Bolts, Flat Washers, Lock Washers and Nuts.
3. Mount the Coil Tines to the Round Bar with 3/8-16 x 2-1/2 Bolts, Flat washers, Lock Washers and Nuts.
4. Position the Brackets on the Seeder Frame Tube and attach with 1/2-13 U-Bolts, Lock Washers and Nuts. **Do not** tighten at this time.
5. Attach the Adjusting Angles to Brackets with Lock Screws. Secure the Adjusting Angles vertically to the Brackets with a 1/2 x 1-1/4 Clevis Pin and Hair Pin Cotter.
6. Attach the Arm Weldment to the Adjusting Angles with 1/2-13 x 1-3/4 Bolts and Locknuts. Tighten the Locknuts to allow free side to side swinging.
7. Center each Coil Tine Track Remover Assemble behind the Tractor Tires. Tighten the Bracket U-Bolts on the Seeder Frame Tube.
8. On each Coil Tine Track Remover Assemble, attach a Chain End Link to an Adjusting Angles with 3/8 x 1-1/4 Bolt, Flat Washer, Lock Washer and Nut. Drape the chain across to the other Adjusting Angle and place the Chain in the Adjusting Angle Slot ensure that the chain

The vertical position can be changed by removing the Clevis Pins and Lock Screws and moving the Adjusting Angles up or down.

To inactivate the Coil Tines, remove the 1/2 x 1-1/4 Clevis Pins and loosen the Lock Screws. Swing the Coil Tine Bar Assembly upward and sideways. Hold Coil Tine Bar Assembly in place by wrapping the Chain under the Round Bar and placing the Chain into the Adjusting Angle Slot. Re-tighten the Lock Screws. Insert Clevis Pin into Adjusting Angle for storage.

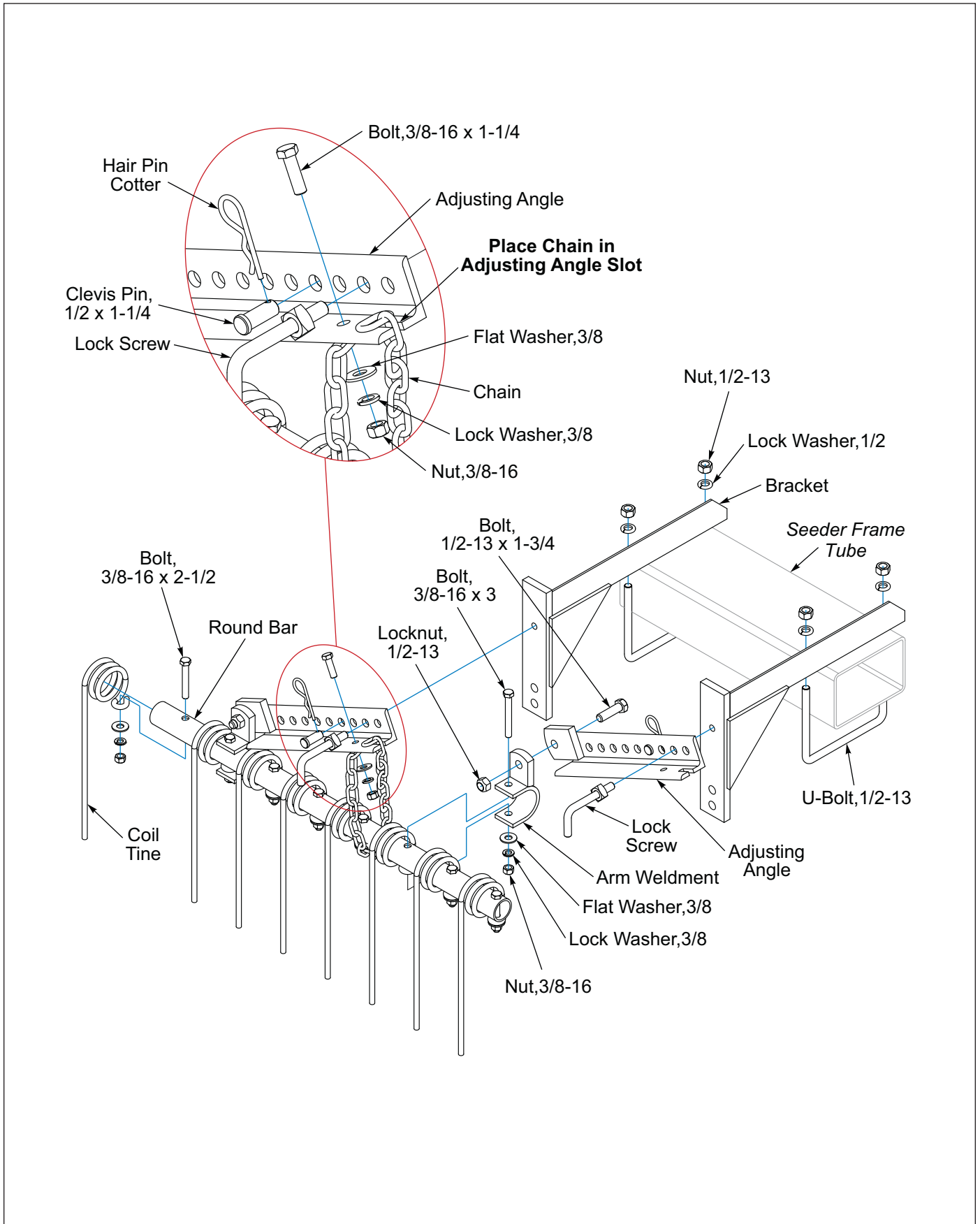


Figure 2-30: Coil Tine Setup



**DANGER**

Never allow anyone to ride on the seeder at any time. Allowing a person to ride on the machine can inflict serious personal injury or death to that person.

**DANGER**

Always lock the tractor drawbar in the center position when transporting the unit. Failure to do so can result in serious injury or death and cause damage to the equipment.

**WARNING**

All hydraulically elevated equipment must have cylinder lockouts installed or be lowered to the ground, when servicing or when equipment is idle. Failure to take preventive measures against accidental lowering can result in serious personal injury.

**DANGER**

When transporting the unit, place cylinder lockouts in the transport lock position after fully extending the cylinders. Insert the lockout pins to secure the cylinder lockouts. Failure to lockout the cylinders can cause the unit to settle during transport, which can result in serious injury or death and cause damage to the equipment.

**CAUTION**

When transporting farm implements on public roads, it is the responsibility of the operator to abide by state and local laws concerning wide loads, speed, safety emblems and safety lighting equipment. Drive at safe speeds, particularly when rounding corners, crossing rough ground or driving on hillsides, to prevent tipping the tractor.

## Tractor Preparation

The Sure Stand Seeder is available as a Pull Type or 3-PT mounted version.

A Pull Type seeder is equipped to be pulled by a tractor with a drawbar, no clevis.

A 3-PT mounted seeder is compatible with CAT 2 Free Link, CAT 2 Quick Coupler and CAT 3 Narrow Quick Coupler.

## Tractor Preparation/Attaching of 3-PT Seeder

1. Brillion 8, 10, and 12 Foot 3-PT Seeders are designed to be pulled with Category 2 Free Link and Category 2 or 3N Quick Coupler 3-PT Hitches. **See Figure 3-1.** Be sure Tractor's Hitch Capacity is not exceeded by the Laden Mass of the Seeder. **Refer to Tractor Operator's Manual.**
2. Be sure Tractor is properly ballasted. A minimum 25% of Tractor and Equipment Laden Mass must be on Tractor Front Wheels in transport position to maintain stability. Calculate the Loaded Seeder Mass. **(See "Specifications" on page 5-1.)** (Seeder weight plus the seed box capacity with desired seed.) **Refer to Tractor Operator's Manual.**
3. Check the Tractor tire inflation levels to ensure that they are properly inflated for the additional Laden Seeder Mass. **Refer to the Tractor Operator's Manual.** Be sure not to over ballast and exceed Tractor Tire Capacity.
4. Set Tractor 3-PT Lower Links to allow lateral (torsional) float. **Refer to Tractor Operator's Manual.** If left rigid, your Brillion Seeder may not follow ground contours resulting in a poor germination.
5. Set Lift Rod length long enough to ensure Seeder can float downward in the case of a furrow or waterway. Lower Links should be the same height, leveling your Brillion Seeder side to side. Fine adjustments may need to be made after hookup is completed. **Refer to the Tractor Operator's Manual.**
6. Attach Seeder to the Tractor's 3-PT Free Link or Quick Coupler using the appropriate size pins and bushings. Be sure to use the hardware provided and is in good working order. **See Figure 3-1.**
7. Refer to the Tractor Operator's Manual for Quick Hitch Operation.

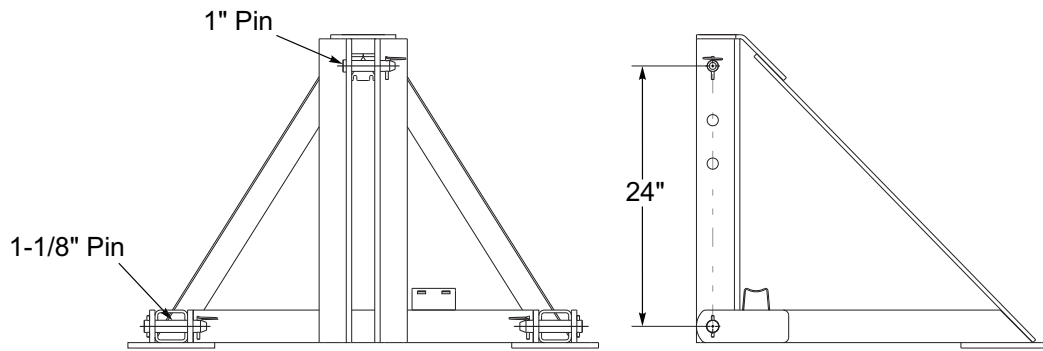


**DANGER**

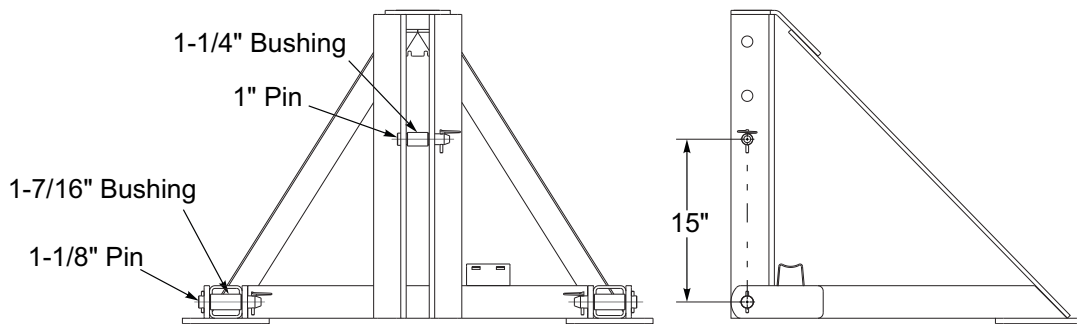
**Do not allow any bystanders to stand between the tractor and the machine while backing up to the machine.**

8. Connect 7-Pin Connector to Tractor Outlet, routing cable by avoiding pinch points.
  - Make sure the tractor has a good clean receptacle, free of dirt and corrosion.
  - Make sure the 7-Pin Connector is inserted ALL the way in. With tighter fitting pins, operator may think the Connector is all the way in, but really isn't.
  - Make sure the tractor receptacle cover latches over the keyway on the 7-Pin Connector to hold the Connector in place.
  - If an operator plugs in the 7-Pin Connector, but the lights do not seem to work right, check the above items to make sure there is a good connection with the 7-Pin Connector.
9. Install Clutch Switch and Harness to tractor if Applicable. **See "Electric Clutch Kit - Optional" on Page 2-15.**
10. Raise seeder. Remove parking pin. **See Figure 3-3.** Adjust or lock tractor sway stabilizers if equipped, centering the Seeder with the Tractor. **Refer to the Tractor Operator's Manual.**
11. Lower Seeder, if necessary level Seeder side to side (laterally) by adjusting Lift Rod length. Level Seeder front to back by adjusting the Tractor Upper Link length as required. **Refer to the Tractor Operator's Manual.**

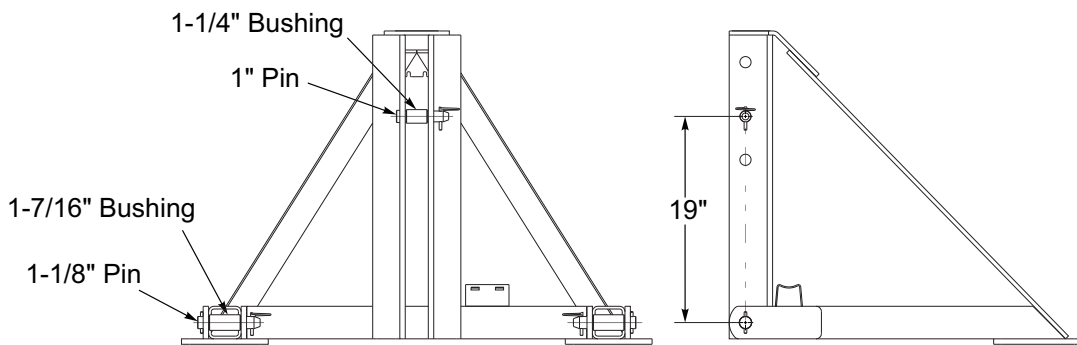




Category 2 Free Link



Category 2 Quick Coupler



Category 3 Narrow Quick Coupler

Figure 3-1: 3-Point Hitch

OPERATION

# Attaching/Detaching 3-PT Hitch Seeder

**! WARNING**

To prevent the machine from tipping backward on the frame, disengage parking pin only when the seeder is fully attached to the tractor. Be sure to observe the following sequences.

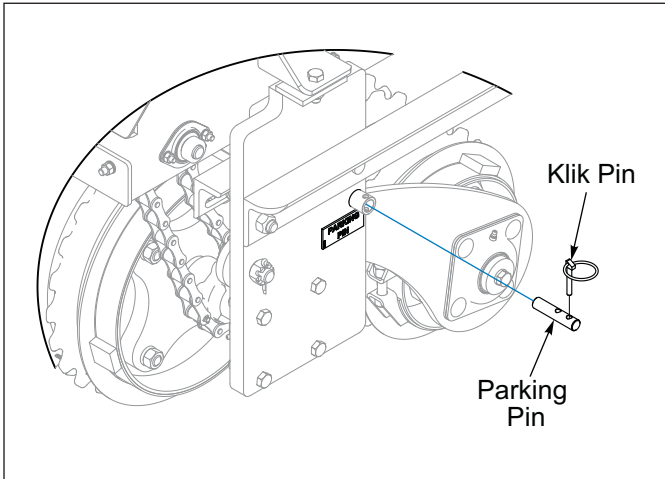


Figure 3-2: Parking Pin

**Hooking Up the Seeder:**

1. Attach Seeder to the Tractor.
2. Raise Seeder. Remove the Klik Pin, pull the Parking Pin into the outer position, replace the Klik Pin. **See Figures 3-2 and 3-3.**

**Unhooking the Seeder:**

1. With Seeder raised, remove the Klik Pin, push in the Parking Pin, replace the Klik Pin. **See Figures 3-2 and 3-4.**
2. Disconnect the Tractor from Seeder, lower Seeder.

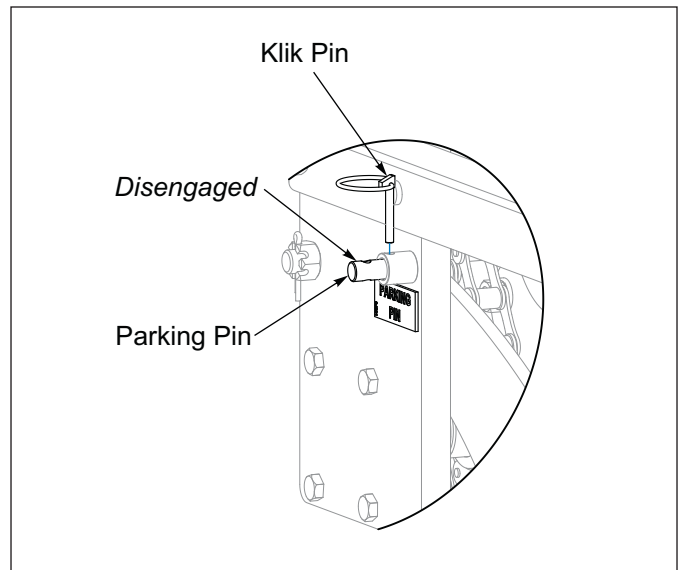


Figure 3-3: Parking Pin Disengaged

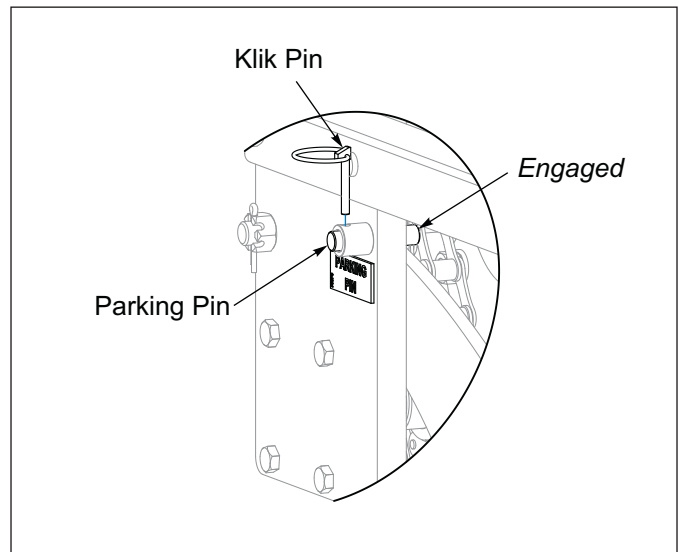


Figure 3-4: Parking Pin Engaged

## Tractor Preparation/Attaching of Pull Type Seeder

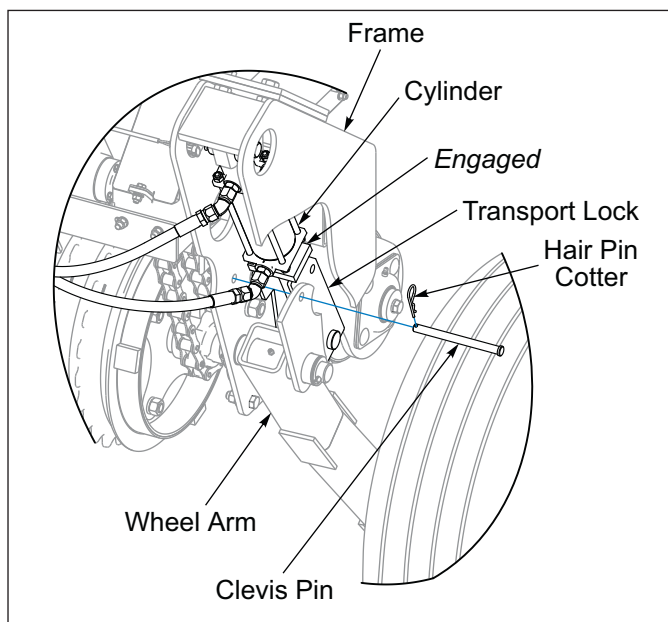
### DANGER

Do not allow any bystanders to stand between the tractor and the machine while backing up to the machine.

1. Align the Tractor Drawbar with the machine. Raise or lower the Drawbar, as needed, using the Jack. Attach the unit with proper size Hitch Pin and Safety Clip.
2. Always move the Jack to the transport position before setting the machine in motion.
3. Clean all Hydraulic Couplings and attach to the Tractor.
4. If Transport Locks are not engaged, fully extend the Hydraulic Lift Cylinders and rotate Transport Locks in the engaged position over the Cylinder Rods. Secure with the Clevis Pins and Hairpin Cotter. See **Figure 3-5**.

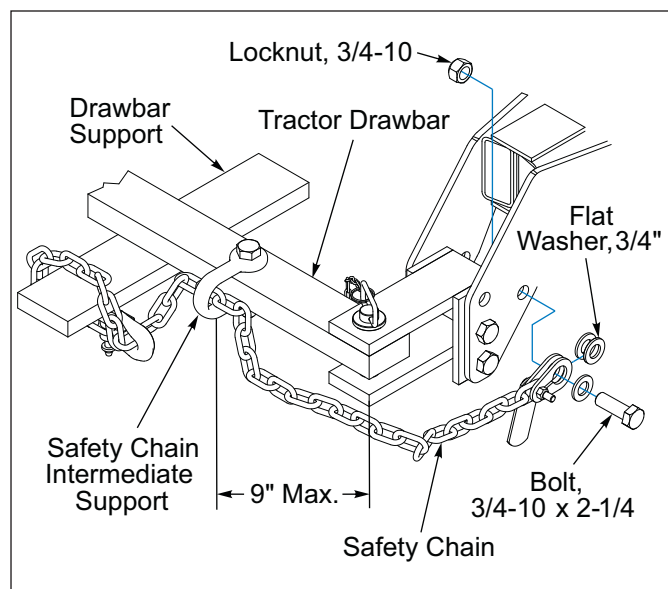
### IMPORTANT

If the Clevis Pin is not installed, the Transport Lock may bounce up and cause significant damage to the Cylinder and Hydraulic Fittings.



**Figure 3-5: Transport Lock Engaged**

5. Attach safety chain to tractor allowing plenty of movement for turning both directions. The safety chain should latch securely to prevent it from coming loose. See **Figure 3-6**.



**Figure 3-6: Safety Chain**

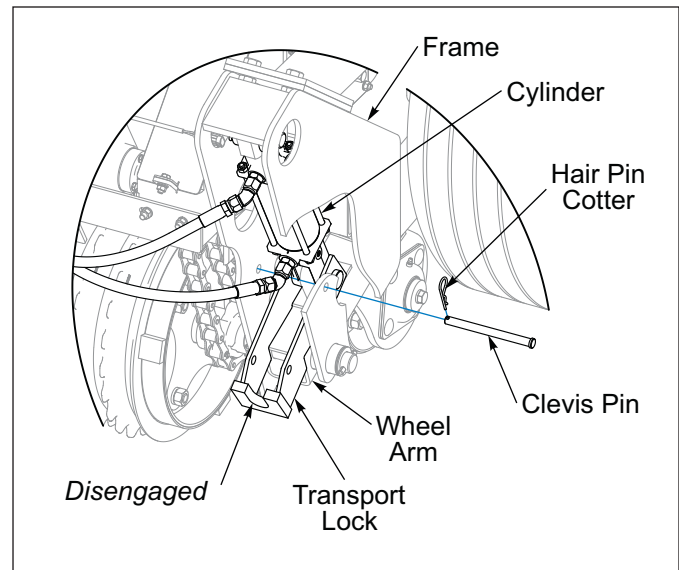
6. Connect the 7-Pin Connector to Tractor Outlet, routing cable by avoiding pinch points.
  - Make sure the Tractor has a good clean Receptacle, free of dirt and corrosion.
  - Make sure the 7-Pin Connector is inserted ALL the way in. With tighter fitting pins, operator may think the Connector is all the way in, but really isn't.
  - Make sure the Tractor Receptacle Cover latches over the keyway on the 7-Pin Connector to hold the Connector in place.
  - If an operator plugs in the 7-Pin Connector, but the lights do not seem to work right, check the above items to make sure there is a good connection with the 7-Pin Connector.
7. Install Clutch Switch and Harness. See **“Transmission Electric Clutch - Optional”** on **Page 3-7**.

## Attaching/Detaching Pull Type Seeder

### Attaching the Seeder for Field Operations:

#### *Seeder parked lowered*

1. Attach Seeder to the Tractor.
2. Raise the Seeder fully to extend the Hydraulic Lift Cylinders and rotate the Transport Locks in the engaged position over the Cylinder Rod. Secure with the Clevis Pins and Hairpin Cotters. **See Figure 3-5.**
3. Raise and rotate Drawbar Jack to stored position before setting the machine in motion.
4. Transport the Seeder to the area to be seeded.
5. Disengage each Transport Lock so that the Transport Lock rests on the Wheel Arm. Insert the Clevis Pin in front of the Transport Lock. **See Figure 3-7.**



**Figure 3-7: Transport Lock Disengaged**

#### *Seeder parked raised*

1. Attach Seeder to the Tractor.
2. Raise and rotate Drawbar Jack to stored position before setting the machine in motion.
3. If not already done, raise Seeder fully to extend the Hydraulic Lift Cylinders and rotate the Transport Locks in the engaged position over the Cylinder Rod. Secure with the Clevis Pins and Hairpin Cotters. **See Figure 3-5.**
4. Transport the Seeder to the area to be seeded.
5. Disengage each Transport Lock so that the Transport Lock rests on the Wheel Arm. Insert the Clevis Pin in front of the Transport Lock. **See Figure 3-7.**

### Detaching the Seeder:

#### *Parking Seeder lowered*

1. Raise the Seeder fully to extend the Hydraulic Lift Cylinders and rotate the Transport Locks to the stored position. Secure with the Clevis Pins and Hairpin Cotters. **See Figure 3-7.**
2. Lower Seeder, relieve pressure from Hydraulic Hoses.
3. Rotate and Lower Drawbar Jack.
4. Disconnect the Tractor from Seeder.

#### *Parking Seeder raised*

1. Raise the Seeder fully to extend the Hydraulic Lift Cylinders and rotate the Transport Locks to the engaged position. Secure with the Clevis Pins and Hairpin Cotters. **See Figure 3-5.**
2. Relieve pressure from Hydraulic Hoses.
3. Rotate and lower Drawbar Jack.
4. Disconnect the Tractor from Seeder.

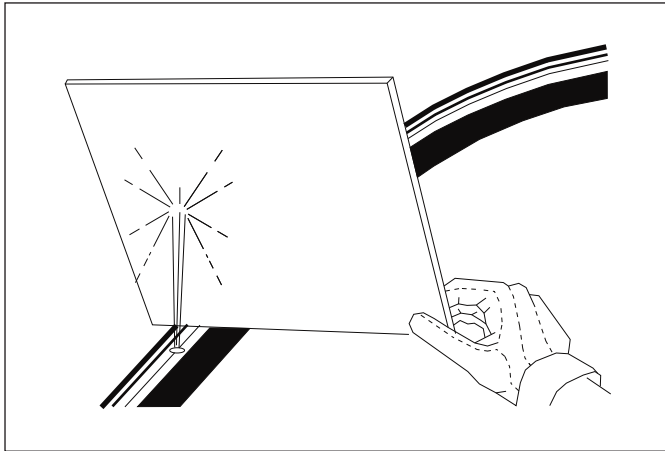
## Hydraulic Lift System

The Seeder is equipped with a Hydraulic Lift System to raise and lower the unit in the field.



### WARNING

Escaping hydraulic fluid can cause serious personnel injury. Relieve system pressure before repairing, adjusting, or disconnecting. Wear proper hand and eye protection when searching for leaks. Use cardboard instead of hands (See Figure 3-8.) Keep all components (cylinders, hoses, fittings, etc.) in good repair.



**Figure 3-8: Hydraulic Leak Detection**

1. If the Hydraulic System is not filled with oil it should be purged of air before transporting and field operations. Carefully hitch the Seeder to the Tractor and connect the Hydraulic Lift Hoses.
2. Disengage the Transport Locks. **See Figure 3-7.**
3. Check to make sure the Tractor Hydraulic Reservoir is full of the manufacturer's recommended oil.
4. Slowly raise the machine until all Lift Cylinders are fully extended. Lower and raise the unit to verify that all Cylinders are working throughout the stroke. Fully extend the Lift Cylinders and continue to hold the lever until all Cylinder Rod movement stops. Raise/Lower machine 5 times to purge air from the system.
5. Do not loosen any Hoses or Fittings. Recheck Tractor Reservoir to make sure it is within operating limits.
6. Re-install Transport Locks. **See Figure 3-5.**

**Lift Circuit approximate oil requirement: .4 gallons.**

## Transmission Electric Clutch - Optional

### IMPORTANT

**At no time use high pressure water or air to clean the Electric Clutch as damage could occur.**

- The Electric Clutch is controlled by a Toggle Switch on the Clutch Switch Box that is mounted to the Tractor.
- The Electric Clutch is disengaged when power (12 Volts) is applied. If there is a power failure or electrical problem, the Seeder will continue to operate, so the machine must be raised to stop seeding.
- Seed Shafts will not rotate when the machine is backed up.
- The Clutch Switch Box contains a 5 Amp Time-Delay Fuse.
- The Electric Clutch must be disengaged (power applied) when Seed Shafts are turned manually for Calibration.
- Check Electric Clutch Operation. The Electric Clutch will disengage when power is applied. (Clutch will make a clicking sound). Set Seeder on the ground and drive a short distance while turning Toggle Switch to "Seed" and "No Seed". The Seed Shaft will stop rotating when Toggle Switch is turned to "No Seed" Position.
- Turn Toggle Switch to "Seed" Position when Seeder is not used to shut off power to prevent possible overheating of Clutch Coil.

## Seed Box Seed Rate Adjustment

**! WARNING**

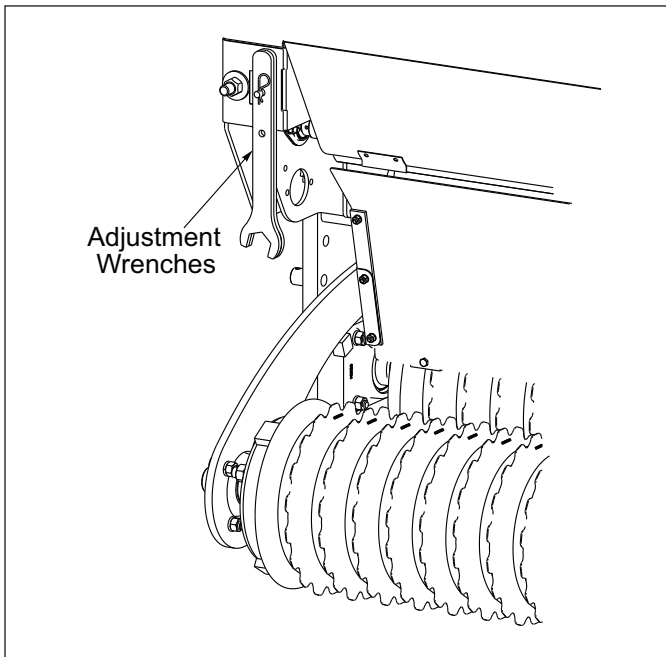
- To prevent damage to seed meters, do not apply excessive force to adjusting nuts. Failure to do so may result in the seed being pinched between the cut-off and washer inside the seed cup.
- Do not close the meters more than 1/8" when there is seed in the meters without rotating the seed shaft to prevent damage to the rotating washers and retainer rings in the seed meters.
- Do not attempt to open the meters more than 1". (Feed rolls could become disengaged from washer in the seed cup.)

**NOTE**

To avoid Seed Meter damage, if there is seed in the Meters, decrease rate in small increments. Decrease rate no more than one nut revolution and rotate Seed Shaft to purge seed from Meters. Continue adjustment as needed.

**NOTE**

Before filling with seed be sure Seed Shaft turns freely and Seed Meters are free of any foreign matter. Wrenches for adjustment are stored on a Pin at the back of the Transmission. See Figure 3-9.



**Figure 3-9: Adjustment Wrenches**

**IMPORTANT**

If equipped, the Clutch must be disengaged when Seed Shafts are turned manually for Calibration.

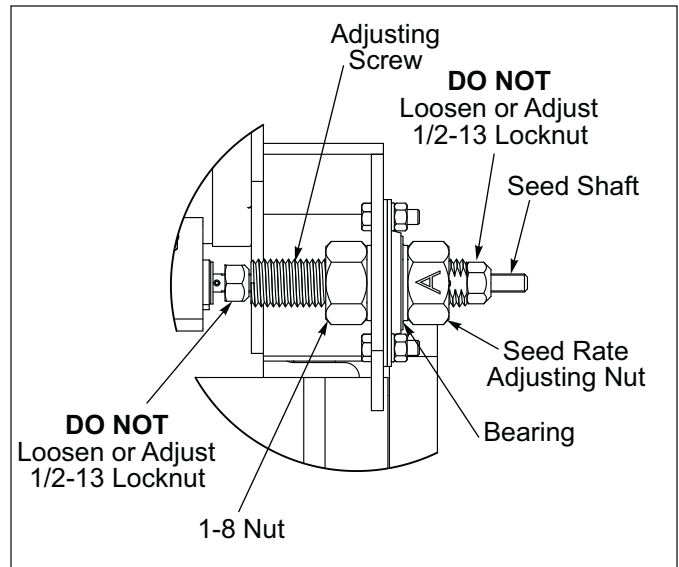
Seed Rate Charts specific to Seeder Model are located inside the Seed Box Cover and in this manual. See Tables 3-1, 3-2 and 3-3. It should be used as a general guide only. Based upon your Seeder Model.

Because of seed variation, a more accurate rate can be determined by turning the 15/16" Hex Nut on the Transmission to calibrate the Seeder. (See "Calibration for Unlisted Seeds" on page 3-10.)

On the right side, the Seed Rate for the Seed Meters can be set by adjusting the Seed Rate Adjusting Nut and Adjusting Screw. See Figure 3-10.

**IMPORTANT**

Do Not Loosen or Adjust the 1/2-13 Locknut. See Figure 3-10.



**Figure 3-10: Seed Box Seed Rate Adjustment**

1. To increase the rate of seeding: loosen the 1-8 Nut on inside of the Bearing and turn the outer Seed Rate Adjusting Nut to the desired higher number setting, then tighten the 1-8 Nut using supplied wrenches.
2. To decrease the rate of seeding: loosen the Seed Rate Adjusting Nut and set it to the new desired position; then tighten the 1-8 Nut using supplied wrenches.

Seed Meters discharge to the front of the machine to aid the operator in determining proper operation. In addition, reflective amber decals are placed on the seed shaft to indicate rotation.

Indicator Settings	POUNDS PER ACRE								POUNDS PER 1000 SQ FT							
	1A	2A	3A	4A	5A	6A	7A	8A	1A	2A	3A	4A	5A	6A	7A	8A
Alfalfa (Uncoated)	5	11	17	26	32	38	46	54	.11	.26	.40	.59	.73	.88	1.06	1.25
Bahia	3	8	14	19	26	32	38	43	.08	.18	.33	.44	.59	.73	.88	.99
Bermuda (Hulled)	3	10	17	27	35	42	48	56	.08	.22	.40	.63	.81	.95	1.1	1.28
Birdsfoot Trefoil (Broadleaf)	5	13	19	27	42	51	61	72	.11	.30	.44	.63	.95	1.17	1.39	1.65
Bluegrass (Kentucky)	2	6	11	16	21	26	30	35	.04	.14	.26	.37	.48	.59	.70	.81
Bluegrass (Park Kentucky)	2	5	10	14	19	22	26	29	.04	.11	.22	.33	.44	.52	.59	.66
Bluegrass (Sherman Big)	2	3	5	8	10	11	13	16	.04	.08	.11	.18	.22	.26	.30	.37
Canola	5	10	16	21	27	33	40	46	.11	.22	.37	.48	.63	.77	.92	1.06
Centipede	5	10	13	17	24	27	32	35	.11	.22	.30	.40	.55	.63	.73	.81
Chickory (Forage)	2	5	8	12	15	18	22	26	.04	.11	.18	.27	.34	.42	.5	.59
Clover (Alsike, Ladino, Sweet, Red)	5	11	19	26	33	42	48	54	.11	.26	.44	.59	.77	.95	1.10	1.25
Clover (Alyce, Calif, Bur, Crimson, Hubam)	3	10	16	24	33	40	48	61	.08	.22	.37	.55	.77	.92	1.1	1.39
Creasted Wheat	2	3	5	6	8	10	11	13	.04	.08	.11	.14	.18	.22	.26	.3
Crown Vetch	5	13	21	30	40	50	59	67	.11	.3	.48	.7	.92	1.14	1.36	1.54
Flax	3	10	16	21	27	32	37	43	.08	.22	.37	.48	.63	.73	.84	.99
Harding Grass	3	8	13	17	22	27	32	37	.08	.18	.3	.4	.52	.63	.73	.84
Highland Bent	3	6	9	12	15	17	20	23	.07	.14	.21	.27	.33	.4	.46	.52
Klein Grass	3	11	19	27	35	45	54	62	.08	.26	.44	.63	.81	1.03	1.25	1.43
Lespedeza (Korean Unhulled)	3	8	14	21	27	33	42	48	.08	.18	.33	.48	.63	.77	.95	1.1
Lespedeza (Korean Hulled)	5	11	19	27	33	42	50	56	.11	.26	.44	.63	.77	.95	1.14	1.28
Lespedeza (Sericea Unhulled)	2	6	11	16	21	26	30	33	.04	.14	.26	.37	.48	.59	.7	.77
Lespedeza (Sericea Hulled)	5	13	21	30	38	48	58	66	.11	.3	.48	.7	.88	1.1	1.32	1.5
Love Grass (Weeping)	3	11	19	27	35	43	53	62	.08	.26	.44	.63	.81	.99	1.21	1.43
Love Grass (Sand)	3	10	16	22	30	38	45	54	.08	.22	.37	.52	.7	.88	1.03	1.25
Millet	3	11	19	27	35	43	53	61	.08	.26	.44	.63	.81	.99	1.21	1.39
Northrup King Mixture	2	4	5	7	8	10	12	14	.04	.08	.12	.16	.19	.23	.27	.31
Red Top	2	5	8	11	13	14	16	19	.04	.11	.18	.26	.3	.33	.37	.44
Reed Canary Grass	2	5	8	11	14	17	21	26	.04	.11	.18	.26	.33	.4	.48	.59
Scott's Family Grass	1	3	4	6	7	8	10	11	.03	.06	.1	.13	.16	.19	.22	.25
Switch Grass (Cleaned and Hulled)	-	5	8	11	14	19	22	27	-	.11	.18	.26	.33	.44	.52	.63
Tillage Radish	5*	12	19	27	34	42	49	57	.11*	.28	.43	.61	.78	.96	1.13	1.31
Timothy	3	8	14	22	29	35	43	51	.08	.18	.33	.52	.66	.81	.99	1.17
Turnip (Purple Top)	3	9	15	22	28	35	41	48	.07	.22	.35	.51	.65	.81	.95	1.09

**Table 3-1: Seed Rate Chart**

\* WILL CRACK SOME SEEDS AT THESE SETTINGS

NOT RECOMMENDED: LENTILS, SORGHUM, SUDAN GRASS

**NOTE**

Brillion assumes no liability pertaining to seeding rates achieved with this seeder. Rates listed are general in nature and should be used as starting points only. Seed varieties and blends listed represent those calibrated through in-house test meters. Variations in actual rates may be realized due to differences in seed lots. For accurate rates with seeds being used, follow the calibration instructions listed on the seed chart inside the box cover or refer to the Operator's Manual. *The information listed in the above seed charts is subject to change without notice.*



**OPERATION**

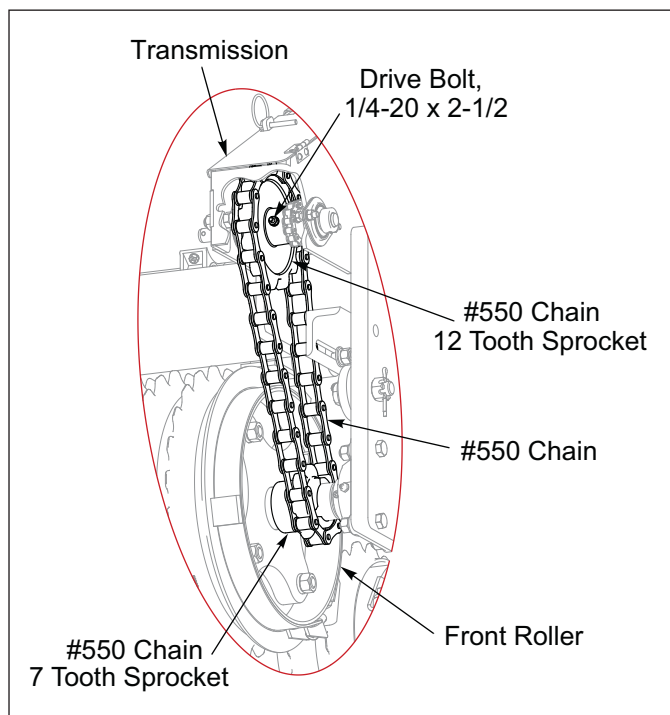
## Transmission Drive Bolt

For Machines without Clutches

**NOTE**

#550 Chain connects Front Roller #550 Chain 7 Tooth Sprocket with Transmission #550 Chain 12 Tooth Sprocket.

Transmission Drive Bolt (1/4-20 x 2-1/2) from the #550 Chain 12 Tooth Sprocket, must be removed for Calibration and can also be removed if it is desired to use the Seeder as a Pulverizer, Rollers only. (The Acre Meter will not register when the Bolt is removed). See **Figure 3-11**.



**Figure 3-11: Transmission Drive Bolt**

**NOTE**

The information listed in the Seed Charts is subject to change without notice.

**IMPORTANT**

Rates are for the 13 Tooth Driver. Double these values for the 26 Tooth Driver. See **Figure 3-13**.

**Front Seed Box may be Calibrated for Unlisted Seed as follows.**

**1. Transmission w/o Clutch**

Remove Transmission Drive Bolt (1/4-20 x 2-1/2) from the #550 Chain 12 Tooth Driven Sprocket. See **Figure 3-11**.

**Transmission w/Clutch - Optional**

Disengage Electrical Clutch. Electrical Power is required to disengage the Clutch.

**2. Raise Seeder and install Transport Locks. See Figure 3-5.**

**3. Place a Canvas or Tarp under the Machine to catch Seed.**

**4. Turn 15/16 Hex on Transmission Shaft Clockwise(CW). See Figure 3-12.**

**8FT Seeder:** Use 50 turns if you follow Step 5. Reference, the Seed Shaft rotates 250 Revolutions per Acre Seeded with 13 Tooth Driver.

**10FT Seeder:** Use 40 turns if you follow Step 5. Reference, the Seed Shaft rotates 200 Revolutions per Acre Seeded with 13 Tooth Driver.

**12FT Seeder:** Use 33 turns if you follow Step 5. Reference, the Seed Shaft rotates 167 Revolutions per Acre Seeded with 13 Tooth Driver.

**5. Weigh Seed (lbs) and Multiply by 5 (10 for 26 Tooth Driver) for approximate Planting Rate in Pounds per Acre.**

## Calibration for Unlisted Seeds

**IMPORTANT**

If equipped, the Clutch must be disengaged when Seed Shafts are turned manually for Calibration. Electrical Power is required to disengage the Clutch.

Brillion/Landoll assumes no liability pertaining to Seeding Rates achieved with this Seeder. Rates listed are general in nature and should be used as starting points only. Seed varieties and blends listed represent those calibrated through in-house test meters.

Variations in actual rates may be realized due to differences in Seed Lots. **For accurate rates with seeds being used, follow the Calibration Instructions listed on the Seed Chart inside the Seed Box Cover.**



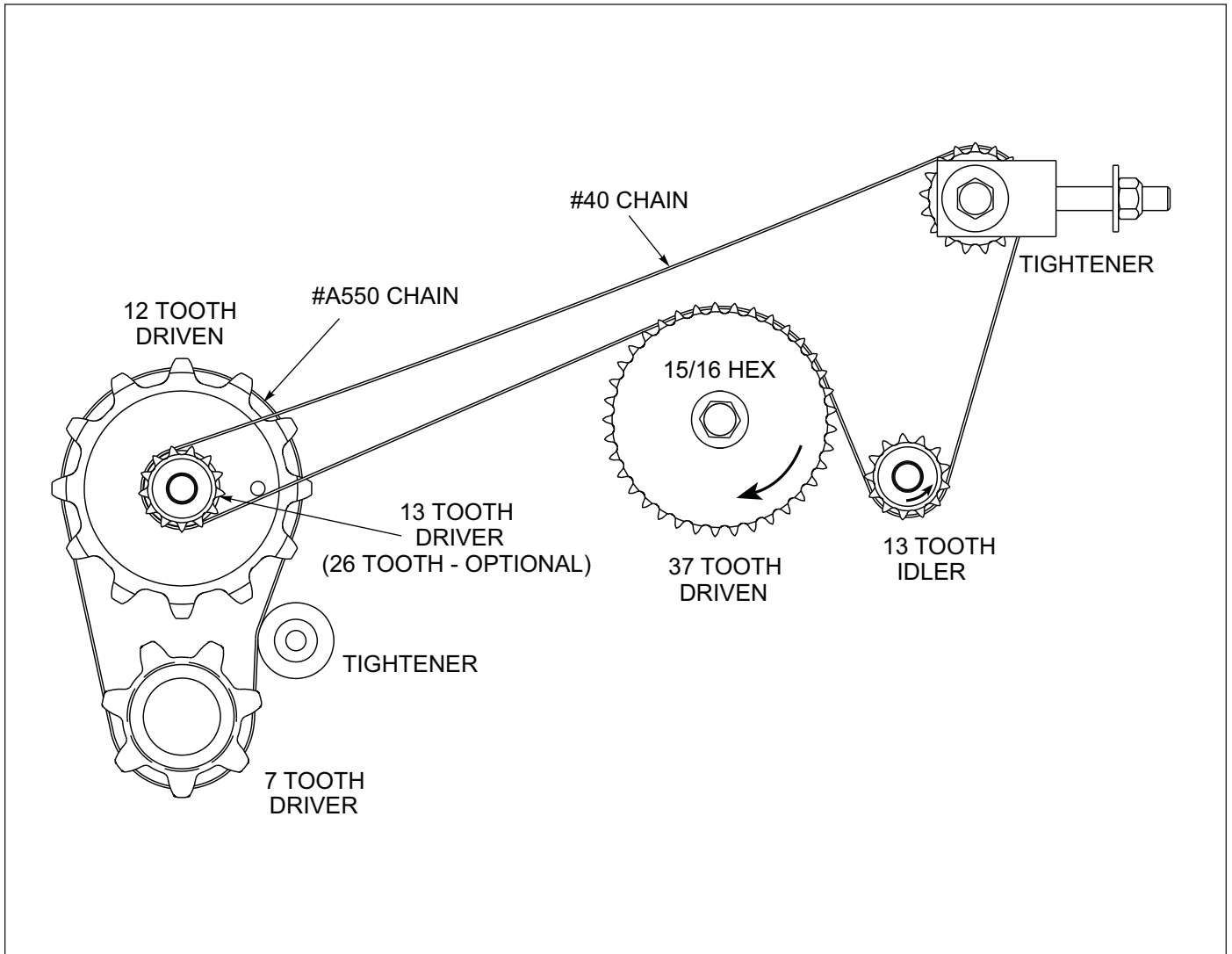


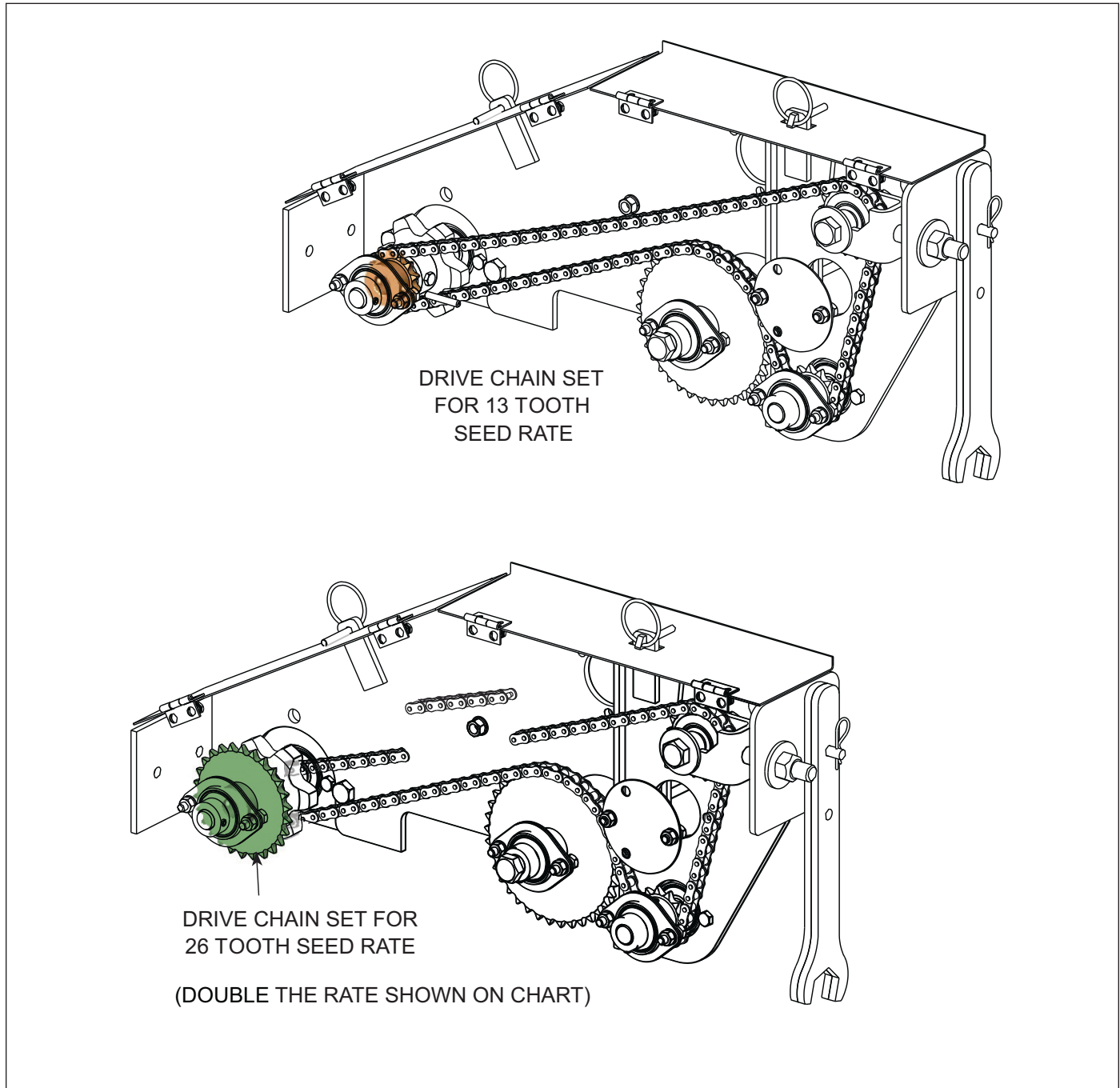
Figure 3-12: Transmission Drive

**OPERATION**

**Speed-Up Kit - Optional**

Seed rates can be doubled by using a 26 Tooth Sprocket and following the procedure below: follows: **See Figure 3-13.**

1. Loosen and remove #550 and #40 Drive Chains.
2. Remove 1/4-20 x 2 1/2 Bolt, Lock Washer and Nut from #550 chain 12 Tooth Sprocket Hub on Front Transmission Shaft.
3. Remove the 1/4 x 1-1/2 Roll Pin from 13 Tooth Sprocket Hub on the Front Transmission Shaft.
4. Remove the Locking Collar from the left side of the Front Transmission Shaft.
5. Move the shaft far enough to the right to remove the 13 Tooth Sprocket.
6. Install the new 26 Tooth Sprocket.
7. Replace all items (except #40 chain) in reverse order.
8. Add extra links to #40 chain.
9. Adjust chain tension. **See Figure 4-5.**



**Figure 3-13: Speed-Up Kit Setup**

## Loup Acre Meter Kit - Optional (After 05/15/2012)

Acre Meter is dust and splash resistant, under no circumstances should this unit be submerged in any conductive, corrosive, or flammable liquid. At no time use high pressure water or air to clean it, as this can damage the unit. (See “Acre Meter Troubleshooting” on Page 4-9.)

### Battery Replacement

The battery operated acre counter uses 3 AA batteries. The batteries should last between 5 and 10 years. The acre counter will last much longer than that. Eventually, you will have to replace the batteries. The “BATT” LED will light when the batteries require replacement. Remove the acre counter from the machine and undo the 4 screws on the back of the case. This will separate the housing from the rear plate. Replace the batteries with 3 high quality AA alkaline batteries.

### Settings for Loup Acre Meters

The battery operated Acre Meter operates in one of two modes.

1. In sleep mode, the display is blank, and the counter is accumulating acres. Sleep mode will be entered if a button is not pressed for 20 seconds.
2. In entry mode, the display is on, and the operator can enter values. To get into entry mode, press the **\*/FUNC** button. If you continue to press the **\*/FUNC** button, the acre counter will cycle through the functions that it can perform. The LEDs above the display indicate which function is selected.

#### The available functions are:

Field Acres, Total Acres, Pulses per 400 feet, Width, Password and Low Battery

### Field Acres

Press the **\*/FUNC** button until the “FIELD” LED is lit. The digits indicate the acres covered since the field acre counter was cleared.

To clear the field acre count, press the **UP** and **DOWN** buttons simultaneously for two seconds. If a password has been entered, you will not be able to clear the total acre count. Field acres will count in tenths of an acre up to 9999.9 acres.

### Total Acres

Press the **\*/FUNC** button until the “FIELD” and “TOTAL” LEDs are lit. The digits indicate the acres covered since the total acre counter was cleared.

To clear the total acre count, press and hold the **UP** and **DOWN** buttons for two seconds. If a password has been entered, you will not be able to clear the total acre count. Total acres will count from .1 to 99999 acres.

### Pulses Per 400 Feet

Press the **\*/FUNC** button until the “PULSES” LED is lit. The number in the display indicates how many pulses are generated for every 400 feet driven. There are two methods to enter the pulses per 400 feet:

1. If you know the number, select it using the **UP** and **DOWN** buttons. When you press the **\*/FUNC** button, the Acre Counter will accept the number in the display as the new pulses per 400 feet. See **Table 3-2**.
2. If you do not know the pulses per 400 feet, press and hold the **UP** and **DOWN** buttons until the “0” appears in the display. The “PULSES” LED will blink. The acre counter is now counting shaft rotations. Enter the cab and drive 400 feet. Press the **\*/FUNC** button to wake up the acre counter. The “PULSES” LED will light. The number displayed is the pulses per 400 feet. Press the **\*/FUNC** button to accept the setting.

If a password is set, you will not be able to adjust the pulses.

### Width

Press the **\*/FUNC** button until the “WIDTH” LED is lit. The number displayed is the length of your machine in feet.

To adjust the width, press the **UP** and **DOWN** buttons. If a password has been entered, you will not be able to adjust the width.

The width can be adjusted from .1 to 99.9 feet, in tenths of a foot.

### Password

The password function allows you to protect the total acre count, pulses per 400 feet, and width settings with a password. This stops anyone from accidentally changing those settings. When the acre counter is shipped, the password is disabled. You can modify the pulses per 400 feet and machine width at any time.

Press the **\*/FUNC** button until the “PASS” LED is lit. The digits will display the word “Ent” or “dis”.

**If the display shows “dis”**. The password is disabled. The total acre count, pulses/400 feet, width, and password settings can be adjusted using the **UP** and **DOWN** buttons. The password can also be changed using the **UP** and **DOWN** buttons.

## OPERATION

---

**If the display shows “Ent”:** You must enter your password using the **UP** and **DOWN** buttons. When your password is displayed, press the **\*/FUNC** button to test the password. If the password is correct, you will be able to change the acre counter settings. The password will be viewable until the acre counter powers down. When the acre counter is powered up again, you will have to re-enter the password to change settings.

If the password is not correct, you will not be able to change the acre counter settings. When the **“PASS”** function is selected again, **“Ent”** will appear in the display.

### Changing the Password

Select a new password using the **UP** and **DOWN** buttons. Press the **\*/FUNC** button until the word **“Set”** appears in the display. Release the **\*/FUNC** button. The number in the display is your new pass code. Make sure you record this number. Press and hold the **\*/FUNC** button until the word **“dis”** appears in the display.

If the password is forgotten, it can be disabled by removing the batteries. The password is intended for rental units. It is recommended that a seal be affixed to the rear plate of the acre counter to determine if the settings have been tampered with.

## Loup Acre Meter Kit - Optional (Before 05/15/2012)

### Settings

- When the meter is set to “count” mode in pulses screen, meter will register only magnetic wheel revolutions.
- The meter must be in sleep mode (blank screen) to calculate acres or to count pulses.
- The count screen must have a value other than zero (0000) to scroll to other modes or screens.
- To reset the FIELD ACRES screen to zero (0000), press the up and down buttons simultaneously.

### To Program Meter

1. Press the function button to scroll to pulses screen.
2. Enter the number of pulses using the up or down buttons for the model listed in the chart. **See Table 3-3.**
3. Press the function button to set the pulses. (If screen goes blank before you press the function button, repeat steps 1 and 2).
4. Press the function button to scroll to the width screen.
5. Enter the width of seeder using the up or down buttons for the model listed in the chart. **See Table 3-3.**

6. Press the function button to set the width. (If screen goes blank before you press the function button, repeat steps 4 and 5).
7. Press the function to scroll through the screens to check that the correct pulses and width have been entered.

### To Enter Password

1. Press the function button to scroll to password screen.
2. Pick a numeric password and enter it by using the up or down buttons, until your password is displayed.
3. Press the function button to set password; screen will show “(set)”. Record number - it is required if you decide to disable password.
4. Let screen go blank - password is now entered.
5. Press the function button to scroll to the password screen it will show **“Ent”**. If the screen does not show **“Ent”**, repeat steps 2, 3 and 4.

### To Disable Password

1. Press the function button to scroll to the password screen it will show **“Ent”**.
2. Use up or down button to enter password (number).
3. Press the function button to scroll around to pass screen again. Number entered in step 2 will appear.
4. Press up or down button to enter 0.
5. Press the function button; (dis) will appear. Password is now disabled.

MODEL				PULSES per 400 FT	WIDTH (Feet)
SSP T604				22	5.0
SSP4	SS4			44	4.0
SSP5	SS5			44	5.0
SSP6	SS6			44	6.0
SSP8	SS8			58	8.0
SSP10	SS10			58	10.0
SSP12	SS12			58	12.0
SSP108	SS108			58	8.0
SSP110	SS110			58	10.0
SSP112	SS112			58	12.0
SSP208	SSP2081	SS208	SS2081	58	8.0
SSP210	SSP2101	SS210	SS2101	58	10.0
SSP212	SSP2121	SS212	SS2121	58	12.0
SSP308		SS308		29	8.0
SSP310		SS310		29	10.0
SSP312		SS312		29	12.0
SLP8		SL8		314	8.0
SLP10		SL10		314	10.0
SLP12		SL12		314	12.0
SLP204		SLP2041		128	4.0
SLP206		SLP2061		128	6.0
SLP304		SLP3041		64	4.0
SLP306		SLP3061		64	6.0
LSP5				128	5.0
LSP6				128	6.0
LSS6				128	6.0
SLP208	SLP2081	SL208	SL2081	116	8.0
SLP210	SLP2101	SL210	SL2101	116	10.0
SLP212	SLP2121	SL212	SL2121	116	12.0
SLP308	SLP3081	SL308	SL3081	58	8.0
SLP310	SLP3101	SL310	SL3101	58	10.0
SLP312	SLP3121	SL312	SL3121	58	12.0
BOS4F1	BOS4S1	BOS6F1	BOS6S1	45	4.0
BOSB4F1	BOSB4S12	BOSB6F1	BOSB6S1	45	6.0
BPS6	BPSB6			51	6.0
GLP643		SSLP643		69	5.3
4620-24				45	24.0
4630-36				per Seeder	36.0
X19-27	XL28-36	XXL38-46		90	per Model
WFP23-37	WFP38-52			90	per Model

**Table 3-2: Acre Meter Settings (After 05/15/2012)**

## TABLE OF CONTENTS

### OPERATION

MODEL				PULSES	WIDTH
SSP T604				293	5
SSP4		SS4		578	4
SSP5				578	5
SSP6		SS6		578	6
SSP8		SS8		764	8
SSP10		SS10		764	10
SSP12		SS12		764	12
SSP108		SS108		760	8
SSP110		SS110		760	10
SSP112		SS112		760	12
SSP208	SSP2081	SS208	SS2081	764	8
SSP210	SSP2101	SS210	SS2101	764	10
SSP212	SSP2121	SS212	SS2121	764	12
SSP308		SS308		382	8
SSP310		SS310		382	10
SSP312		SS312		382	12
SLP8		SL8		4147	8
SLP10		SL10		4147	10
SLP12		SL12		4147	12
SLP204	SLP2041			1690	4
SLP206	SLP2061			1690	6
SLP304	SLP3041			845	4
SLP306	SLP3061			845	6
LSP5				1690	5
LSP6				1690	6
LSS6				1690	6
SLP208	SLP2081	SL208	SL2081	1528	8
SLP210	SLP2101	SL210	SL2101	1528	10
SLP212	SLP2121	SL212	SL2121	1528	12
SLP308	SLP3081	SL308	SL3081	764	8
SLP310	SLP3101	SL310	SL3101	764	10
SLP312	SLP3121	SL312	SL3121	764	12
BOS4F1	BOS4S1	BOS6F1	BOS6S1	600	4
BOSB4F1	BOSB4S1	BOSB6F1	BOSB6S1	600	6
BPS6	BPSB6			679	6
GLP643		SSLP643		917	5

**Table 3-3: Acre Meter Settings (Before 05/15/2012)**

## Seed Shaft Sensor Console with Clutch Control - Optional

### Basic Operation:

During normal operation the Console LED for the Seed Shaft will not be illuminated. The Shaft Sensor will be activated by the Magnet Wheel Assembly installed on the Seed Shaft being monitored. The Shaft Sensor is a standard Loup Shaft Sensor, set to 20 second delay timing. When no signal is detected for 20 seconds by the sensor, the LED in the Console will illuminate and the audible alarm will sound indicating a fault. The alarm will become silent after 30 seconds and will not sound again until the Seed Shaft returns to a fully functional condition.

### **NOTE**

*If Shaft Sensor stall alarm occurs, be aware that the seeder has not been planting for 20 seconds.*

The Clutch Master toggle switch allows you to go from "SEED" to "NO SEED" operations.

## General Operation

1. The minimum horsepower requirements are typically 6-8 horsepower per foot. This will vary widely due to speed, moisture, and types of soils. Local dealers can help in making recommendations for your areas. For 3-PT Hitch Models size tractor by 3-PT Hitch Capacity.
2. Operating speed is typically 3-6 mph. Excessive speed can result in undesirable germination, seeder bouncing, or other unpredictable results. Reduce speed in rocky conditions to prevent wheel breakage.

## Transporting the Seeder

1. Check and follow all federal, state, and local requirements before transporting the Seeder.
2. The Seeder should be transported only by tractor required for field operation. The machine weight should not exceed more than 1.5 times the tractor weight. Maximum transport speed for the Seeder is 20 mph for the machine.



### **CAUTION**

**Excessive speed may result in loss of control of the tractor and machine, reduced braking ability, or failure of the machine tire or structure. Do not exceed the machines maximum specified ground speed regardless of the capability of the maximum tractor speed.**

3. When towing equipment in combination, the maximum equipment ground speed shall be limited to the lowest specified ground speed of any of the towed machines.

Maximum transport speed shall be the lesser of travel speed specified in the operator's manual, speed identification symbol, information sign of towed equipment, or limit of road conditions.

- **EXAMPLE:** If the tractor is capable of 25 mph, the first implement has a SIS for 19 mph, and the last implement's operator's manual states its specified ground speed is 15 mph, the towed equipment combination ground speed limitation is 15 mph.

4. Slow down when driving on rough roads. Reduce speed when turning, or on curves and slopes to avoid tipping. Equipment altered other than the place of manufacture may reduce the maximum transport speed. Additional weight, added tanks, harrowing attachments, etc. may reduce machine load carrying capabilities.
5. A safety chain is provided with the implement to insure safe transport.
  - The safety chain should have a tensile strength equal to or greater than the gross weight of the implement. The chain is attached to the lower hitch clevis hole with two flat washers between the clamp plates to assure a tight connection. Always use a 1" diameter Grade 8 bolt for this connection.
  - Attach the safety chain to the tractor drawbar. Provide only enough slack in the chain for turning. Do not use an intermediate chain support as the attaching point for the chain on the tractor. Do not pull the implement by the safety chain
  - Regularly inspect the safety chain for worn, stretched, or broken links and ends. Replace the safety chain if it is damaged or deformed in any way.
6. Check that tires are of proper size, load rating, and inflated to manufacture specifications before transporting. Check wheel lug bolts to ensure tightness.
7. Know the transport heights and widths of the unit before transporting. Use caution when transporting near bridges and power lines.



### **WARNING**

**Electrocution can occur without direct contact.**

8. Use provided pins that properly fits the Lift Arms or Quick Hitch and Machine Hitch.
  - Check to see that the tractor hitch capacity is rated to carry the Laden Mass of the Seeder.



**OPERATION**

---

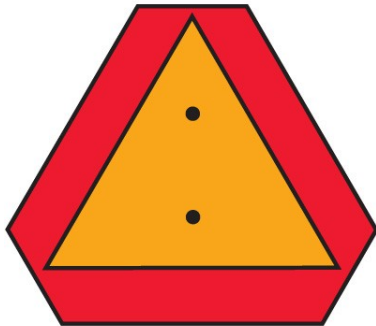
9. Plug in the safety lights to the tractor 7-Pin Connector.
10. Fully raise the Seeder Hydraulic Lift and 3-PT Hitch.
11. Install transport lock. Do not depend solely on implement hydraulics for transport. (See “Transport Lock Engaged” on page 3-5.)



**WARNING**

**Failure to use transport lock during transport may result in permanent equipment damage, serious injury, or death.**

12. Transport during daylight hours whenever possible. Always use flashing warning lights, except where such use is prohibited by law. Make sure lights, reflectors and SMV emblem are clearly visible and operating. Remove any obstructions such as dirt, mud, stalks or residue that restricts view before transporting. **See Figure 3-14.**



**Figure 3-14: SMV Sign**



**General Torque Specifications**

(rev. 4/97)

This chart provides tightening torques for general purpose applications when special torques are not specified on process or drawing. Assembly torques apply to plated nuts and capscrews assembled without supplemental lubrication (as received condition). They do not apply if special graphite moly-disulfide or other extreme pressure lubricants are used. When fasteners are dry (solvent cleaned) add 33% to as received condition torque. Bolt head identification marks indicate grade and may vary from manufacturer to manufacturer. Thick nuts must be used on Grade 8 capscrews. Use value in [ ] if using prevailing torque nuts.

**TORQUE SPECIFIED IN FOOT POUNDS**

UNC SIZE	SAE Grade 2	SAE Grade 5	SAE Grade 8	UNC SIZE	SAE Grade 2	SAE Grade 5	SAE Grade 8
1/4-20	4 [5]	6 [7]	9 [11]	1/4-28	5 [6]	7 [9]	10 [12]
5/16-18	8 [10]	13 [13]	18 [22]	5/16-24	9 [11]	14 [17]	20 [25]
3/8-16	15 [19]	23 [29]	35 [42]	3/8-24	17 [21]	25 [31]	35 [44]
7/16-14	24 [30]	35 [43]	55 [62]	7/16-20	27 [34]	40 [50]	60 [75]
1/2-13	35 [43]	55 [62]	80 [100]	1/2-20	40 [50]	65 [81]	90 [112]
9/16-12	55 [62]	80 [100]	110 [137]	9/16-18	60 [75]	90 [112]	130 [162]
5/8-11	75 [94]	110 [137]	170 [212]	5/8-18	85 [106]	130 [162]	180 [225]
3/4-10	130 [162]	200 [250]	280 [350]	3/4-16	150 [188]	220 [275]	320 [400]
7/8-9	125 [156]	320 [400]	460 [575]	7/8-14	140 [175]	360 [450]	500 [625]
1-8	190 [237]	408 [506]	680 [850]	1-14	210 [263]	540 [675]	760 [950]
1-1/8-7	270 [337]	600 [750]	960 [1200]	1-1/8-12	300 [375]	660 [825]	1080 [1350]
1-1/4-7	380 [475]	840 [1050]	1426 [1782]	1-1/4-12	420 [525]	920 [1150]	1500 [1875]
1-3/8-6	490 [612]	1010 [1375]	1780 [2225]	1-3/8-12	560 [700]	1260 [1575]	2010 [2512]
1-1/2-6	650 [812]	1460 [1825]	2360 [2950]	1-1/2-12	730 [912]	1640 [2050]	2660 [3325]

**METRIC:**

Coarse thread metric class 10.9 fasteners and class 10.0 nuts and through hardened flat washers, phosphate coated, Rockwell "C" 38-45. Use value in [ ] if using prevailing torque nuts.

Nominal thread diameter (mm)	Newton Meters (Standard Torque)	Foot Pounds (Standard Torque)	Nominal Thread Diameter (mm)	Newton Meters (Standard Torque)	Foot Pounds (Standard Torque)
6	10 [14]	7 [10]	20	385 [450]	290 [335]
7	16 [22]	12 [16]	24	670 [775]	500 [625]
8	23 [32]	17 [24]	27	980 [1105]	730 [825]
10	46 [60]	34 [47]	30	1330 [1470]	990 [1090]
12	80 [125]	60 [75]	33	1790 [1950]	1340 [1450]
14	125 [155]	90 [115]	36	2325 [2515]	1730 [1870]
16	200 [240]	150 [180]	39	3010 [3210]	2240 [2380]
18	275 [330]	205 [245]			

## Hydraulic Fitting Torque Specifications

### 37 degree JIC, ORS, &ORB (REV. 10/97)

This chart provides tightening torques for general purpose applications when special torques are not specified on process or drawing. Assembly torques apply to plated nuts and capscrews assembled without supplemental lubrication (as received condition). They do not apply if special graphite moly-disulfide or other extreme pressure lubricants are used. When fasteners are dry (solvent cleaned) add 33% to as received condition torque. Bolt head identification marks indicate grade and may vary from manufacturer to manufacturer. Thick nuts must be used on Grade 8 capscrews. Use value in [ ] if using prevailing torque nuts

### TORQUE SPECIFIED IN FOOT POUNDS

#### PARKER® BRAND FITTINGS

Dash Size	37 Deg. JIC	O-ring (ORS)	O-ring boss
-4	11-13	15-17	13-15
-5	14-16	-----	21-23
-6	20-22	34-36	25-29
-8	43-47	58-62	40-44
-10	55-65	100-110	58-62
-12	80-90	134-146	75-85
-16	115-125	202-218	109-121
-20	160-180	248-272	213-237
-24	185-215	303-327	238-262
-32	250-290	-----	310-340

#### GATES® BRAND FITTINGS

Dash Size	37 Deg. JIC	O-ring (ORS)	O-ring boss
-4	10-11	10-12	14-16
-5	13-15	-----	-----
-6	17-19	18-20	24-26
-8	34-38	32-40	37-44
-10	50-56	46-56	50-60
-12	70-78	65-80	75-83
-14	-----	65-80	-----
-16	94-104	92-105	111-125
-20	124-138	125-140	133-152
-24	156-173	150-180	156-184
-32	219-243	-----	-----

#### AEROQUIP® BRAND FITTINGS

Dash Size	37 Deg. JIC	O-ring (ORS)	O-ring boss
-4	11-12	10-12	14-16
-5	15-16	-----	16-20
-6	18-20	18-20	24-26
-8	38-42	32-35	50-60
-10	57-62	46-50	75-80
-12	79-87	65-70	125-135
-14	-----	-----	160-180
-16	108-113	92-100	200-220
-20	127-133	125-140	210-280
-24	158-167	150-165	270-360

### Fasteners

Before operating your Brillion machine, check all hardware for tightness. Use the Tightening Torque Table as a guide.

After a few hours of use, check entire machine and tighten any loose nuts or bolts. Daily or periodic checks should be made thereafter.

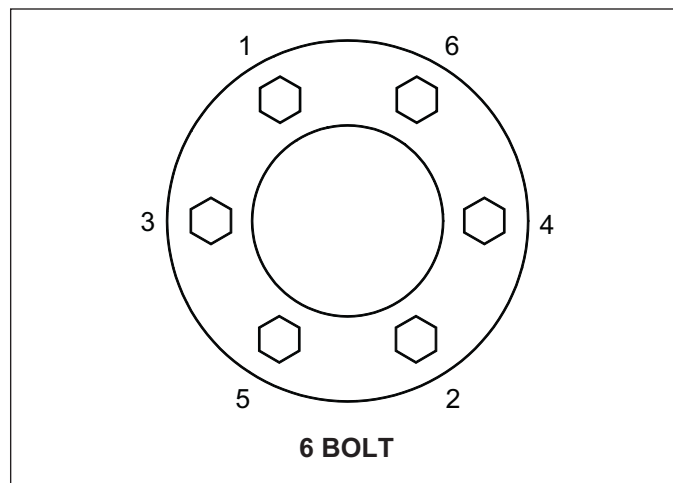
When replacing bolts, be sure to use fasteners of equal grade.

## Tires

**Recommended Tire Size:** 9.5L-15 - 6 Ply Rating

**Tire Inflation Pressure:** 44 PSI

When Re-Installing 1/2-20 x 1 Wheel Bolts tighten to 50 Ft-Lbs. using the sequence in **Figure 4-1**. Then tighten to full torque of 80-85 Ft-Lbs.



**Figure 4-1: Tightening Sequence**

## Wheel Hub Bearing Maintenance

Wheel Bearing maintenance should be performed at the beginning of every season of use. Check the Wheel Bearings periodically for excessive end play. If needed, adjust or replace them using the following procedure:

1. Place the Frame on blocks or stands sufficient to lift the Tire clear of the ground.
2. Remove the Tire.
3. Remove the Hub Cap, Cotter Pin and Slotted Nut.
4. Remove the Hub. Clean and inspect the Bearings and Hub Cavity. Replace any worn or defective parts.
5. Repack the Bearings using a high-quality Wheel Bearing Grease.
6. Slide the Single Lip Seal onto the Spindle. Do not install the Seal into the Hub.

### NOTE

*The Single Lip Seals should point away from the Hub to keep contaminants out and allow the grease to pass.*

7. Slide the Inner Bearing Cone and Hub onto the Spindle.
8. Install the Outer Bearing Cone and Slotted Nut.
9. Tighten the Slotted Nut while rotating the Hub until there is a slight resistance to wheel rotation. Then, back the Slotted Nut off one notch, until the wheel rotates freely without end play.

10. Slide the Single Lip Seal to the Hub and install the Seal in the Hub.
11. Install a new Cotter Pin and re-install the Hub Cap.
12. Grease Wheels Hubs every 50 hrs. **See Figure 4-2.**

## Lubrication Maintenance

- All machines have a grease zerk on the bearing on each end of the front and rear rollers. Pull type machines have a zerk on each wheel arm pivot as well. **See Figure 4-2.**
- Oil roller chains periodically.
- Repack wheel bearings annually.
- Grease all bearings every 20 hours.
- Grease wheel arms every 4 hours when machine in constantly raised.
- When the machine is not used for some time, exposed portions of the hydraulic cylinder rods must be cleaned and covered with a thick coat of grease to prevent corrosion, which will damage the seals.

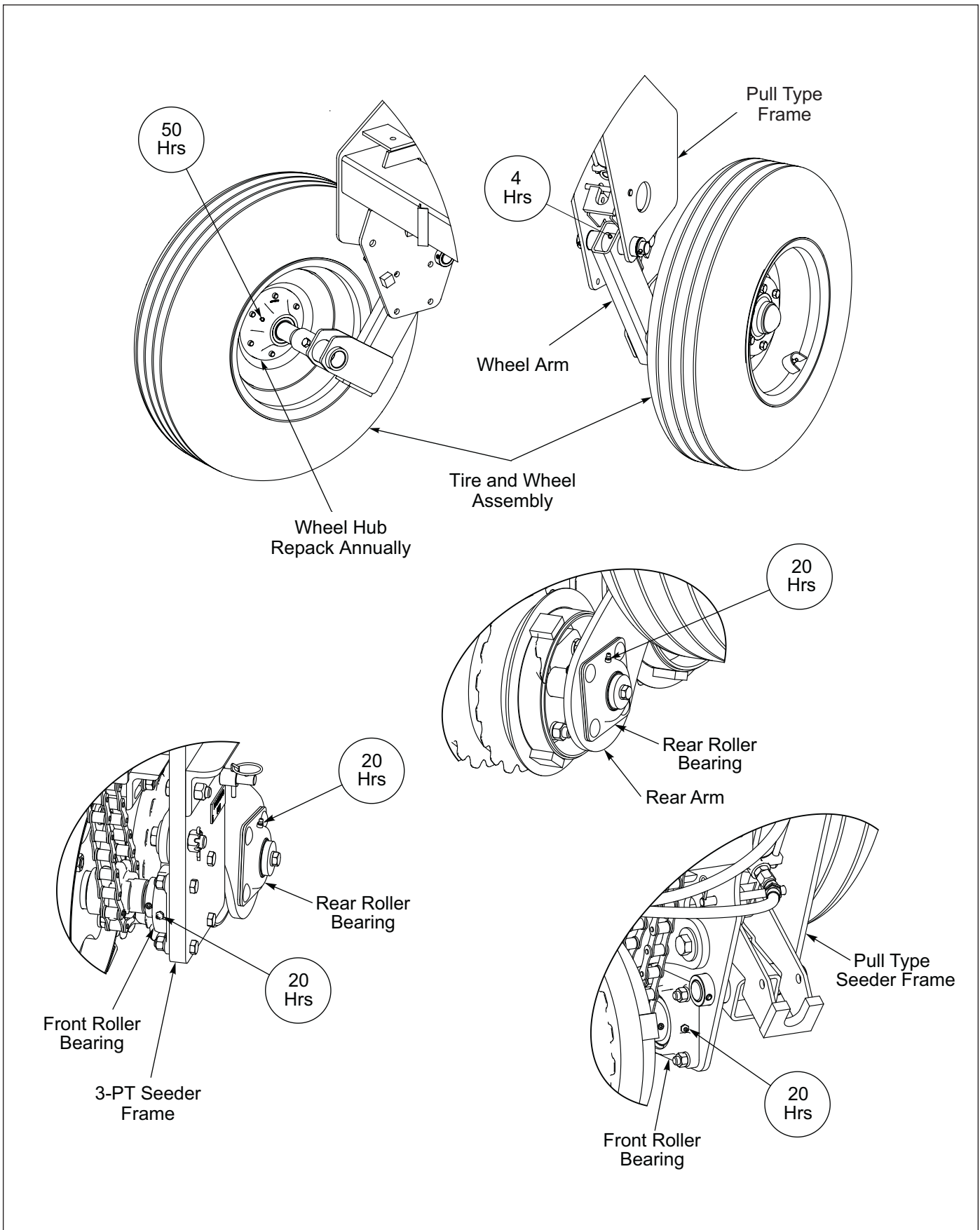


Figure 4-2: Lubrication Intervals

## Hydraulic Maintenance

### IMPORTANT

Lower the unit to the ground, and relieve hydraulic pressure before attempting to service any hydraulic component.



### WARNING

Escaping fluid under pressure can be nearly invisible and have enough force to penetrate the skin causing serious injury. Use a piece of cardboard, rather than hands to search for suspected leaks. Wear protective gloves and safety glasses or goggles when working with Hydraulic System.

1. Check the tractor hydraulic fluid level per tractor owner's manual and after any leakage. Check fluid level with the cylinders in the retracted position.
2. If a cylinder or valve leaks, disassemble the parts to determine the cause of the leak. Any time a cylinder is opened up, or whenever any seal replacement is necessary, it is advisable to clean all parts and replace all seals. Seal kits are available from your Landoll/Brillion dealer.
3. Check all hydraulic hoses weekly. Look for binding or cracking. Replace all worn or defective parts immediately.
4. Transport Locks are provided to hold the implement in a raised position. Do not attempt to perform any service work under the implement without first installing the Transport Locks. Before servicing any hydraulic component, lower the implement to the ground and relieve all system pressure. If a hydraulic component is disconnected, repaired, or replaced, it will be necessary to purge the system of air before operation. **See "Hydraulic Lift System" on Page 3-7.**

## Front and Rear Rollers

After an initial run of 5-10 hours, check the Front and Rear Roller Assemblies to ensure that the Wheels are tight to one another and that the Clamp Bands are tight. If not slide the Roller Wheels tight together and adjust the Roller Clamp Bands. Tighten the Clamp Band Socket Head Bolt (Clamp Band open section) over Roller Drum weld seam to 75 Ft-Lbs. Thereafter check Front and Rear Roller Assemblies every 50-100 hours.

### IMPORTANT

To maximize seed germination, peaks on Rear Roller Wheels should line up with valleys on the Front Roller Wheels. This will require adjusting the Clamp Bands on each end of the Rear Roller Drum and moving the Wheels until valleys and peaks line up.

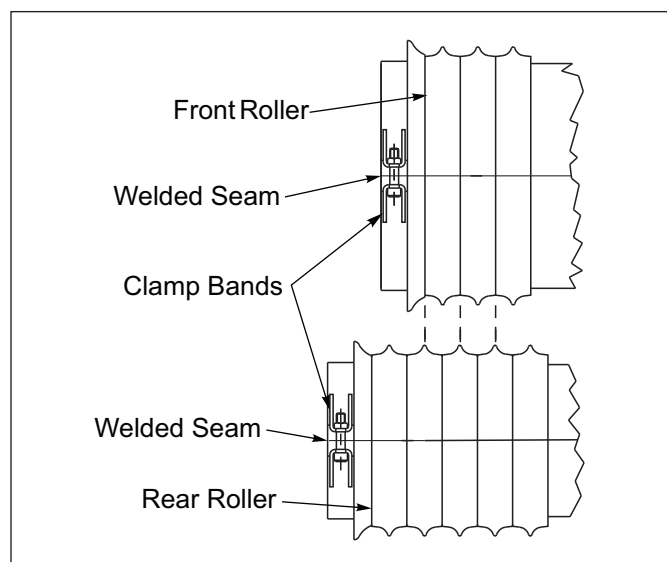
### NOTE

Failure to position the Clamp Band Socket Head Bolt (Clamp Band open section) over the Roller Drum weld seam will cause Clamp Band to loosen and slide.

## Roller Adjustment Procedure

1. Adjust the Front Roller Wheels first. Loosen Clamp Bands and slide the Roller Wheels snug against each other, centering the entire assembly under the Deflector.
2. Position the Clamp Band Socket Head Bolt (Clamp Band open section) over the weld seam on the Roller Drum.
3. Slide the Clamp Band against the End Wheel on each end of the Roller and tighten the Clamp Band Bolt to 75 Ft-Lbs. **See Figure 4-3.**

Adjust the Rear Roller Wheels in the same manner as you adjusted the Front Roller Wheels except, start at the center of the Rear Roller and align the peaks of the Rear Roller Wheels with the valleys of the Front Roller Wheels. This will provide the best alignment of worn Roller Wheels.

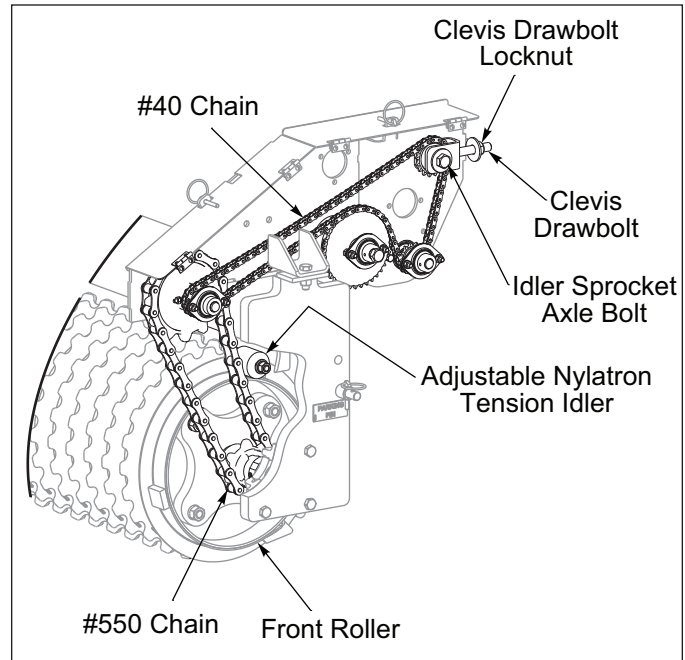


**Figure 4-3: Clamp Bands**

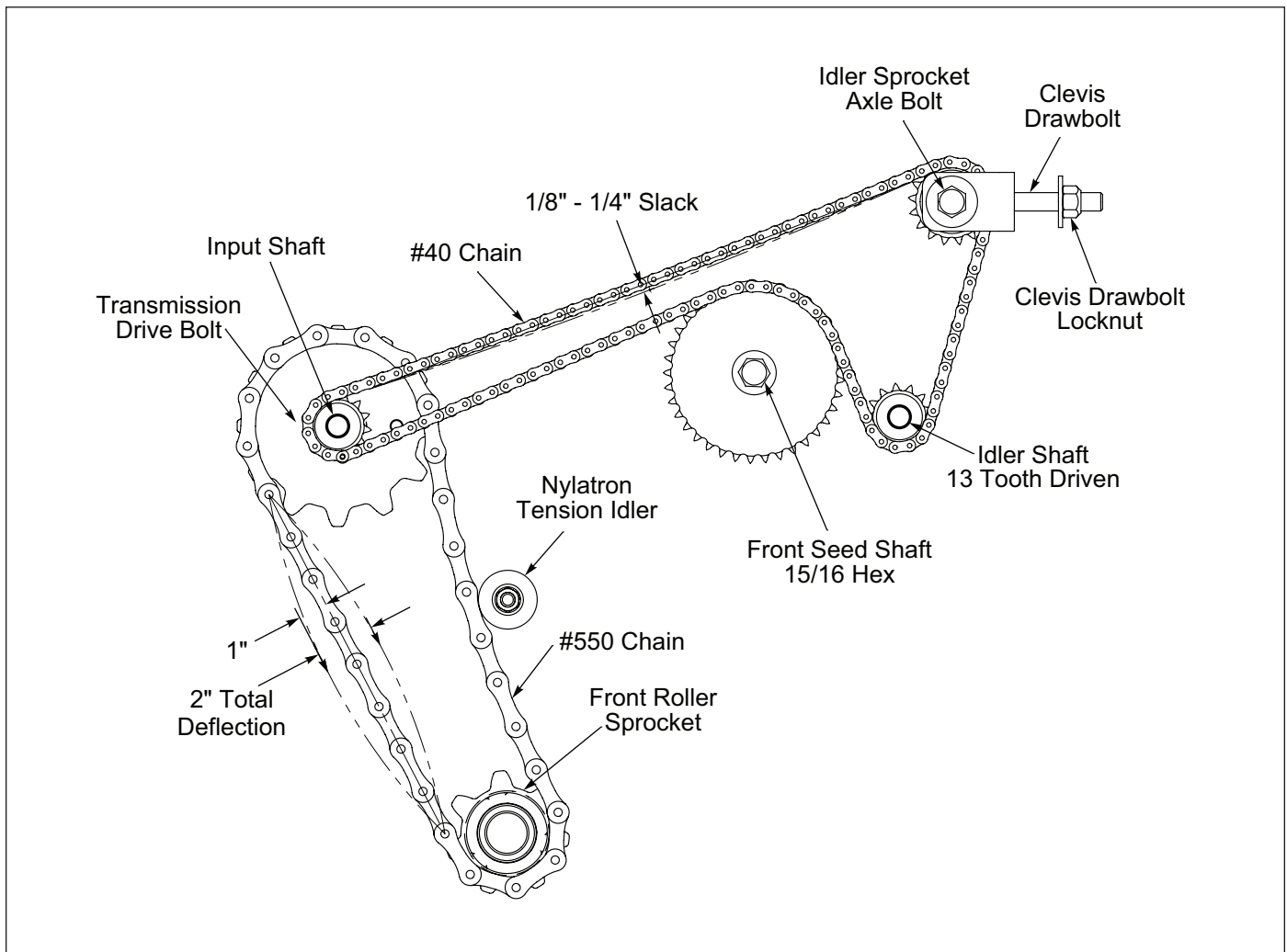
## Chain Tension

To adjust the Transmission Chain, loosen the 5/8" Idler Sprocket Axle Bolt and then adjust the Clevis Drawbolt Locknut to obtain about 1/8" - 1/4" sag. Re-tighten the Idler Sprocket Axle Bolt. Be careful not to over-tighten this chain. **See Figures 4-4 and 4-5.**

Adjust the #550 Chain between the Front Roller and Transmission by adjusting the Nylatron Tension Roller to allow approximately 2" of total chain deflection. **See Figure 4-5.**



**Figure 4-4: Loosen Idler Bolt**



**Figure 4-5: Chain Tension**

## Seed Meter Adjustment

### IMPORTANT

The Clutch must be disengaged when Seed Shafts are turned manually for Calibration.

### IMPORTANT

All the Seed Meters MUST BE CLOSED!

All Seed Meters must be set the same to ensure seeding uniformity. To check, set the Seed Rate Adjusting Nut to 0-A. The "A" on the Seed Rate Adjusting Nut is positioned over the "0" (the nut covers half of the "0") and snug against the Bearing. See Figure 4-6.

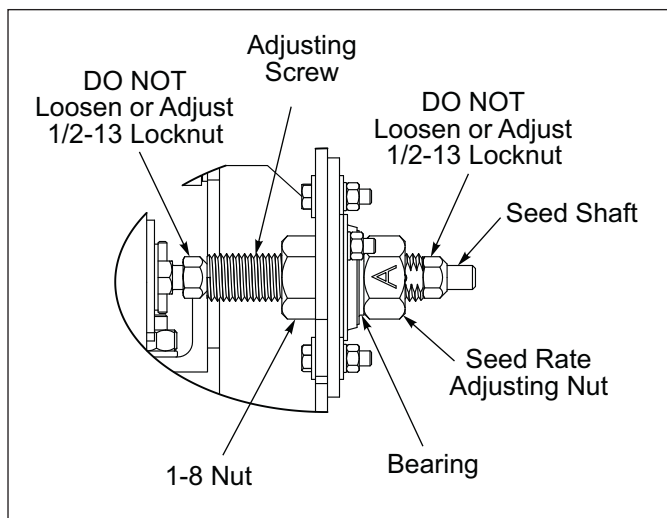


Figure 4-6: Seed Box Seed Rate Adjustment

All Seed Meters should be closed. Seed Meter Feed Shutoff against Seed Meter Cup Star Washer in Seed Meter Cup. See Figure 4-7. If not, there are three adjustments to make as needed.

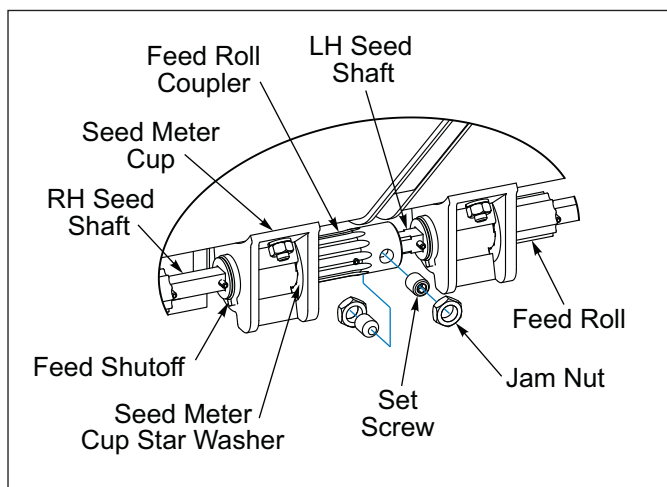


Figure 4-7: Seed Shaft Coupler

### IMPORTANT

Ensure the Seed Shaft can turn freely without any binding when the Seed Meters are open or closed after servicing.

- 1/2-13 Locknuts on both ends of the Adjusting Screw are used to adjust all Seed Meters the same amount. See Figure 4-6. To adjust Seed Meters to be closed at "0A", loosen 1/2-13 Locknuts and set Adjusting Screw to "0A". Slide Seed Shaft to close all Seed Meters. Tighten 1/2-13 Locknuts against Adjusting Screw.
- Seed Box Feed Roll Coupling which joins the left and right Seed Shafts changes Seed Meters on the left Seed Box in comparison with Seed Meters on the right Seed Box. To adjust Feed Roll Coupling, loosen Jam Nuts and Set Screws on Coupling RH Seed Shaft is treaded into Coupling. Turn RH Seed Shaft threading it in or out as needed to equalize Seed Meters. Re-tighten Set Screws against flat side on Seed Shaft, re-tighten Jam Nuts. See Figure 4-7.
- Individual Seed Meter Cups can be adjusted as required. Adjustments can be made by loosening the 1/4-20 x 5/8 Machine Screws that mount the Seed Meter Cup to the Seed Box. Adjust the affected Seed Meter Cup so the Feed Shutoff is against the Seed Meter Cup Star Washer in the Seed Meter Cup (closed). Be sure the Feed Roll stays engaged in the Seed Meter Cup Star Washer. See Figure 4-8.

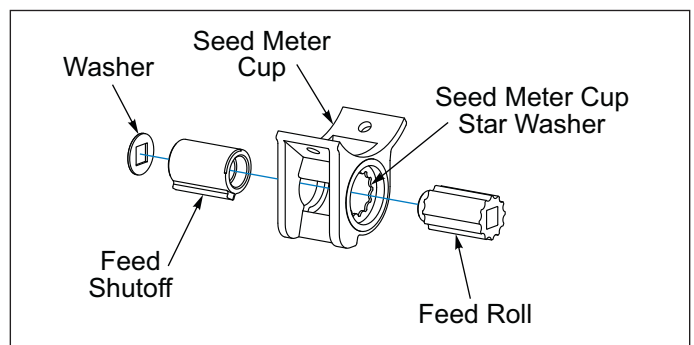


Figure 4-8: Small Seed Meter

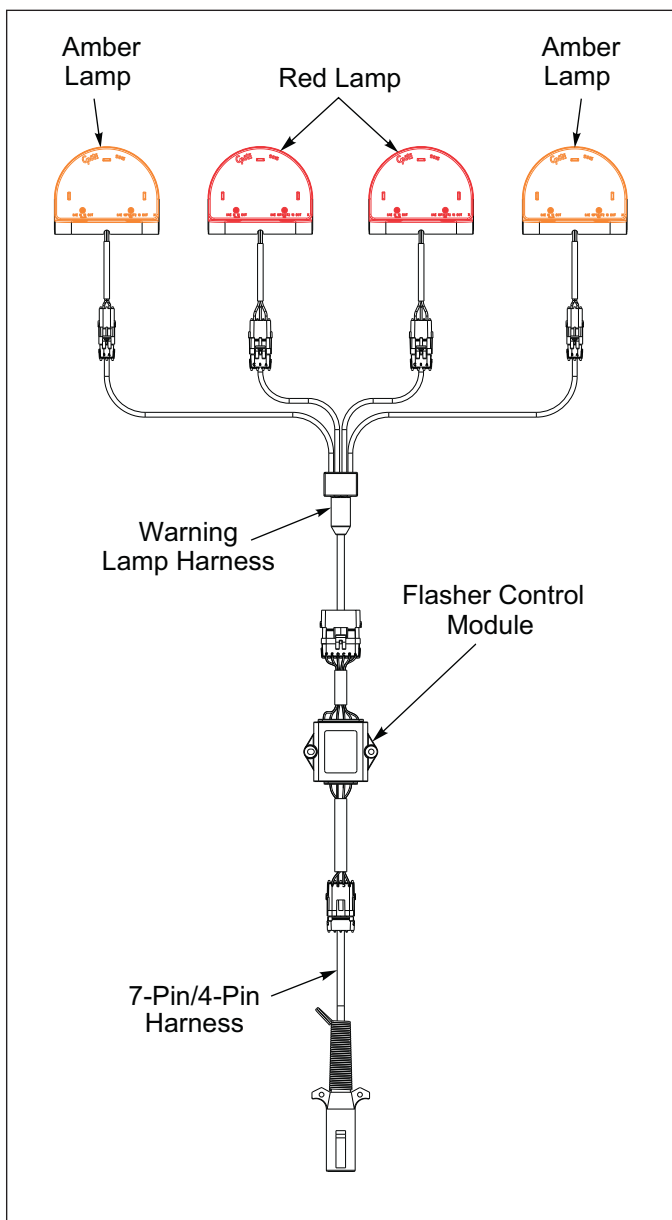


## LED Warning Lamps

When plugging in the Lamp 7-Pin Warning Lamp Connector:

1. Make sure the Tractor has a good clean Receptacle, free of dirt and corrosion.
2. Make sure the 7-Pin Connector is inserted ALL the way in. With tighter fitting pins, operator may think the Connector is all the way in, but it really isn't.
3. Make sure the Tractor Receptacle Cover latches over the keyway on the 7-Pin Connector to hold the Connector in place.

If an operator plugs in the 7-Pin Connector, but the lights do not seem to work right, check the above items to make sure there is a good connection with the 7-Pin Connector.



**Figure 4-9: LED Warning Lamps**



## Electric Clutch - Optional

### IMPORTANT

If your machine is equipped with an Electric Clutch at no time use high pressure water or air to clean it, as this can damage the unit.



Figure 4-10: High Pressure Warning

## Acre Meter Troubleshooting

### IMPORTANT

Acre Meter is dust and splash resistant, under no circumstances should this unit be submerged in any conductive, corrosive, or flammable liquid. At no time use high pressure water or air to clean it, as this can damage the unit. See Figure 4-10.

### NOTE

The ground wire is for static discharge protection and has no effect on the ability of the sensor to function properly under normal conditions.

The battery operated Acre Meter uses 3 AA batteries. The Acre Meter will display “LObat” when the batteries require replacement. Remove the Acre Meter from the machine and then the 4 Screws on the back of the case. Separate the housing from the rear plate. Replace with 3 quality AA batteries.

**Acre Meter does not count pulses during calibration or does not count acres during operation.**

1. Check the position of the Magnet Wheel Assembly and Pick-Up Switch against the set-up instructions in this manual. **See “Acre Meter Kit - Optional” on page 2-16.**
2. Verify that the magnet in the Magnet Wheel Assembly has not come out.
3. Place the Acre Meter display in “Calibrate” mode by pressing the **\*(FUNC)** key until the P-Word indicator is lit and then press the up/down arrow keys until the display shows 0 and the LED is blinking. Break the connection between the display and the Pick-up Switch and short between pins A and B on the

display harness connector. You should see the display increment +1 with each contact of the connector terminals.

4. If step 3 works then wave a magnet in front of the Pick-Up Switch face with it re-connected to the display and see if the display increments up. If not, put an ohm meter or continuity tester on the contacts of the Pick-Up Switch harness and place a magnet in front of the Pick-Up Switch face. The Pick-Up Switch should show continuity or near zero ohms resistance.

**Acre Meter cannot change the width or pulse count settings or clear the field and total acres.**

1. Check to see if a password needs to be entered by pressing the **\*(FUNC)** key until the P-Word indicator LED is lit. If “dis” is displayed (password disabled) no password is set.
2. If “Ent” is displayed a password must be entered to change the settings or the password must be disabled as instructed in the setup section of this manual.

## Storage

1. The service life of the Seeder will be extended by proper off-season storage practices. Prior to storing the unit, complete the following procedures:
  - Completely clean the unit, blow all seed out of Seed Meters.
  - Inspect the machine for worn or defective parts. Replace as needed.
  - Repaint all areas where the original paint is worn off.
  - Apply a light coating of oil or grease to exposed Cylinder Rods to prevent them from rusting.
  - Lubricate each point of the machine as stated in **“Lubrication Maintenance” on page 4-3.**
2. Store the unit in a shed or under a tarpaulin to protect it from the weather. The ground engaging components and Tires should rest on boards, or some other object, to keep them out of the soil.
3. 3-PT Hitch Models: Raise Track Removers, insert Parking Pin and Lower unit. Chock or block Roller Wheels before unhitching from Tractor.
4. Pull Type Models: Raise the machine and engage Transport Locks. **See Figure 3-5.** Lower Drawbar Jack.
  - Relieve Hydraulic Pressure in hoses after Transport Locks are installed.
  - Block Transport Wheels before unhitching from Tractor



**Specifications**

<b>Product Attributes</b>	<b>SS-108</b>	<b>SSP-108</b>
<b>Approximate Weight</b>	2,054 lbs. (924 kg)	1,734 lbs. (780 kg)
<b>Working Width</b>	8 ft. 0 in. (2.4 m)	8 ft. 0 in. (2.4 m)
<b>Transport Width</b>	11 ft. 1 in. (3.33 m)	9 ft. 6 in. (2.85 m)
<b>Transport Height</b>	5 ft. 2 in. (1.55 m)	Tractor Dependent
<b>Road Clearance</b>	10 in. (254 mm)	Tractor Dependent
<b>Overall Height</b>	3 ft. 8 in. (1.1 m)	3 ft. 8 in. (1.1 m)
<b>Overall Length</b>	10 ft. 1 in. (3.03 m)	4 ft. 10 in. (1.5 m)
<b>Seed Box</b>	All Steel Construction w/Cover	All Steel Construction w/Cover
<b>Seed Box Capacity - Meter Box</b>	6 bu.	6 bu.
<b>Seed Meters</b>	"Micro-Meter"	"Micro-Meter"
<b>Seed Meter Drive</b>	Ground Driven	Ground Driven
<b>Seed Meter Spacing</b>	4.25 in. (108 mm)	4.25 in. (108 mm)
<b>Seed Delivery</b>	Broadcast w/ Wind Deflector Tray	Broadcast w/ Wind Deflector Tray
<b>Pulverizer Roller - Front</b>	15.75 in. (400 mm) Gray Cast Iron	15.75 in. (400 mm) Gray Cast Iron
<b>Pulverizer Roller - Rear</b>	11.5 in. (292 mm) Gray Cast Iron	11.5 in. (292 mm) Gray Cast Iron
<b>Pulverizer Axle Bearings</b>	Greaseable	Greaseable
<b>Pulverizer Axle Size - Front</b>	12.75 in. (324 mm)	12.75 in. (324 mm)
<b>Pulverizer Axle Size - Rear</b>	8.625 in. (219 mm)	8.625 in. (219 mm)
<b>Hitch</b>	Pull-Type with Hydraulic Transport	Three-Point Hitch - Cat. II Free Link; Cat. II, IIIN Quick Coupler Hitch
<b>Hydraulic Equipment</b>	Cylinders w/Hoses to Hitch Point	N/A
<b>Tire Size</b>	9.5L x 15-8 Ply Implement Rib	N/A
<b>S-Tine Wheel Track Remover</b>	Optional	Optional
<b>Coil Tine Track Remover</b>	Optional	Optional
<b>Front Roller Scraper Kit</b>	Optional	Optional
<b>Electronic Acre Meter</b>	Optional	Optional
<b>Factory Installed Electric Clutch</b>	Optional	Optional
<b>Seed Shaft Monitor Kit</b>	Optional	Optional
<b>Short Coupled Three-Point Hitch</b>	N/A	Optional
<b>Safety Warning Lights &amp; SMV Emblem</b>	Standard	Standard
<b>Safety Chain Kit</b>	Standard	N/A
<b>Powder Coat Paint, Red</b>	Standard	Standard
<b>Horsepower Requirements</b>	6 to 8 HP (4.5 to 6 kW) per ft.	6 to 8 HP (4.5 to 6 kW) per ft.
<b>Recommended Operating Speed</b>	3 to 6 MPH (5 to 10 km/h)	3 to 6 MPH (5 to 10 km/h)

*Specifications subject to change with or without notice*

**Table 5-1: Model Specifications, 8FT**

## TABLE OF CONTENTS

### SPECIFICATIONS

Product Attributes	SS-110	SSP-110
Approximate Weight	2,394 lbs. (1,077 kg)	2,074 lbs. (933 kg)
Working Width	10 ft. 0 in. (3.0 m)	10 ft. 0 in. (3.0 m)
Transport Width	12 ft. 11 in. (3.88 m)	11 ft. 4 in. (3.4 m)
Transport Height	5 ft. 2 in. (1.55 m)	Tractor Dependent
Road Clearance	10 in. (254 mm)	Tractor Dependent
Overall Height	3 ft. 8 in. (1.1 m)	3 ft. 8 in. (1.1 m)
Overall Length	10 ft. 1 in. (3.03 m)	4 ft. 10 in. (1.5 m)
Seed Box	All Steel Construction w/Cover	All Steel Construction w/Cover
Seed Box Capacity - Meter Box	7.5 bu.	7.5 bu.
Seed Meters	"Micro-Meter"	"Micro-Meter"
Seed Meter Drive	Ground Driven	Ground Driven
Seed Meter Spacing	4.25 in. (108 mm)	4.25 in. (108 mm)
Seed Delivery	Broadcast w/ Wind Deflector Tray	Broadcast w/ Wind Deflector Tray
Pulverizer Roller - Front	15.75 in. (400 mm) Gray Cast Iron	15.75 in. (400 mm) Gray Cast Iron
Pulverizer Roller - Rear	11.5 in. (292 mm) Gray Cast Iron	11.5 in. (292 mm) Gray Cast Iron
Pulverizer Axle Bearings	Greaseable	Greaseable
Pulverizer Axle Size - Front	12.75 in. (324 mm)	12.75 in. (324 mm)
Pulverizer Axle Size - Rear	8.625 in. (219 mm)	8.625 in. (219 mm)
Hitch	Pull-Type w/Hydraulic Transport	Three-Point Hitch - Cat. II Free Link; Cat. II, IIIN Quick Coupler Hitch
Hydraulic Equipment	Cylinders w/Hoses to Hitch Point	N/A
Tire Size	9.5L x 15-8 Ply Implement Rib	N/A
S-Tine Wheel Track Remover	Optional	Optional
Coil Tine Track Remover	Optional	Optional
Front Roller Scraper Kit	Optional	Optional
Electronic Acre Meter	Optional	Optional
Factory Installed Electric Clutch	Optional	Optional
Seed Shaft Monitor Kit	Optional	Optional
Short Coupled Three-Point Hitch	N/A	Optional
Safety Warning Lights & SMV Emblem	Standard	Standard
Safety Chain Kit	Standard	N/A
Powder Coat Paint, Red	Standard	Standard
Horsepower Requirements	6 to 8 HP (4.5 to 6 kW) per ft.	6 to 8 HP (4.5 to 6 kW) per ft.
Recommended Operating Speed	3 to 6 MPH (5 to 10 km/h)	3 to 6 MPH (5 to 10 km/h)

*Specifications subject to change with or without notice.*

**Table 5-2: Model Specifications, 10FT**

<b>Product Attributes</b>	<b>SS-112</b>	<b>SSP-112</b>
<b>Approximate Weight</b>	2,842 lbs. (1,279 kg)	2,488 lbs. (1,120 kg)
<b>Working Width</b>	12 ft. 0 in. (3.6 m)	12 ft. 0 in. (3.6 m)
<b>Transport Width</b>	15 ft. 0 in. (4.5 m)	13 ft. 3 in. (3.98 m)
<b>Transport Height</b>	5 ft. 2 in. (1.55 m)	Tractor Dependent
<b>Road Clearance</b>	10 in. (254 mm)	Tractor Dependent
<b>Overall Height</b>	3 ft. 8 in. (1.1 m)	3 ft. 8 in. (1.1 m)
<b>Overall Length</b>	10 ft. 1 in. (3.03 m)	4 ft. 10 in. (1.5 m)
<b>Seed Box</b>	All Steel Construction w/Cover	All Steel Construction w/Cover
<b>Seed Box Capacity - Meter Box</b>	9.0 bu.	9.0 bu.
<b>Seed Meters</b>	"Micro-Meter"	"Micro-Meter"
<b>Seed Meter Drive</b>	Ground Driven	Ground Driven
<b>Seed Meter Spacing</b>	4.25 in. (108 mm)	4.25 in. (108 mm)
<b>Seed Delivery</b>	Broadcast w/ Wind Deflector Tray	Broadcast w/ Wind Deflector Tray
<b>Pulverizer Roller - Front</b>	15.75 in. (400 mm) Gray Cast Iron	15.75 in. (400 mm) Gray Cast Iron
<b>Pulverizer Roller - Rear</b>	11.5 in. (292 mm) Gray Cast Iron	11.5 in. (292 mm) Gray Cast Iron
<b>Pulverizer Axle Bearings</b>	Greaseable	Greaseable
<b>Pulverizer Axle Size - Front</b>	12.75 in. (324 mm)	12.75 in. (324 mm)
<b>Pulverizer Axle Size - Rear</b>	8.625 in. (219 mm)	8.625 in. (219 mm)
<b>Hitch</b>	Pull-Type w/Hydraulic Transport	Three-Point Hitch - Cat. II Free Link; Cat. II, IIIN Quick Coupler Hitch
<b>Hydraulic Equipment</b>	Cylinders w/Hoses to Hitch Point	N/A
<b>Tire Size</b>	9.5L x 15-8 Ply Implement Rib	N/A
<b>S-Tine Wheel Track Remover</b>	Optional	Optional
<b>Coil Tine Track Remover</b>	Optional	Optional
<b>Front Roller Scraper Kit</b>	Optional	Optional
<b>Electronic Acre Meter</b>	Optional	Optional
<b>Factory Installed Electric Clutch</b>	Optional	Optional
<b>Seed Shaft Monitor Kit</b>	Optional	Optional
<b>Short Coupled Three-Point Hitch</b>	N/A	Optional
<b>Safety Warning Lights &amp; SMV Emblem</b>	Standard	Standard
<b>Safety Chain Kit</b>	Standard	N/A
<b>Powder Coat Paint, Red</b>	Standard	Standard
<b>Horsepower Requirements</b>	6 to 8 HP (4.5 to 6 kW) per ft.	6 to 8 HP (4.5 to 6 kW) per ft.
<b>Recommended Operating Speed</b>	3 to 6 MPH (5 to 10 km/h)	3 to 6 MPH (5 to 10 km/h)

*Specifications subject to change with or without notice.*

**Figure 5-1: Model Specifications, 12FT**



## Document Control Revision Log:

Date	Form #	Improvement(s): Description and Comments
07/07/2008	205rev7-7-08	Initial Release
09/2013	205rev0913	Added LED Warning Lights
12/2015	205rev1215	Added Seed Box Dividers, moved Decals
06/2021	9K713-0621	ECN 47093 - Hub & Spindle Asm Update to 6 Bolt



---

# Intertek

Equipment from Landoll Company, LLC is built to exacting standards ensured by ISO 9001 registration at all Landoll manufacturing facilities.

## **Mid-Size Sure Stand Seeder Model SS108/SS110/SS112 SSP108/SSP110/SSP112**

### **Operator's Manual**

## **Re-Order Part Number 9K713**

**LANDOLL COMPANY, LLC**

1900 North Street

Marysville, Kansas 66508

(785) 562-5381

800-428-5655 ~ **WWW.LANDOLL.COM**



Copyright 2021. Landoll Company, LLC

“All rights reserved, including the right to reproduce this material or portions thereof in any form.”

