

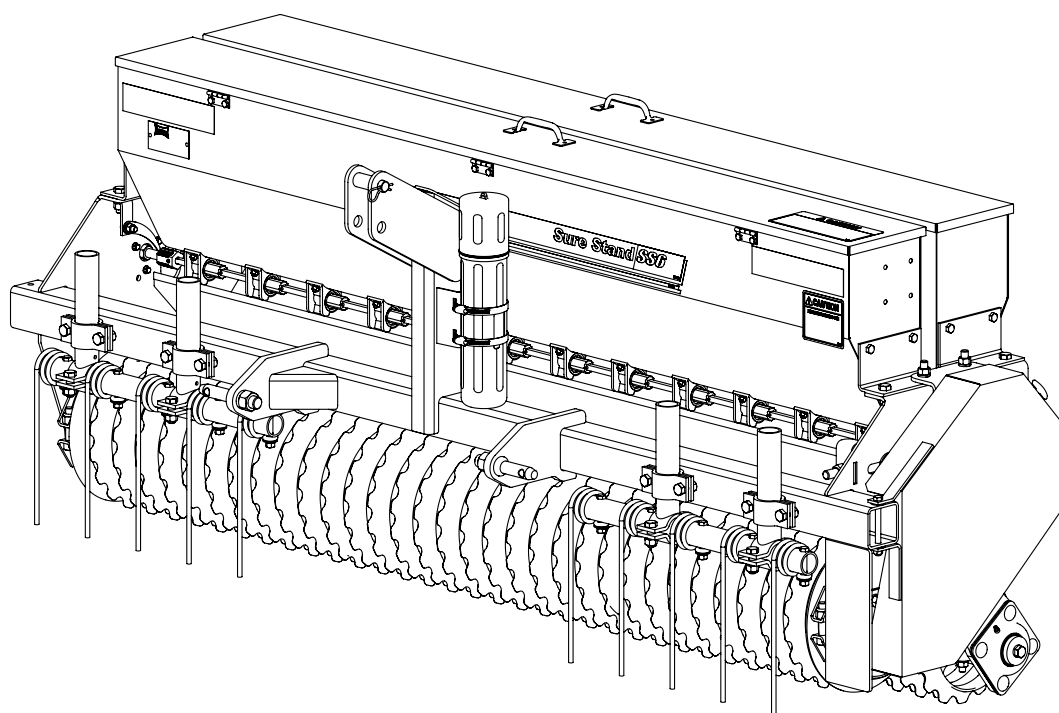

Sure Stand Seeder Models SSP4, SSP5 and SSP6 Parts Manual



LANDOLL COMPANY, LLC

1900 North Street

Marysville, Kansas 66508

(785) 562-5381

800-428-5655 ~ WWW.LANDOLL.COM

Manuals for Sure Stand Seeder - SSP4, SSP5, SSP6

Manual Number	Manual Type
7K555	Operator's Manual
7K554	Parts Manual

Table of Contents

1 Illustrated Parts List

Instructions for Ordering Parts	1-1
SSP4 and SSP5 Frame with 3 Point Hitch and Mounting Hardware	1-2
SSP6 Frame with 3 Point Hitch and Mounting Hardware	1-4
Wheel and Axle Assemblies	1-6
Drive Sprockets and Chain Assembly	1-8
Right End Components	1-11
Front Seedbox	1-12
Rear Agitator Seedbox	1-14
Coil Tine Wheel Track Remover 4' and 5'	1-18
Coil Tine Wheel Track Remover 6'	1-19
Electric Acre Meter Assembly	1-20
CAT2 Quick Coupler Hitch Adaptor - Optional	1-22
Lift Sling Kits	1-23
Decals	1-24
Decal Locations	1-26

2 Glossary

3 Index

Illustrated Parts List

Instructions for Ordering Parts

**** Repair parts must be ordered through an authorized dealer ****

DEALER INSTRUCTIONS FOR ORDERING PARTS FROM LANDOLL PARTS DISTRIBUTION CENTER

PHONE #: 800-423-4320 OR 785-562-5381

FAX #: 888-527-3909

ORDER ONLINE: Dealer.landoll.com

IDENTIFICATION PLATE

See Figure 1-1 for the Identification Plate, which lists the model and serial number of the equipment. It is located on the right side of the Sure Stand Seeder.

SERIAL NUMBER NOMENCLATURE

The serial number for the Sure Stand Seeder is located on the identification plate. The following information will help decode the Landoll serial number.

ASD21000100=xxmyysss

xx	= model series (i.e. "AS" for all AG Seeders)
m	= month of manufacture (ex. "D" means April. The letter I is not used.)
yy	= last digits of the year manufactured (ex. "21" means 2021)
sss	= Sequential number used to track warranty and service information.

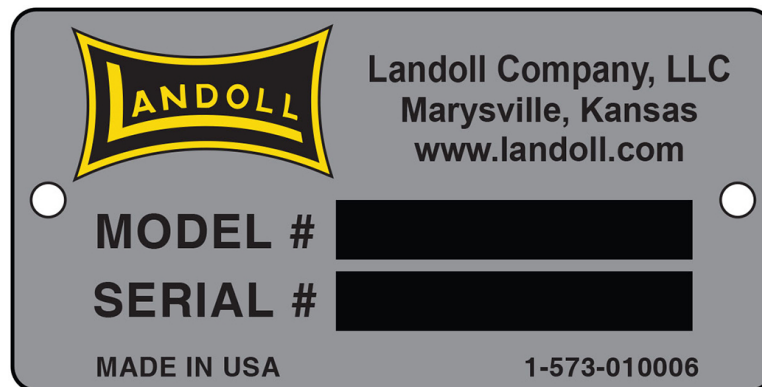

Figure 1-1: Identification Plate

SSP4 and SSP5 Frame with 3 Point Hitch and Mounting Hardware

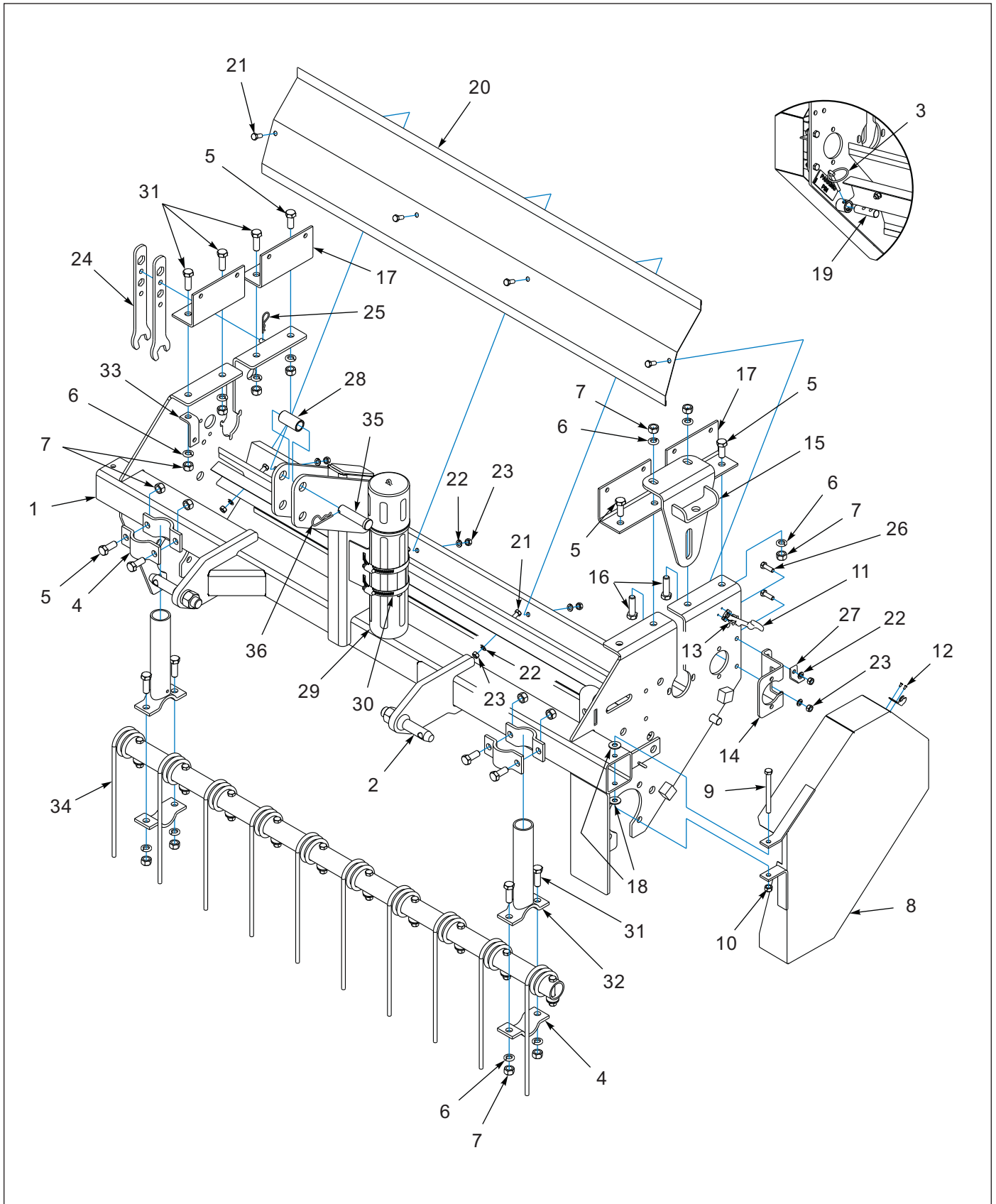

Figure 1-2: SSP4 and SSP5 Frame with 3 Point Hitch and Mounting Hardware

SSP4 and SSP5 Frame with 3 Point Hitch and Mounting Hardware

ITEM	PART NUMBER	DESCRIPTION	QTY	
			4'	5'
1	6K862	SSP4/SLP304 FRAME	1	--
1	8K495	SSP5 FRAME	--	1
2	6K010	HITCH PIN W/ NUT & LOCKWASHER	2	2
3	1-557-010327	KLIK PIN, 1/4"	1	1
4	2K656	CLAMP	4	4
5	1-654-010055-02	CAPSCREW, 1/2-13 NC X 1-1/4", GR5	7	7
6	1-861-010034-13	LOCKWASHER, 1/2"	12	12
7	1-512-010007-09	NUT, 1/2-13 NC	16	16
8	6K056	GUARD 4'-5'-6' TURF SEEDERS	1	1
9	108295	CAPSCREW, 3/8-16 NC X 4", GR5	1	1
10	1-512-010005-05	NUT, SELF-LOCKING, 3/8-16 NC	1	1
11	6K057	RUBBER LATCH, 3" T-HANDLE	1	1
12	107-0814	BLIND RIVET, 1/8" DIA. X 1/8" GRIP	2	2
13	51365-4	BLIND RIVET, 1/8" DIA. X 3/8" GRIP	2	2
14	7K420	BRACKET	1	1
15	7K418	IDLER BRACKET	1	1
16	1-654-010055-04	CAPSCREW, 1/2-13 NC X 1 3/4" GR5	2	2
17	7K419	MOUNTING BRACKET	4	4
18	1-861-010032-11	WASHER, FLT 3/8 STD ZP	2	2
19	9J457	PIN, 5/8" X 2 5/16"	1	1
20	7K451	DEFLECTOR, 4 FT MACHINE	2	--
20	8K496	DEFLECTOR, 5 FT MACHINE	--	2
21	1-654-010049-03	CAPSCREW, 5/16-18 NC X 3/4"	8	8
22	1-861-010034-10	LOCKWASHER, 5/16"	10	10
23	1-512-010007-06	NUT, 5/16-18 NC	10	10
24	6K032	WRENCH, 15/16"	2	2
25	6C400	HAIRPIN COTTER	1	1
26	1-654-010049-05	CAPSCREW, 5/16-18 NC X 1"	2	2
27	7K590	CLIP	1	1
28	7K229	SLEEVE- 1 OD X 2 LG	1	1
29	1-116-010019	MANUAL STORAGE CANNISTER, 14"	1	1
30	105-0093	HOSE CLAMP, #56 STAINLESS	2	2
31	1-654-010055-03	HHCS, 1/2-13 NC X 1 1/2", GR5	7	7
32	6K026	TINE SUPPORT	2	2
33	7K442	BRACKET	1	1
34	6K083	PIPE & TINE ASSY- 4' (SEE PAGE 1-18)	1	--
34	8K600	PIPE & TINE ASSY- 5' (SEE PAGE 1-18)	--	1
35	7D642	CLEVIS PIN (3/4 X 3)	1	1
36	6J448	HAIR PIN COTTER	1	1

SSP6 Frame with 3 Point Hitch and Mounting Hardware

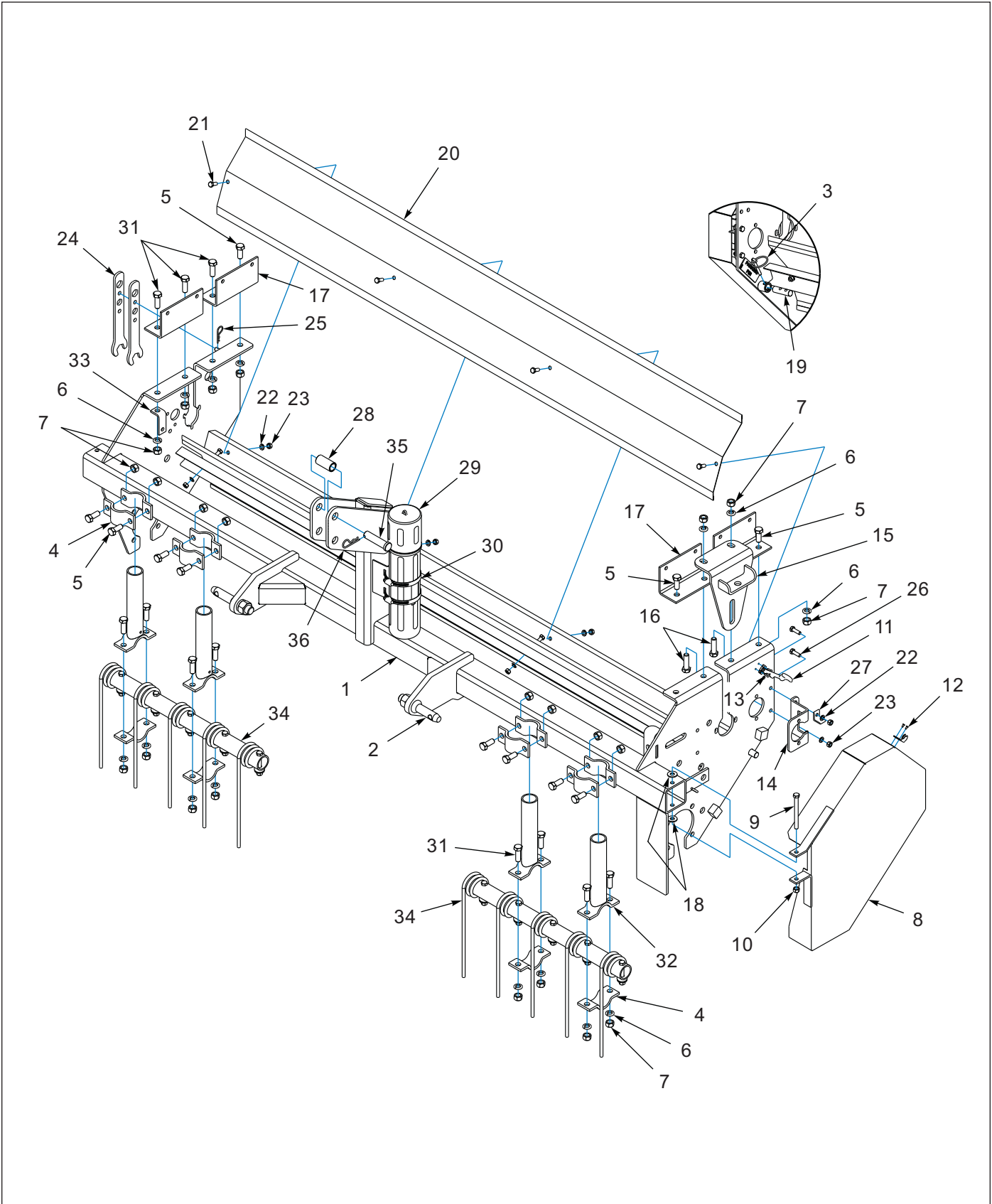

Figure 1-3: SSP6 Frame with 3 Point Hitch and Mounting Hardware

SSP6 Frame with 3 Point Hitch and Mounting Hardware

ITEM	PART NUMBER	DESCRIPTION	QTY
1	6K861	SSP6/SLP306 FRAME	1
2	6K010	HITCH PIN W/ NUT & LOCKWASHER	2
3	1-557-010327	KLIK PIN, 1/4"	1
4	2K656	CLAMP	8
5	1-654-010055-02	CAPSCREW, 1/2-13 NC X 1-1/4", GR5	11
6	1-861-010034-13	LOCKWASHER, 1/2"	16
7	1-512-010007-09	NUT, 1/2-13 NC	24
8	6K056	GUARD	1
9	108295	CAPSCREW, 3/8-16 NC X 4", GR5	1
10	1-512-010005-05	NUT, SELF-LOCKING, 3/8-16 NC	1
11	6K057	RUBBER LATCH, 3" T-HANDLE	1
12	107-0814	BLIND RIVET, 1/8" DIA. X 1/8" GRIP	2
13	51365-4	BLIND RIVET, 1/8" DIA. X 3/8" GRIP	2
14	7K420	BRACKET	1
15	7K418	IDLER BRACKET	1
16	1-654-010055-04	CAPSCREW, 1/2-13 NC X 1 3/4" GR5	2
17	7K419	MOUNTING BRACKET	4
18	1-861-010032-11	WASHER, FLT 3/8 STD ZP	2
19	9J457	PIN, 5/8" X 2 5/16"	1
20	7K348	DEFLECTOR, 6 FT MACHINE	2
21	1-654-010049-03	CAPSCREW, 5/16-18 NC X 3/4"	8
22	1-861-010034-10	LOCKWASHER, 5/16"	2
23	1-512-010007-06	NUT, 5/16-18 NC	10
24	6K032	WRENCH, 15/16"	10
25	6C400	HAIRPIN COTTER	1
26	1-654-010049-05	CAPSCREW, 5/16-18 NC X 1"	2
27	7K590	CLIP	1
28	7K229	SLEEVE - 1 OD X 2 LG	1
29	1-116-010019	MANUAL STORAGE CANNISTER, 14"	4
30	105-0093	HOSE CLAMP, #56 STAINLESS	1
31	1-654-010055-03	HHCS, 1/2-13 NC X 1 1/2", GR5	11
32	6K026	TINE SUPPORT	1
33	7K442	BRACKET	1
34	6K027	6' PIPE & TINE ASSY (SEE PAGE 1-19)	2
35	7D642	CLEVIS PIN (3/4 X 3)	1
36	6J448	HAIR PIN COTTER	1

Wheel and Axle Assemblies

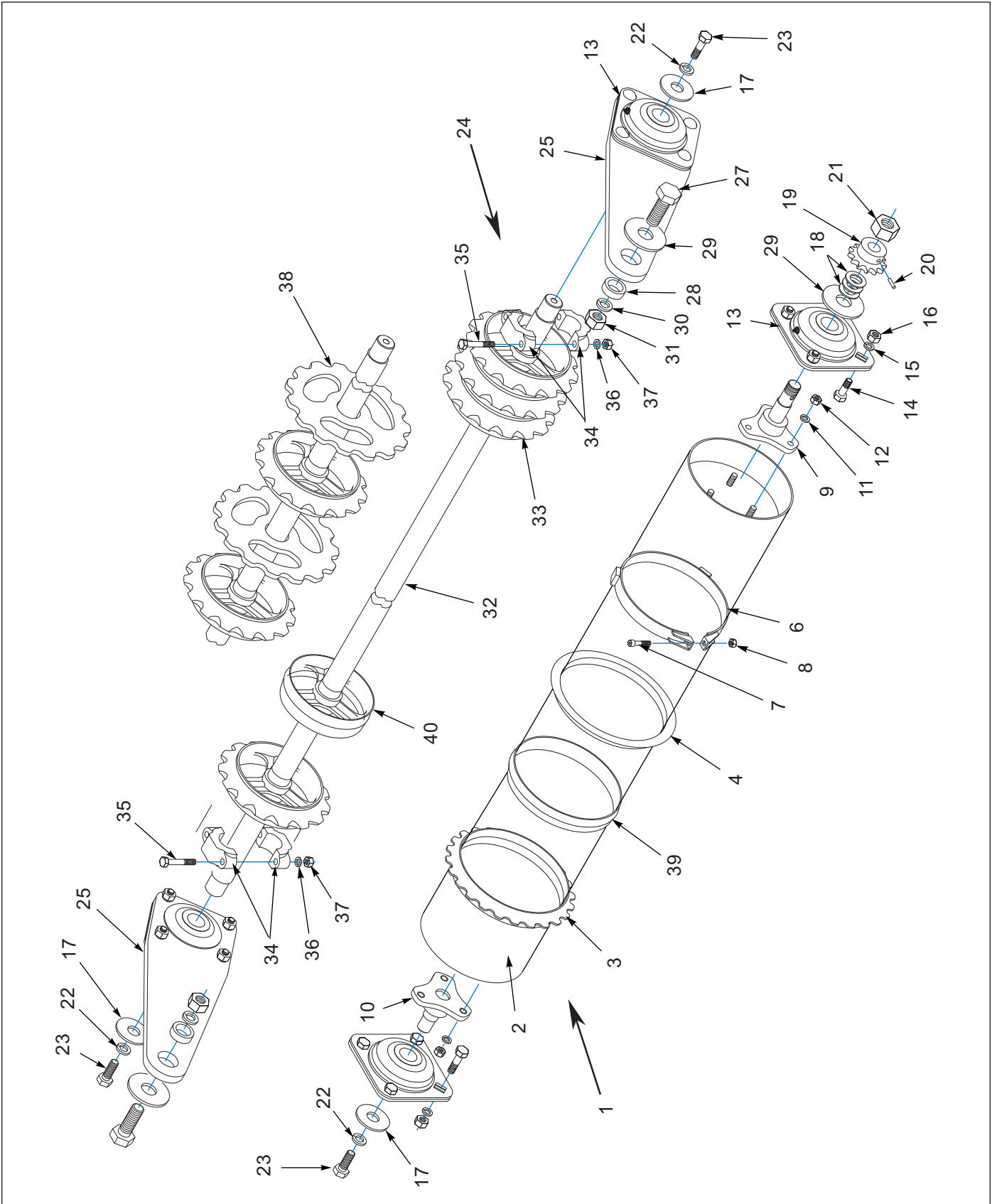

Figure 1-4: Wheel and Axle Assemblies

Wheel and Axle Assemblies

ITEM	PART NUMBER	DESCRIPTION	QTY		
			4'	5'	6'
1	6K072	FRONT ROLLER ASSY - 4'	1	--	--
1	8K488	5' FRONT ROLLER ASSY	--	1	--
1	6K012	FRONT ROLLER ASSY - 6'	--	--	1
2	6K073	FRONT PIPE & PLATE ASSEMBLY	1	--	--
2	8K489	FRONT PIPE & PLATE ASSEMBLY	--	1	--
2	6K014	FRONT PIPE & PLATE ASSEMBLY	--	--	1
3	4C689	SAND WHEEL	20	26	31
4	2C524	END WHEEL	2	2	2
6	2C801	CLAMP BAND ASSEMBLY (INCLUDES ITEMS 7 AND 8)	2	2	2
7	4C144	SOCKET HEAD CAPSCREW, 1/2" X 2 1/4"	2	2	2
8	2C112	LOCK NUT, 1/2" HEX	2	2	2
9	6K812	STUB SHAFT - LEFT	1	1	1
10	2K475	STUB SHAFT - RIGHT	1	1	1
11	1-861-010034-15	LOCKWASHER, 5/8"	6	6	6
12	1-512-010007-11	NUT, 5/8"	6	6	6
13	1-065-010011	BEARING ASSEMBLY	2	2	2
14	1-654-010055-03	CAPSCREW, 1/2-13 NC X 1 1/2" Gr5	8	8	8
15	1-861-010034-13	LOCKWASHER, 1/2"	16	16	16
16	1-512-010007-09	NUT, 1/2-13 NC	16	16	16
17	9J338	WASHER, 17/32" ID X 2" OD X 3/8"	3	3	3
18	8C381	MACHINERY BUSHING, 3/4" ID X 1 1/4" OD X #14	3	3	3
19	9D772	SPROCKET, 13 TOOTH	1	1	1
20	1-647-010004217	ROLL PIN, 1/4" X 1 1/2"	1	1	1
21	119083	JAM NUT, 3/4-10 NC	1	1	1
22	1-861-010034-13	LOCKWASHER, 1/2"	3	3	3
23	104665	CAPSCREW, 1/2-20 NF X 1 1/4" Gr5	3	3	3
24	6K070	REAR ROLLER ASSEMBLY	1	--	--
24	8K491	REAR ROLLER ASSEMBLY	--	1	--
24	6K015	REAR ROLLER ASSEMBLY	--	--	1
25	6K017	REAR ARM ASSEMBLY	2	2	2
26	9J559	CARRIAGE BOLT, 1/2-13 NC X 1 1/2" Gr5	8	8	8
27	1-654-010061-05	CAPSCREW, 3/4-10 NC X 2" Gr5	2	2	2
28	9J399	BUSHING	2	2	2
29	1-861-010032-21	FLAT WASHER, 3/4"	3	3	3
30	1-861-010034-17	LOCKWASHER, 3/4"	3	3	3
31	1-512-010007-12	NUT, 3/4-10 NC	2	2	2
32	6K071	SHAFT - 4 FT MACHINE	1	--	--
32	8K492	SHAFT - 5 FT MACHINE	--	1	--
32	6K016	SHAFT - 6 FT MACHINE	--	--	1
33	5C284	SAND WHEEL	21	27	32
34	4C145	CLAMP	4	4	4
35	7C783	CAPSCREW, 7/16" X 3" Gr5	4	--	--
36	1C314	LOCKWASHER, 7/16"	4	--	--
37	1C179	HEX NUT, 7/16"	4	--	--
38	6K066	SPROCKET (OPTIONAL)	19	24	28
39	4C140	SMOOTH WHEEL, FRONT (OPTIONAL)	20	26	31
40	3C955	SMOOTH WHEEL, REAR (OPTIONAL)	21	27	32

Drive Sprockets and Chain Assembly

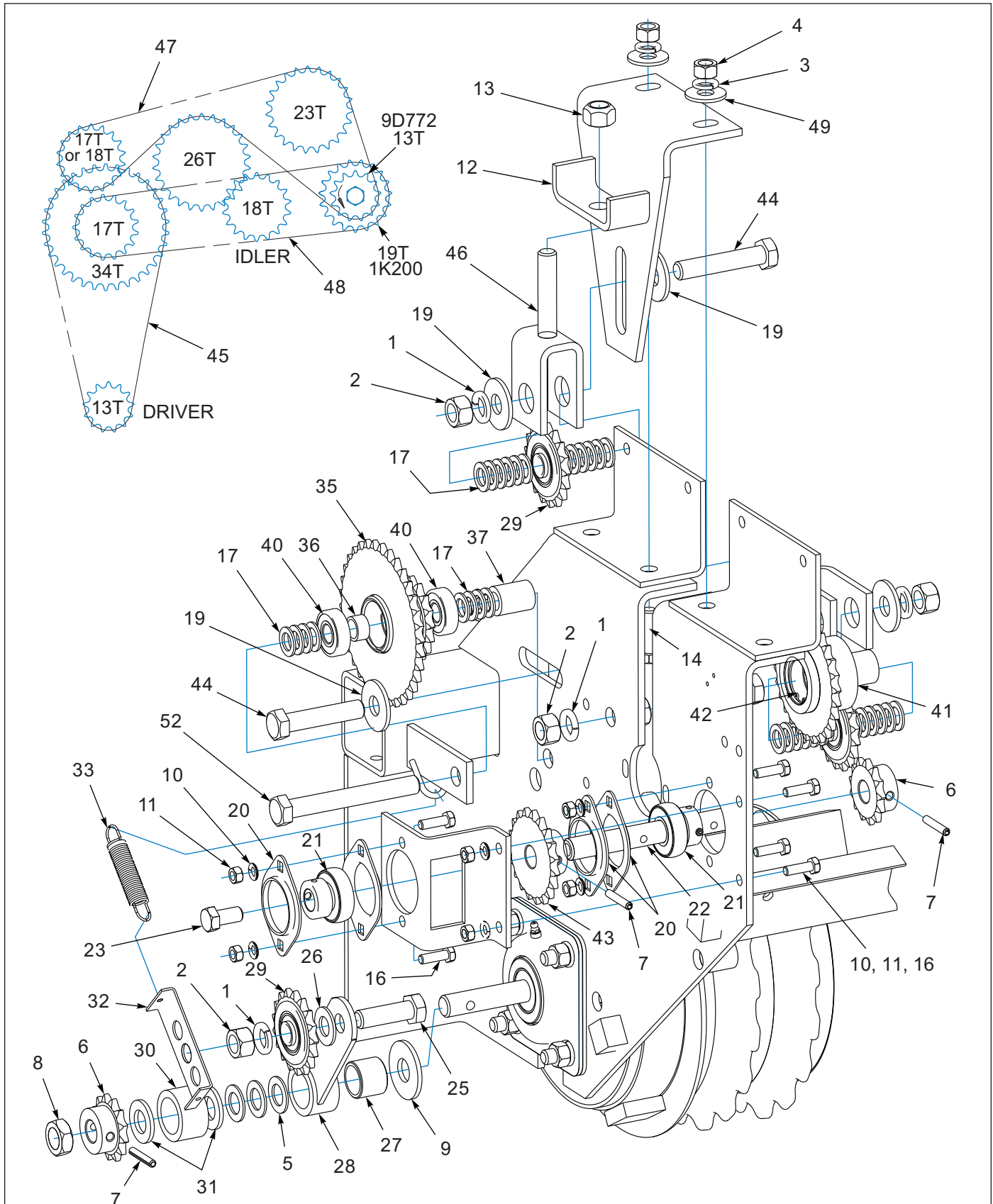

Figure 1-5: Drive Sprockets and Chain Assembly (1 of 2)

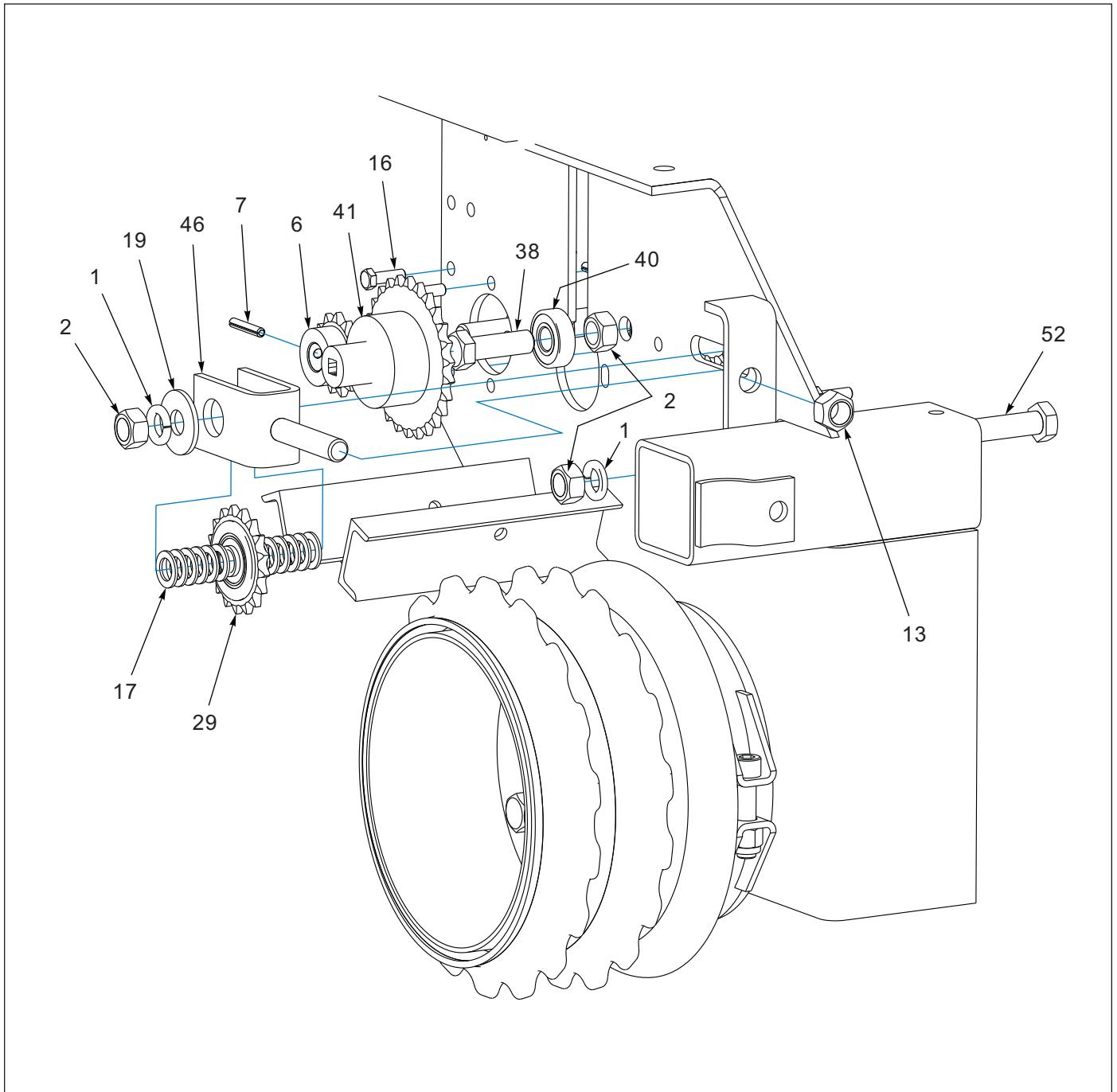

Figure 1-6: Drive Sprockets and Chain Assembly (2 of 2)

Drive Sprockets and Chain Assembly

ITEM	PART NUMBER	DESCRIPTION	QTY
1	1-861-010034-15	LOCKWASHER, 5/8"	8
2	1-512-010007-11	HEX NUT, 5/8-11 NC" REG. HEX	8
3	1-861-010034-13	LOCKWASHER, 1/2"	8
4	1-512-010007-09	HEX NUT, 1/2-13 NC REG. HEX	8
5	8C381	MACHINERY BUSHING, 1 1/4"OD; 14 GA.	4
6	9D772	SPROCKET, 13 TOOTH	2
7	1-647-010004217	ROLL PIN, 1/4" X 1 1/2"	3

Drive Sprockets and Chain Assembly

ITEM	PART NUMBER	DESCRIPTION	QTY
8	119083	JAM NUT, 3/4-10 NC	1
9	1-861-010032-21	FLAT WASHER, 3/4"	6
10	1-861-010034-10	LOCKWASHER, 5/16"	6
11	1-512-010007-06	HEX NUT, 5/16-18 NC REG. HEX	6
12	7K418	IDLER BRACKET	1
13	1-512-010005-13	LOCK NUT, 5/8"	2
14	1-654-010055-04	CAPSCREW, 1/2-13 NC X 1 3/4", GR5	5
15	7K420	BRACKET	1
16	1-654-010049-05	CAPSCREW, 5/16-18 NC X 1", GR5	6
17	8C892	MACHINERY BUSHING, 5/8" OD; 14 GA.	34
19	1-861-010032-19	FLAT WASHER, 5/8"	7
20	2K503	FLANGETTE HALF	4
21	1D598	BEARING AND COLLAR	2
22	6K378	SHAFT	1
23	5C516	CAPSCREW, 1/2-13 NC X 1" LH, GR2	1
25	5C460	HHCS, 5/8-11 NC X 2". GR5	1
26	5C907	FLAT WASHER, 5/8" SAE	1
27	6J195	BUSHING	1
28	6K815	IDLER ARM	1
29	117721	IDLER SPROCKET, 18-TOOTH	1
30	6K842	SPACER	1
31	1-861-010032-20	FLAT WASHER, 3/4" SAE	2
32	6K856	SPRING CLIP	1
33	6K868	SPRING	1
34	6K749	SPROCKET ASSEMBLY SLOW DOWN (INCLUDES ITEMS 35,36,40)	1
35	6K730	DOUBLE SPROCKET	1
36	7K113	SPACER	1
37	7K118	SPACER	1
38	6D476	CAPSCREW, 5/8-11 NC X 2 1/4", GR5	1
40	7K114	BALL BEARING, 5/8" BORE	1
41	7K423	SPROCKET AND HUB, 26 TOOTH	1
42	7K439	RETAINING RING	1
43	1K200	SPROCKET, 19 TOOTH	1
44	1-654-010059-09	CAPSCREW, 5/8-11 NC X 3", GR5	2
45	6K820	ROLLER CHAIN #40 X 57 PITCHES	1
46	9J379	YOKE	2
47	7K438	ROLLER CHAIN #40 X 72 PITCHES	1
48	7K436	ROLLER CHAIN #40 X 64 PITCHES	1
49	1-861-010032-15	FLAT WASHER, 1/2" STD	2
51	7K590	CLIP	1
52	6D305	HHCS, 5/8-11 NC X 5", GR5	1
53	9J301	DECAL, PARKING PIN	1
54	6K816	IDLER ARM ASSEMBLY (INCLUDES ITEMS 1,2,25-33)	1
55	6K817	DOUBLE SPROCKET ASSEMBLY (INCLUDES ITEMS 1,2,17,34-36)	1
56	7K429	SPROCKET ASSEMBLY, 26 TOOTH (INCLUDES ITEMS 2,37-41)	1

Right End Components

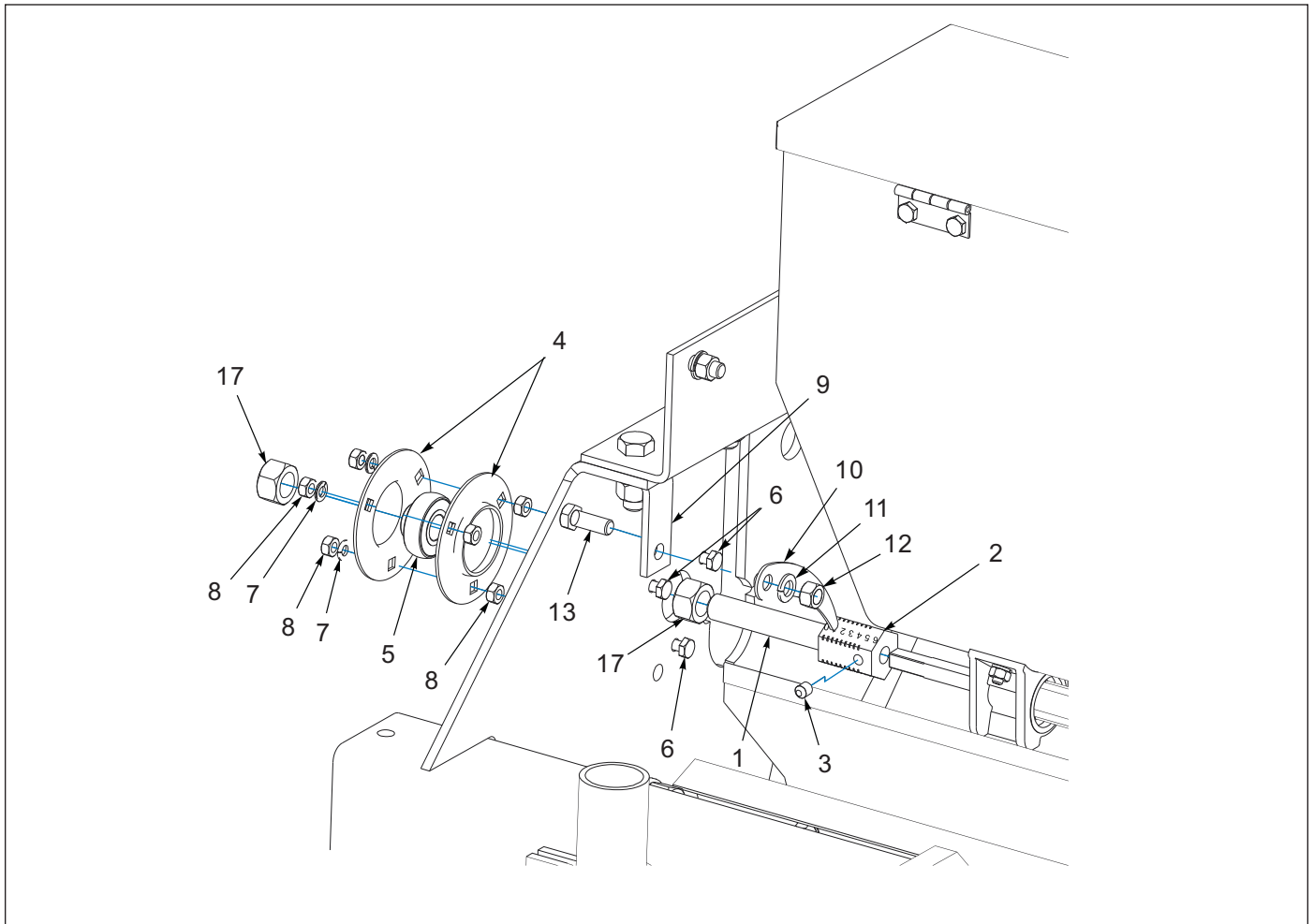

Figure 1-7: Right End Components

Right End Components

ITEM	PART NUMBER	DESCRIPTION	QTY
1	6K391	SEED SHAFT EXTENTION	1
2	6K443	NUMBER DECAL	3
3	107-0975	SET SCREW, 5/16-18 NC X 3/8", SOCKET CUP	1
4	9D816	FLANGETTE	2
5	5K989	BEARING	1
6	7K237	HHCS, 1/4-20 NC X 1" GR5, FLANGED	3
7	1-861-010034-09	LOCK WASHER, 1/4"	3
8	1-512-010007-05	NUT, HEX 1/4-20 GR2 ZP	6
9	7K442	BRACKET	1
10	6K442	POINTER	1
11	1-861-010034-13	LOCK WASHER, 1/2"	1
12	1-512-010007-09	NUT, 1/2-13 NC REG. HEX	1
13	1-654-010055-02	HHCS, 1/2-13 NC X 1 1/4", GR5	1
14	1-654-010051-05	HHCS, 3/8-16 NC X 1", GR5	1
15	1-861-010034-11	LOCKWASHER, 3/8"	1
16	1-512-010007-07	NUT, 3/8-16 NC	1
17	1-512-010007-11	NUT, 5/8-11 NC REG. HEX	1

Front Seedbox

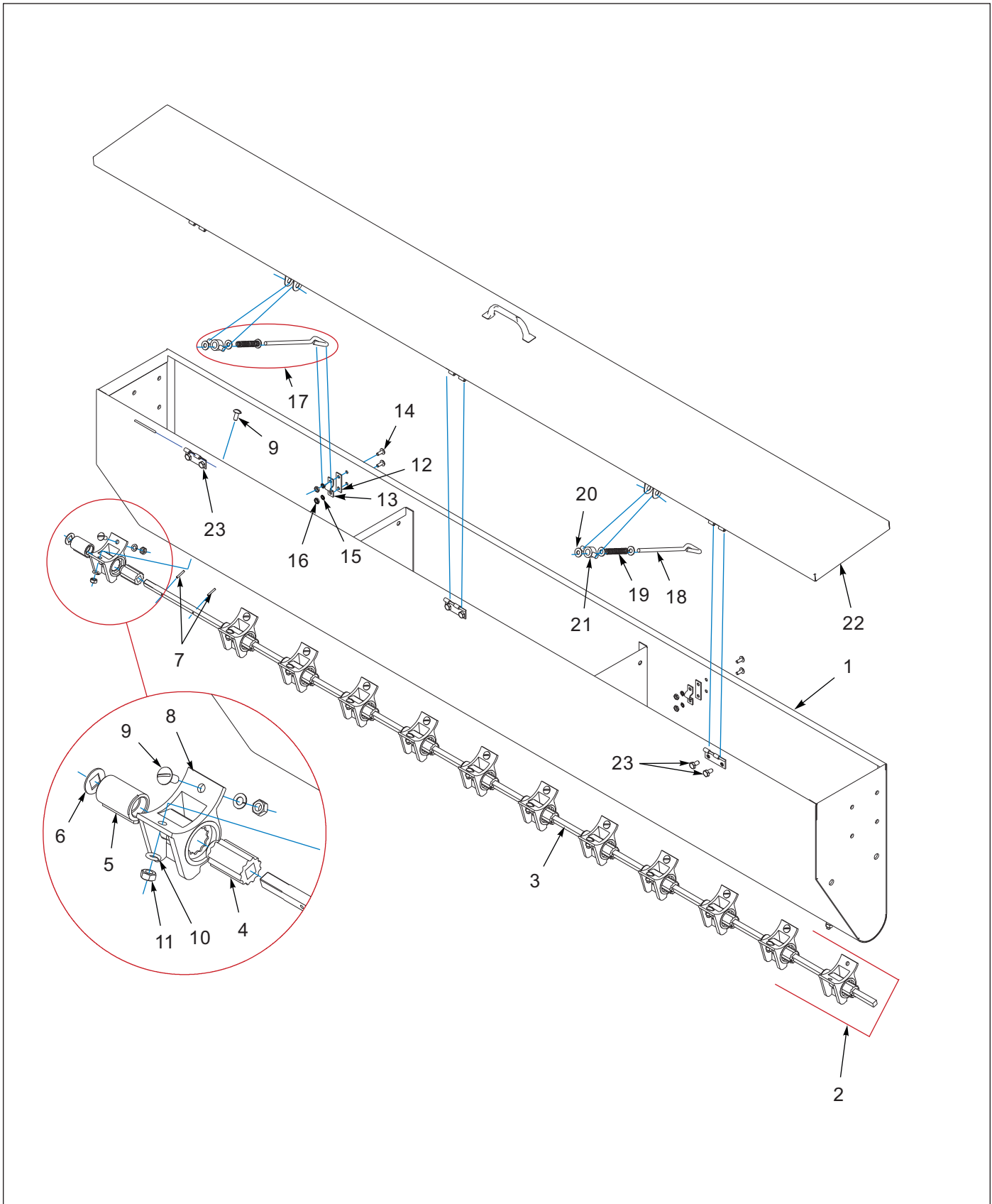

Figure 1-8: Front Seedbox

Front Seedbox

ITEM	PART NUMBER	DESCRIPTION	QTY		
			4'	5'	6'
	7K447	SEEDBOX ASSEMBLY (INCLUDES ITEMS 1-21)	1	--	--
	8K498	SEEDBOX ASSEMBLY (INCLUDES ITEMS 1-21)	--	1	--
	7K415	SEEDBOX ASSEMBLY (INCLUDES ITEMS 1-21)	--	--	1
1	1K024	FABRICATED SEEDBOX (W/O COVER)	1	--	--
1	9J413	FABRICATED SEEDBOX (W/O COVER)	--	1	--
1	2K451	FABRICATED SEEDBOX (W/O COVER)	--	--	1
2	7K446	SEEDMETER SHAFT ASSY (INCLUDES ITEMS 3-8)	1	--	--
2	8K635	SEEDMETER SHAFT ASSY (INCLUDES ITEMS 3-8)	--	1	--
2	7K414	SEEDMETER SHAFT ASSY (INCLUDES ITEMS 3-8)	--	--	1
3	7K448	SEEDMETER SHAFT	1	--	--
3	8K634	SEEDMETER SHAFT	--	1	--
3	7K413	SEEDMETER SHAFT	--	--	1
4	1C242	FEED ROLL	6	7	12
5	1C243	FEED CUT OFF	6	7	12
6	1C245	CUT OFF WASHER	6	7	12
7	1C272	ROLL PIN, 1/8" X 3/4"	12	14	24
8	4C589	SEED CUP	6	7	12
9	108213	SCREW RD HD MACH 1/4-20 X 5/8	12	14	24
10	1-861-010034-09	LOCKWASHER, 1/4" REG.	12	14	24
11	1-512-010007-05	NUT, HEX 1/4-20 GR2 ZP	12	14	24
12	7D937	WEARSTRIP	2	2	2
13	7D938	COVER LOCK CLIP	2	2	2
14	1C213	SCREW, #10-24 NC, 1/2" LONG, RD. HD.	4	4	4
15	1C372	LOCKWASHER, #10 REG.	4	4	4
16	1C386	NUT, #10-24 NC HEX	4	4	4
17	1C199	PIVOT LOCK ASSEMBLY (INCLUDES ITEMS 18-21)	2	2	2
18	1C192	PIVOT LOCK STEM	1	1	1
19	1C212	SPRING	1	1	1
20	3C708	WASHER	3	3	3
21	1C193	PIVOT	1	1	1
22	1K023	COVER	1	--	--
22	9J415	COVER	--	1	--
22	2K453	COVER	--	--	1
23	104877	SCREW, HX CP, 1/4-20UNC X 1/2, GR5	6	6	6

Rear Agitator Seedbox

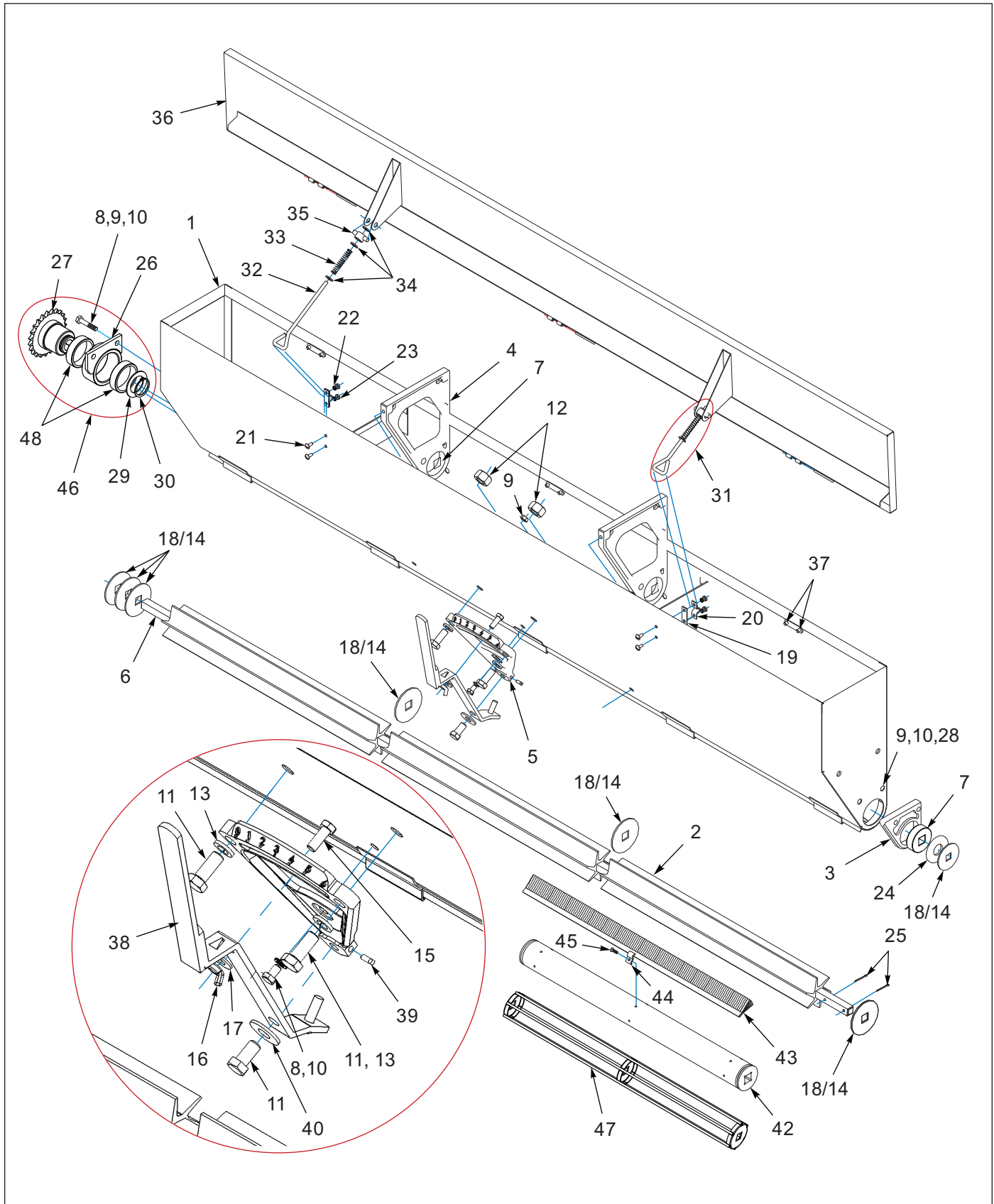

Figure 1-9: Rear Agitator Seedbox

Rear Agitator Seedbox

ITEM	PART NUMBER	DESCRIPTION	QTY		
			4'	5'	6'
	7K450	SEEDBOX ASSEMBLY, 4 FT	1	--	--
	8K497	SEEDBOX ASSEMBLY, 5 FT	--	1	--
	7K410	SEEDBOX ASSEMBLY, 6 FT	--	--	1
1	1K025	SEEDBOX, 4 FT (WITHOUT COVER)	1	--	--
1	9J414	SEEDBOX, 5 FT (WITHOUT COVER)	--	1	--
1	2K452	SEEDBOX, 6 FT (WITHOUT COVER)	--	--	1
2	6K603	BLADE AGITATOR, (22 1/2" - SSP4)	2	--	--
2	6K604	BLADE AGITATOR, (28 1/2" - SSP5)	--	2	--
2	7K656	BLADE AGITATOR, (22 15/16" - SSP6)	--	--	3
3	9D793	BOX END BEARING	1	--	--
4	1C339	INTERMEDIATE AGITATOR BEARING	2	1	1
5	2C662	SHIFTER PLATE	1	1	1
6	7K449	AGITATOR SHAFT	1	--	--
6	8K628	AGITATOR SHAFT	--	1	--
6	7K407	AGITATOR SHAFT	--	--	1
7	2C808	BUSHING 6 FT	2	2	3
8	1-654-010049-03	HHCS, 5/16-18 NC X 3/4", GR5	5	5	11
9	1-512-010007-06	NUT, 5/16-18 NC REG. HEX	4	8	5
10	1-861-010034-10	LOCKWASHER, 5/16" REG.	8	8	13
11	1-654-010055-02	HHCS, 1/2-13 NC X 1 1/4", GR5	2	2	2
12	1-512-010007-09	NUT, 1/2-13 NC REG. HEX	2	2	2
13	1-861-010034-13	LOCKWASHER, 1/2" REG	2	2	2
14	8J564	WASHER .0747 X 2 3/4 OD W/21/32 SQ. HOLE, THIN	2	0	3
15	1C606	BOLT, 3/8-16 NC SQ. HD. X 1"	1	1	1
16	1C217	WINGNUT, 3/8-16 NC	1	1	1
17	1C182	WASHER, 3/8 STD.	1	1	1
18	2C809	WASHER, SQ BORE 12GA	4	9	3
19	7D937	WEAR STRIP	2	2	2
20	7D938	COVER LOCK CLIP	2	2	2
21	1C213	SCREW, #10-24 NC RD. HD. X 1/2"	4	4	4
22	1C372	LOCKWASHER, #10 REG.	4	4	4
23	1C386	NUT, #10-24 NC REG. HEX	4	4	4
24	1-861-010032-22	WASHER, SAE 7/8"	2	2	2
25	1C205	COTTER PIN, 5/32 X 1 1/2"	2	2	2
26	7K408	BEARING CARRIER (INCLUDES ITEM 48)	1	1	1
27	7K409	23 TOOTH SPROCKET AND HUB	1	1	1
28	7D077	CAPSCREW, 5/16-18 NC X 1 1/4", GR5	2	2	2
29	7C086	MACHINERY BUSHING, 1 3/8"	1	1	1
30	7K017	RETAINING RING	1	1	1
31	1C199	PIVOT LOCK ASSEMBLY (INCLUDES ITEMS 32-35)	2	2	2
32	1C192	PIVOT LOCK STEM	1	1	1
33	1C212	SPRING	1	1	1
34	3C708	WASHER	3	3	3
35	1C193	PIVOT	1	1	1
36	1K023	COVER	1	--	--
36	9J415	COVER	--	1	--
36	2K453	COVER	--	--	1

Rear Agitator Seedbox

ITEM	PART NUMBER	DESCRIPTION	QTY		
			4'	5'	6'
37	104877	CAPSCREW, 1/4-20 NC X 1/2" LONG, HEX HD., GR5	6	6	6
38	9J422	SHIFT HANDLE	1	1	1
39	2C170	SET SCREW, 1/4-20 NC X 1/4" SQ. HD.	1	1	1
40	1-861-010032-15	FLAT WASHER, 1/2" REG.	1	1	1
41	3C995	BRUSH AGITATOR ASSY (OPTIONAL, INCLUDES ITEMS 46-49 W/ 14 AND 18)	2	--	3
41	5C882	BRUSH AGITATOR ASSY (OPTIONAL, INCLUDES ITEMS 46-49 W/ 14 AND18)	--	2	--
42	3C996	AGITATOR PIPE	2	--	3
42	5C881	AGITATOR PIPE	--	2	--
43	3C997	BRUSH STRIP, 22 1/4" (5 FOR EACH 3C995)	10	--	15
43	4C003	BRUSH STRIP, 16 1/2" (5 FOR EACH 5C882)	--	10	--
43	5C880	BRUSH STRIP, 11 1/2" (5 FOR EACH 5C882)	--	10	--
44	3C956	BRUSH CLIP	30	50	45
45	3C998	SCREW (PHILLIPS PAN HEAD, SELF-TAPPING, #8-32 NC X 1/2)	30	50	45
46	7K677	AGITATOR SPROCKET ASSY (INCLUDES ITEMS 26,27,29,30 AND 48)	1	1	1
47	2C815	AGITATOR CAGE ASSEMBLY (22 1/2" - SSP4)	2	--	--
47	5C195	AGITATOR CAGE ASSEMBLY (28 1/2" - SSP5)	--	2	--
47	9D794	AGITATOR CAGE ASSEMBLY (22 15/16" - SSP6)	--	--	3
48	2C582	BUSHING	2	2	2

Coil Tine Wheel Track Remover 4' and 5'

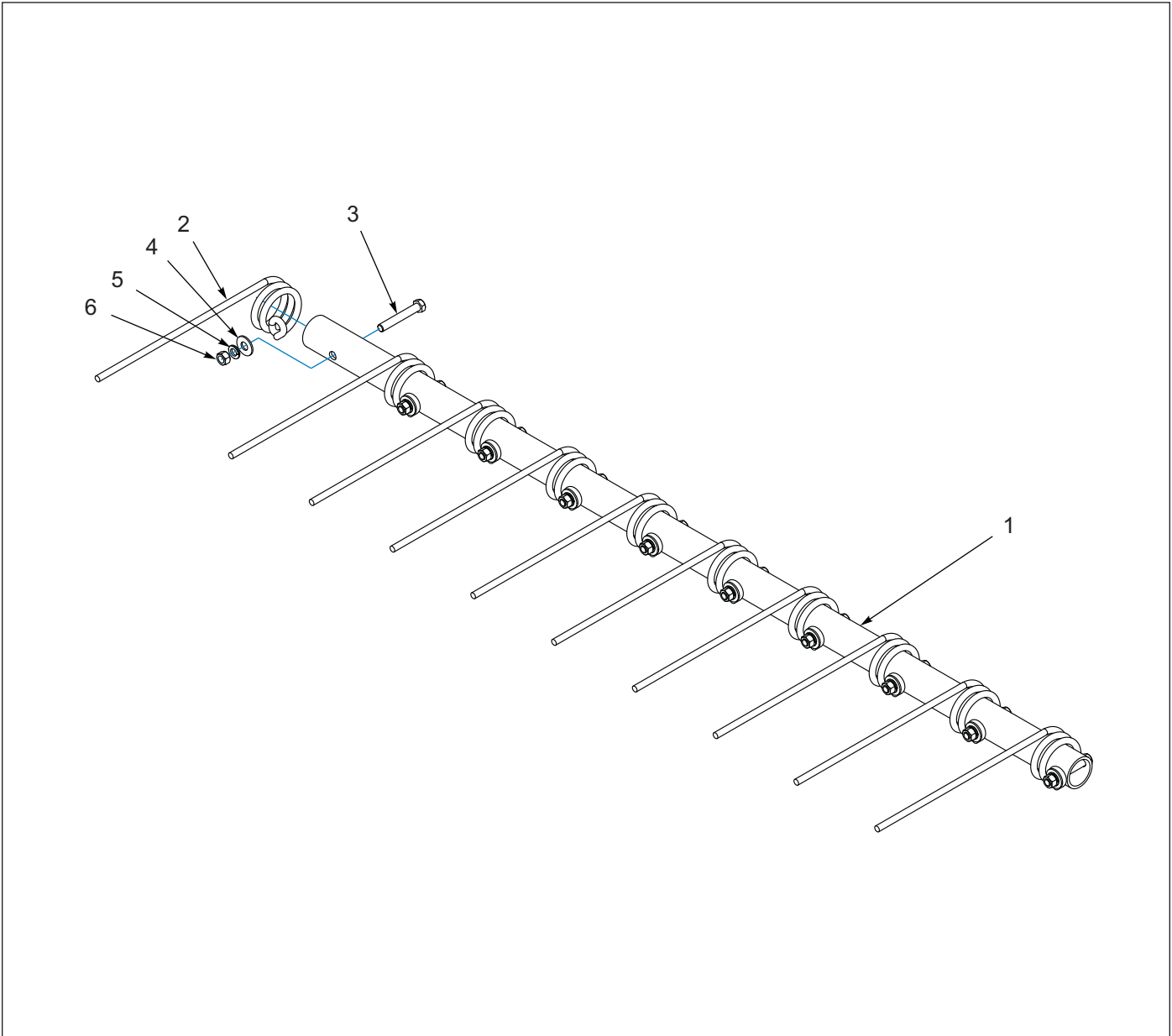

Figure 1-10: Coil Tine Wheel Track Remover 4' and 5'

Coil Tine Wheel Track Remover 4' and 5'

ITEM	PART NUMBER	DESCRIPTION	QTY	
			4'	5'
	6K083	PIPE & TINE ASSY - 4' (SHOWN)	1	--
	8K600	5' PIPE & TINE ASSY	--	1
1	6K172	PIPE, 4 FT	1	--
1	8K606	PIPE, 5 FT	--	1
2	5J603	COIL TINE	10	13
3	5D667	CAPSCREW, 3/8-16 NC X 2 1/2", GR5	10	13
4	1C182	FLAT WASHER, 3/8"	10	13
5	1-861-010034-11	LOCKWASHER, 3/8"	10	13
6	1-512-010007-07	NUT, 3/8-16 NC	10	13

Coil Tine Wheel Track Remover 6'

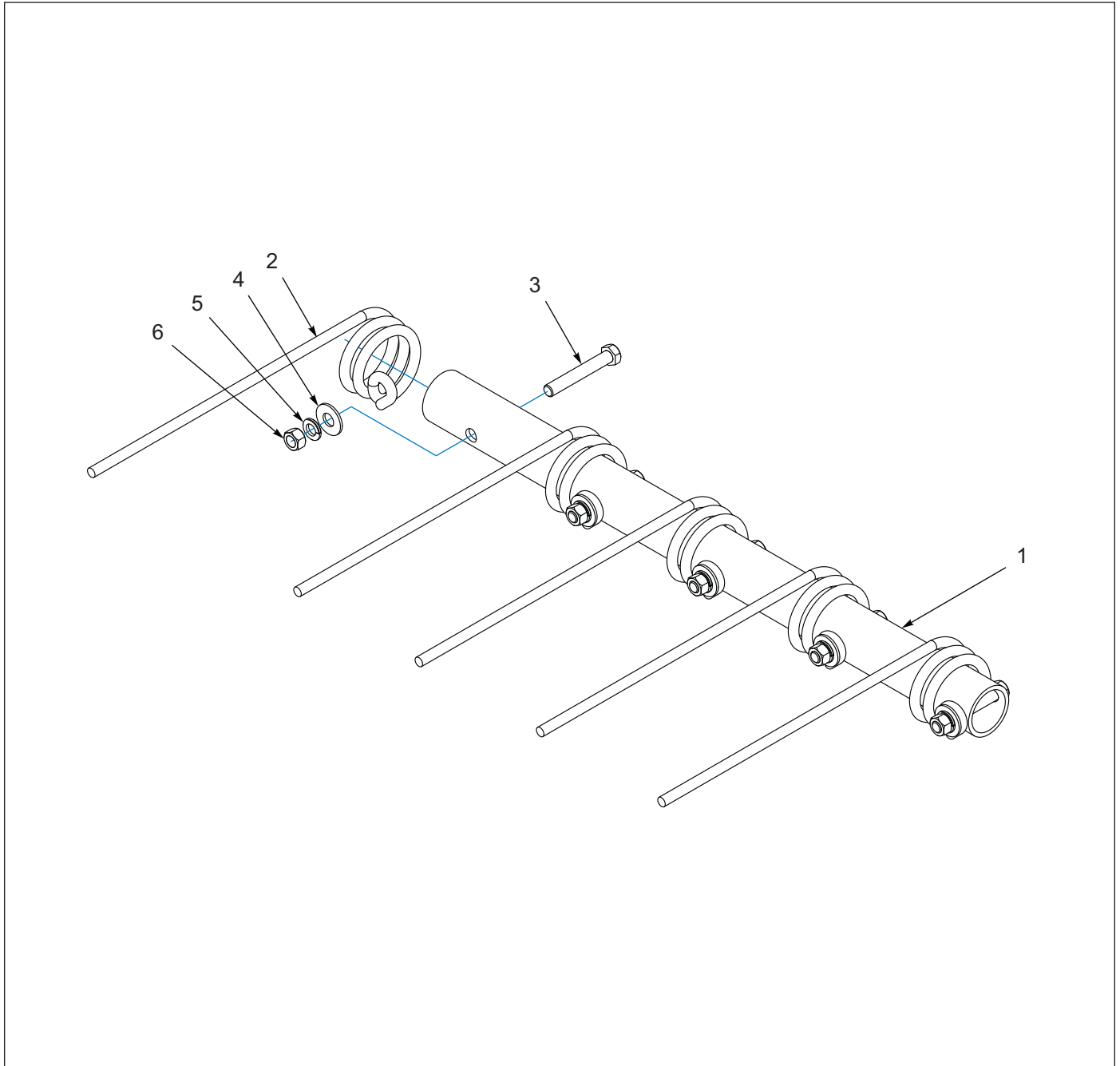

Figure 1-11: Coil Tine Wheel Track Remover 6'

Coil Tine Wheel Track Remover 6'

ITEM	PART NUMBER	DESCRIPTION	QTY
	6K027	6' PIPE & TINE ASSY	2
1	6K041	PIPE	1
2	5J603	COIL TINE	5
3	1-654-010051-11	SCREW, HX CP 3/8-16 X 2-1/2, G5, ZP	5
4	1-861-010032-11	WASHER, FLAT 3/8 W ZP/CD	5
5	1-861-010034-11	WASHER, LKG HLCL SPR, 3/8	5
6	1-512-010007-07	NUT, HEX 3/8-16, ZP	5

Electric Acre Meter Assembly

Note: If you replace a meter supplied prior to 5/15/2012 with a new Loup meter you will need to change out the protective box items 1 and 3 due to the new meter being physically larger.

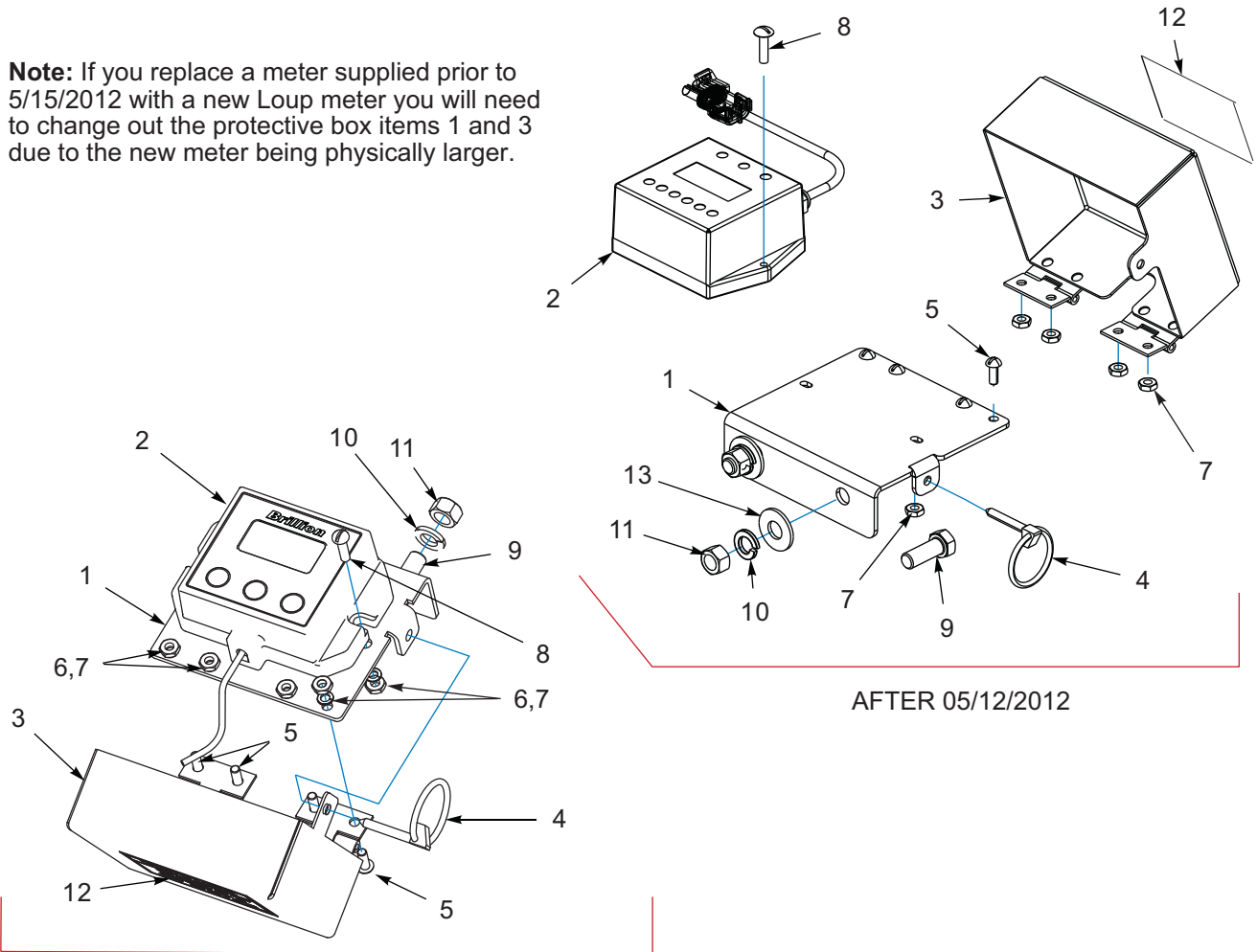

AFTER 05/12/2012

PRIOR TO 05/12/2012

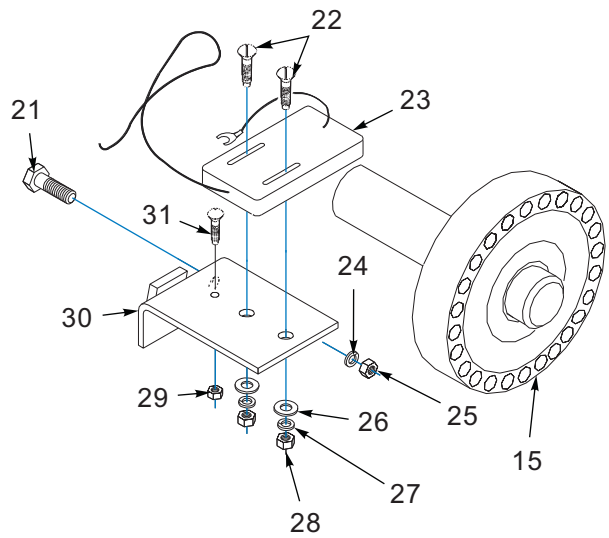
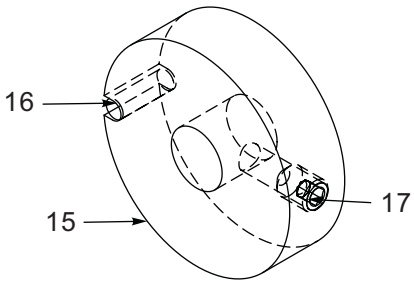

Figure 1-12: Electric Acre Meter Assembly

Electric Acre Meter Assembly

ITEM	PART NUMBER	DESCRIPTION	QTY
	5K310	ACRE METER ASSEMBLY (INCLUDES ITEMS 1-13)	1
1	170943	MOUNT-ACRE METER (05/15/2012 AND AFTER)	1
1	9K739	BRACKET, ACRE METER (05/14/2012 AND PRIOR)	1
2	170948	CONSOLE, ELECTRONIC ACRE (05/15/2012 AND AFTER)	1
2	153861	CONSOLE, ELECTRONIC ACRE (05/14/2012 AND PRIOR)	1
3	170946	COVER-ACRE METER, WELDMENT (05/15/2012 AND AFTER)	1
3	9K741	COVER, ACRE METER WLD (05/14/2012 AND PRIOR)	1
4	5D129	KLIK-PIN	1
5	1C213	STOVE BOLT #10-24 X 1/2 RD HD, ZP	4
6	1C372	WASHER, LKG, HLCL SPR NO 10 (05/14/2012 AND PRIOR)	6
7	1-512-010007-03	NUT (HEX #10-24, ZP)	6
8	1-656-010003051	ROUND HEAD MACHINE SCREW (#10-24 X 3/4, ZP)	2
9	1-654-010051-05	CAPSCREW, (3/8-16 X 1, GR5, ZP)	2
10	1-861-010034-11	LOCKWASHER, (3/8, ZP)	2
11	1-512-010007-07	NUT, (HEX 3/8-16, ZP)	2
12	9K740	DECAL, ACRE METER	1
13	1-861-010032-11	WASHER, FLAT 3/8 W, ZP/CD (05/15/2012 AND AFTER)	2
14	5K277	MAGNET WHEEL ASSEMBLY (INCLUDES ITEMS 15 -17)	1
15	7K962	MAGNET WHEEL	1
16	7K963	MAGNET	1
17	122709	SCREW, SET, HXSKTCPPT 3/8-16 X 1/2	1
18	5K287	CABLE TIE MOUNTING BASE (NOT SHOWN)	6
19	5K288	CABLE TIE (NOT SHOWN)	6
20	165622	HARNESS-MAKEUP, ACRE METER (NOT SHOWN)	1
21	1-654-010049-05	HHCS 5/16-18 X 1 GR5, ZP (EXISTING HARDWARE)	1
22	5K262	ROUND HEAD MACHINE SCREW (#8 - 32 X 1.25)	2
23	5K278	PICK-UP SWITCH	1
24	1-861-010034-10	WASHER, LOCK 5/16, ZP	2
25	1-512-010007-06	NUT HEX 5/16-18, ZP	2
26	5K263	WASHER, FL #8, ZP/CD	2
27	5K264	#8 LOCK WASHER, ZP	2
28	5K265	NUT, HEX #8 - 32, ZP	2
29	5K266	NUT HEX HD #6-32	1
30	6K447	BRACKET	1
31	2D045	SCREW RD HD MACH 6-32NC X 1/2	1

CAT2 Quick Coupler Hitch Adaptor - Optional

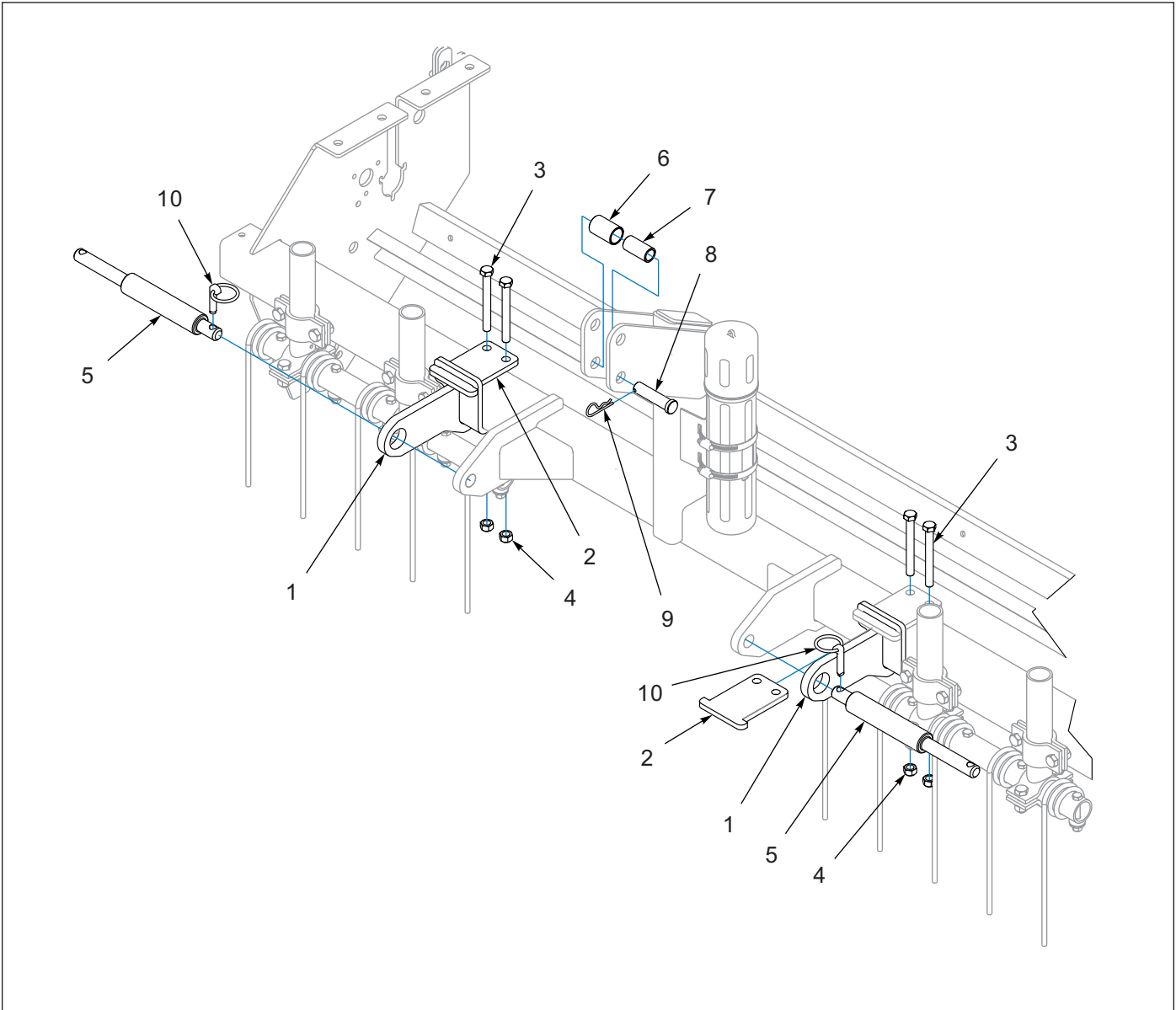

Figure 1-13: CAT2 Quick Coupler Hitch Adaptor Kit - Optional

CAT2 Quick Coupler Hitch Adaptor Kit - Optional

ITEM	PART NUMBER	DESCRIPTION	QTY
	210928	KIT,CAT2QH,LSP/SSP4,5,6	1
1	210925	HITCH LUG WLDMT	2
2	210927	PLATE,CLAMP	2
3	1-654-010055-14	SCREW,HX CP,1/2-13UNCX4-1/2GR	4
4	1-512-010005-09	NUT,HEX,SLFLKG, 1/2-13 GRB	4
5	210926	PIN, LOWER, 3-POINT	2
6	5D157	SLEEVE (1-1/4 OD x 1-15/16 LG)	1
7	7K229	SLEEVE - 1 OD X 2 LG (EXISTING HARDWARE)	1
8	7D642	CLEVIS PIN (3/4 X 3) (EXISTING HARDWARE)	1
9	6J448	HAIRPIN COTTER 1/8 (EXISTING HARDWARE)	1
10	7631	QUICK PIN (EXISTING HARDWARE)	2

Lift Sling Kits

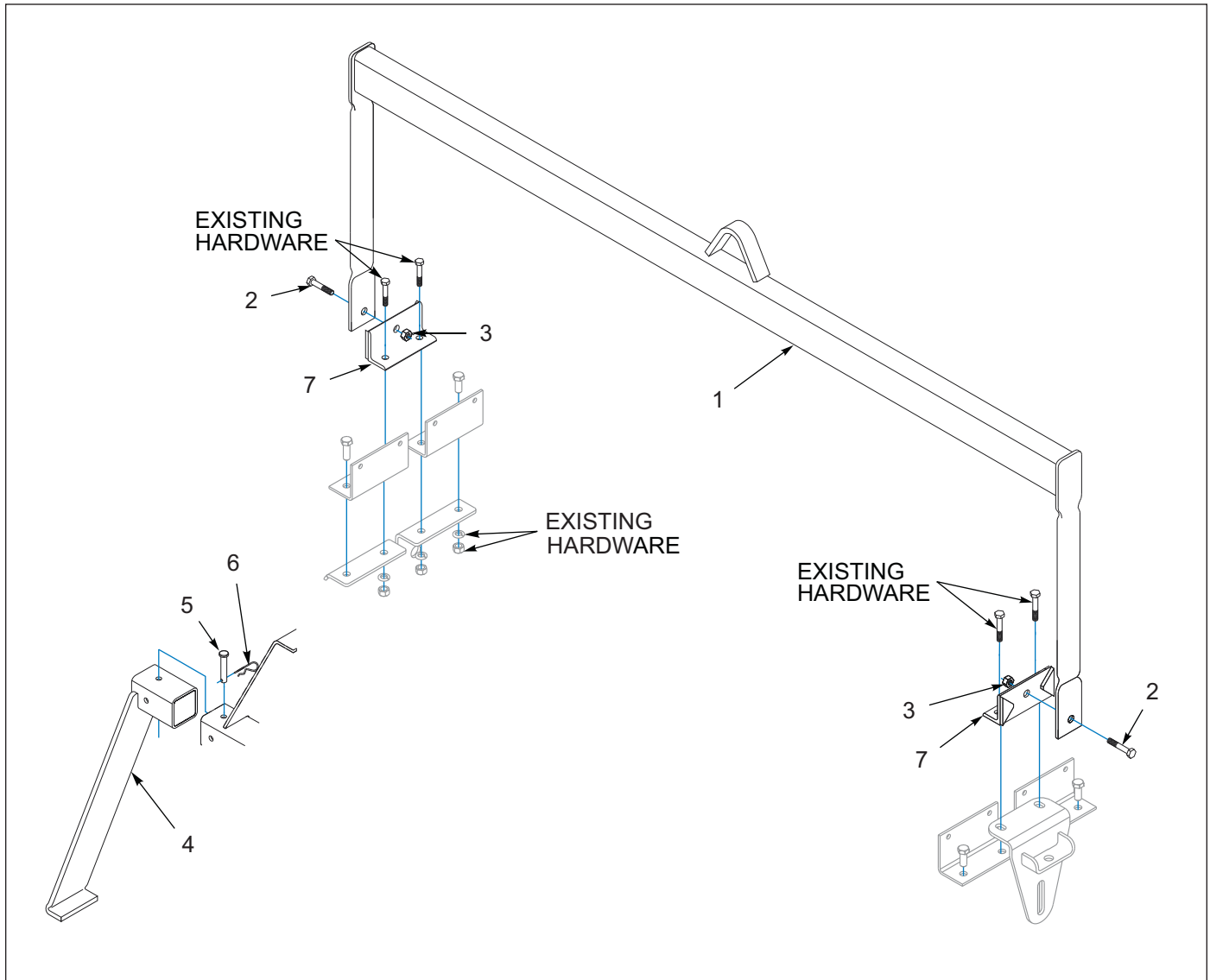

Figure 1-14: Lift Sling Kits

Lift Sling Kits

ITEM	PART NUMBER	DESCRIPTION	QTY		
			4'	5'	6'
	6K081	LIFT SLING KIT, 4FT	1	--	--
	8K636	LIFT SLING KIT, 5FT	--	1	--
	6K060	LIFT SLING KIT, 6FT	--	--	1
1	6K080	LIFT SLING, 4FT	1	--	--
1	8K637	LIFT SLING, 5FT	--	1	--
1	6K059	LIFT SLING, 6FT	--	--	1
2	1-654-010059-03	SCREW, 5/8-11UNC X 1-1/2 HXCP, G5	2	2	2
3	1-512-010005-13	NUT, HEX SLFLKG GRB 5/8-11	2	2	2
4	6K207	STABILIZER	1	1	1
5	1K936	CLEVIS PIN	1	1	1
6	4C856	HAIR PIN COTTER	1	1	1
7	6K051	MOUNTING BRACKET	2	2	2

Decals

ITEM	PART NUMBER	DESCRIPTION	QTY
1	4K401	DECAL, SURE STAND	1
2	8J310	DECAL, CAUTION	1
3	9J302	DECAL, CAUTION	1
4	7K452	DECAL - SS4	1
4	8K599	DECAL - SS5	1
4	7K428	DECAL - SS6	1
5	528934	REFLECTOR - YELLOW	2
6	528933	REFLECTOR - RED	2
7	528938	STRIPE, ORANGE	2
8	9J301	DECAL, PARKING PIN	1
9	2K123	DECAL, WARNING	2
10	7K434	SEED CHART-SSP4/5/6 REAR BOX	1
11	7K454	SEED CHART-SSP4/SSP5 FRONT BOX (SSP4 AND 5)	1
11	7K433	SEED CHART-SS6 FRONT BOX (SSP6 ONLY)	1
12	4K036	DECAL-BRILLION (2 3/4 X 20)	1

Decal Locations

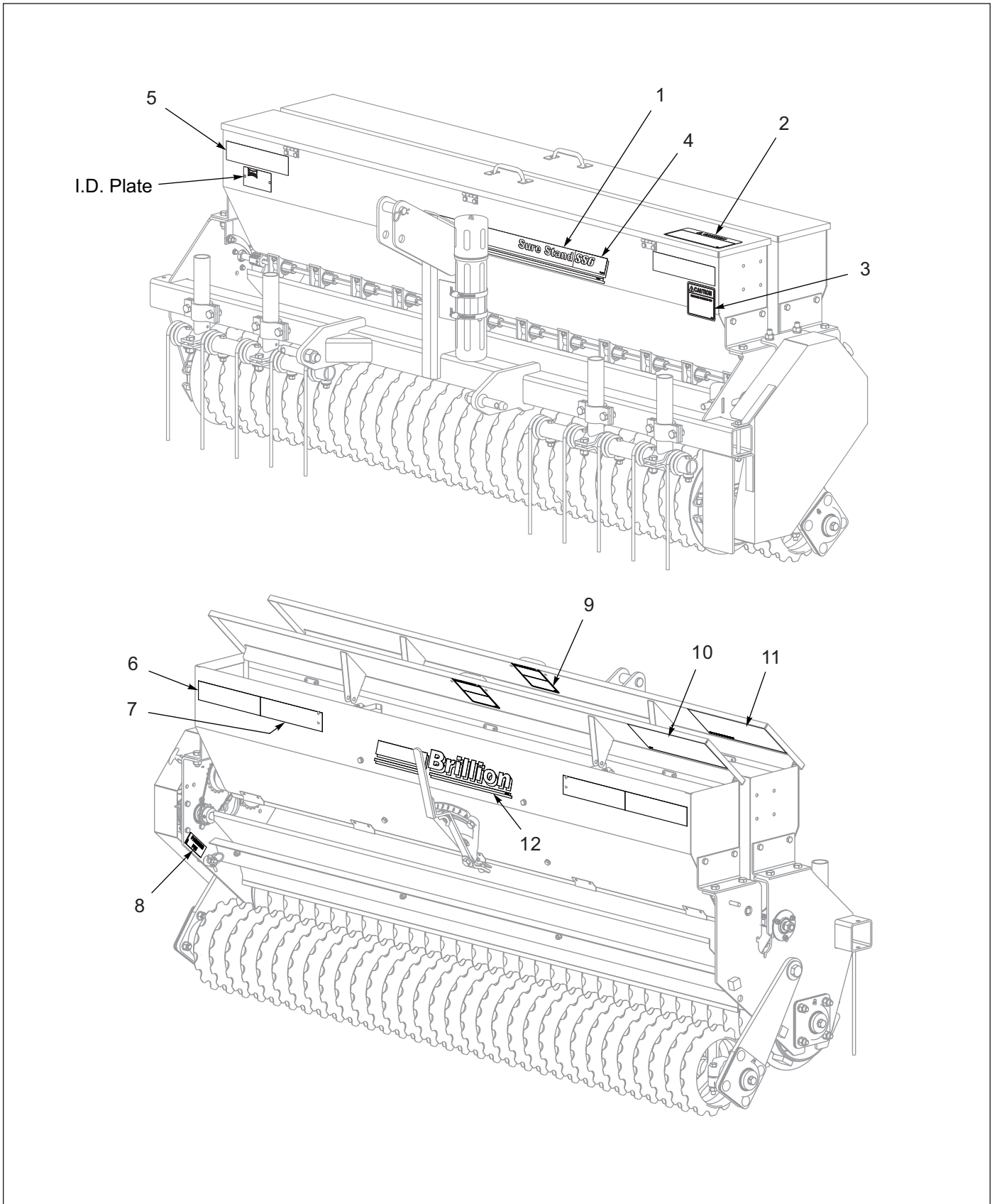

Figure 1-16: Decal Locations

Glossary

For clarity this glossary of industry standard abbreviations and their definitions are provided. For additional information, see “**Instructions for Ordering Parts**” on page 1-1 of this manual.

A

ASM Assembly

B

BATT Battery
BHSC Button Head Socket Cap
BLK Black

C

CB Carriage Bolt
CONN Connector
CRG Carriage
CTSK Countersunk
CTWT Counterweight
CVR Cover
CYD Cylinder

D

DBL Double
DIA Diameter

E

ENCLSD Enclosed

F

FHCS Flanged Head Cap Screw
FHHCS Flanged Hex Head Cap Screw
FL OR FLG Flange
FLT Flat

G

GA Gauge

H

HHCS Hex Head Cap Screw
HCS High Carbon Steel
HD Head
HLCL Helical
HCSKT Hex Socket
HSFC Hex Socket Flat Countersunk
HYD Hydraulic

I

ID Inside Diameter

L

LH Lefthand
LKG OR LOCK Locking
LWR Lower

M

MANF Manifold
MNT Mount

N

NRW Narrow
----- Not Serviced Separately

O

OD Outside Diameter
OHG Overhead Guard
ORFS OR ORS O-Ring Seal
ORP OR ORB O-Ring Boss

P

P-STEER Power Steering
PTFE Polytetrafluoroethylene (Teflon)

R		SQ	Square
RH	Righthand	SRTD	Serrated
RND	Round	SSCR	Setscrew
		SST	Stainless Steel
		STD	Standard
S		U	
SER	Series	UPR	Upper
SHCS	Socket Head Cap Screw	W	
SHLD	Shield	WHL	Wheel
SKT	Socket	WLD OR WLDMT	Weldment
SLFLKG	Selflocking		
SOC	Socket		
SPDT	Single Pole Double Throw		
SPR	Spring		

Numerics

104665	1-7	1-654-010061-05	1-7
104877	1-13, 1-16	1-656-010003051	1-21
105-0093	1-3, 1-5	165622	1-21
1-065-010011	1-7	170943	1-21
107-0814	1-3, 1-5	170946	1-21
107-0975	1-11	170948	1-21
108213	1-13	1-861-010032-11	1-3, 1-5, 1-19, 1-21
108295	1-3, 1-5	1-861-010032-15	1-10, 1-16
1-116-010019	1-3, 1-5	1-861-010032-19	1-10
117721	1-10	1-861-010032-20	1-10
119083	1-7, 1-10	1-861-010032-21	1-7, 1-10
122709	1-21	1-861-010032-22	1-15
1-512-010005-05	1-3, 1-5	1-861-010034-09	1-11, 1-13
1-512-010005-13	1-10, 1-23	1-861-010034-10	1-3, 1-5, 1-10, 1-15, 1-21
1-512-010007-03	1-21	1-861-010034-11	1-11, 1-18, 1-19, 1-21
1-512-010007-06	1-3, 1-5, 1-10, 1-15, 1-21	1-861-010034-13	1-3, 1-5, 1-7, 1-9, 1-11, 1-15
1-512-010007-07	1-11, 1-18, 1-19, 1-21	1-861-010034-15	1-7, 1-9
1-512-010007-09	1-3, 1-5, 1-7, 1-9, 1-11, 1-15	1-861-010034-17	1-7
1-512-010007-11	1-7, 1-9, 1-11	1C179	1-7
1-512-010007-12	1-7	1C182	1-15, 1-18
1-512-010007-15	1-11, 1-13	1C192	1-13, 1-15
153861	1-21	1C193	1-13, 1-15
1-557-010327	1-3, 1-5	1C199	1-13, 1-15
1-647-010004217	1-7, 1-9	1C205	1-15
1-654-010049-03	1-3, 1-5, 1-15	1C212	1-13, 1-15
1-654-010049-05	1-3, 1-5, 1-10, 1-21	1C213	1-13, 1-15, 1-21
1-654-010051-05	1-11, 1-21	1C217	1-15
1-654-010051-11	1-19	1C242	1-13
1-654-010055-02	1-3, 1-5, 1-11, 1-15	1C243	1-13
1-654-010055-03	1-3, 1-5, 1-7	1C245	1-13
1-654-010055-04	1-3, 1-5, 1-10	1C272	1-13
1-654-010059-03	1-23	1C314	1-7
1-654-010059-09	1-10	1C339	1-15
		1C372	1-13, 1-15, 1-21
		1C386	1-13, 1-15

1C606	1-15	4K036	1-25
1D598	1-10	4K401	1-25
1K023	1-13	51365-4	1-3, 1-5
1K024	1-13	528933	1-25
1K200	1-10	528934	1-25
1K936	1-23	528938	1-25
2C112	1-7	5C195	1-16
2C170	1-16	5C284	1-7
2C524	1-7	5C460	1-10
2C582	1-16	5C516	1-10
2C662	1-15	5C880	1-16
2C801	1-7	5C881	1-16
2C808	1-15	5C882	1-16
2C809	1-15	5C907	1-10
2C815	1-16	5D129	1-21
2C830	1-16	5D667	1-18
2D045	1-21	5J603	1-18, 1-19
2K123	1-25	5K262	1-21
2K451	1-13	5K263	1-21
2K452	1-15	5K264	1-21
2K453	1-13	5K265	1-21
2K475	1-7	5K266	1-21
2K503	1-10	5K277	1-21
2K656	1-3, 1-5	5K278	1-21
3C708	1-13, 1-15	5K287	1-21
3C955	1-7	5K288	1-21
3C956	1-16	5K310	1-21
3C995	1-16	5K989	1-11
3C996	1-16	6C400	1-3, 1-5
3C997	1-16	6D305	1-10
3C998	1-16	6D476	1-10
4C003	1-16	6J195	1-10
4C140	1-7	6J448	1-3, 1-5
4C144	1-7	6K010	1-3, 1-5
4C145	1-7	6K012	1-7
4C589	1-13	6K014	1-7
4C689	1-7	6K015	1-7
4C856	1-23	6K016	1-7

6K017	1-7	7D077	1-15
6K026	1-3, 1-5	7D642	1-3, 1-5
6K027	1-5, 1-19	7D937	1-13, 1-15
6K032	1-3, 1-5	7D938	1-13, 1-15
6K041	1-19	7K017	1-15
6K051	1-23	7K113	1-10
6K056	1-3, 1-5	7K114	1-10
6K057	1-3, 1-5	7K118	1-10
6K060	1-23	7K229	1-3, 1-5
6K066	1-7	7K237	1-11
6K070	1-7	7K348	1-5
6K071	1-7	7K408	1-15
6K072	1-7	7K409	1-15
6K073	1-7	7K410	1-15
6K081	1-23	7K413	1-13
6K083	1-3, 1-18	7K414	1-13
6K172	1-18	7K415	1-13
6K207	1-23	7K418	1-3, 1-5, 1-10
6K378	1-10	7K419	1-3, 1-5
6K391	1-11	7K420	1-3, 1-5, 1-10
6K442	1-11	7K423	1-10
6K443	1-11	7K428	1-25
6K447	1-21	7K429	1-10
6K604	1-15	7K433	1-25
6K730	1-10	7K434	1-25
6K749	1-10	7K436	1-10
6K812	1-7	7K438	1-10
6K815	1-10	7K439	1-10
6K816	1-10	7K442	1-3, 1-5, 1-11
6K817	1-10	7K446	1-13
6K820	1-10	7K447	1-13
6K842	1-10	7K448	1-13
6K856	1-10	7K451	1-3
6K861	1-5	7K452	1-25
6K862	1-3	7K454	1-25
6K868	1-10	7K590	1-3, 1-5, 1-10
7C086	1-15	7K656	1-15
7C783	1-7	7K677	1-16

7K962	1-21
7K963	1-21
8C381	1-7, 1-9
8C892	1-10
8J310	1-25
8J564	1-15
8K488	1-7
8K489	1-7
8K491	1-7
8K492	1-7
8K495	1-3
8K496	1-3
8K497	1-15
8K498	1-13
8K599	1-25
8K600	1-3, 1-18
8K606	1-18
8K634	1-13
8K635	1-13
8K636	1-23
8K637	1-23
9D772	1-7, 1-9
9D793	1-15
9D794	1-16
9D816	1-11
9J301	1-10, 1-25
9J302	1-25
9J338	1-7
9J379	1-10
9J399	1-7
9J413	1-13
9J414	1-15
9J415	1-13, 1-15
9J457	1-3, 1-5
9J559	1-7
9K739	1-21
9K740	1-21
9K741	1-21

Document Control Revision Log:

Date	Form #	Improvement(s): Description and Comments
04/16/08	402rev4-16-08	Latest Release
07/06/11	402rev0811	Improved Pictures and Drawings
03/13/13	402rev0313	Added New Acre Meter Data
02/2021	7K554-0221	ECN 46903 - Added CAT2 Quick Coupler Hitch Adaptor Kit Option



Intertek

Equipment from Landoll Company, LLC is built to exacting standards ensured by ISO 9001 registration at all Landoll manufacturing facilities.

Sure Stand Seeder Models SSP4, SSP5 and SSP6 Parts Manual

Re-Order Part Number 7K554

LANDOLL COMPANY, LLC

1900 North Street

Marysville, Kansas 66508

(785) 562-5381

800-428-5655 ~ **WWW.LANDOLL.COM**



Copyright 2021. Landoll Company, LLC

“All rights reserved, including the right to reproduce this material or portions thereof in any form.”

