

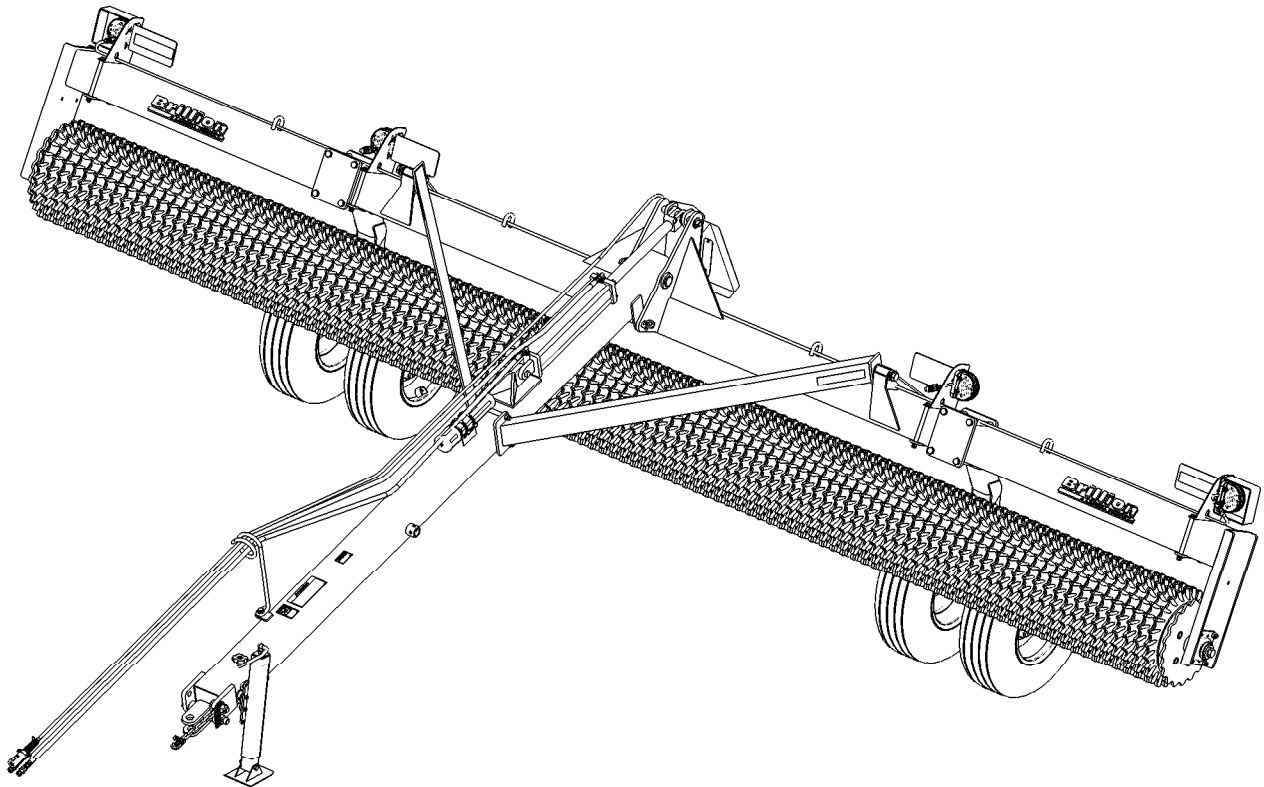

Floating Ring Pulverizer PFT 20' and 22' Models Parts Manual



LANDOLL CORPORATION

1900 North Street
Marysville, Kansas 66508
(785) 562-5381

800-428-5655 ~ WWW.LANDOLL.COM

Table of Contents

1 Illustrated Parts List

Instructions for Ordering Parts	1-1
ID Plate	1-1
Frame	1-2
Wheel Arms	1-4
Hub and Spindle	1-5
Wheel Assembly	1-6
Drawbar	1-8
Floating Ring Roller Assembly	1-10
Bridge Hitch	1-12
Bridge Hitch Braces	1-14
Hydraulics	1-16
Bridge Hitch Hydraulics	1-18
Electrical Layout	1-20
Hydraulic Cylinder, 4 x 20	1-22
Decals	1-24

2 Numerical Index

3 Glossary

Illustrated Parts List

Instructions for Ordering Parts

**** Repair parts must be ordered through an authorized dealer ****

DEALER INSTRUCTIONS FOR ORDERING PARTS FROM LANDOLL PARTS DISTRIBUTION CENTER

PHONE #: 800-423-4320 OR 785-562-5381

FAX #: 888-527-3909

ORDER ONLINE: Dealer.landoll.com

IDENTIFICATION PLATE

See Figure 1-1. for the Identification Plate, which lists the model and serial number of the equipment. It is located on the rear of the frame right of center of the Floating Ring Pulverizer.

SERIAL NUMBER NOMENCLATURE

The serial number for the Floating Ring Pulverizer is located on the identification plate. The following information will help decode the Landoll serial number.

PXB1700101 = XXMYSSSSS

XX	= Model Series (i.e. "PX" for all Pulverizers)
M	= Month of Manufacture (ex. "B" means February. The letter I is not used.)
YY	= Year Manufactured (ex. "17" means 2017)
SSSS	= Sequential number used to track warranty and service information.

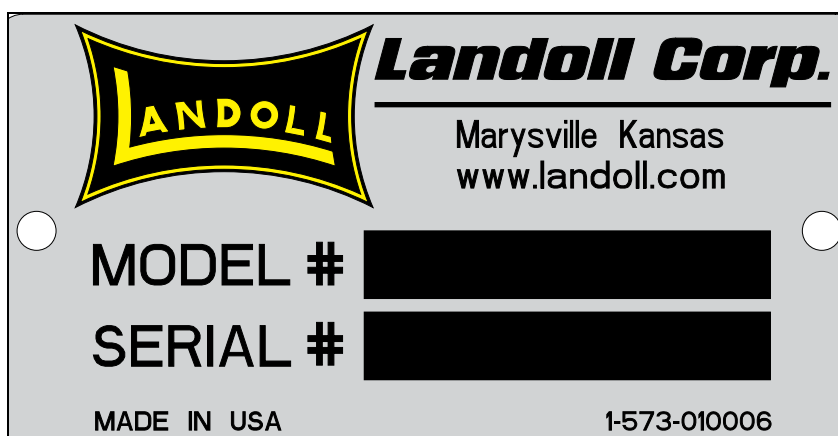

Figure 1-1: ID Plate

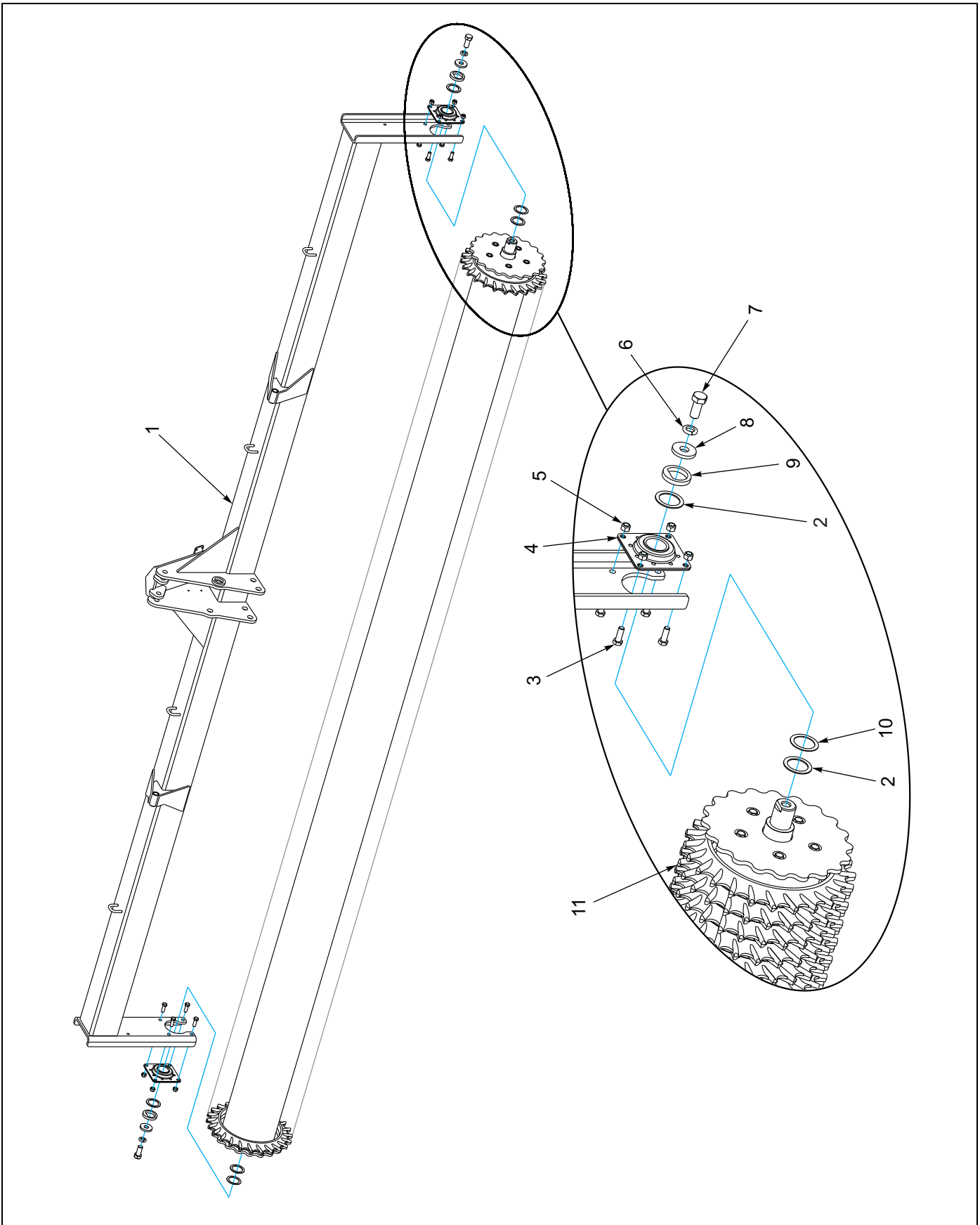

Figure 1-2: Frame

Frame

ITEM	PART NUMBER	DESCRIPTION	QTY.
1	188024	FRAME, WLD, PFT20	1
1	188037	FRAME, WLD, PFT22	1
2	185170	WASHER, SHIM 11 GA 2.43 ID	4
3	1-654-010059-04	SCREW, HEX CAP 5/8-11X1-3/4 G5	8
4	185167	FLANGE BEARING 61mm BORE	2
5	1-512-010005-13	NUT, HEX SLFLKG GRB 5/8-11	8
6	1-861-010034-21	WASHER, LKG HEL SPRG 1IN	2
7	137943	SCREW, HEX CAP 1-8UNCX2-1/4 GR5	2
8	154185	WASHER, 3/8 THICK 1" ID	2
9	185166	WASHER, FLAT TOP	2
10	185171	WASHER, SHIM 14 GA 2.43 ID	2
11	185969	ROLLER ASM, FLOATING RING, 20' (SEE FIGURE 1-7)	1
11	188036	ROLLER ASM, FLOATING RING, 22' (SEE FIGURE 1-7)	1

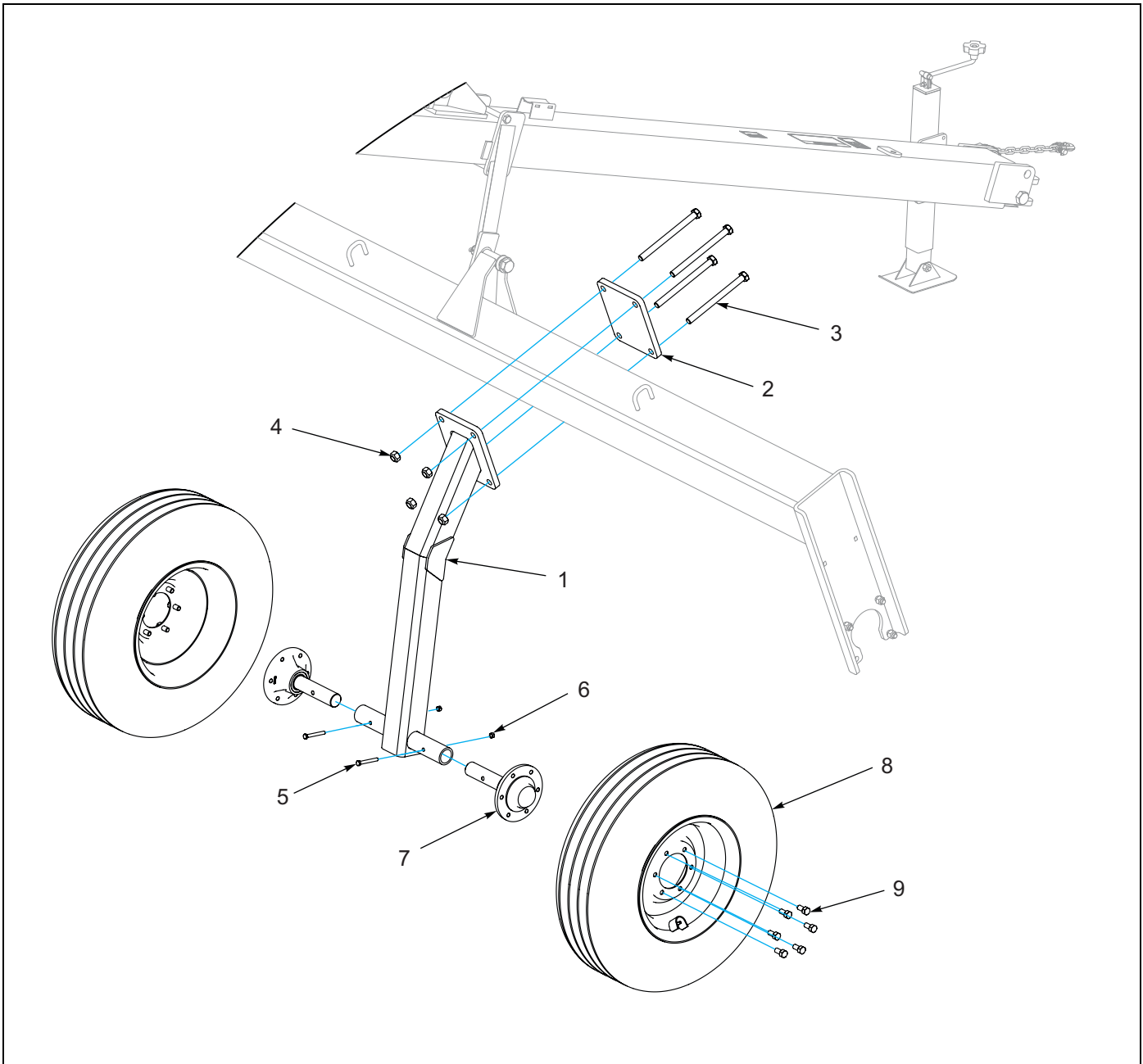

Figure 1-3: Wheel Arms

Wheel Arms

ITEM	PART NUMBER	DESCRIPTION	QTY.
1	188010	WHEEL ARM, PFT	2
2	5K195	PLATE	2
3	104436	SCREW,HX CP, 3/4-10UNCX9-1/2 GR5	8
4	1-512-010005-15	NUT, HEX SLFLKG GRB 3/4-10	8
5	1-654-010051-13	SCREW,HX CP,3/8-16UNCX3, GR5	4
6	1-512-010005-05	NUT, HEX, SLFLKG GRB 3/8-16	4
7	6J766	HUB & SPINDLE ASM (SEE FIGURE 1-4)	4
8	6K921	WHEEL 8J791/NO TUBE/6D312 (SEE FIGURE 1-5)	4
9	5C100	WHEEL BOLT 1/2-20X1 GR5 ZP	24

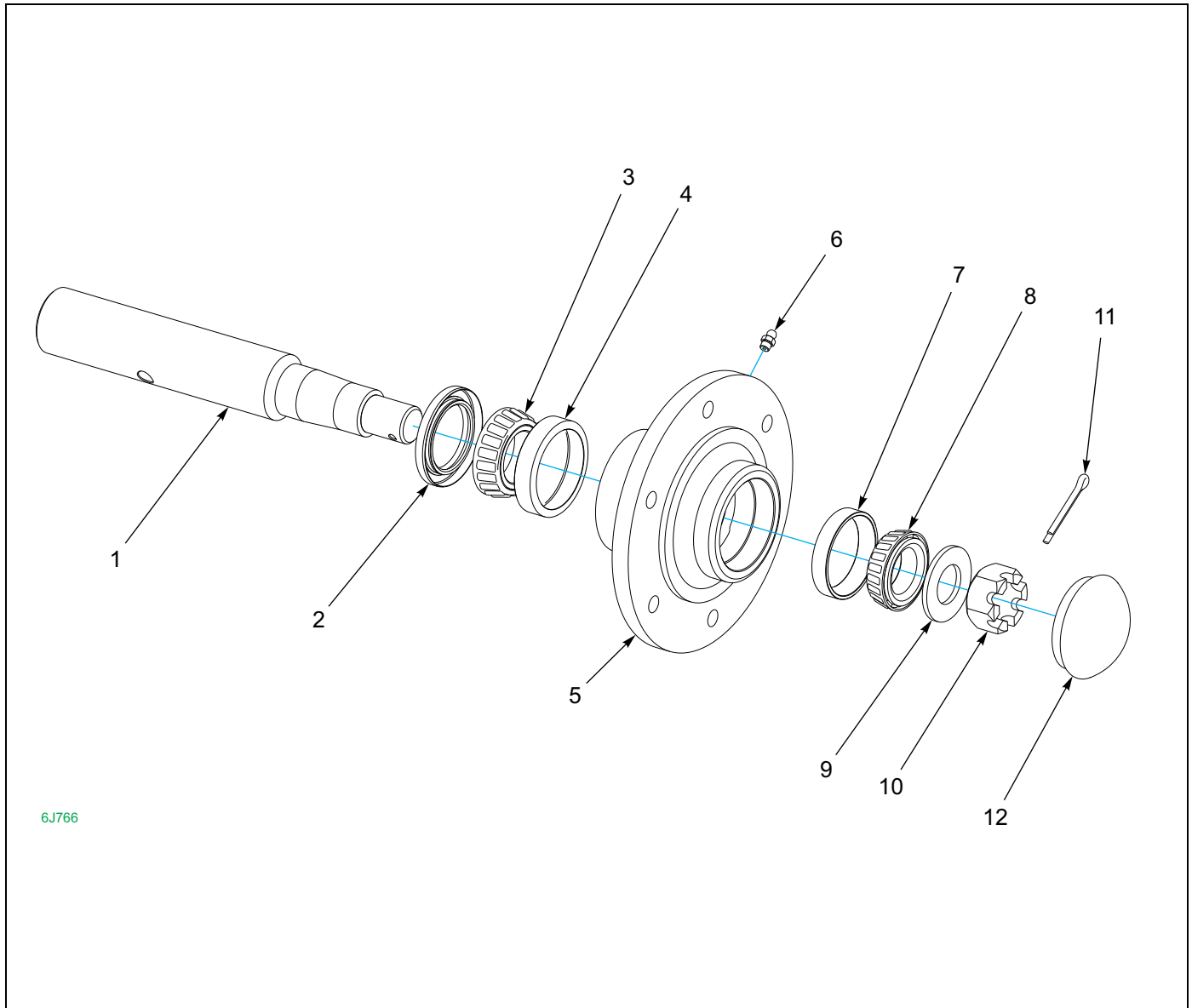

Figure 1-4: Hub and Spindle

Hub and Spindle

ITEM	PART NUMBER	DESCRIPTION	QTY.
	6J766	HUB & SPINDLE ASM	
1	6J765	SPINDLE	4
2	6D338	SEAL	4
3	712099	OUTER BEARING CONE (LM48548)	4
4	2107649	CUP, INNER BEARING (LM48510)	4
5	6D336	WHEEL HUB - 6 BOLT (INCLUDES ITEM 6)	4
6	1-298-010001-1	ZERK FITTING 1/4 SAE	4
7	1-076-010010	CUP INNER (LM67010)	4
8	1-076-010007	CONE INNER (LM67048)	4
9	1-861-010032-24	WASHER FL 1IN NARROW ZP	4
10	1-516-010001-20	NUT, HX SLOT 1-14	4
11	1-557-010362-51	PIN, COTTER 3/16X1-1/2	4
12	1-161-010003	CAP 6BOLT HUB	4

ILLUSTRATED PARTS LIST

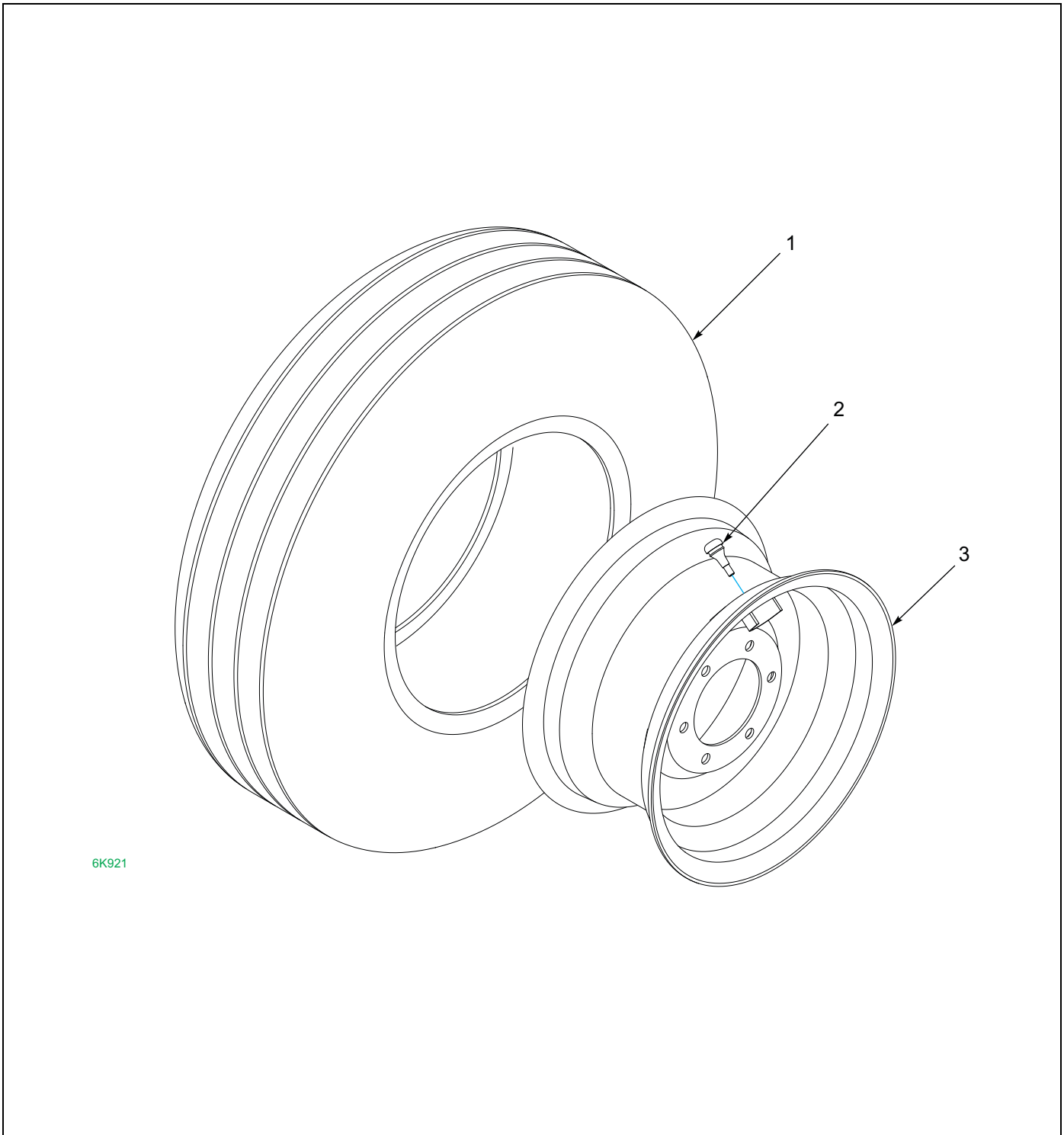

Figure 1-5: Wheel Assembly

Wheel Assembly

ITEM	PART NUMBER	DESCRIPTION	QTY.
	6K921	WHEEL 8J791/NO TUBE/6D312	
1	8J791	TIRE - 11L X 15 - 8 PLY	4
2	415	VALVE SREM	4
3	6D312	WHEEL - 15 X 8LB - 6 BOLT	4

ILLUSTRATED PARTS LIST

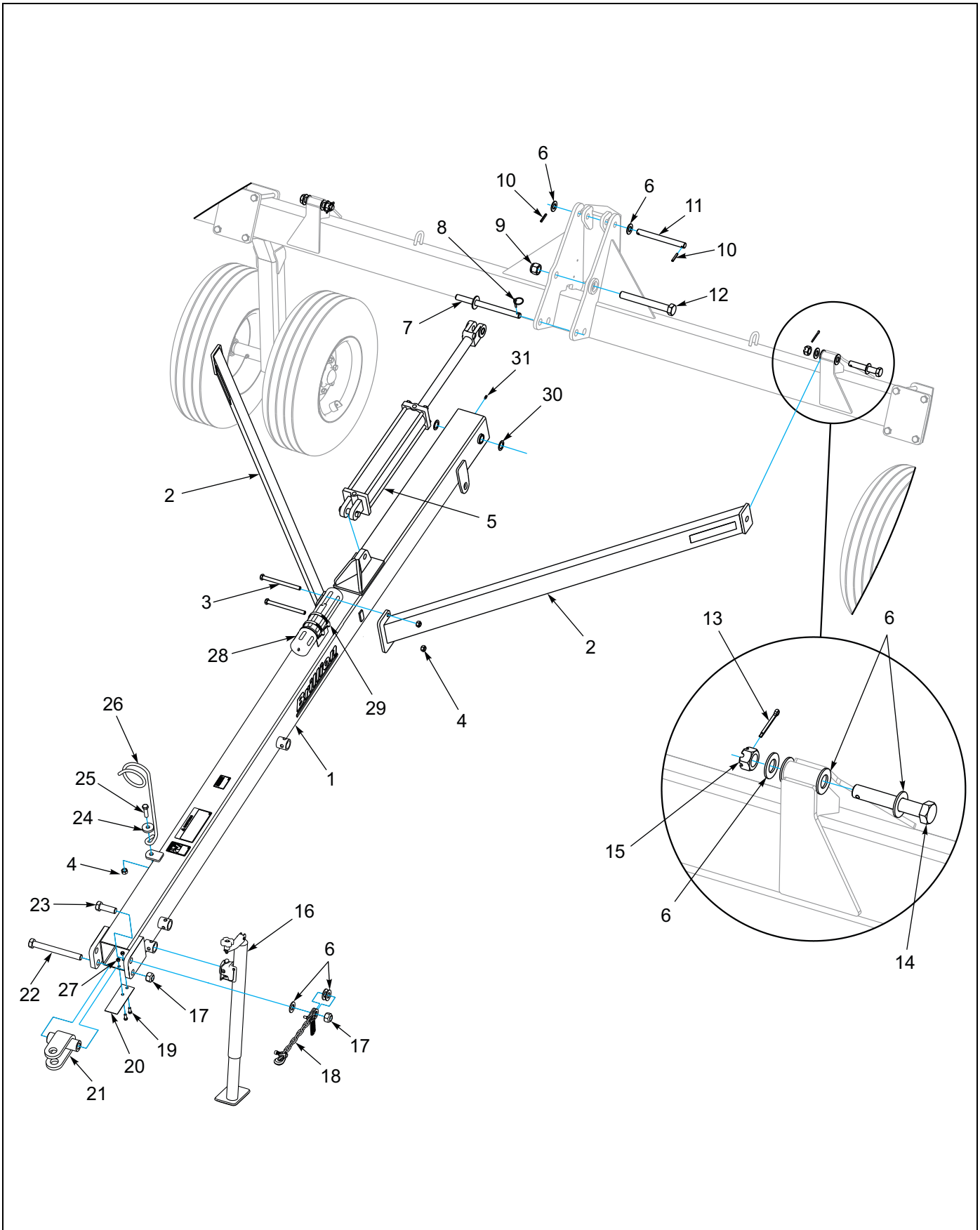

Figure 1-6: Drawbar

Drawbar

ITEM	PART NUMBER	DESCRIPTION	QTY.
1	4K955	DRAWBAR ASSEMBLY	1
2	4K971	BRACE	2
3	1-654-010059-21	SCREW,HEX CAP,5/8-11UNCX8 GR5	2
4	1-512-010005-13	NUT,HEX SLFLKG GRB 5/8-11	3
5	1-242-010180-3	CYLINDER,HYD 4X20STRK 3000PSI	1
6	1-861-010032-24	WASHER FL 1IN NARROW ZP	11
7	9J015	PIN	1
8	1-557-010327	PIN LYNCH 1/4X1-1/4	1
9	101385	NUT,HEX SLFLKG, 1-1/4-7 GRB	1
10	147072	PIN, SPRING SLOTTED 5/16 X 2	2
11	2P280	PIN, 1.0 X 10.125 H2	1
12	7K664	BOLT	1
13	1-557-010362-63	PIN,COTTER 1/4X2 ZP	2
14	2P160	BOLT, DRILLED 1-8X6	2
15	102931	NUT, HX SLOT 1-8	2
16	4J867	DRAWBAR JACK	1
17	1-512-010005-19	NUT, LOCK 1-8, GRB, ZP	2
18	141433	SAFETY CHAIN 11,000LB	1
19	1-654-010051-05	SCREW,HEX CAP 3/8-16UNCX1 GR5	2
20	6D865	STRAP	1
21	9D227	CLEVIS ASSEMBLY	1
22	1K557	BOLT, 1-8 X 9-1/2, GR5	1
23	3J608	HHCS, 1-8 X 3, GR5 ZP	1
24	6K970	WASHER 0.656 X 2.063 X 0.375ZP	1
25	1-654-010059-06	SCREW, HEX CAP 5/8-11X2-1/4 G5	1
26	6D333	HOSE SUPPORT	1
27	1-512-010005-05	NUT, HEX, SLFLKG GRB 3/8-16	2
28	1-116-010019	BOX, MANUAL STORAGE	1
29	105-0093	HOSE CLAMP 4-1/2 IDEAL #5264	2
30	4J548	MACH BUSH, 1.125 X 1.875 X 14GA	2
31	1-298-010001-1	ZERK FITTING 1/4 SAE	1

ILLUSTRATED PARTS LIST

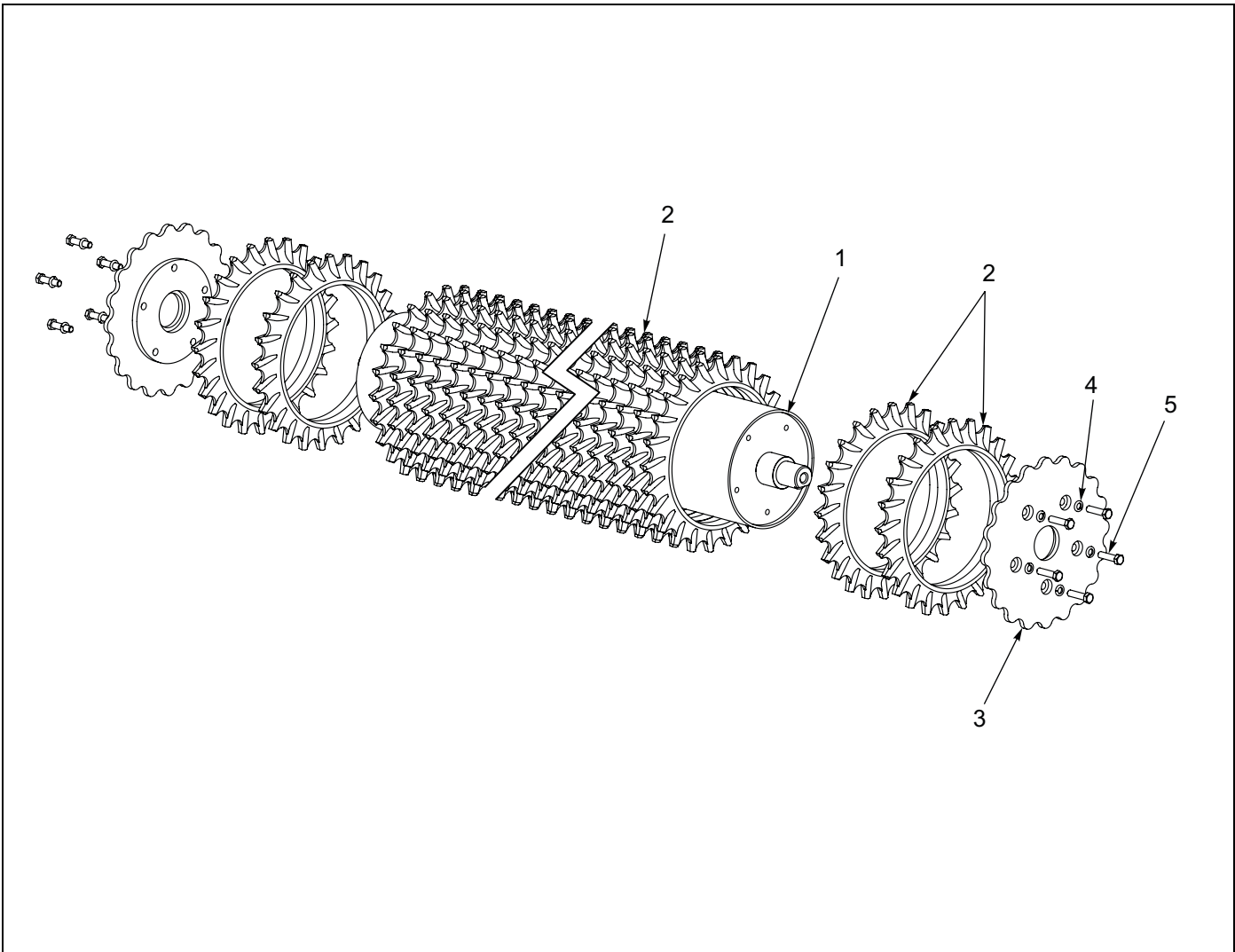

Figure 1-7: Floating Ring Roller Assembly

Floating Ring Roller Assembly - 20'

ITEM	PART NUMBER	DESCRIPTION	QTY.
	185969	ROLLER ASM, FLOATING RING 20'	
1	185968	AXLE,22' WLD	1
2	4K392	WHEEL,20" X 24 TEETH	97
3	188017	RETAINER WHEEL	2
4	1-861-010034-15	WASHER,LKG,HLCL SPR, 5/8	10
5	1-654-010059-07	SCREW HX CP 5/8-11UNCX2-1/2 GR5	10

Floating Ring Roller Assembly - 22'

ITEM	PART NUMBER	DESCRIPTION	QTY.
	185969	ROLLER ASM, FLOATING RING 20'	
1	185968	AXLE,22' WLD	1
2	4K392	WHEEL,20" X 24 TEETH	107
3	188017	RETAINER WHEEL	2
4	1-861-010034-15	WASHER,LKG,HLCL SPR, 5/8	10
5	1-654-010059-07	SCREW HX CP 5/8-11UNCX2-1/2 GR5	10

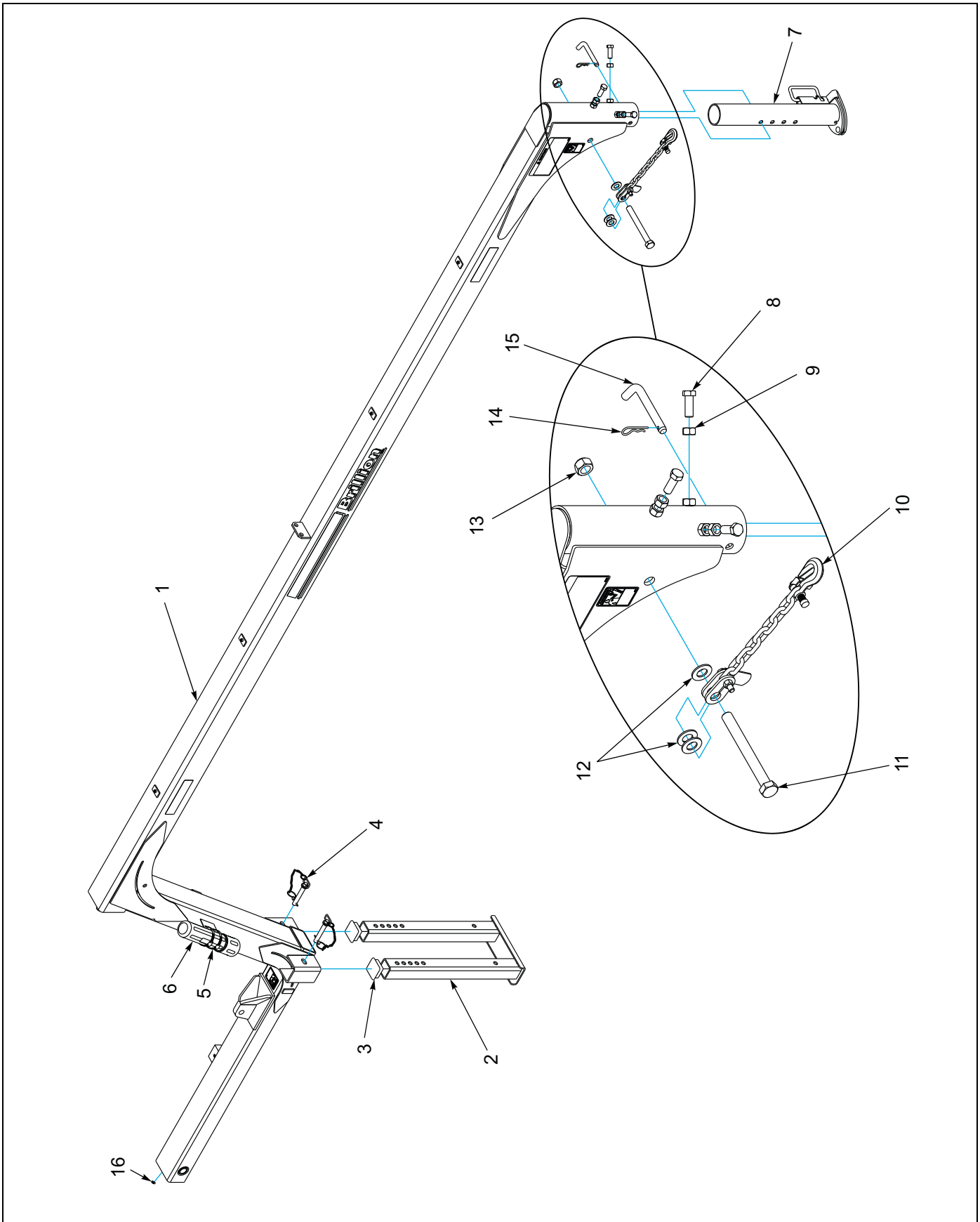

Figure 1-8: Bridge Hitch

Bridge Hitch

ITEM	PART NUMBER	DESCRIPTION	QTY.
1	2P131	HITCH, BRIDGE WLD	1
2	2P146	STAND, DOUBLE	1
3	7K672	CAP, PLUG	2
4	3P007	PIN, 3/4 W/CHAIN	1
5	105-0093	HOSE CLAMP 4-1/2 IDEAL #5264	2
6	1-116-010019	BOX, MANUAL STORAGE	1
7	2P135	GOOSENECK COUPLER	1
8	1-654-010061-05	SCREW,HHC 3/4-10UNCX2 GR5 ZP	3
9	1-512-010007-12	NUT, HEX 3/4-10 GR2 ZP	3
10	141433	SAFETY CHAIN 11,000LB	1
11	154888	SCREW HEX CAP, 1-8UNCX9 GR5	1
12	1-861-010032-24	WASHER FL 1IN NARROW ZP	3
13	1-512-010005-19	NUT 1-8 HEX SLF-LOCKING GRB	1
14	4C856	HAIR PIN COTTER	1
15	2P136	PIN, BENT HITCH 3/4	1
16	1-298-010001-1	ZERK FITTING 1/4 SAE	1

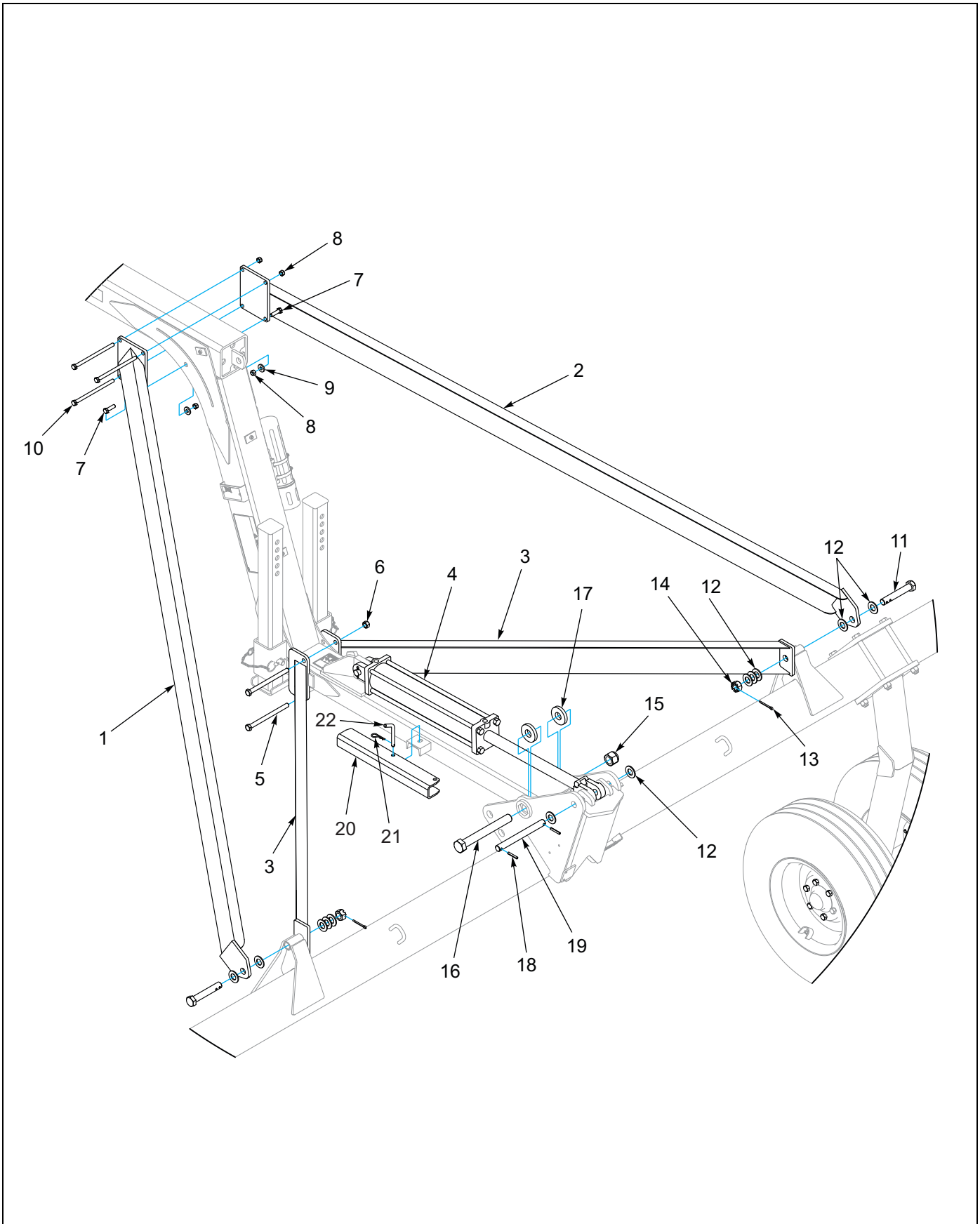

Figure 1-9: Bridge Hitch Braces

Bridge Hitch Braces

ITEM	PART NUMBER	DESCRIPTION	QTY.
1	2P149	BRACE,HITCH LH	1
2	2P150	BRACE,HITCH RH	1
3	4K971	BRACE	2
4	1-242-010180-3	CYLINDER, HYD 4X20 STRK 3000PSI (SEE FIGURE 1-13)	1
5	5D366	HHCS, 5/8-11 X 8-1/2, GR5	2
6	1-512-010005-13	NUT,HEX SLFLKG GRB 5/8-11	2
7	1-654-010055-04	SCREW, HEX CAP, 1/2-13UNCX1-3/4	2
8	1-512-010005-09	NUT,HEX,SLFLKG, 1/2-13 GRB	5
9	5J492	WASHER,1/2 X 1-1/4 X3/16	2
10	1-654-010055-22	HHCS, 1/2-13 X 8 1/2, GR5	3
11	2P160	BOLT, DRILLED 1-8X6	2
12	1-861-010032-24	WASHER FL 1IN NARROW ZP	12
13	1-557-010362-63	PIN,COTTER 1/4X2 ZP	2
14	102931	NUT, HEX SLOT 1-8 ZP	2
15	101385	NUT,HEX SLFLKG, 1-1/4-7 GRB	1
16	7K664	BOLT, 1-1/4-7 X 10-1/2, GR5	1
17	188049	WASHER, 1.28 3.0 X 0.5	4
18	147072	PIN,SPRING SLOTTED 5/16 X 2	2
19	2P280	PIN, 1 X 10-1/8	1
20	174291	TRANSPORT LOCK 1-3/4 X 20	1
21	6J448	HAIRPIN COTTER 1/8	1
22	3C335	BENT PIN	1

ILLUSTRATED PARTS LIST

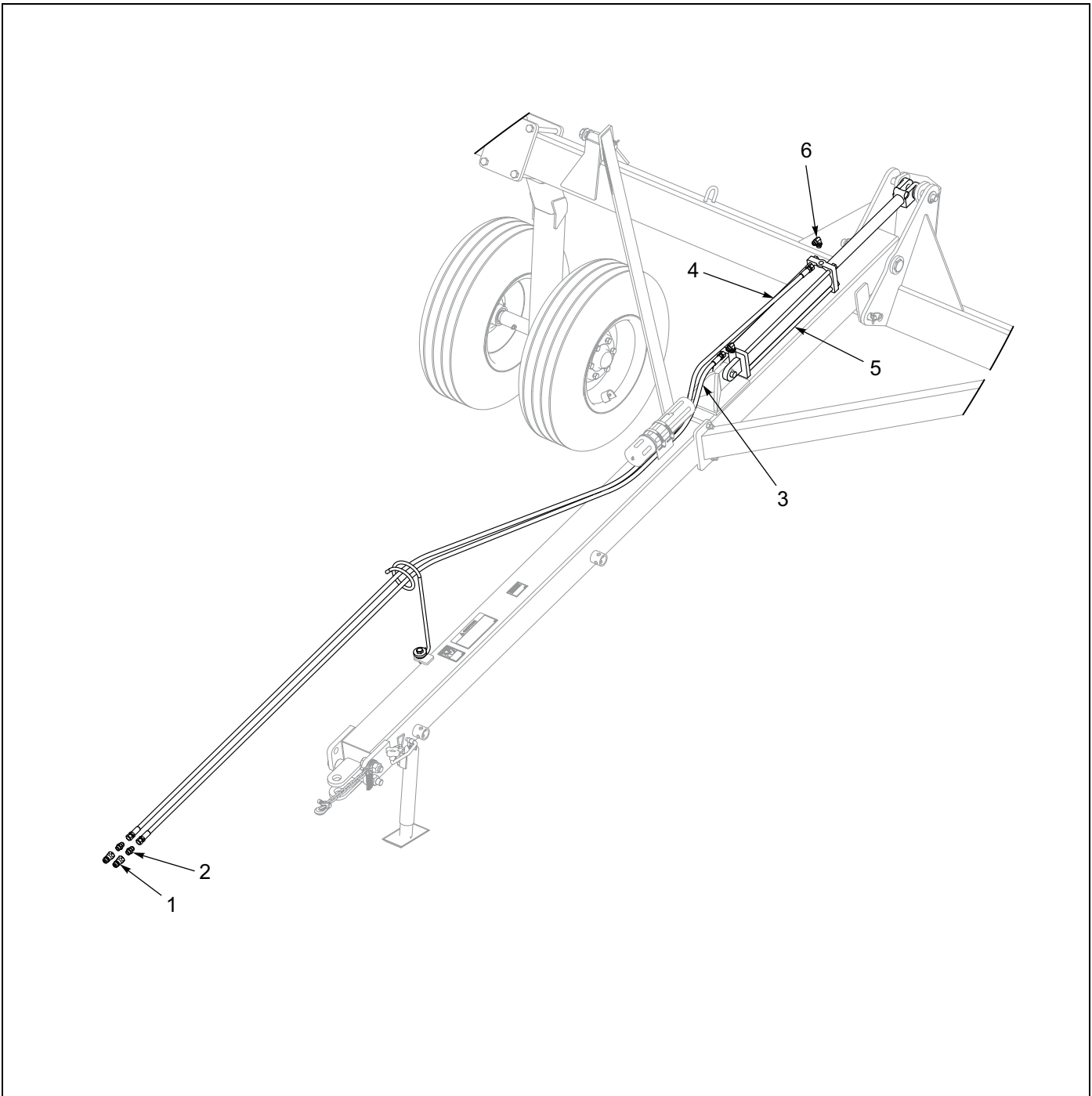

Figure 1-10: Hydraulics

Hydraulics

ITEM	PART NUMBER	DESCRIPTION	QTY.
1	141828	COUPLER,MALE 3/4-16 O-RING	2
2	202702-8-8S	ADAPTER #8 O-RING TO #8 TUBE	2
3	159569	HOSE ASSY 3/8X161 #8 JIC SWVL	1
4	150273	HOSE ASSY 3/8X185 #8 JIC SWVL	1
5	1-242-010180-3	CYLINDER, HYD 4X20STRK 3000PSI (SEE FIGURE 1-13)	1
6	141826	ELBOW 90 1/16 RES	2

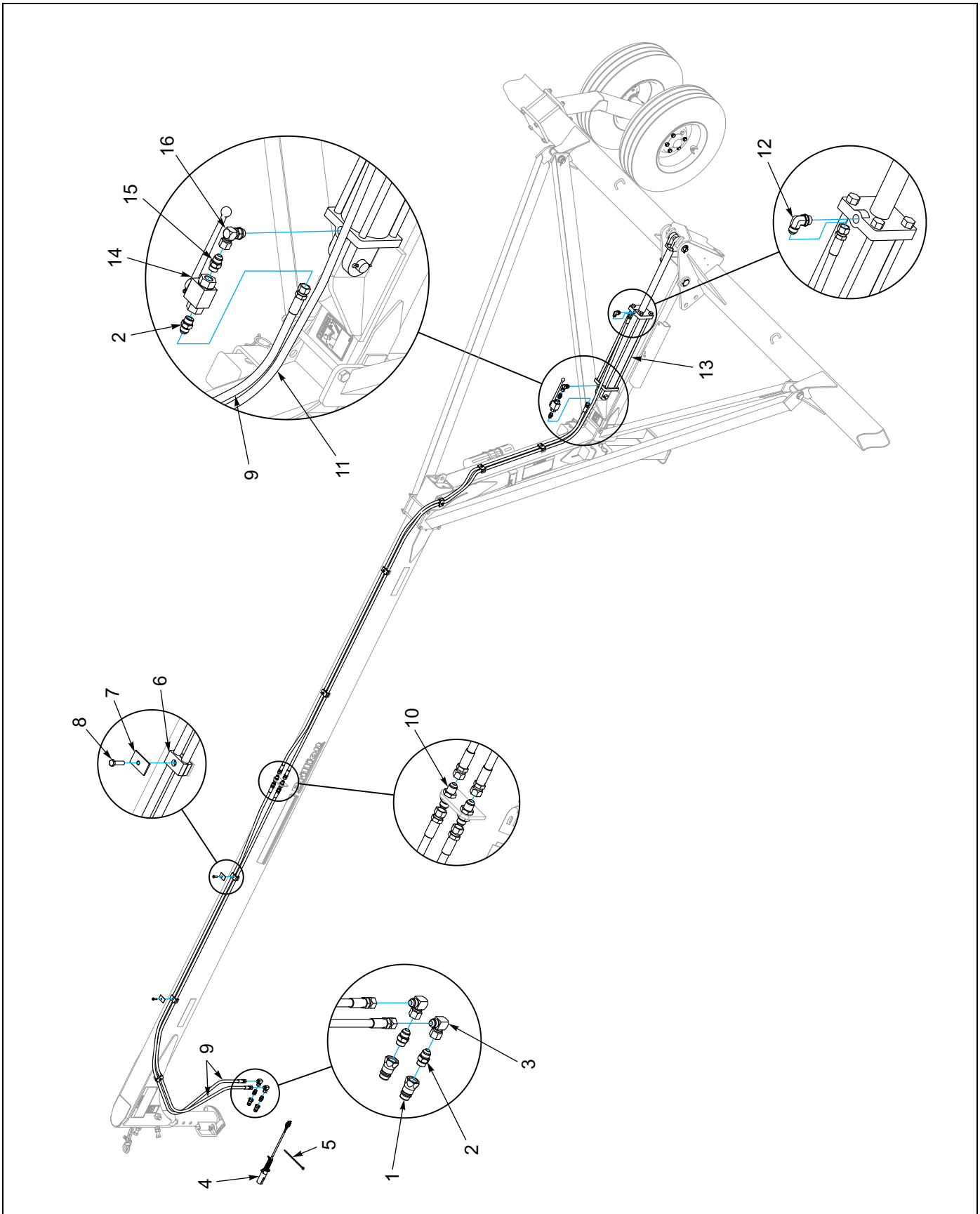

Figure 1-11: Bridge Hitch Hydraulics

Bridge Hitch Hydraulics

ITEM	PART NUMBER	DESCRIPTION	QTY.
1	141828	COUPLER,MALE 3/4-16 O-RING	2
2	202702-8-8S	ADAPTER #8 O-RING TO #8 TUBE	3
3	2071-8-8S	ADAPTER90 #8 FLR SWIVEL #8JIC	2
4	174438	HARNESS, MAIN WARNING LIGHTS	1
5	105-0228	TYWRAP 8IN LG TY-5272MX	10
6	1P937	TWIN CLAMP PAIR, .67" DIA	8
7	1P938	TWIN TOP PLATE	8
8	1-654-010049-06	SCREW,H/CAP, 5/16-18UNC X 1-1/4	8
9	144342	HOSE ASSY 3/8X150 #8 JIC SWIV	3
10	102-0322	37 FLARE BULKHEAD/37 FLARE	2
11	141864	HOSE ASSY 3/8X175 #8 JIC SWVL	1
12	141826	ELBOW 90 1/16 RES (08MJ X 08MOR X .063)	2
13	1-242-010180-3	CYLINDER, HYD 4X20STRK 3000PSI (SEE FIGURE 1-13)	1
14	8K643	BALL SHUT-OFF VALVE	1
15	4K607	RESTRICTOR (08MJ X 08MOR X .078)	1
16	2P140	ELBOW, 08MOR X 08FJS X 90DEG	1

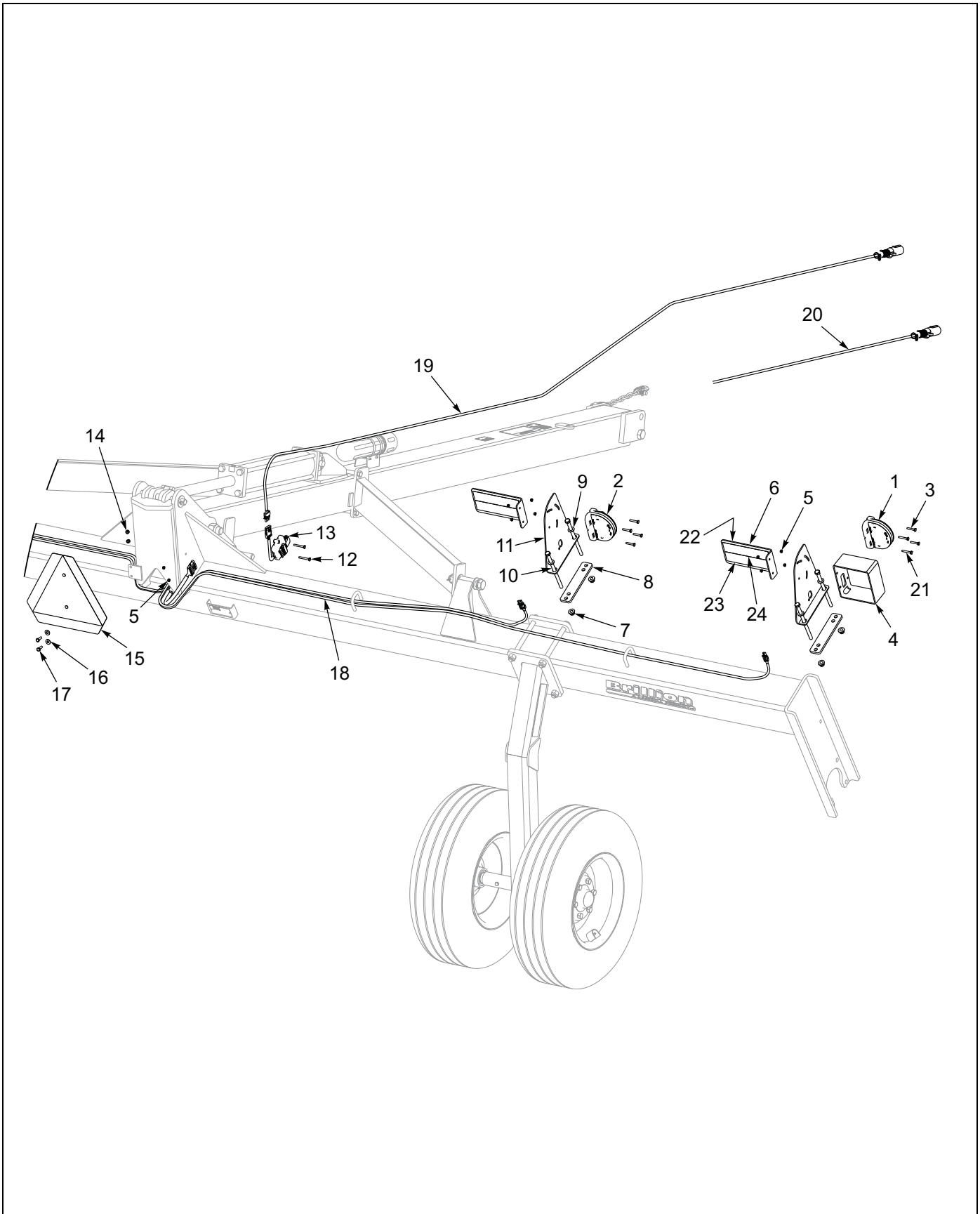

Figure 1-12: Electrical Layout

Electrical Layout

ITEM	PART NUMBER	DESCRIPTION	QTY.
1	174436	LAMP, AG AMBER SINGLE LED	2
2	174435	LAMP, AG RED SINGLE LED	2
3	1-654-010047-08	SCREW,HX CP. 1/4-20UNCX1-1/2 G5	12
4	164700	TUBE LIGHT SHIELD	2
5	1-512-010005-01	NUT,HEX SLFLKG GRB 1/4-20	18
6	164697	PLATE CONSPICUITY DECAL MOUNT	4
7	2P253	NUT, FLANGE NY-LOK 1/2-13	8
8	4K970	STRAP	4
9	1-861-010032-14	WASHER, FLAT 1/2" N ZP/CD	8
10	1-654-010055-22	SCREW HEX CAP 1/2-13X8-1/2	8
11	188040	BRACKET, LIGHTMOUNT	4
12	1-654-010047-10	SCREW, HX CP, 1/4-20UNC X2 GR5	2
13	174437	MODULE, AG FLASHER CONTROL	1
14	104032	NUT,HX SLF-LKG W/MYL 5/16-18	2
15	2P151	SMV W/BRACKET	1
16	1-861-010032-09	WASHER, FLAT 5/16 W ZP/CD	2
17	1-654-010049-05	SCREW HX CP 5/16-18UNCX1 GR5	2
18	178513	HARNESS, LAMP 66 X 138	1
19	178516	HARNESS, 7 PIN/4 PIN WP, 20'	1
20	174438	HARNESS, MAIN WARNING LIGHTS (USED WITH BRIDGE HITCH)	1
21	1-654-010047-09	SCREW,HX CP. 1/4-20UNCX1-3/4 G5	4
22	528934	REFLECTOR - YELLOW	4
23	528938	STRIPE, ORANGE	4
24	528933	REFLECTOR - RED	4
25	105-0228	TYWRAP 8IN LG TY-5272MX (NOT SHOWN)	12
26	7K678	CABLE TIE (NOT SHOWN)	6

ILLUSTRATED PARTS LIST

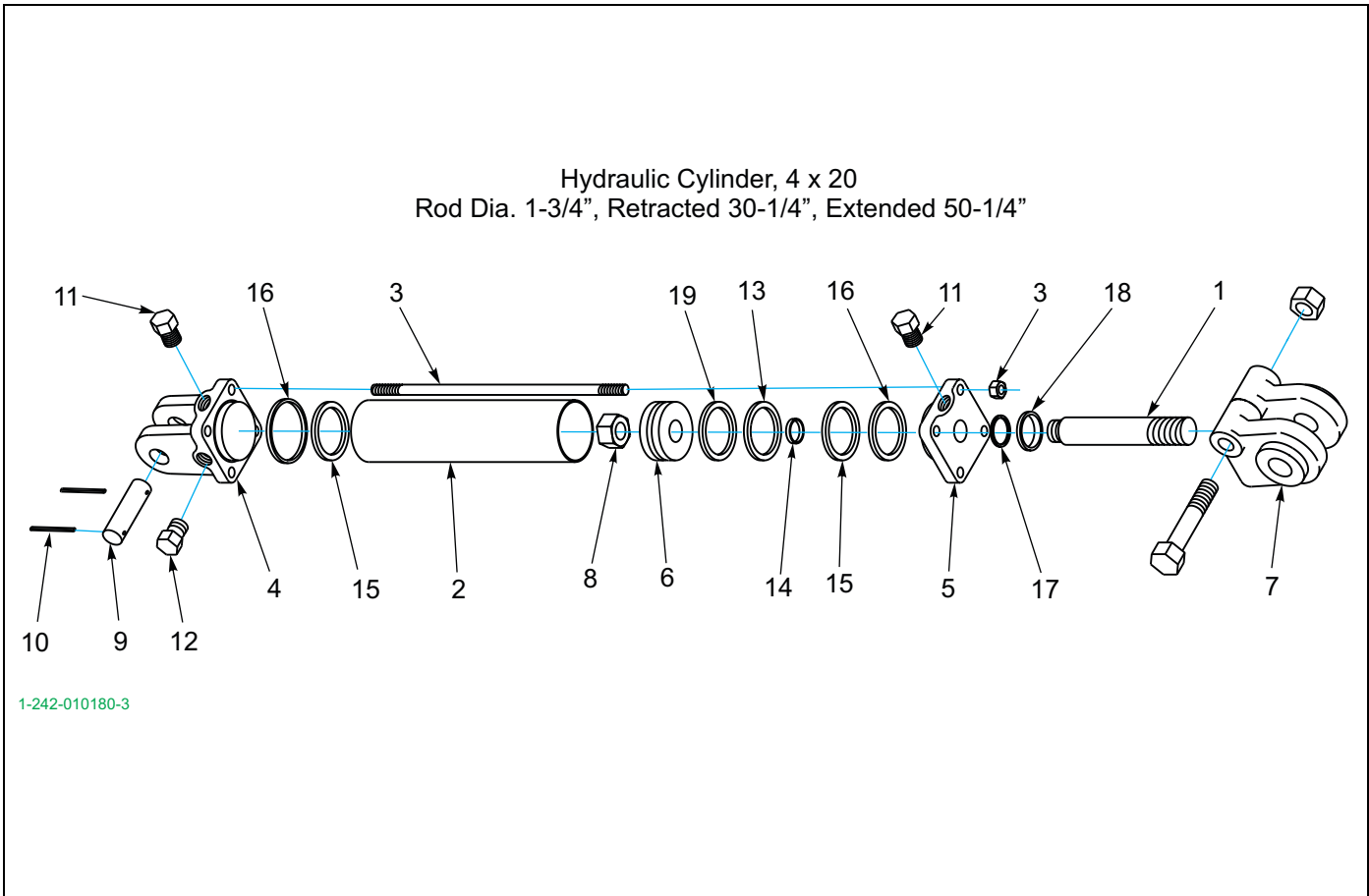

Figure 1-13: Hydraulic Cylinder, 4 x 20

Hydraulic Cylinder, 4 X 20

ITEM	PART NUMBER	DESCRIPTION	QTY.
	1-242-010180-3	CYLINDER, HYD 4X20 STRK 3000PSI	
1	011000323	PISTON ROD 4X20 SAE34020	1
2		TUBE	1
3		TIE ROD ASSY	4
4		BUTT	1
5		GLAND ASSY	1
6		PISTON	1
7		CLEVIS ASSY	1
8		LOCKNUT	1
9	111790	PIN,CLEVIS #190400104 1500	2
10	111789	PIN,ROLL #190100057 1500	4
11		PLASTIC PLUG	2
12		PORT PLUG	1
13		CROWN SEAL	1
14		O-RING	1
15		O-RING	2
16		BU-WASHER	2
17		U-CUP	1
18		WIPER	1
19		BEARING RING	1
20	1-242-010178-3	CYLINDER PKG KIT 3000 PSI 4" (INCLUDES ITEMS 13-19)	REF

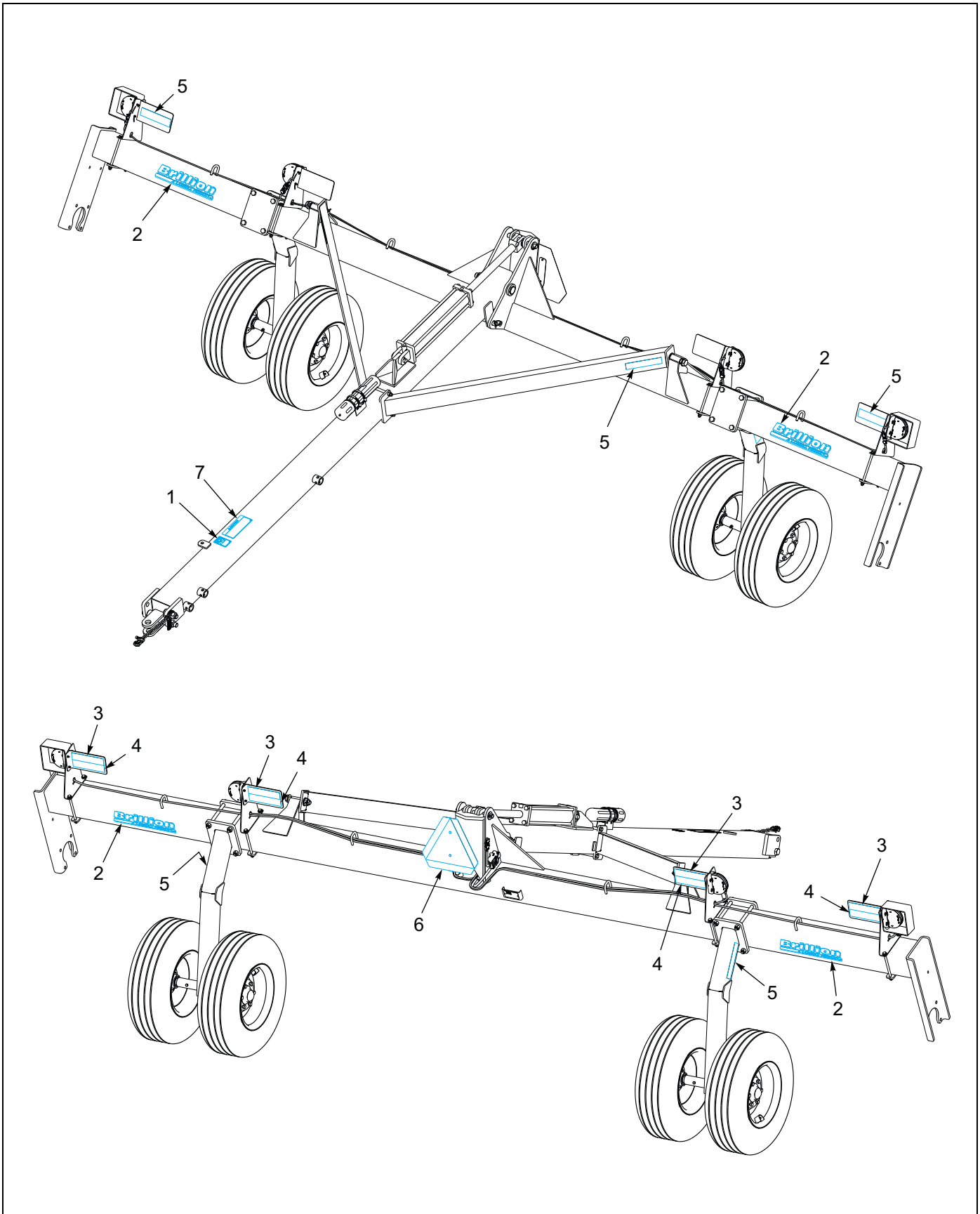

Figure 1-14: Decals

Decals

ITEM	PART NUMBER	DESCRIPTION	QTY.
1	3K706	DECAL-WARNING HYDRAULIC LEAKS	1
2	170510	DECAL - BRILLION LANDOLL	4
3	528938	STRIPE, ORANGE	4
4	528933	REFLECTOR - RED	4
5	528934	REFLECTOR - YELLOW	6
6	2P151	SMV W/BACKET	1
7	8J310	DECAL - CAUTION	1

Numerical Index

Numerics

011000323	1-22	1-512-010005-13	1-3, 1-9, 1-15
101385	1-9, 1-15	1-512-010005-15	1-4
102-0322	1-19	1-512-010005-19	1-9, 1-13
102931	1-9, 1-15	1-512-010007-12	1-13
104032	1-21	1-516-010001-20	1-5
104436	1-4	154185	1-3
105-0093	1-9, 1-13	154888	1-13
105-0228	1-19, 1-21	1-557-010327	1-9
1-076-010007	1-5	1-557-010362-51	1-5
1-076-010010	1-5	1-557-010362-63	1-9, 1-15
1-116-010019	1-9, 1-13	159569	1-16
111789	1-22	164697	1-21
111790	1-22	164700	1-21
1-161-010003	1-5	1-654-010047-08	1-21
1-242-010178-3	1-22	1-654-010047-09	1-21
1-242-010180-3	1-9, 1-15, 1-16, 1-19, 1-22	1-654-010047-10	1-21
1-298-010001-1	1-5, 1-9, 1-13	1-654-010049-05	1-21
137943	1-3	1-654-010049-06	1-19
141433	1-9, 1-13	1-654-010051-05	1-9
141826	1-16, 1-19	1-654-010051-13	1-4
141828	1-16, 1-19	1-654-010055-04	1-15
141864	1-19	1-654-010055-22	1-15, 1-21
144342	1-19	1-654-010059-04	1-3
147072	1-9, 1-15	1-654-010059-06	1-9
150273	1-16	1-654-010059-07	1-10
1-512-010005-01	1-21	1-654-010059-21	1-9
1-512-010005-05	1-4, 1-9	1-654-010061-05	1-13
1-512-010005-09	1-15	170510	1-25
		174291	1-15

NUMERICAL INDEX

174435	1-21	2P160	1-9, 1-15
174436	1-21	2P253	1-21
174437	1-21	2P280	1-9, 1-15
174438	1-19, 1-21	3C335	1-15
178513	1-21	3J608	1-9
178516	1-21	3K706	1-25
185166	1-3	3P007	1-13
185167	1-3	415	1-6
185170	1-3	4C856	1-13
185171	1-3	4J548	1-9
185968	1-10	4J867	1-9
185969	1-3, 1-10	4K392	1-10
1-861-010032-09	1-21	4K607	1-19
1-861-010032-14	1-21	4K955	1-9
1-861-010032-24	1-5, 1-9, 1-13, 1-15	4K970	1-21
1-861-010034-15	1-10	4K971	1-9, 1-15
1-861-010034-21	1-3	528933	1-21, 1-25
188010	1-4	528934	1-21, 1-25
188017	1-10	528938	1-21, 1-25
188024	1-3	5C100	1-4
188036	1-3	5D366	1-15
188037	1-3	5J492	1-15
188040	1-21	5K195	1-4
188049	1-15	6D312	1-6
1K557	1-9	6D333	1-9
1P937	1-19	6D336	1-5
1P938	1-19	6D338	1-5
202702-8-8S	1-16, 1-19	6D865	1-9
2071-8-8S	1-19	6J448	1-15
2107649	1-5	6J765	1-5
2P131	1-13	6J766	1-4, 1-5
2P135	1-13	6K921	1-4, 1-6
2P136	1-13	6K970	1-9
2P140	1-19	712099	1-5
2P146	1-13	7K664	1-9, 1-15
2P149	1-15	7K672	1-13
2P150	1-15	7K678	1-21
2P151	1-21, 1-25	8J310	1-25

8J791 1-6
8K643 1-19
9D227 1-9
9J015 1-9

Page Intentionally Blank

Chapter 3

Glossary

For clarity this glossary of industry standard abbreviations and their definitions are provided.

For additional information, See "Instructions for Ordering Parts" on page 1-1.

A

ASSY Assembly
ASM Assembly

B

BATT Battery
BHSC Button Head Socket Cap
BLK Black
BRG Bearing

C

CB Carriage Bolt
CONN Connector
CRG Carriage
CTSK Countersunk
CTWT Counterweight
CVR Cover
CYD Cylinder

D

DBL Double
DIA Diameter

E

ENCLSD Enclosed

F

FHCS Flanged Head Cap Screw
FHHCS Flanged Hex Head Cap Screw
FL OR FLG Flange
FLT Flat
FTG Fitting

G

GA Gauge
Gr Grade

H

HHCS Hex Head Cap Screw
HCS High Carbon Steel
HD Head
HLCL Helical
HCSKT Hex Socket
HYD Hydraulic

I

ID Inside Diameter

L

LH Lefthand
LKG OR LOCK Locking
LWR Lower

M

MANF Manifold
MNT Mount

GLOSSARY

N

NRW Narrow
NSS Not Serviced Separately

O

OD Outside Diameter
OHG Overhead Guard
ORFS OR ORS O-Ring Seal
ORP OR ORB O-Ring Boss

P

P-STEER Power Steering
PTFE Polytetrafluoroethylene (Teflon)

R

RH Righthand
RND Round

S

SER Series
SHCS Socket Head Cap Screw
SHLD Shield
SKT Socket
SLFLKG Selflocking
SOC Socket
SPDT Single Pole Double Throw
SPR Spring
SQ Square
SRTD Serrated
SSCR Setscrew
SST Stainless Steel
STD Standard

U

UPR Upper

W

WHL Wheel
WLD OR WLDMT Weldment

Z

ZP Zinc Plated

Document Control Revision Log:

Date	Revision	Improvement(s) Description and Comments	Team Member
01/2015	R0	Initial Release	WML



Intertek

Equipment from Landoll Corporation is built to exacting standards ensured by ISO 9001 registration at all Landoll manufacturing facilities.

Floating Ring Pulverizer PFT 20' and 22' Models Parts Manual

Re-Order Part Number F-779R0

LANDOLL CORPORATION

1900 North Street

Marysville, Kansas 66508

(785) 562-5381

800-428-5655 ~ WWW.LANDOLL.COM



Copyright 2014. Landoll Corporation

“All rights reserved, including the right to reproduce this material or portions thereof in any form.”