

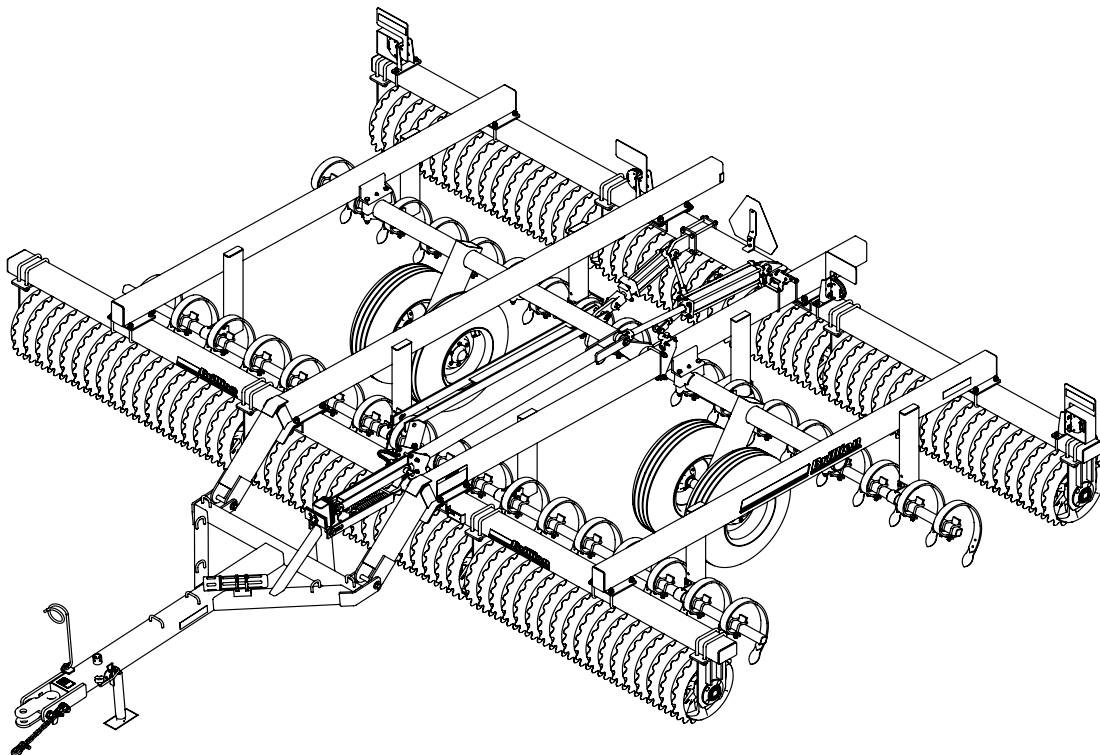

18' 9" RIGID PULVI-MULCHER
Models: ML, MLS, MCL, MLC, MCC, MCLS,
MLCS, and MCCS 2253
Operator's Manual



LANDOLL CORPORATION

1900 North Street
Marysville, Kansas 66508
(785) 562-5381

800-428-5655 ~ WWW.LANDOLL.COM

Table of Contents

1 Introduction and Safety Information

Introduction	1-1
Description of Unit	1-1
Owner Assistance	1-1
Warranty Registration	1-1
Safety	1-2
Understanding Safety Statements	1-2
Transporting Safety	1-2
Attaching, Detaching and Storage	1-2
Maintenance Safety	1-3
Protective Equipment	1-3
High Pressure Fluid Safety	1-3
Tire Safety	1-3
Safety Chain	1-3
Decals	1-4

2 Assembly

Frame Assembly	2-1
Rockshaft Installation	2-4
Transport Axle Link Installation	2-6
Drawbar Installation	2-8
Spring Linkage Assembly	2-9
Roller Installation	2-10
Bracket Assembly	2-13
Tooth Tube Bracket Locations	2-14
Tooth Control Installation	2-15
S-Tine Installation	2-16
C-Tooth Installation	2-17
Independent Tooth Control C-Tooth Installation	2-19
Independent Tooth Control S-Tine Installation	2-20
Bracket Relationship per Tine Style - Independent	2-21
Hydraulics	2-22

Transport Circuit	2-22
Independent Tooth Control Circuit	2-22
Bleeding Hydraulic System	2-22
Transport Hydraulic Diagram	2-23
Independent Tooth Control - Hydraulic Diagram	2-23
LED Lamp and Harness Installation	2-25
Scrapers - Standard on Rear	2-28
Rear Hitch - Optional	2-29
Land Leveler - Optional	2-30
V Leveler - Optional	2-31

3 Operation

General Operation	3-1
Level Adjustment	3-2
Spring Adjustment	3-2
Transport Lock After July 2016	3-3
Transport Lock Prior to July 2016	3-4
Depth Control	3-5
Charging the Hydraulic System	3-6
Hydraulic Lift Circuit	3-6
Tooth Control Circuit	3-6
Reflectors and SMV Sign	3-6
Transport	3-7
Wheel Adjustment	3-8
Scraper Adjustment	3-8
Land Leveler - Optional	3-8
V Leveler - Optional	3-8

4 Maintenance

General Torque Specifications	4-1
Hydraulic Fitting Torque Specifications	4-2
Fasteners	4-2
Tires	4-3
Wheel Bearing Maintenance	4-3
Lubrication	4-3
Hydraulic Maintenance	4-4
C-Tooth Point Replacement	4-4
Clamp Tightening Procedure	4-5
Storage	4-6

5 General Reference and Specifications

Introduction and Safety Information

Introduction

The implement described in this manual has been designed with care and built by skilled workers using quality materials and processes. Proper assembly and maintenance will provide you with satisfactory use for seasons to come.



DANGER

Read this entire manual before attempting to assemble, adjust or operate this implement. Failure to comply with this warning can result in personal injury or death, damage to the implement or its components and inferior operation.

Description of Unit

The front rollers of the Brillion Pulvi-Mulcher break up surface clods. Conventional "C" teeth or "S-Tine" teeth loosen the soil up to 6" in depth and pull clods to the surface. The rear roller wheels then crush those clods and convert the soil into a firm, mulched seedbed that locks in moisture at the root level. The result is a uniformly firm and tilled seedbed from top to bottom, but not compacted. The growing environment receives the full benefit of capillary action of the soil for better germination, better moisture retention and faster decomposition of residue.

Using this Manual

This manual will familiarize you with safety, assembly, operation, adjustment, and maintenance. Read this manual and follow the recommendations to help ensure safe and efficient operation.

- The information in this manual is current at time of printing. Some parts may have changed to assure top performance.
- Location reference: Right and Left designations in this manual are determined by facing the direction the implement will travel during field operation, unless otherwise stated.

Owner Assistance

If customer service or repairs are needed, contact your Brillion dealer. They have trained personnel, parts and service equipment specially designed for Brillion products. Your implement's parts should only be replaced with Brillion parts. If items covered in this manual are not understood, contact your local Brillion Dealer.

Warranty Registration

Brillion Farm Equipment, by Landoll, shall have no warranty obligation unless each product is registered within 10 days of retail purchase, using the Landoll Corporation Ag Products on-line registration process. Please refer to the Ag Products Policy and Procedures Manual, accessible at www.landoll.com for step by step instructions regarding product registration.

Enter your product information below for quick reference.

MODEL NUMBER _____

SERIAL NUMBER _____

DATE OF PURCHASE _____

Refer to the ID plate as shown. See Figure 1-1.

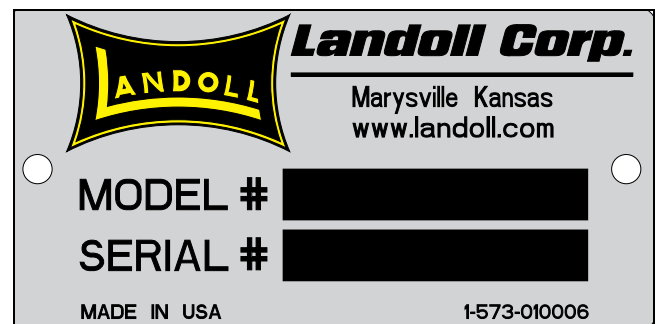

Figure 1-1: ID Plate

Safety

NOTE

Investigation has shown that nearly 1/3 of all farm accidents are caused by careless use of machinery. Insist that all people working with you or for you abide by all safety instructions.

Understanding Safety Statements

You will find various types of safety information on the following pages and on the implement decals (signs) attached to the implement. This section explains their meaning.

NOTICE

Special notice - read and thoroughly understand.



CAUTION

Proceed with caution. Failure to heed caution may cause injury to person or damage product.



WARNING

Proceed with caution. Failure to heed warning will cause injury to person or damage product.



DANGER

Proceed with extreme caution. Failure to heed notice will cause injury or death to person and/or damage product.

NOTE

You should read and understand the information contained in this manual and on the implement decals before you attempt to operate or maintain this equipment.

Examine safety decals and be sure you have the correct safety decals for the implement. **See Figure 1-3.**

Order replacement decals through your Brillion dealer.

Keep these signs clean so they can be observed readily. It is important to keep these decals cleaned more frequently than the implement. Wash with soap and water or a cleaning solution as required.

Replace decals that become damaged or lost. Also, be sure that any new implement components installed during repair include decals which are assigned to them by the manufacturer.

When applying decals to the implement, be sure to clean the surface to remove any dirt or residue. Where possible, sign placement should protect the sign from abrasion, damage, or obstruction from mud, dirt, oil etc.



DANGER

- Do not allow anyone to ride on the tractor or implement. Riders could be struck by foreign objects or thrown from the implement.
- Never allow children to operate equipment.
- Keep bystanders away from implement during operation.

Transporting Safety

IMPORTANT

It is the responsibility of the owner/operator to comply with all state and local laws.

When transporting the implement on a road or highway, use adequate warning symbols, reflectors, lights and slow moving vehicle sign as required. Slow moving tractors and towed implements can create a hazard when driven on public roads. They are difficult to see, especially at night.

Do not tow an implement that, when fully loaded, weighs more than 1.5 times the weight of the towing vehicle.

Carry reflectors or flags to mark the tractor and implement in case of breakdown on the road.

Do not transport at speeds over 20 MPH under good conditions. Never travel at a speed which does not allow adequate control of steering and stopping. Reduce speed if towed load is not equipped with brakes

Avoid sudden stops or turns because the weight of the implement may cause the operator to lose control of the tractor. Use a tractor heavier than the implement.

Use caution when towing behind articulated steering tractors; fast or sharp turns may cause the implement to shift sideways.

Keep clear of overhead power lines and other obstructions when transporting. Know the transport height and width of your implement.

Attaching, Detaching and Storage

- Do not stand between the tractor and implement when attaching or detaching implement unless both are blocked from moving.
- Block implement so it will not roll when unhitched from the tractor.

Maintenance Safety

- Block the implement so it will not roll when working on or under it to prevent injury.
- Do not make adjustments or lubricate the machine while it is in motion.
- Make sure all moving parts have stopped.
- Understand the procedure before doing the work. Use proper tools and equipment.

Protective Equipment

- Wear protective clothing & equipment appropriate for the job. Avoid loose fitting clothing.
- Because prolonged exposure to loud noise can cause hearing impairment or hearing loss, wear suitable hearing protection, such as earmuffs or earplugs.

High Pressure Fluid Safety

Escaping fluid under pressure can be nearly invisible and have enough force to penetrate the skin causing serious injury. Use a piece of cardboard, rather than hands, to search for suspected leaks.

Any fluid injected into the skin must be surgically removed within a few hours or gangrene may result.

Avoid the hazard by relieving pressure before disconnecting hydraulic lines.

Tire Safety

Tire changing can be dangerous and should be performed by trained personnel using correct tools and equipment.

When inflating tires, use a clip-on chuck and extension hose long enough to allow you to stand to one side, not in front of or over the tire assembly. Use a safety cage if available.

When removing and installing wheels use wheel-handling equipment adequate for the weight involved.

Safety Chain

Use the safety chain to help control drawn machinery should it separate from the tractor drawbar.

Use a chain with a strength rating equal to or greater than the gross weight of towed machinery, which is 10,100 pounds minimum in accordance with ASAE S338.2 specifications. If two or more implements are pulled in tandem, a larger chain may be required. Chain capacity must be greater than the TOTAL weight of all towed implements.

A second chain should be used between each implement.

Attach the chain to the tractor drawbar support or specified anchor location. Allow only enough slack in the chain to permit turning. The distance from hitch pin to attachment point or intermediate support point should not exceed 9 inches. **See Figure 1-2.**

Replace the chain if any links or end fittings are broken, stretched or damaged.

Do not use a safety chain for towing.

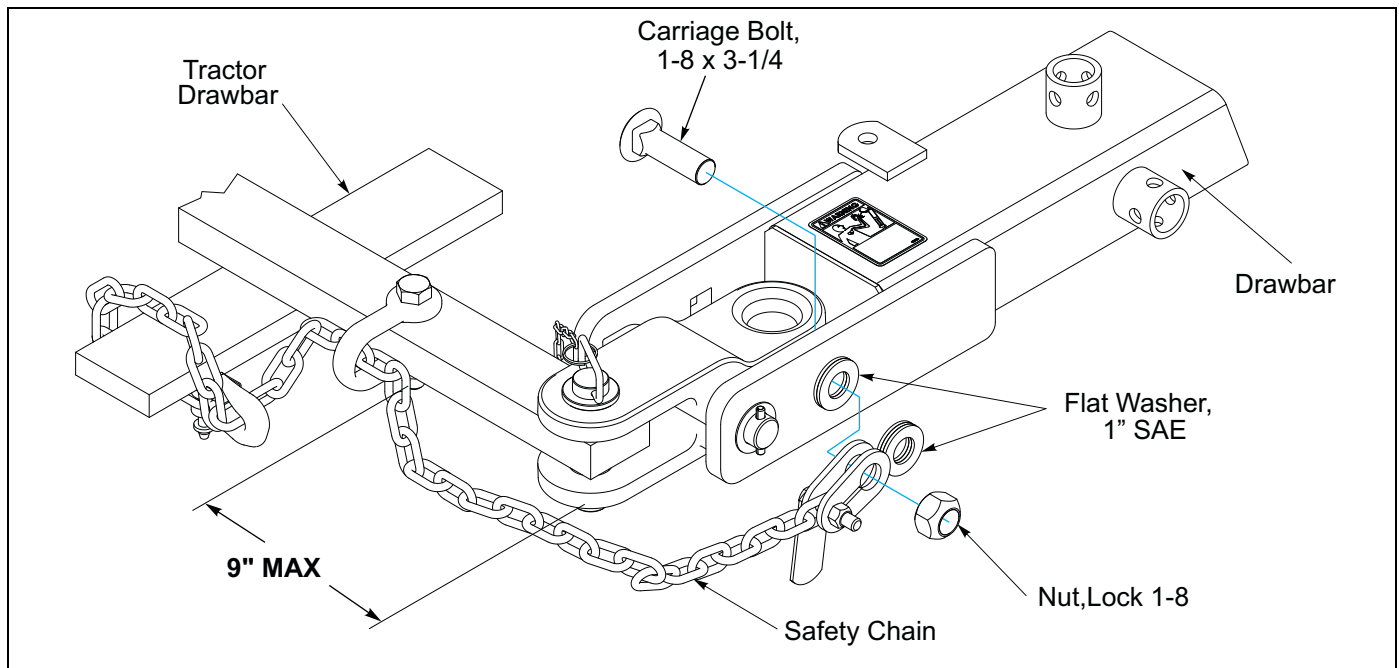

Figure 1-2: Safety Chain

Decals

OK HERE (TRANSPORT LOCK HOLES)

OK HERE (ANY HOLE FORWARD OF ANGLE BRACKETS)

NEVER HERE. (HOLES REARWARD OF ANGLE BRACKETS)

IMPORTANT
EXCEPT IN TRANSPORT LOCK HOLE, DO NOT INSTALL PINS REARWARD OF ANGLE BRACKETS. DOING SO WILL RESULT IN DAMAGE TO MACHINE WHEN CYLINDER IS EXTENDED.

9J257

9J257

WARNING

DO NOT GO NEAR LEAKS
High pressure oil easily punctures skin causing serious injury, gangrene or death. If injured, seek emergency medical help. Immediate surgery is required to remove oil. Do not use fingers or skin to check for leaks. Lower load or relieve hydraulic pressure before loosening fittings.

10813A

3K706

CAUTION

MOVING MACHINES CAN CAUSE INJURY. KEEP AWAY!

1. KEEP AWAY FROM MOVING TRACTORS OR IMPLEMENTS. KEEP OTHERS AWAY.
2. DO NOT RIDE OR ALLOW OTHERS TO RIDE ON TRACTOR OR IMPLEMENT.
3. BLOCK IMPLEMENT TO PREVENT MOVEMENT WHEN UNHITCHED FROM TRACTOR.
4. KEEP ALL GUARDS AND SHIELDS IN PLACE WHILE MACHINE OR PARTS ARE IN MOTION.

8J309

8J309



4K036
4K039



528933

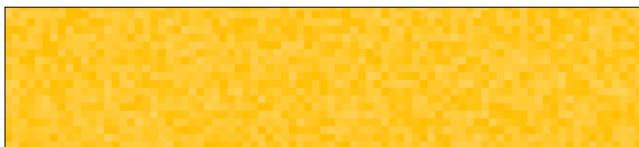

528934

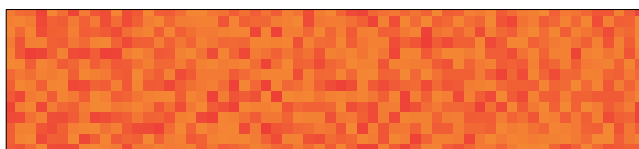

528938

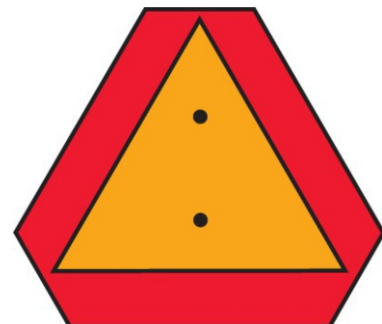

2P151

Figure 1-3: Decals

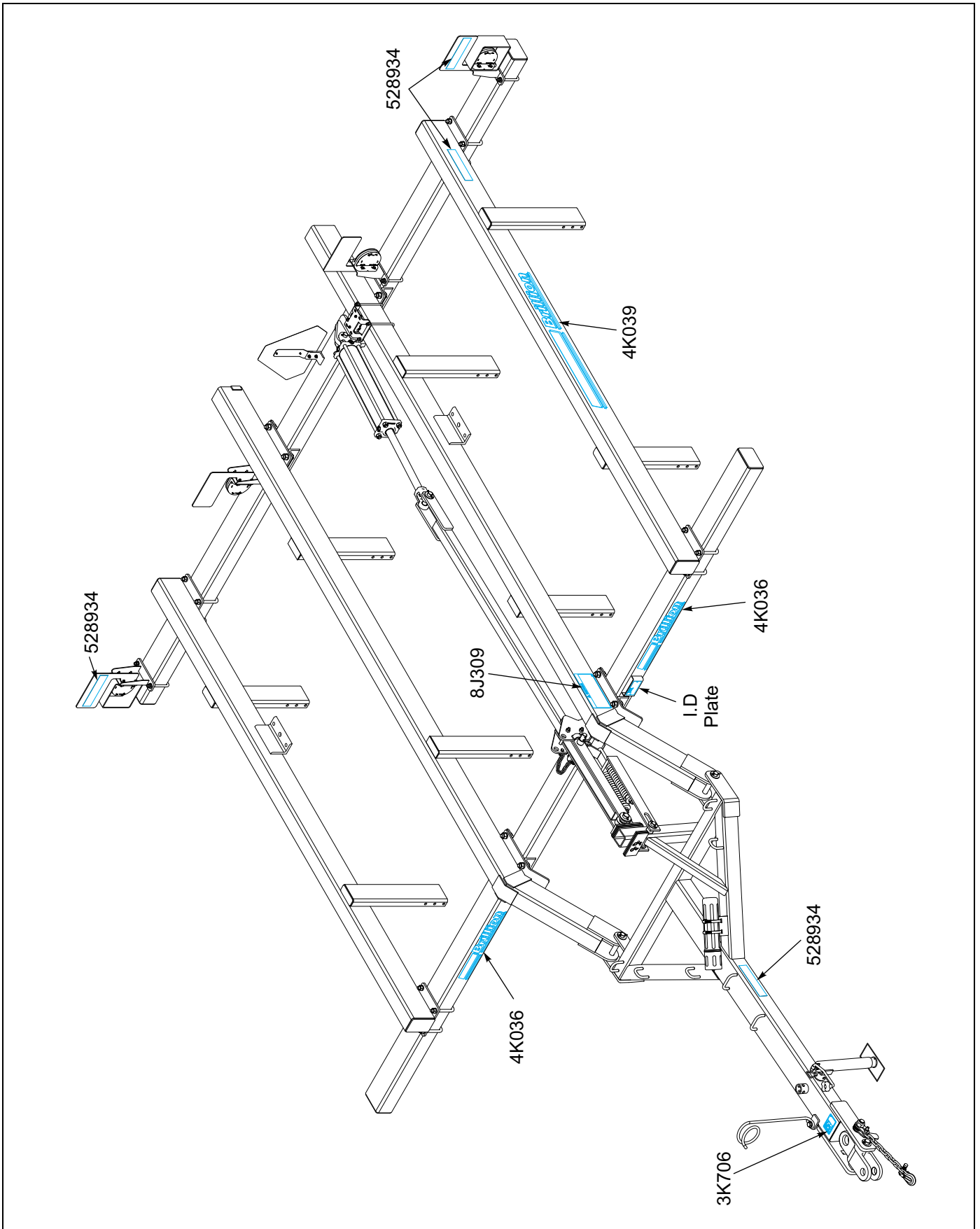

Figure 1-4: Decal Placement (1 of 3)

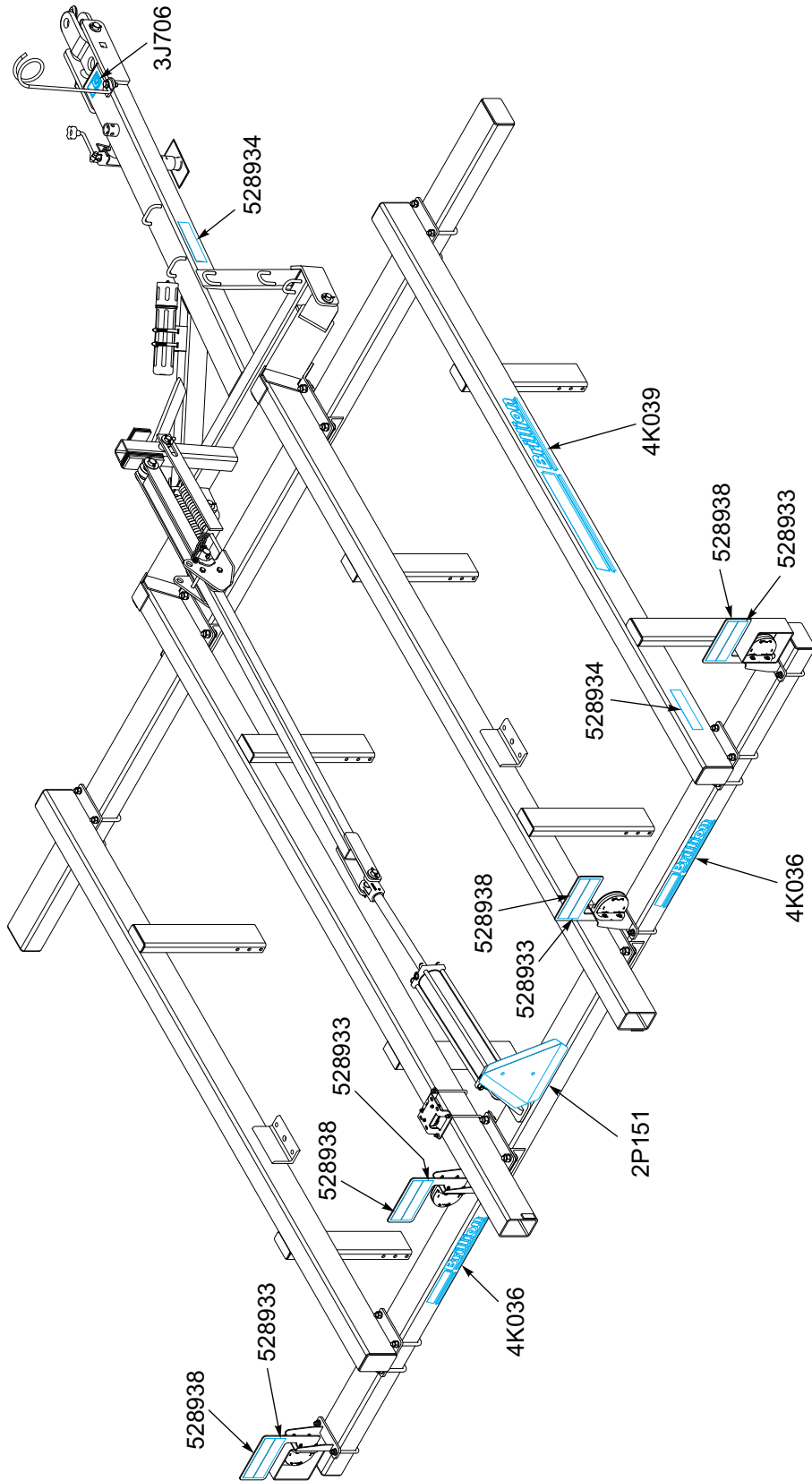

Figure 1-5: Decal Placement (2 of 3)

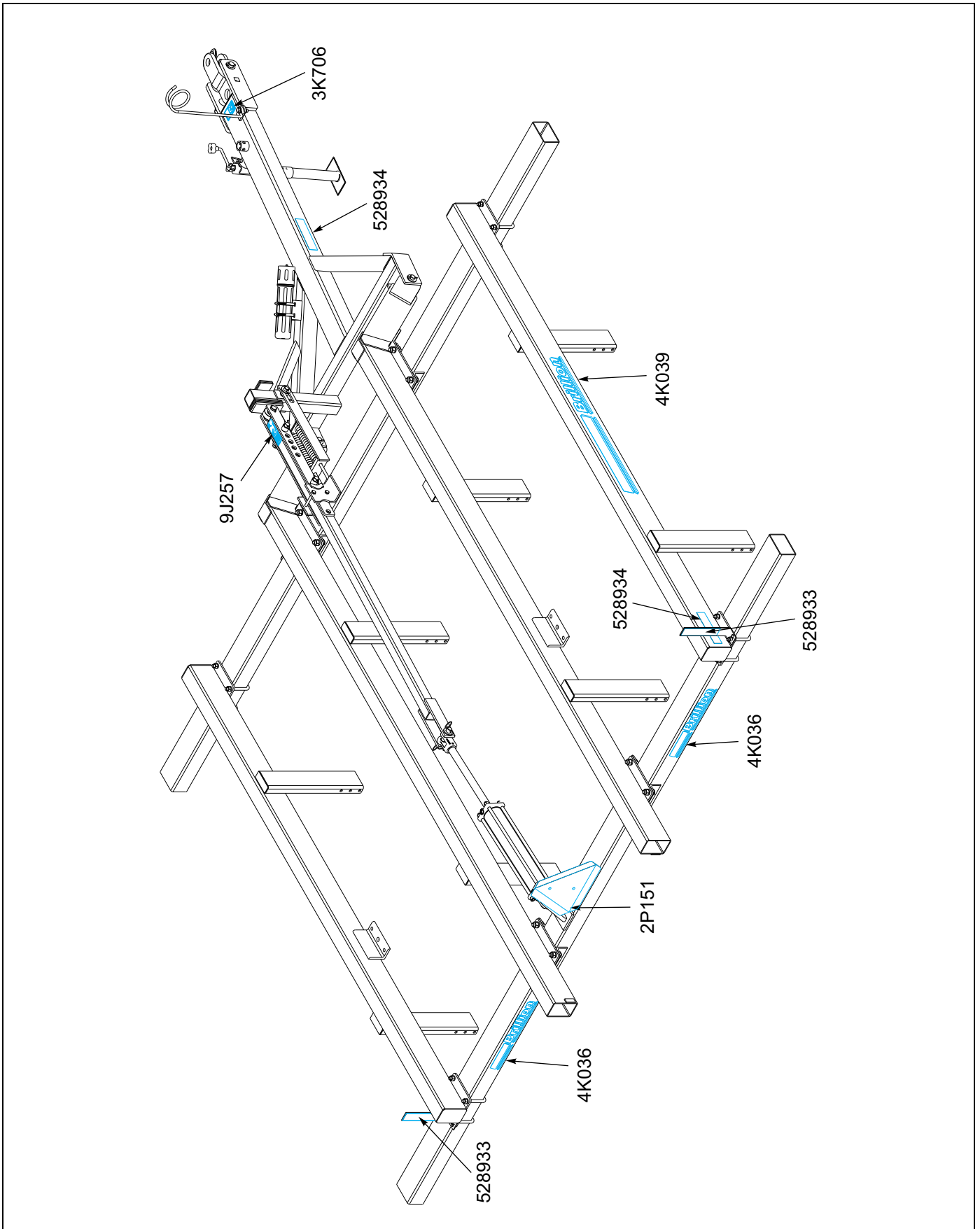

Figure 1-6: Decal Placement (3 of 3) - Prior to July 2016



CAUTION

Do not work on or under this machine unless securely blocked and supported by a hoist or tractor or by other sufficient means.

The intent of this chapter is to provide instruction, allowing you to safely and correctly assemble your Brillion product.

NOTE

The machine shown in the following illustrations may not agree with the size of your unit. Assembly of machines, however, is similar on all models. Additional parts identification and location can be obtained by reviewing parts manual 1K975.

NOTE

“Left” and “Right” refer to directions seen as if standing behind the machine and facing in the direction of forward travel.

IMPORTANT

- If pre-assembled parts or fasteners are temporarily removed, remember where they go. It is best to keep the parts separated.
- Check that all working parts move freely, bolts are tight and cotter pins are spread.

Refer to the Torque Table for proper bolt torque values. Note the different torque requirement for bolts with lock nuts. See **“General Torque Specifications” on page 4-1.**

Frame Assembly

1. Place Front and Rear Frame Tubes on supports spaced 10 feet apart. Ensure supports are rated at 2,000lbs each.
2. Position Inner Frame Tubes. Fasten Inner Frame Tubes to Front and Rear Tubes with 3/4-10 X 2 Bolts, Lockwashers and Nuts. Ensure that the Inner Frame Tubes are square with the Front and Rear Frame Tubes. **See Figures 2-1 and 2-2.**
3. Position Outer Frame Tubes. Fasten with 5/8-11 U-Bolts, Lockwashers and Nuts. **See Figures 2-1 and 2-2.**
4. Install the Relief Valve Bracket. Fasten with 5/8-11 U-Bolts, Lockwashers and Nuts.
5. Install the SMV sign using two 5/16-18 x 1 Bolts, Washers, and Locknuts.
6. Tighten all hardware to the recommended torques. **See Page 4-1.**

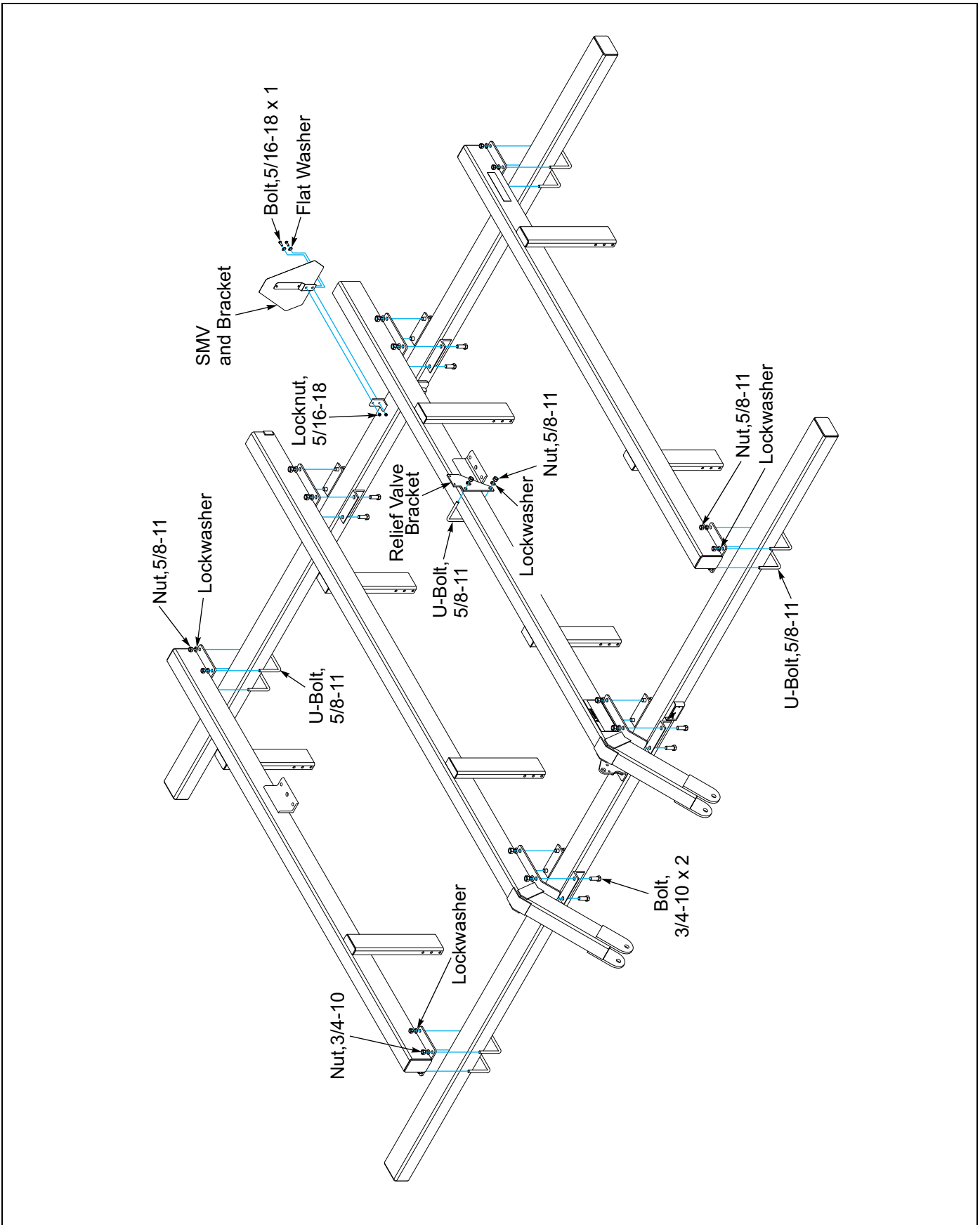

Figure 2-1: Frame Assembly

Frame Assembly Dimensions

"Left" and "Right" refer to directions seen as if standing behind the machine and facing in the direction of forward travel.

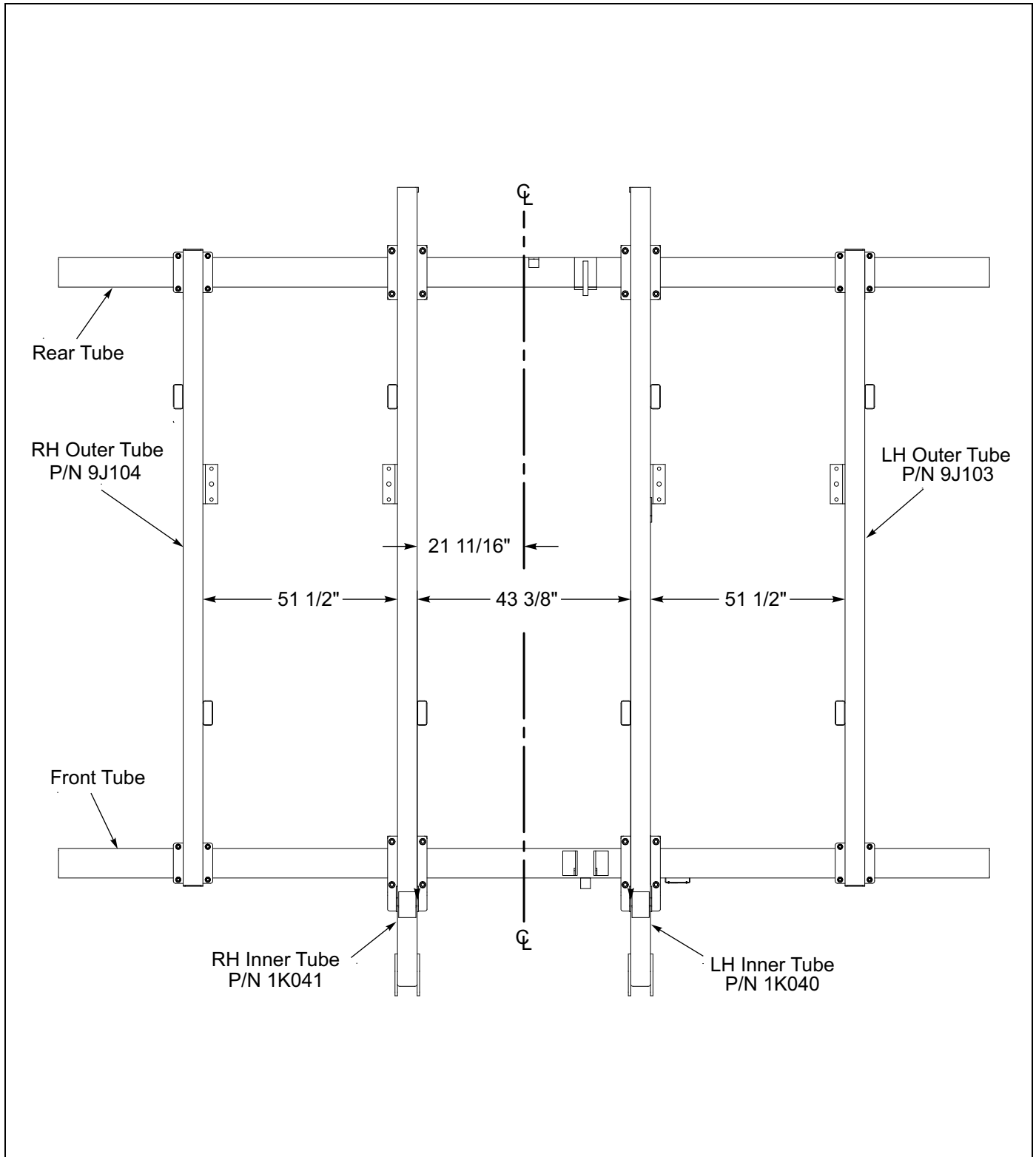

Figure 2-2: Frame Assembly Dimensions

Rockshaft Installation

Place the Rockshaft under the frame rockshaft mounting angles.

1. Coat the bearing surface of the Bearing Assemblies with grease before fastening Rockshaft to Frame with 5/8-11 x 7 Bolts, Lockwashers and Nuts.

2. Install the base end of the 3 1/2 x 16 Hydraulic Cylinder with ports up to the Rear Frame Lug and the Rod End to the Rockshaft Arm with the pins provided **See Figure 2-5.**
3. Mount a Wheel and Tire Assembly onto each hub with 1/2-20 x 1" Wheel Bolts. **Torque to 80-85 Ft/Lbs.**
4. Tighten all hardware to the recommended torques. **See Page 4-1.**

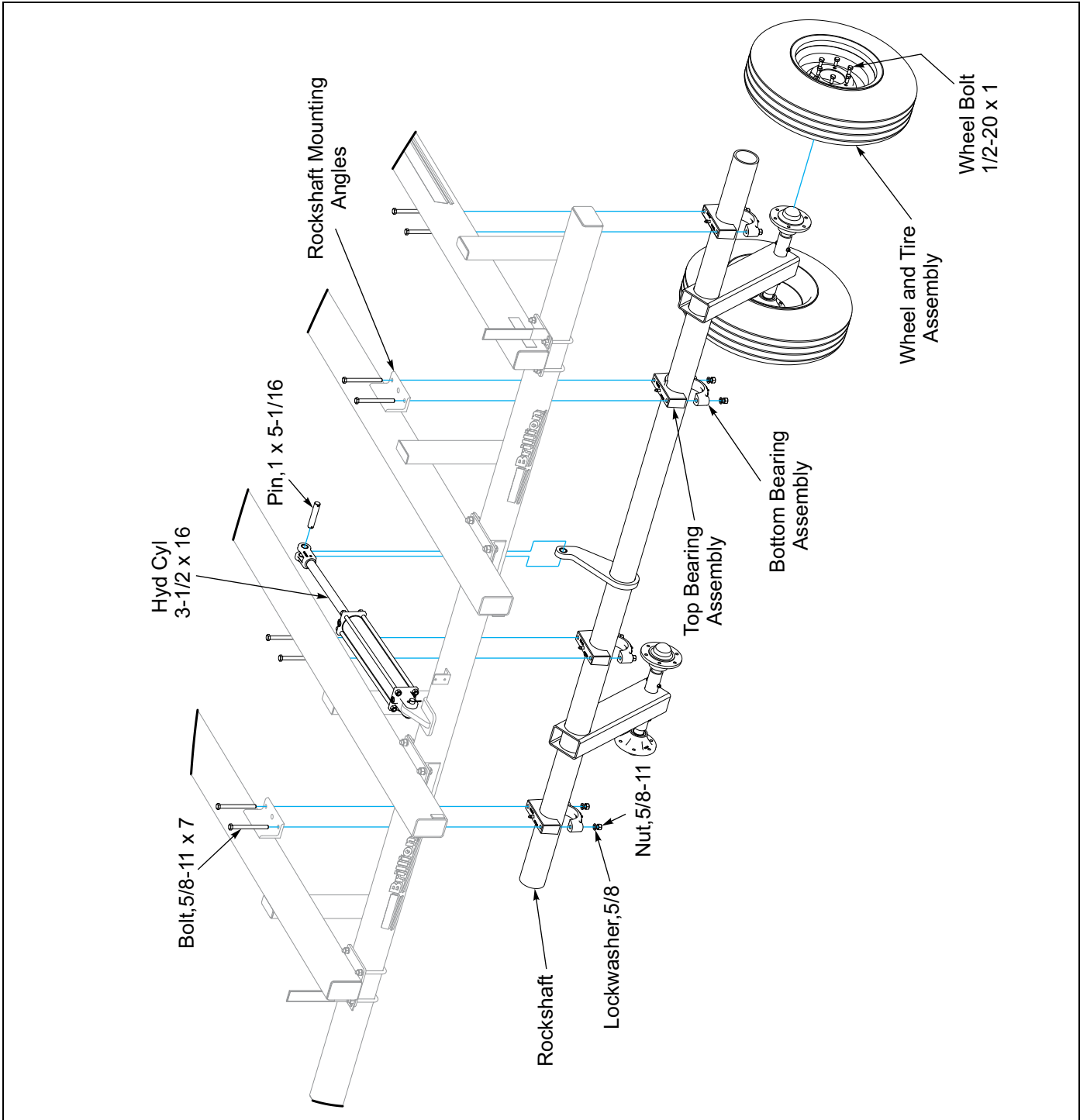

Figure 2-3: Rockshaft

Transport Axle Link Installation

On the front frame tube angle bottom hole, install Spacer (.546 x .84 x 3) using a 1/2-13 x 5 Bolt and Locknut. Do not over tighten, Spacer must be free to rotate. **See Figure 2-4.**

Position Link to the front of the machine on top of the installed Spacer (.546 x .84 x 3). To contain the Link, insert in the top hole of the front frame tube angle a 1/2-13 x 5 Bolt and Locknut. Do not over tighten, Link must be free to pass between the Spacer and Bolt.

Insert the Transport Link Pin into the top hole of the front frame tube angles. Place spacer (1.031 x 1.375 x 1.063) on Transport Link Pin and secure with Hair Pin Cotter. Insert 3/8-16 x 1-1/4 bolt into Frame Tube Angle, place one end of chain on end of bolt and secure with Flanged Locknut. Insert 3/8-16 x 2-1/4 bolt into Transport Link Pin, place other end of chain on end of bolt and secure with Flanged Locknut.

In the front hole of the Link, install Roller Assembly with a Spacer (1.375 x 1.66 x .688) on each side, place Thrust Washer on the outside of Link. Secure with Pin (1-1/4 x 4-1/2) and 1/4 x 2 Roll Pins. Place a Spacer on each side of the Link, secure with Roll Pin and a Hairpin Cotter.

Align the Link single rear hole up with the Rockshaft Arm. Place a 1" Narrow Flat Washer on each side between the Rockshaft Arm and the Link and one on the outside of the Link, secure with 1 x 5-1/16 Pin and 1/4 x 2 Roll Pins. **See Figure 2-5.**

NOTE

*The Transport Lock is now in the Storage position. Refer to **Figure 3-2** to put the Transport Lock Pin in the lock position.*

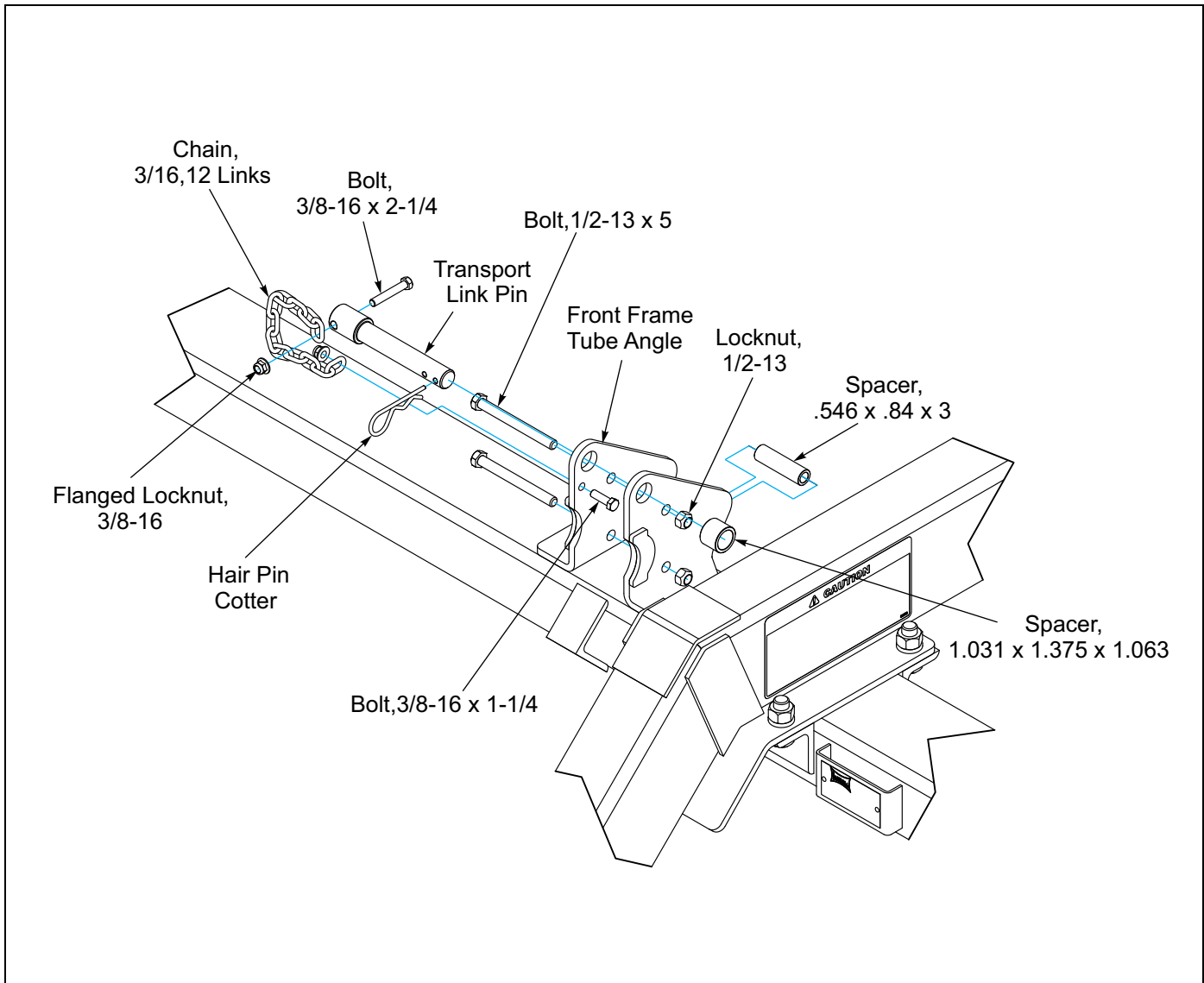

Figure 2-4: Transport Link Pin Installation

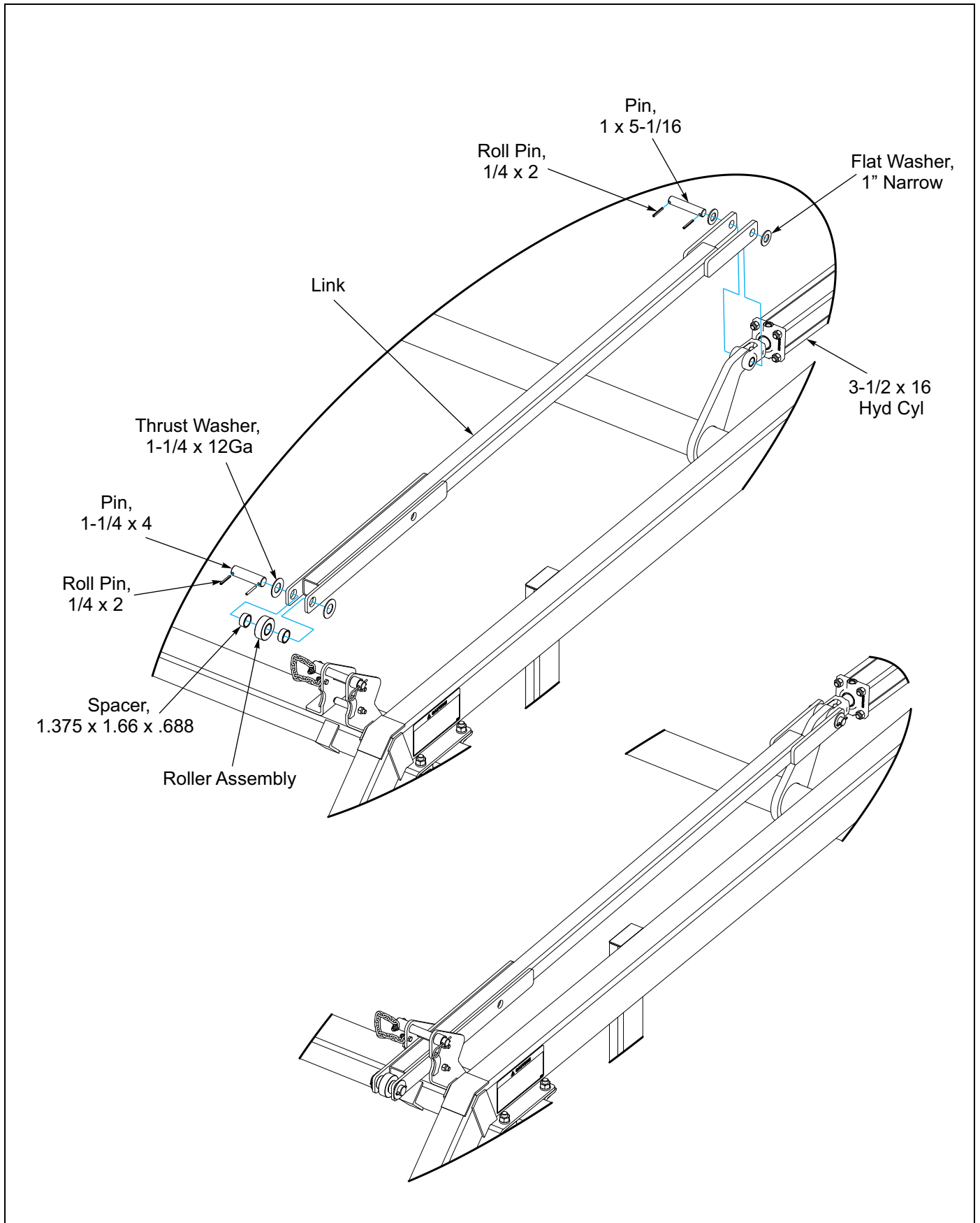

Figure 2-5: Transport Axle Link

Drawbar Installation

1. Attach Drawbar to the Frame using two 1 X 7 7/16 Pins, Flat Washers and 1/4 X 1 1/2 Cotter Pins. See **Figure 2-6**.
2. Attach Safety Chain with 1-8 X 3 1/4 Carriage Bolt, Flat Washers and Lock Nut.
3. Attach the Hose Support with 5/8-11 X 2 Bolt, Flat Washer and Lock Nut.
4. Install Jack.
5. Attach the Hitch with 1 1/4 X 8 3/4 Pin and 5/16 X 2 Roll Pins and Washers.
6. Mount the Manual Storage Canister to the Drawbar Mount with two Hose Clamps.

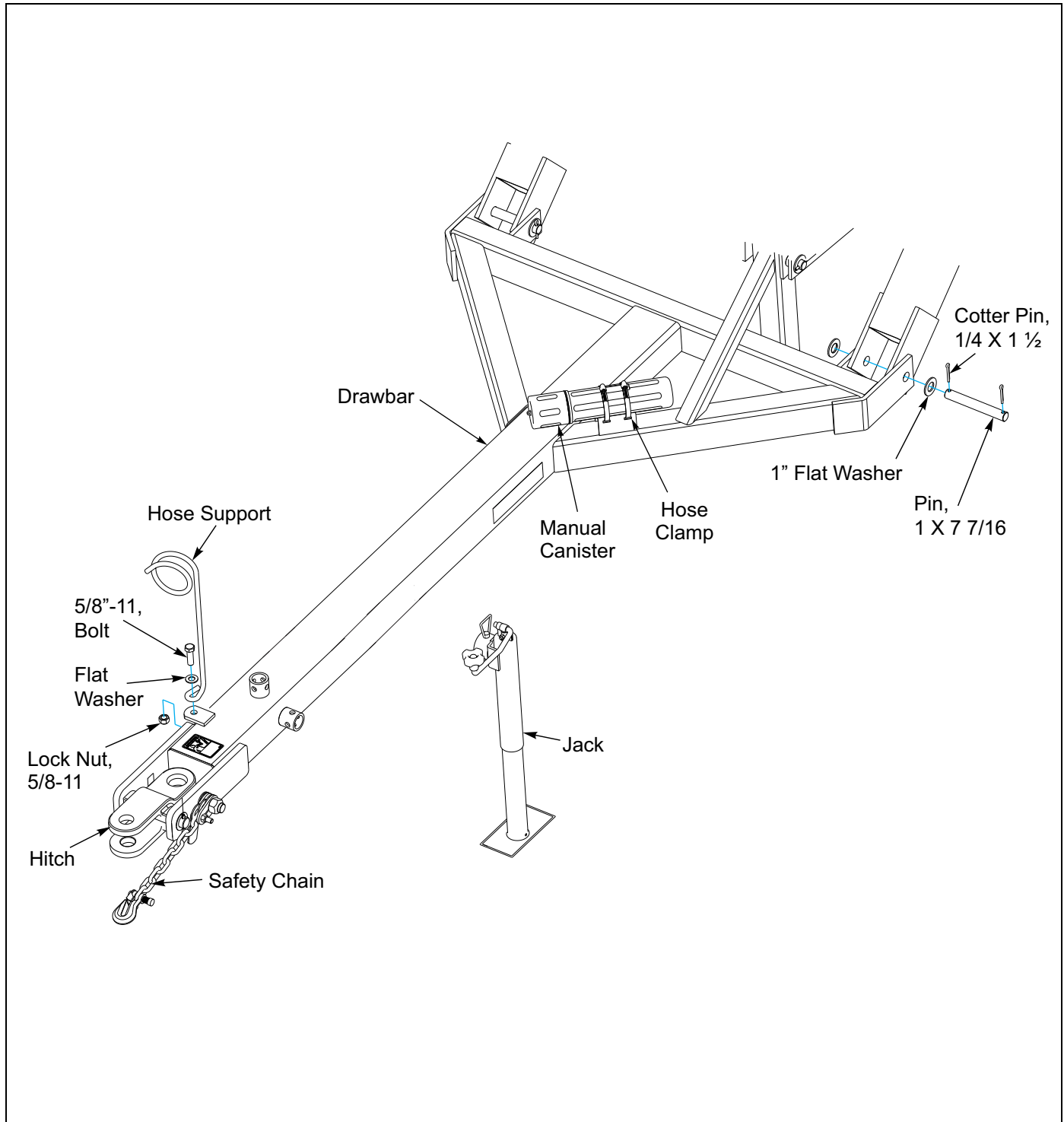

Figure 2-6: Drawbar, Hitch and Safety Chain Installation

Spring Linkage Assembly

Install the Spring Linkage between the front Frame Tube and the Drawbar. Slip 5/8-11 x 2-3/4 x 16 U-bolt around the angle on the front frame tube. Slide onto the U-bolt the Spring Linkage, two Spring Caps with flat surface against Spring Linkage Plate, two springs, two more spring caps with flat surface facing away from the spring, and 5/8-11 Lock Nuts. Tighten the Lock Nut until about 3/8" of thread is sticking out past the nut. This will need to be adjusted after the hydraulic system is hooked up. *The purpose of the spring linkage is to cause the rear of the machine to lift before the front during the raising cycle. Tighten the Lock Nut if the front of the machine raises before the rear.*

Align Spring Linkage slot with Drawbar Center Mast. On the Center Mast place a flat washer on each side of the Spring Linkage slot. Secure with Cylinder Pin (1 x 7-1/2) and 1/4 x 2 Roll Pin.

Install the Bumper and Spacers at the top of the Drawbar Center Mast with Hairpin Cotters. Shown are three Spacers on the front of the Drawbar Center Mast and three Spacers on the Rear of the Drawbar Center Mast, it may be necessary to adjust the spacer quantity between the bumper and the drawbar vertical tube if the front of the machine needs to be higher for transport.

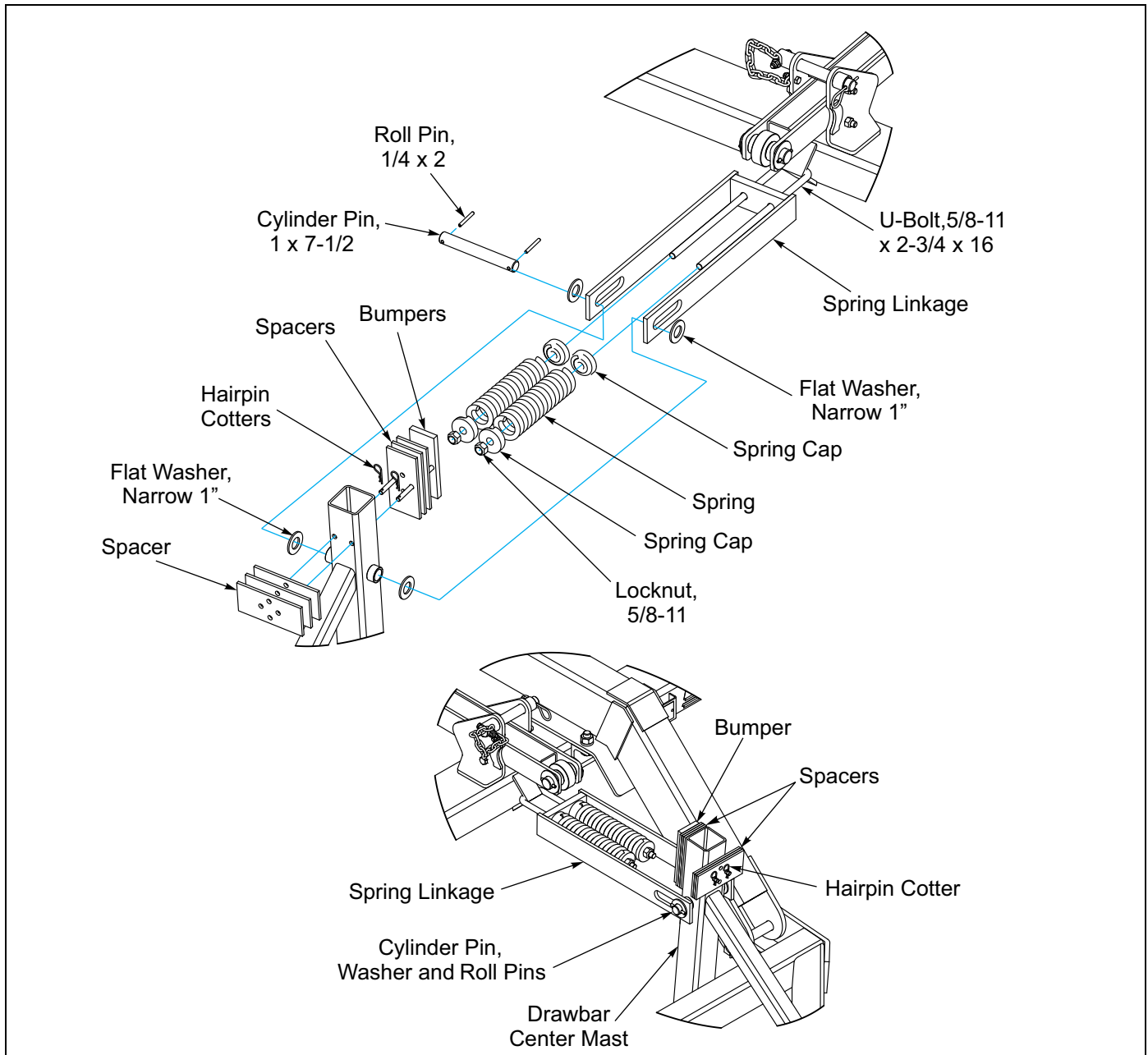

Figure 2-7: Spring Linkage Installation

Roller Installation

Determine Roller Assemblies location based on the machine model. **See Figure 2-10.**

NOTE

Clamp end of the Roller Assemblies must be to the outer extremity of the center frame so adjustments can be made easily when needed.

NOTE

Crowfoot Wheel Rotation Arrow must follow the direction of travel.

ML and MLS

Notched Wheels front and rear.

MCL and MCLS

Crowfoot Wheels front and Notched Wheels rear.

MLC and MLCS

Notched Wheels front and Crowfoot Wheels rear.

MCC and MCCS

Crowfoot Wheels front and rear.



WARNING

Do Not Work Under Machine Unless It Is Blocked Securely

Center Bracket Assembly has a bearing on each side.

End Bracket Assembly has a bearing on one side

Mount a Center Bracket Assemblies on the front Frame Tube with 3/4-10 x 6-13/16 x 5-3/4 U-Bolts, Lockwashers and Nuts. **See Figure 2-8.**

Slide a Roller Assembly between the Center Bracket Assemblies so that the Roller stub shaft is against the Bracket bearing.

Slide a Left and Right front Roller Assembly into each side of the Center Bracket Assembly so that the Roller stub shaft is against the Bracket bearing. **See Figure 2-9.**

Install an End Bracket Assembly onto the end of each Roller Assembly so that the Roller stub shaft is against the Bracket bearing. Attach with 3/4-10 x 6-13/16 x 5-3/4 U-Bolts, Lockwashers and Nuts.

On the Rear Frame Tube mount a Center Bracket Assemblies with 3/4-10 x 6-13/16 x 5-3/4 U-Bolts, Lockwashers and Nuts. **See Figure 2-8.**

Slide the longer Roller Assembly into the left side of the Center Bracket Assembly and the other Roller Assembly into the right side.

Install an End Bracket Assembly onto the end of each Roller Assembly so that the Roller stub shaft is against the Bracket bearing. Attach with 3/4-10 x 6-13/16 x 5-3/4 U-Bolts, Lockwashers and Nuts. **See Figure 2-9.**

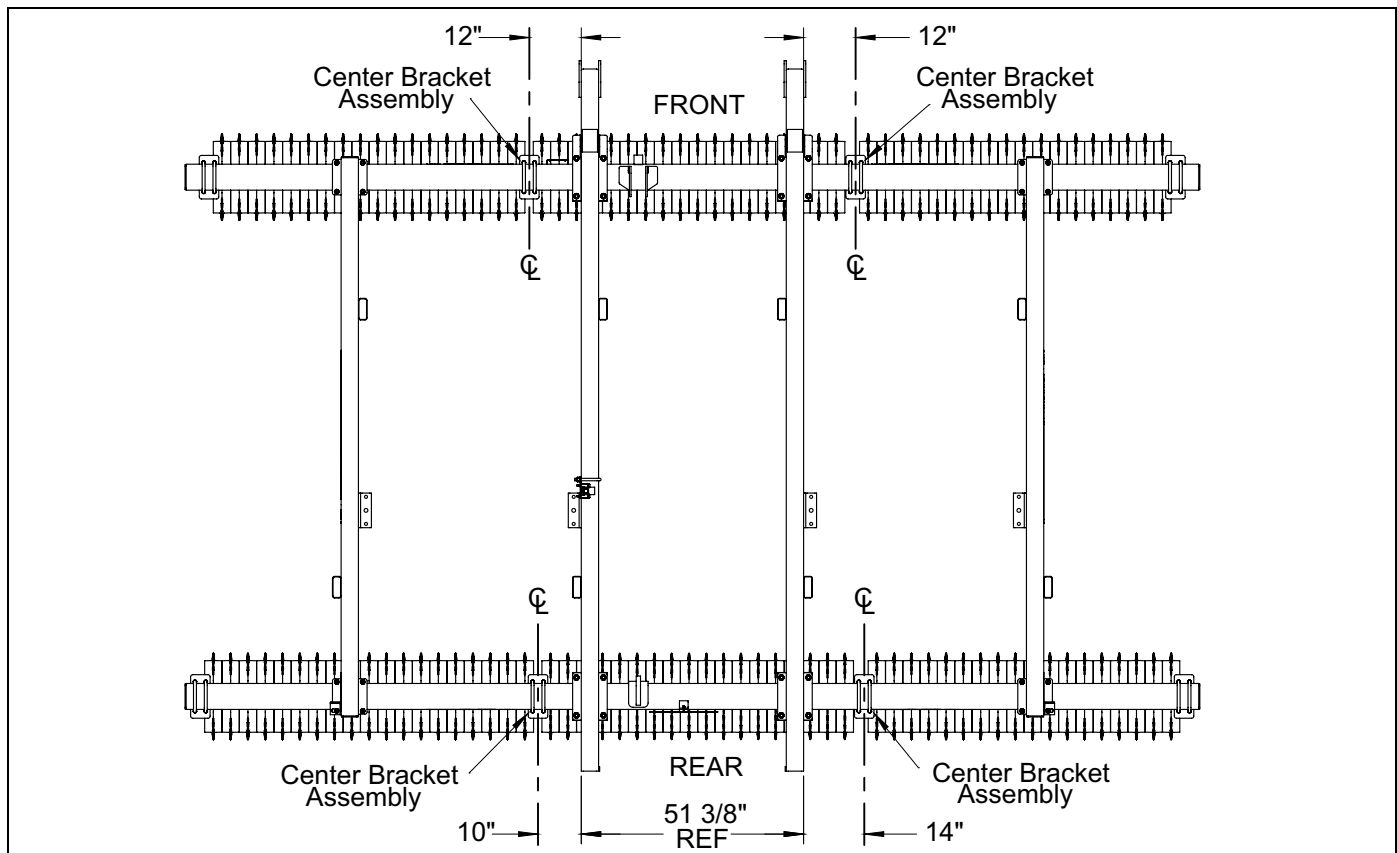

Figure 2-8: Center Bracket Mounting Dimensions

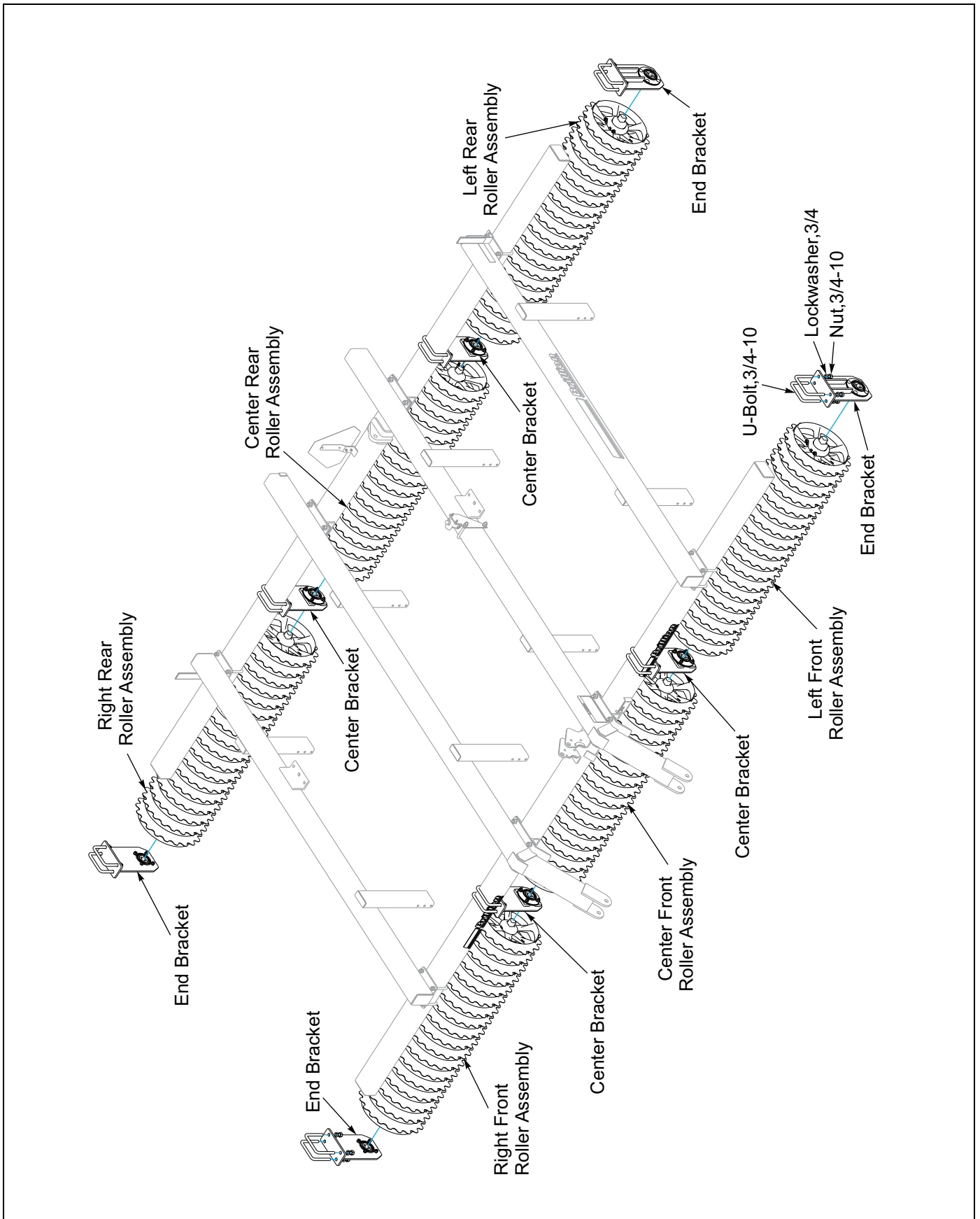

Figure 2-9: Roller Installation

Roller Combinations						
Model	A	B	C	D - Long	E	F
ML2253 MLS2253	9J523	9J523	9J523	9J522	9J523	9J523
MCL2253 MCLS2253	9J832	9J833	9J833	9J522	9J523	9J523
MLC2253 MLCS2253	9J523	9J523	9J523	9J830	9J832	9J833
MCC2253 MCCS2253	9J832	9J833	9J833	9J830	9J832	9J833

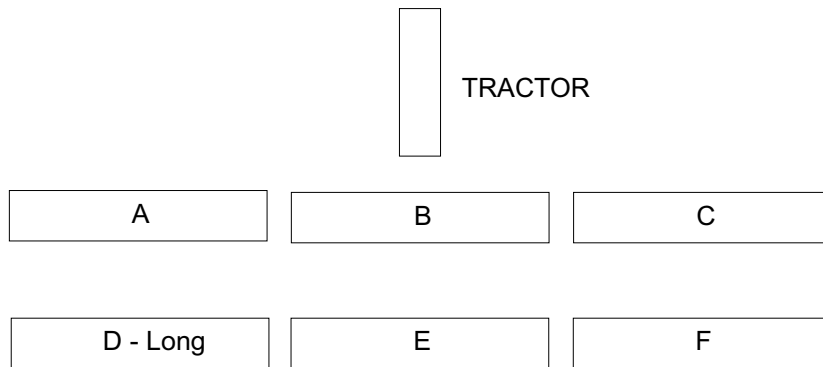

Figure 2-10: Roller Assemblies

Bracket Assembly

Assemble Tooth Tube Brackets to Center Frame Vertical Tubes. **See Figures 2-11 and 2-12.** Reversing some of these brackets will cause interference later when mounting the teeth.

C-Tooth Machines

Assemble a 9J090 Tooth Tube Bracket to the front of each Front and Rear Vertical Center Frame Tube Support middle and bottom holes using 1/2-13 x 6 Bolts and Locknuts. **See Figure 2-11.**

S-Tine Machines

Assemble a 9J091 Tooth Tube Bracket to the front of each Front and Rear Vertical Center Frame Tube Support top and middle holes using 1/2-13 x 6 Bolts and Locknuts. **See Figure 2-12.**

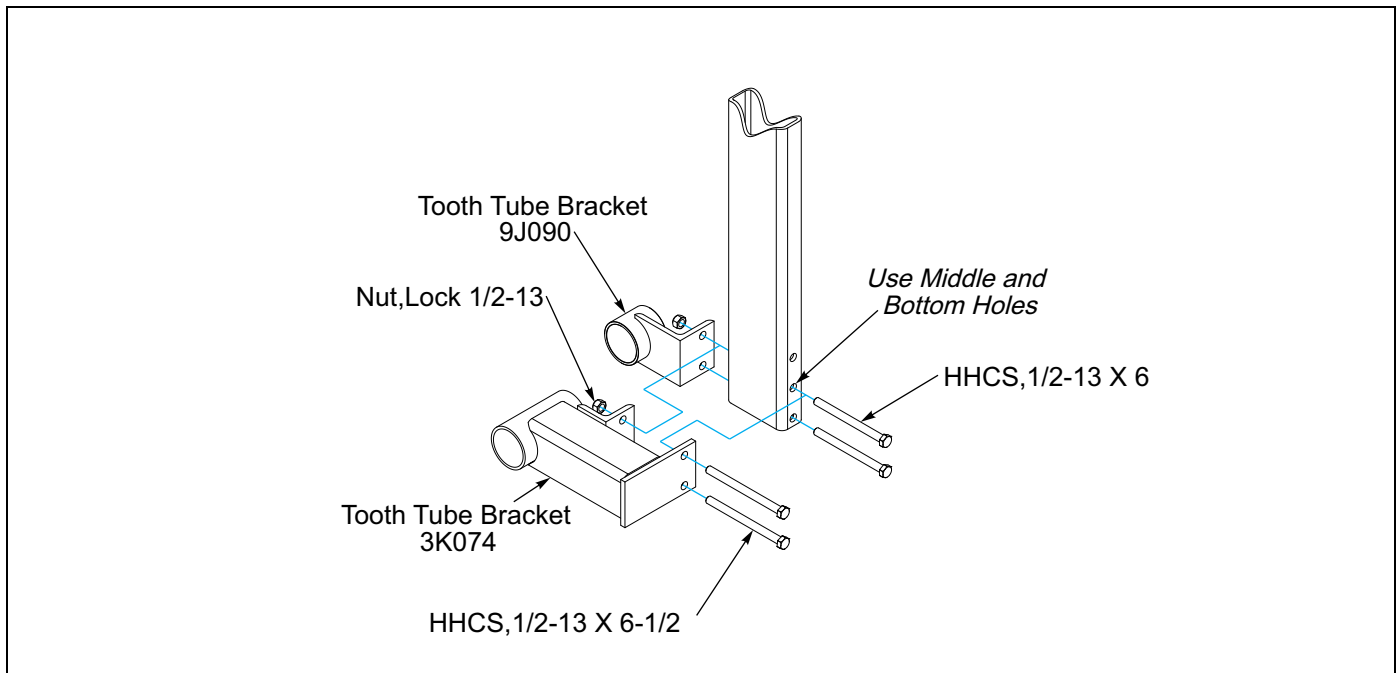

Figure 2-11: C - Tooth Bracket Assembly

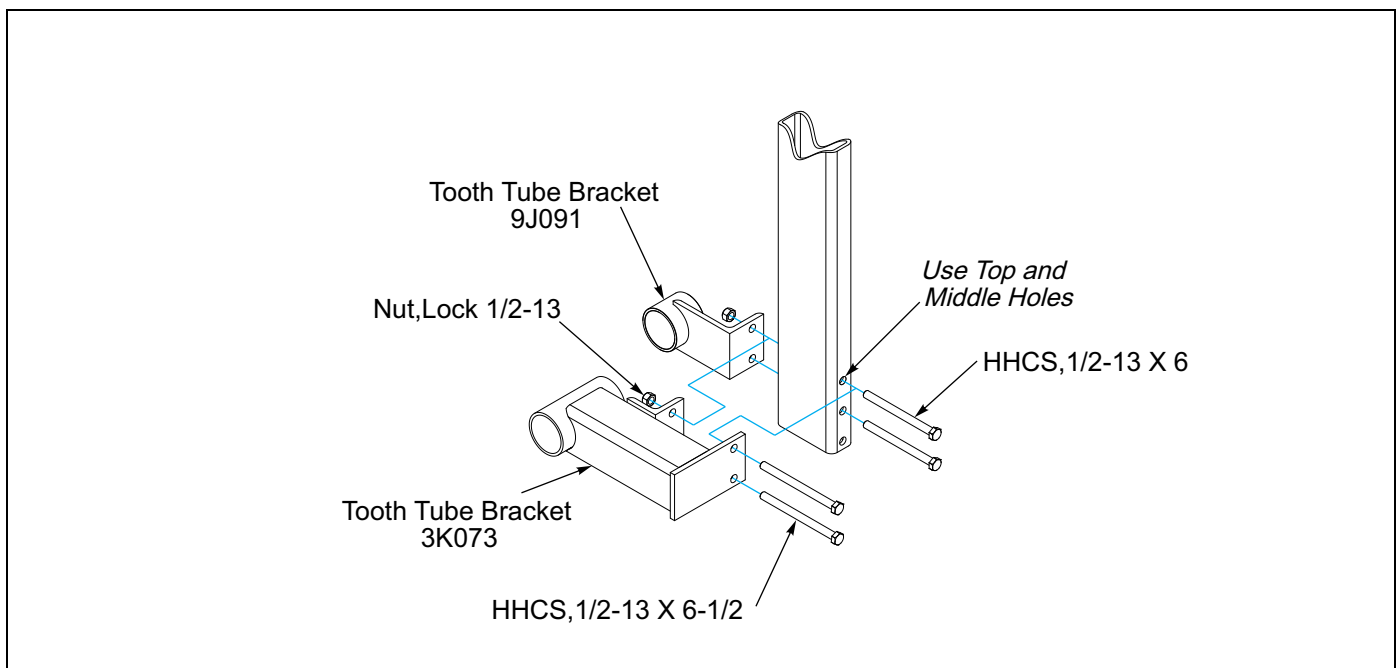

Figure 2-12: S - Tine Bracket Assembly

Tooth Tube Bracket Locations

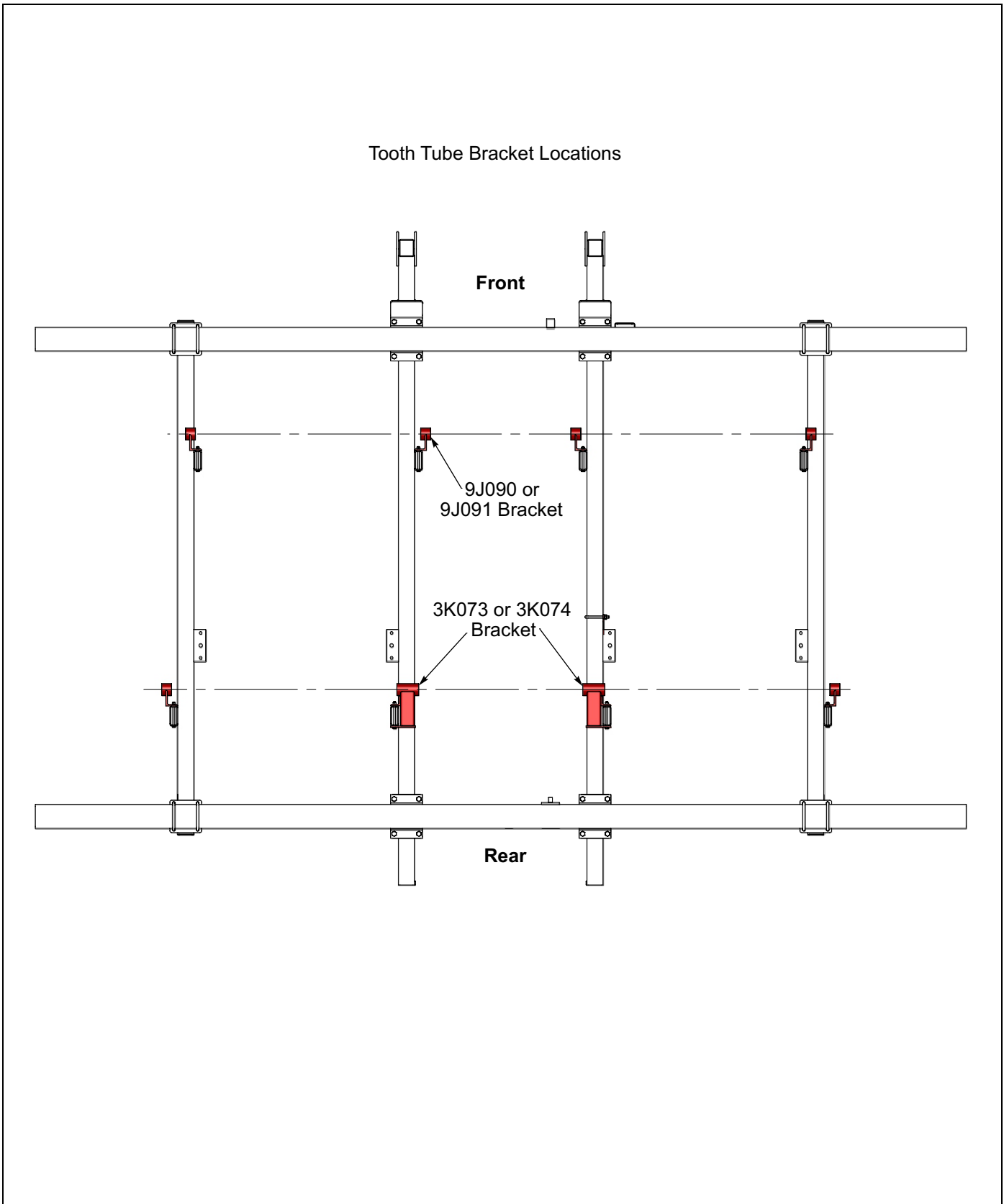

Figure 2-13: Tooth Tube Bracket Locations

Tooth Control Installation

After you have all eight brackets assembled, pencil mark the tooth locations on the tooth tubes. **See Figure 2-18.** Slide the tooth tubes through the brackets. Both of the tooth tubes must be centered on the machine - an equal length of tube extending out beyond the outer brackets. Slide each tooth up against the tooth tube bracket, this helps prevent the tube from sliding. Then fix the tubes in place by assembling straps and securing with 1/2-13 x 2-5/8 x 3-1/4 U-bolt, Lockwashers and Nuts to each tooth tube. Locate them on the outside of the inner tooth tube brackets. **See Figure 2-14.**

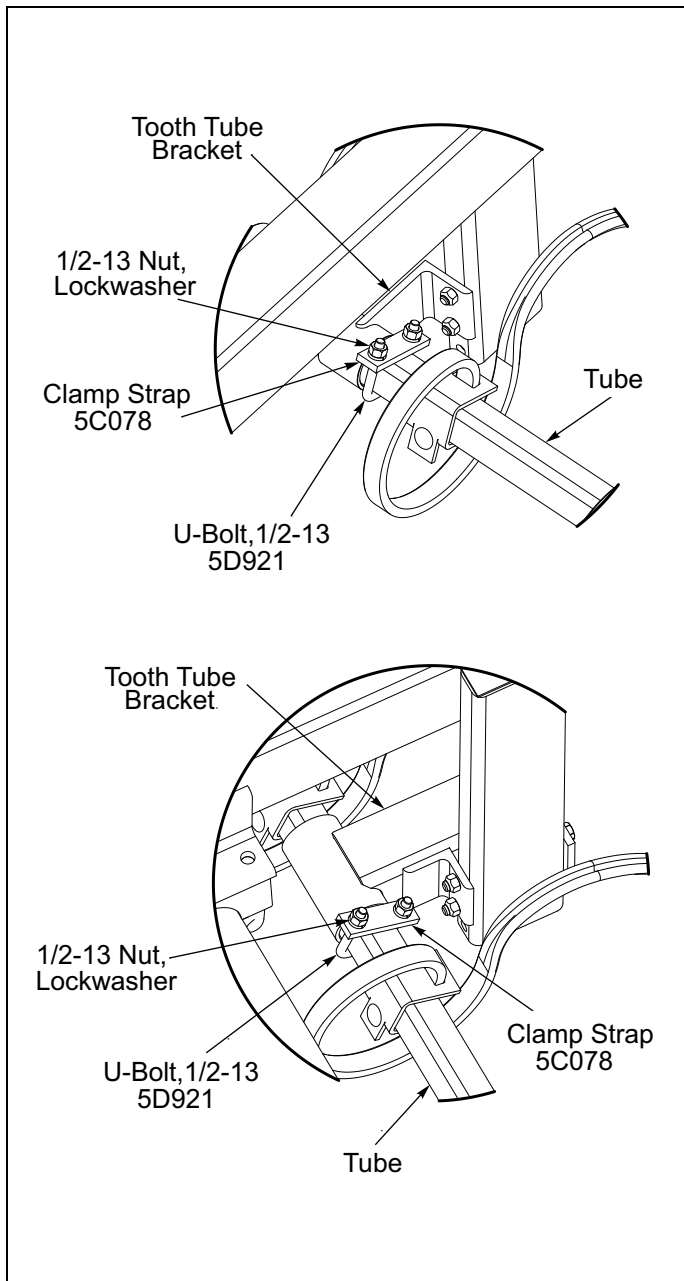

Figure 2-14: Fixing the Tubes in Place

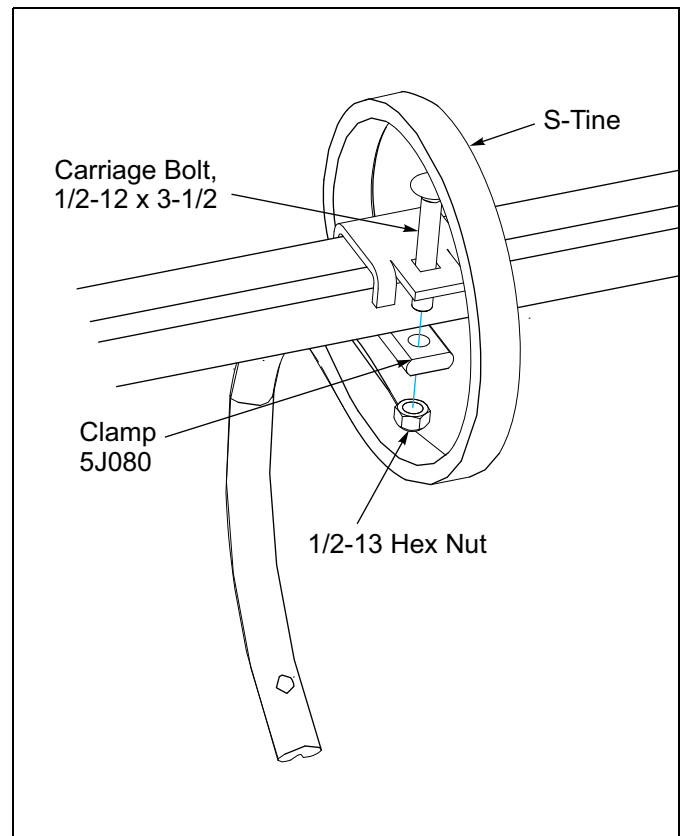

Figure 2-15: S-Tine

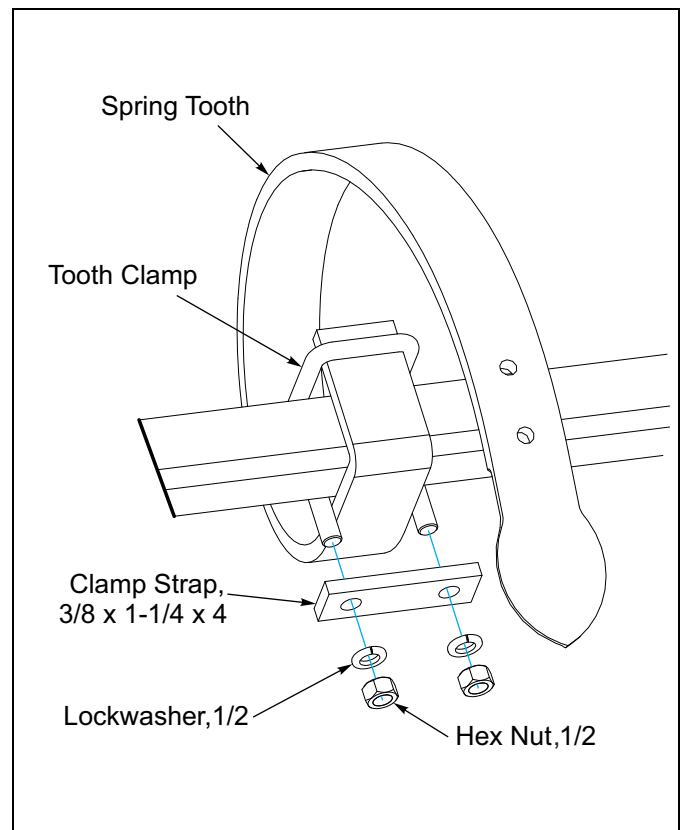

Figure 2-16: C-Tooth

S-Tine Installation

Tooth locations are shown in **Figure 2-18**. For ease of installation, assemble points with 3/8-16 x 1-3/4 Plow Bolts and Flange Locknuts to spring tine before mounting onto tooth tube. **See Figure 2-17**. Secure each with a Clamp, 1/2-13 x 3-1/2 Carriage Bolt and Locknut. **See Figure 2-15**.

Locate on the front Tooth Tube the S-Tine that is right of center. On both sides of the S-Tine, mount S-Tine RH Angle and S-Tine LH Angle on the same side of the Tooth Tube as the S-Tine Clamp. Attach Angles to the Tooth Tube with 5/8-11 x 2-5/8 x 3-1/4 U-Bolt, Lockwashers and Nuts. Do Not Tighten. **See Figure 2-20**.

Take the Linkage end with the 2 holes and align the first hole with the S-Tine RH Angle and S-Tine LH Angle. Place Spacer between the Linkage holes and insert 3/4 x 6-5/16 Pin. Add 3/4 Flat Washer onto each side of the Pin. Secure with 3/16 x 1-1/2 Cotter Pins. Center the Linkage between the S-Tine. Tighten RH Angle and LH Angle mounting hardware.

Run the Linkage back to the rear Tooth Tube. Install the Tooth Control Bracket, with the lug towards the rear, onto the rear of the rear Tooth Tube perpendicular to the S-Tine Clamp. Secure Bracket to Tooth Tube with 5/8-11 x 2-5/8 x 3-3/8 U-Bolt, Lockwashers and Nuts. Align Bracket Sleeve with Link Hole and insert 3/4 x 5-5/16 Pin. Add 3/4 Flat Washer on each side of the Pin. Secure with 3/16 x 1-1/2 Cotter Pin. **See Figure 2-20**.

Manually check the Linkage to ensure there is no binding and no interferences with the Tines when Tooth Tubes are rotated.

Install the Cylinder Bracket to the front of the Rear Frame Tube aligning the Cylinder Bracket Lug with the rear Tooth Control Bracket Lug. Attach Cylinder Bracket to Rear Frame Tube with 4-Hole Plate, 5/8-11 x 8 Bolts, Lockwasher and Nuts.

Attach 3 x 8 Hydraulic Cylinder base end to the Cylinder Bracket Lug and the rod end of the Cylinder to the Tooth Control Bracket Lug with the Pins provided.

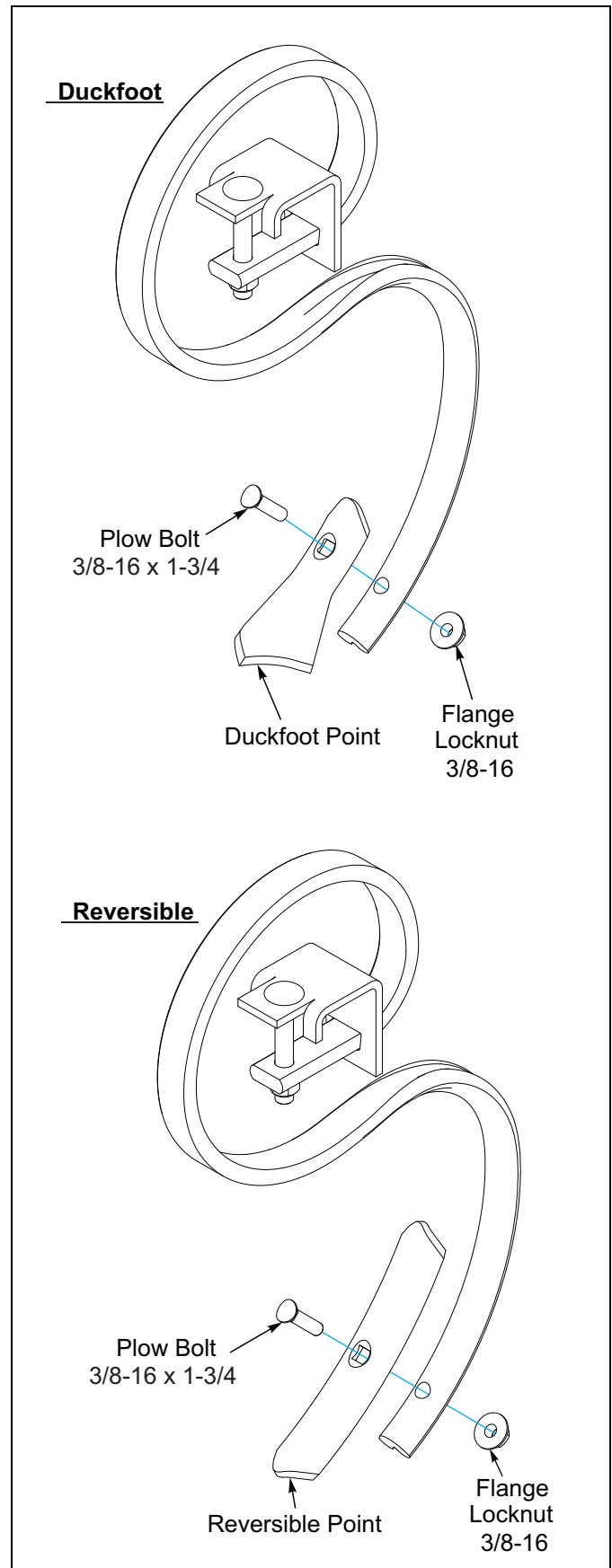

Figure 2-17: S-Tine Points

C-Tooth Installation

Tooth locations are shown in **Figure 2-18** Secure each with a Tooth Clamp, a Clamp Strap, Lockwashers and Nuts. **See Figure 2-16.**

Locate on the front Tooth Tube the C-Tooth that is right of center. On the front of the Tooth Tube perpendicular to the C-Tooth Clamp Strap, install a C-Tooth Front Bracket on both sides of the C-Tooth. Attach with 5/8-11 x 2-5/8 x 3-3/8 U-Bolt, Lockwashers and Nuts. Do Not Tighten.

See Figure 2-19.

Place a 3/4" Flat Washer onto each C-Tooth Front Bracket Shaft. Take the Linkage end with the 2 holes and slide the first hole over the shaft of each Front Bracket. Secure Linkage with 3/16 x 1-1/2 Cotter Pins. Center the Linkage between the C-Tooth. Tighten Front Brackets mounting hardware.

Run the Linkage back to the rear Tooth Tube. Install the Tooth Control Bracket, with the lug towards the rear, onto the front of the rear Tooth Tube perpendicular to the C-Tooth Clamp Strap. Secure Brackets to Tooth Tube with 5/8-11 x 2-5/8 x 3-3/8 U-Bolt, Lockwashers and Nuts. Align Bracket Sleeve with Linkage Hole and insert 3/4 x 5-5/16 Pin. Add 3/4 Flat Washer on each side of the Pin. Secure with 3/16 x 1-1/2 Cotter Pin. **See Figure 2-19.**

Manually check the Linkage to ensure there is no binding and no interferences with the Tines when Tooth Tubes are rotated.

Install the Cylinder Bracket to the front of the Rear Frame Tube aligning the Cylinder Bracket Lug with the rear Tooth Control Bracket Lug. Attach Cylinder Bracket to Rear Frame Tube with 4-Hole Plate, 5/8-11 X 8 Bolt, Lockwashers and Nuts.

Attach 3 X 8 Hydraulic Cylinder base end to the Cylinder Bracket Lug and the rod end of the Cylinder to the Tooth Control Bracket Lug with the Pins provided.

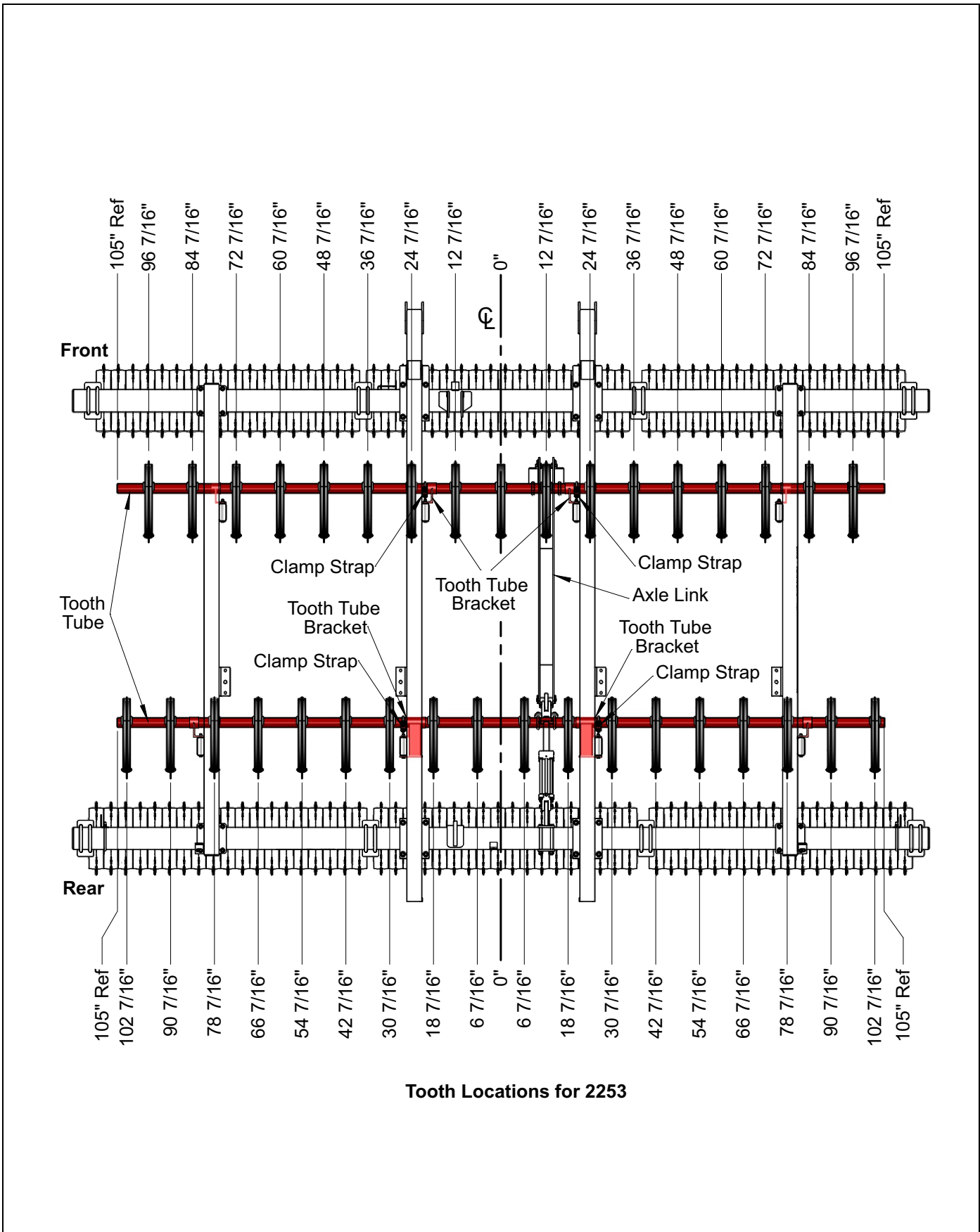

Figure 2-18: Tooth Locations

Independent Tooth Control C-Tooth Installation

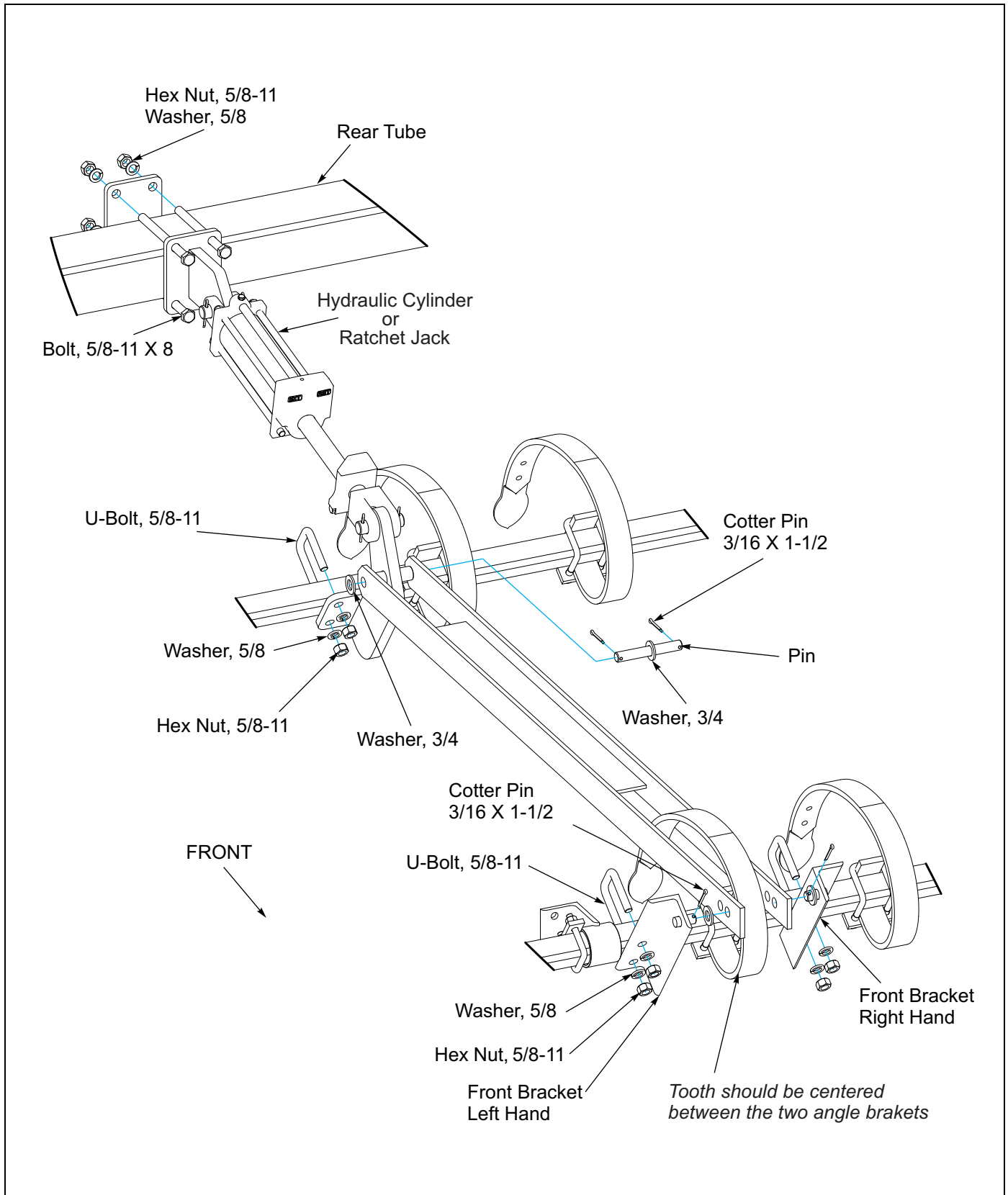

Figure 2-19: Independent Tooth Control C-Tooth Installation

Independent Tooth Control S-Tine Installation

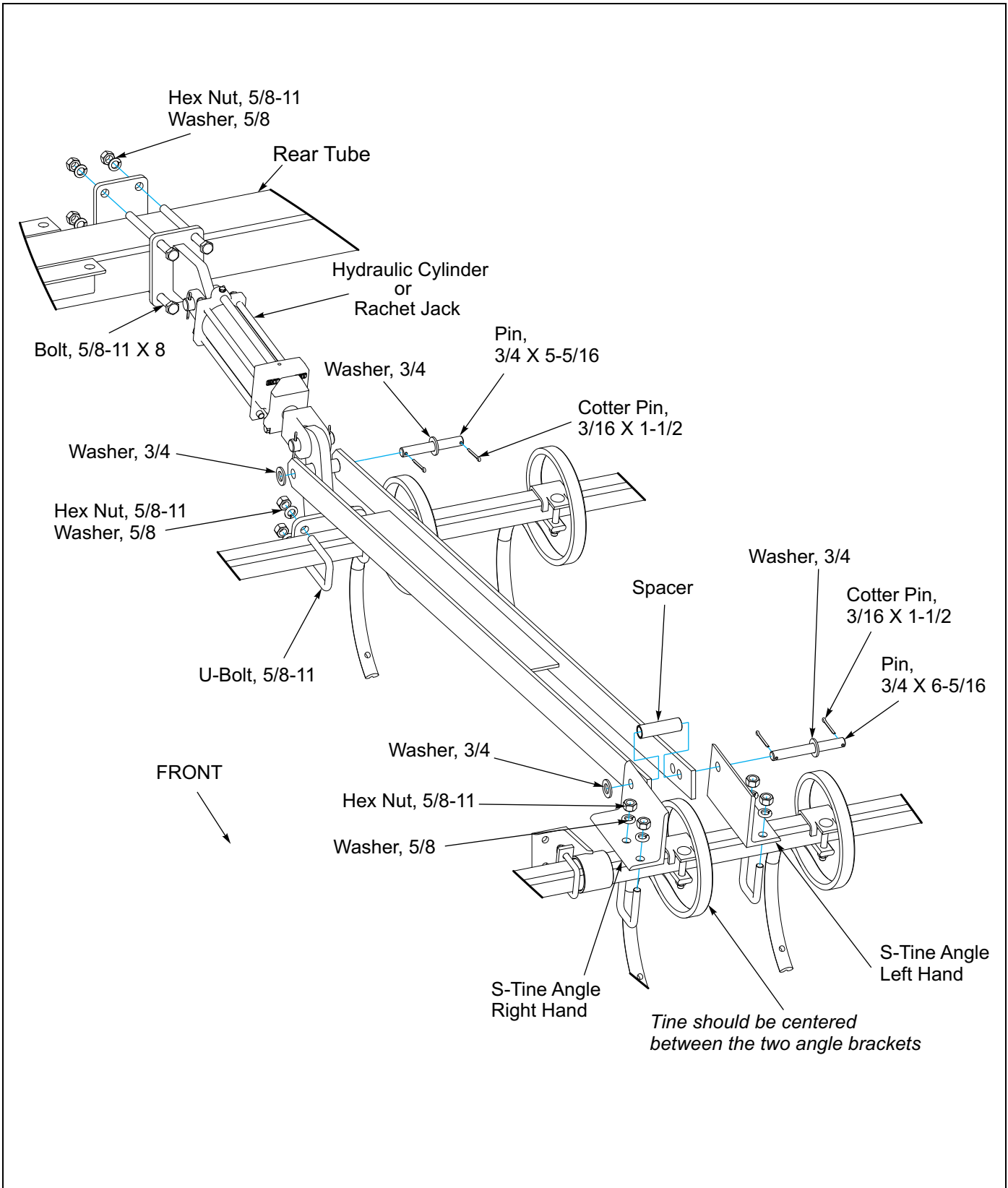

Figure 2-20: Independent Tooth Control S-Tine Installation

Bracket Relationship per Tine Style - Independent

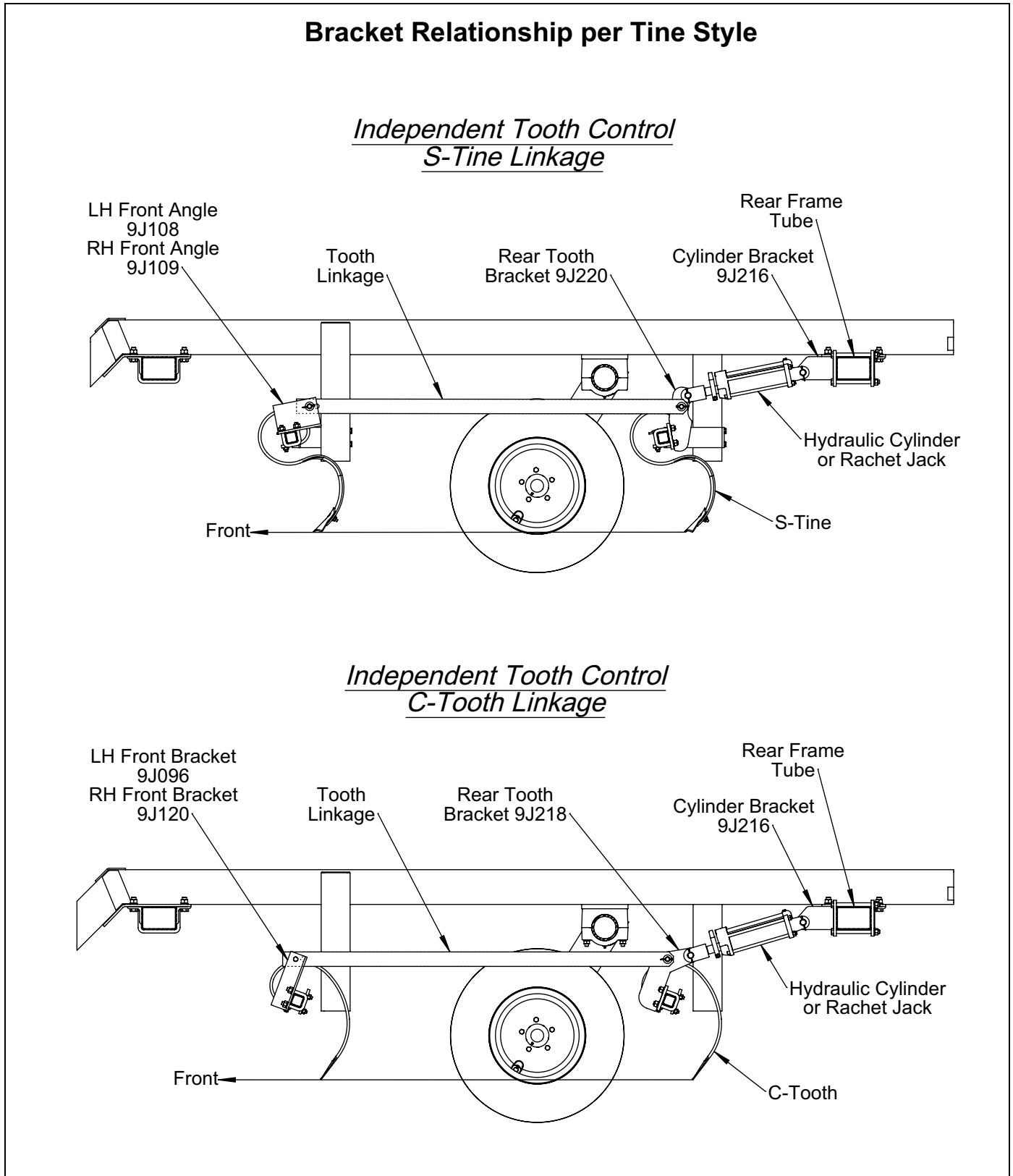

Figure 2-21: Bracket Relationship per Tine Style - Independent

Hydraulics



WARNING

Escaping fluid under pressure can be nearly invisible and have enough force to penetrate the skin causing serious injury. Use a piece of cardboard, rather than your hands, to search for suspected leaks. Wear protective gloves & safety glasses or goggles when working with hydraulic systems.



CAUTION

Do not raise the machine without the use of hydraulics. This would introduce air into the hydraulic cylinder. When the transport pin is removed the frame would lower rapidly possibly causing injury.

Tightening Procedure For JIC 37° Swivel Female Nuts

1. Check flare and seat for defects.
2. Lubricate the connection.
3. Install hoses without twists.
4. Hand tighten until connection bottoms.
5. Using 2 wrenches to prevent twisting, rotate the swivel nut 2 wrench flats (1/3 turn).
6. For reassembly, follow the same procedure but tighten only 1 wrench flat (1/6 turn).

Tightening Procedure For Swivel O-Ring Fittings

1. Lubricate o-ring and install the fitting until the metal washer which backs up the o-ring contacts the face of the boss.
2. Orient the fitting by turning counterclockwise up to 1 turn.

Tighten the lock nut using 50-60 foot pounds torque.

Remove Fitting caps prior to installing Fittings.

Transport Circuit

Refer for Transport Hydraulic Schematic. See **Figure 2-22**.

Transport 3-1/2 x 16 Hydraulic Cylinder ports should be upward. Install 90 degree O-Ring X Male JIC Elbow Fittings into each Cylinder port.

Install fittings to the relief valve per hydraulic schematic. Install hoses and the rest of the fittings. Route them along the LH Inner Frame Tube toward the front of the machine down the Drawbar under the Manual Canister Bracket through the Hose support accordingly.

Secure all hoses with cable ties and tie straps.

Independent Tooth Control Circuit

Refer to Independent Tooth Control Schematic. See **Figure 2-23**.

Install O-Ring X Male JIC Fitting into each Cylinder Port. Install hoses and the rest of the fittings. Route them along the Rear Frame Tube to the LH Inner Frame Tube toward the front of the machine along with the Transport Circuit hoses down the Drawbar through the Hose support accordingly.

Secure all hoses with cable ties and tie straps.

Fill the hydraulic system with oil.

Bleeding Hydraulic System

When the machine is assembled, or any time hydraulic circuit is opened, air must be bled from the system. Other wise, air will compress, allowing frame to free-fall.

Bleed the Tooth Control System by cycling the system five or six times completely. Cylinders should be fully extending and fully retracting and Tooth Control mechanism should be rotating without binding.

Transport Hydraulic Diagram

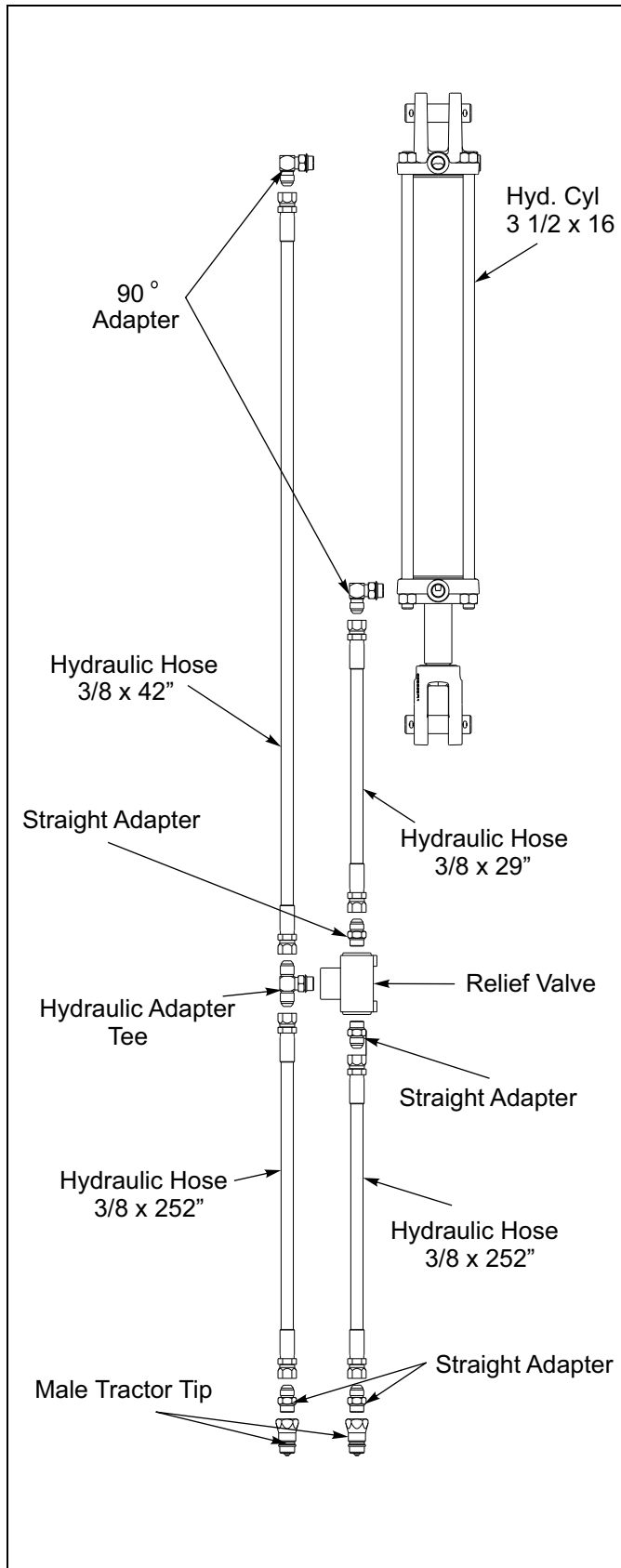

Figure 2-22: Transport Hydraulic Diagram

Independent Tooth Control - Hydraulic Diagram

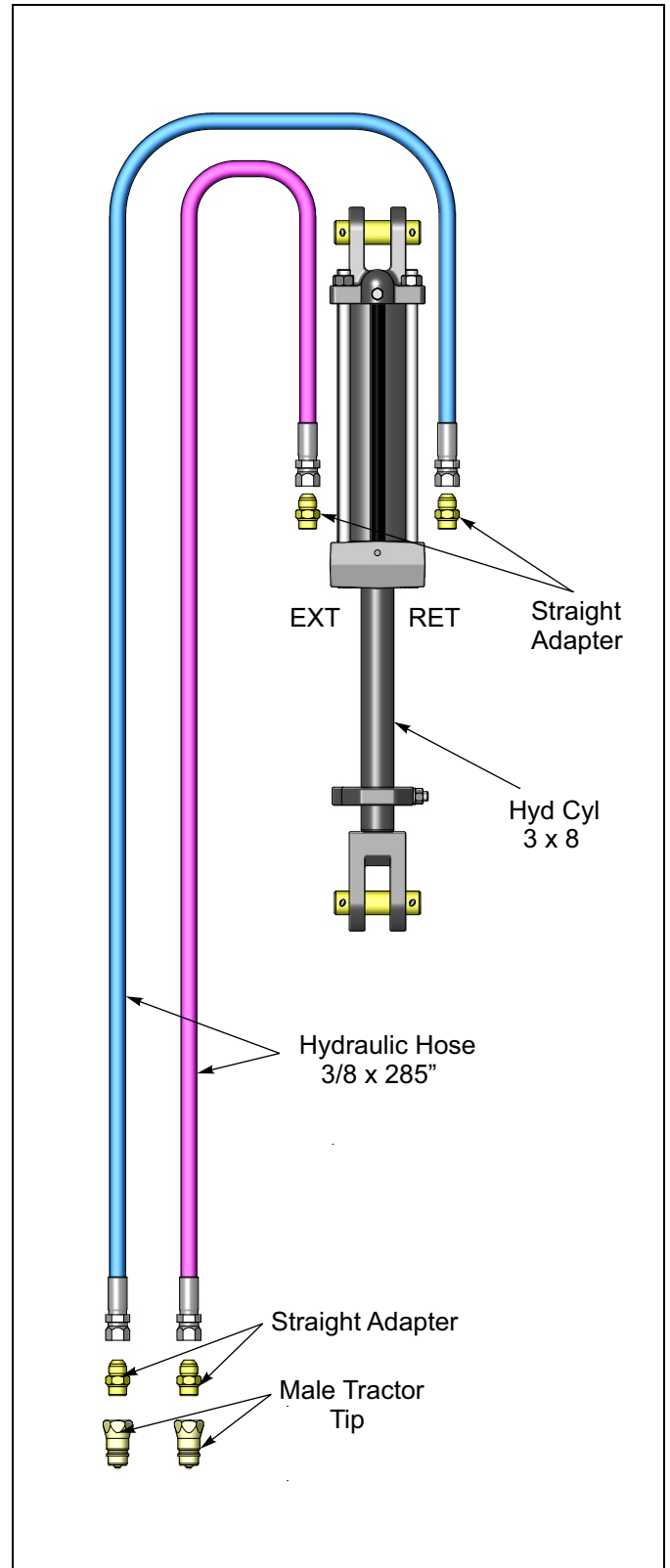
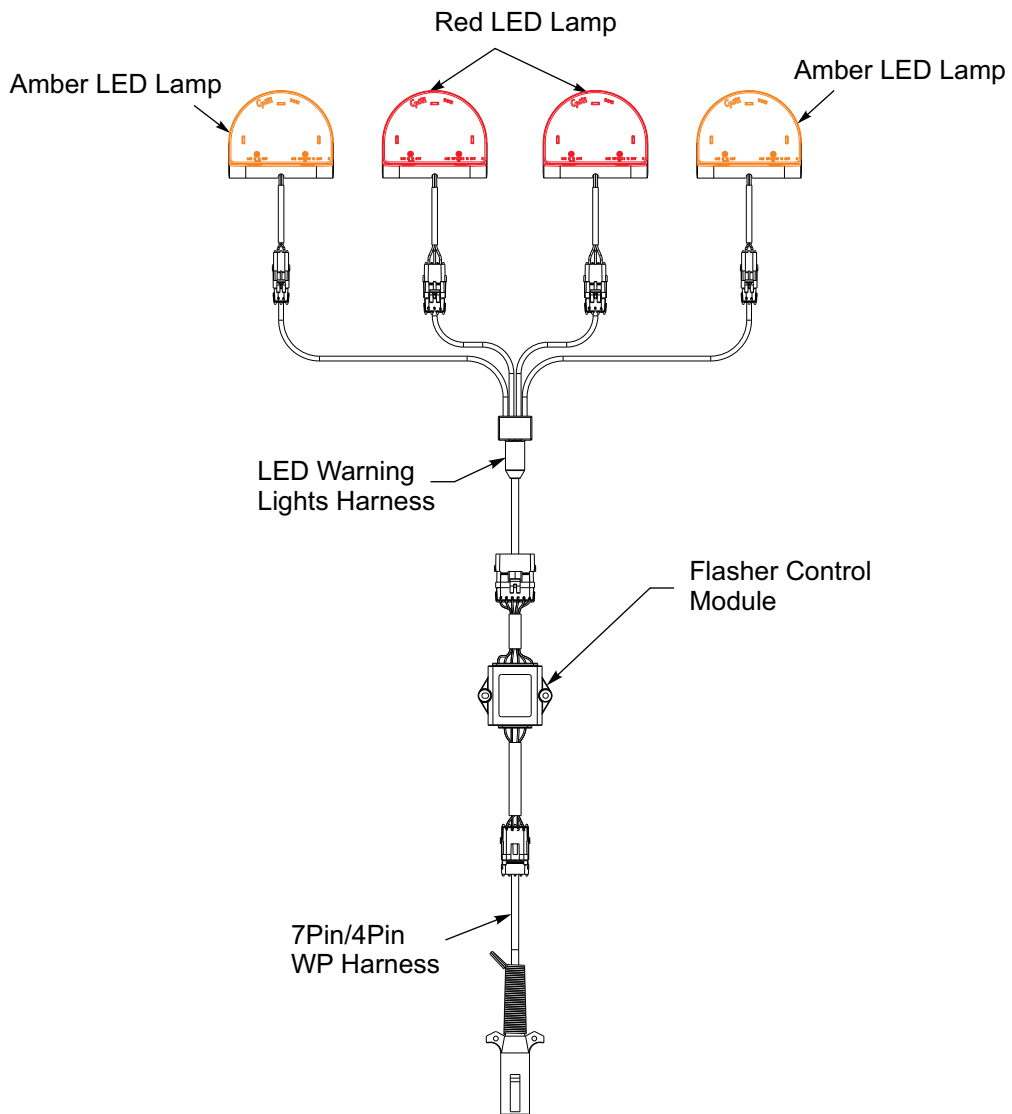

Figure 2-23: Independent Tooth Control - Hydraulic Diagram



When plugging in the LED 7-pin connector:

- 1) Make sure the tractor has a good clean receptacle, free of dirt and corrosion.
- 2) Make sure the 7-pin connector is inserted ALL the way in. With tighter fitting pins, operator may think the connector is all the way in, but really isn't.
- 3) Make sure the tractor receptacle cover latches over the keyway on the 7-pin connector to hold the connector in place.

If an operator plugs in the 7-pin connector, but the lights do not seem to work right, check the above items to make sure there is a good connection with the 7-pin connector.

Figure 2-24: LED Schematic

LED Lamp and Harness Installation

NOTE

Unless otherwise noted the following installation instructions apply to all ML Models.

1. Install a Lamp Bracket approximately 31 inches from center line on each side of the rear frame tube using 1/2-13 U-Bolts and Flanged Locknuts. **See Figure 2-26.**
2. With the Red LED Lamp facing rearward, attach the Lamp to the outside and the Decal Bracket to the inside of the Lamp Bracket using 1/4-20 x 1-1/2 Screws and Locknuts. **See Figure 2-24.**
3. Install a Lamp Bracket approximately 7-1/2 inches from each end of the rear frame tube using 1/2-13 U-Bolts and Flanged Locknuts. **See Figure 2-26.**
4. Place the Amber LED inside the Light Shield. Attach Lamp and Shield to the outside and the Decal Bracket to the inside of the Lamp Bracket with 1/4-20 x 1-3/4 Screws and Locknuts. **See Figure 2-24.**
5. Attach the Light Module to the Light Module Bracket using two 1/4-20 X 1-1/2 Screws and Locknuts. **See Figure 2-25.**
6. Attach the Light Module Bracket to the rear of the left Inner Frame Tube just in front of the Rear Frame Tube using 3/8-16 U-Bolts and Locknuts.

NOTE

Connectors marked with Yellow Tape is Left Side and Green Tape is Right Side.

7. Layout the LED Lamp Harness along the Rear Frame Tube with the 3 way and the 2 way connector cords marked with yellow tape on the left side and the 3 way and the 2 way connector cords marked with green tape on the right side of the machine. Plug the 3 way connectors into the Red Lamps and the 2 way connectors into Amber Lamps. Route the Harness up the Left Inner Frame Tube to the Light Module 6 way connector and connect.
8. Connect the 7 Pin Harness 4 way connector into the Light Module. Run the Harness along the Left Inner Frame Tube with the Hydraulic Hoses, down the Drawbar Loops and through the Hose Holder to the Hitch Point.
9. Bundle and secure any excess cord with tie straps.
10. Apply the reflector decals to Decal Plate Mounts. The amber reflector decals should be front facing on the outer Decal Plate Mounts. The red reflector decals and orange decals should be rear facing on both the inner and outer decal plate mounts. **See Figure 2-24.**

IMPORTANT

All wires must be firmly attached to machine frame members, or hydraulic lines, so they don't sag or become torn loose by field debris. Use the cable and hose ties provided.

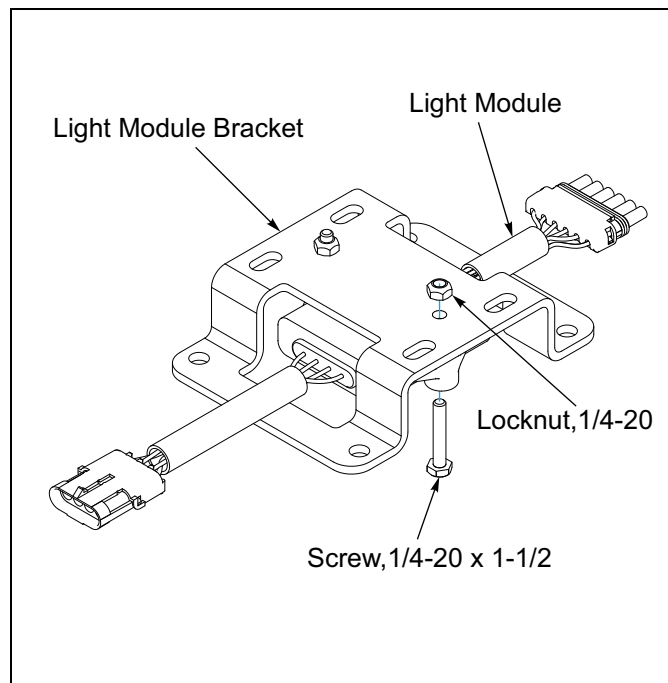

Figure 2-25: LED Module and Bracket

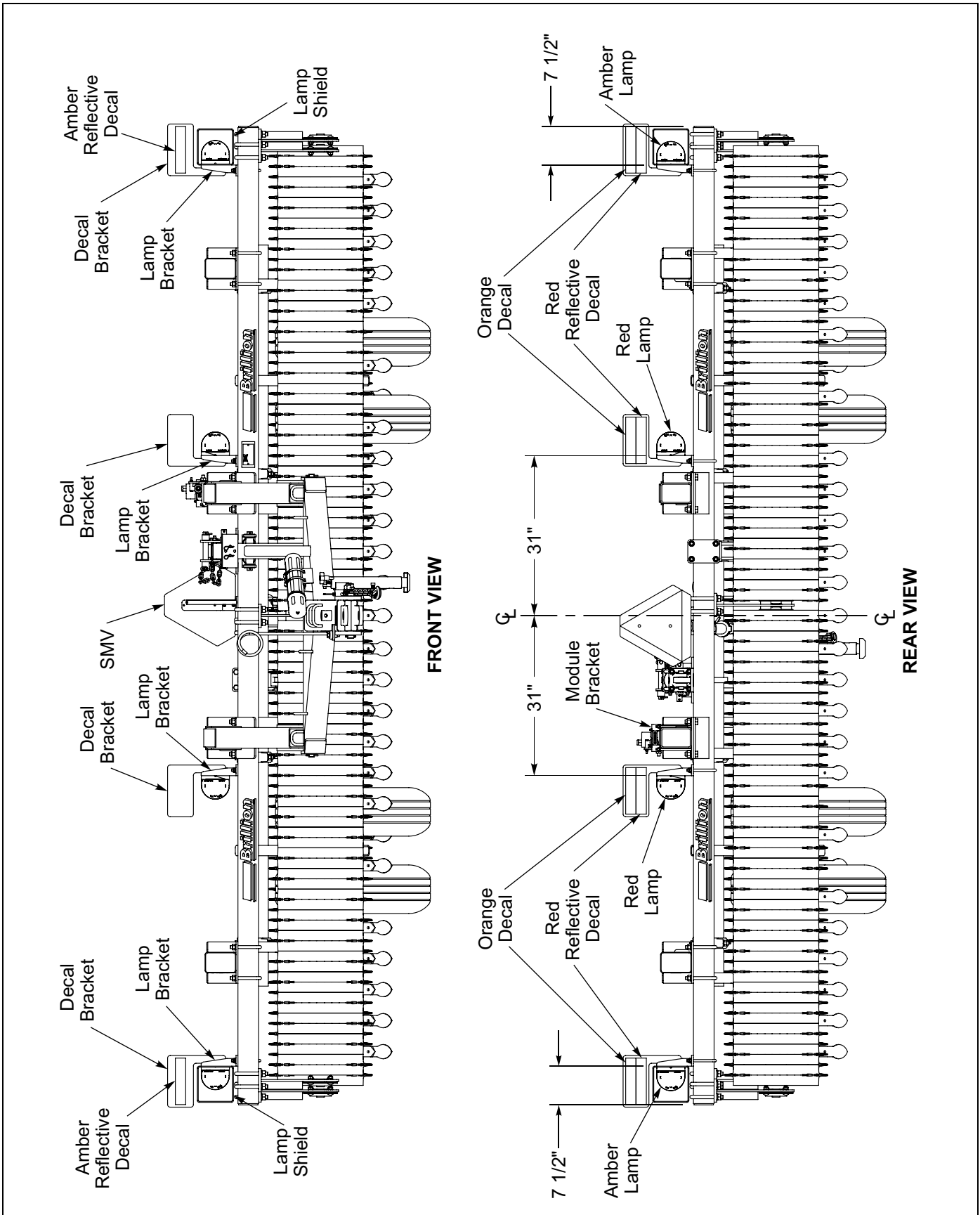

Figure 2-26: LED Warning Lights Installation Dimensions

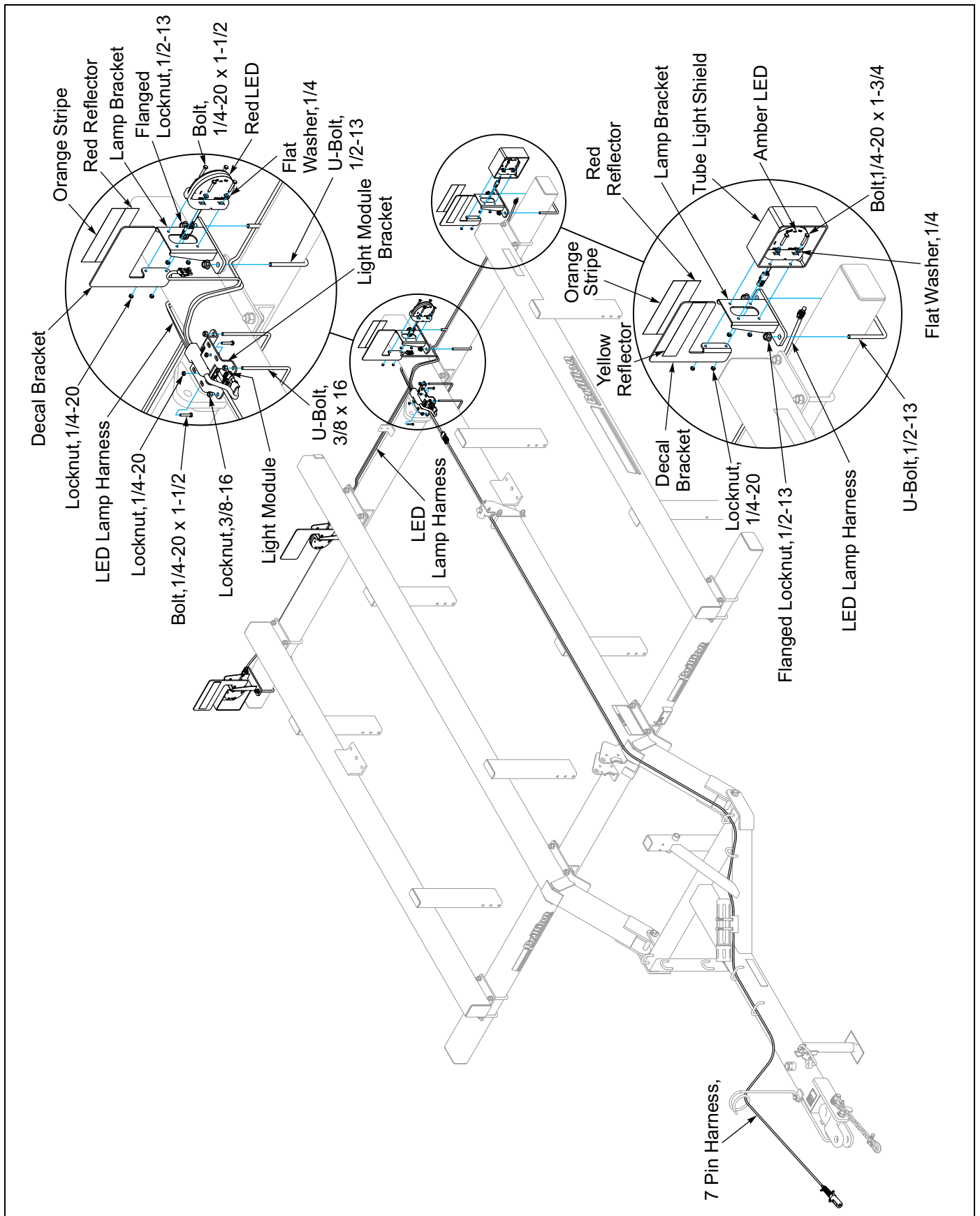

Figure 2-27: LED Lamp Installation

Scrapers - Standard on Rear

For 20" wheels, Scrapers are installed as shown. **See Figure 2-28.** The Scraper Brackets are located on the inside of the End Brackets and attach with U-bolts 3/8-16 X 3-1/4 X 2-7/16, Flat Washers, Lockwashers, and Nuts. The Scraper Tubes are to be centered with respect to the machine and are fixed between the

Scraper Bracket and a narrow 2" wide Scraper with U-bolt 3/8-16 X 3-1/4 X 2-7/16, Flat Washers, Lockwashers, and Nuts. The narrow 2" wide Scrapers are also used at the inner end of each axle assembly.

Optional Front Scrapers - Install similar to rear Scrapers.

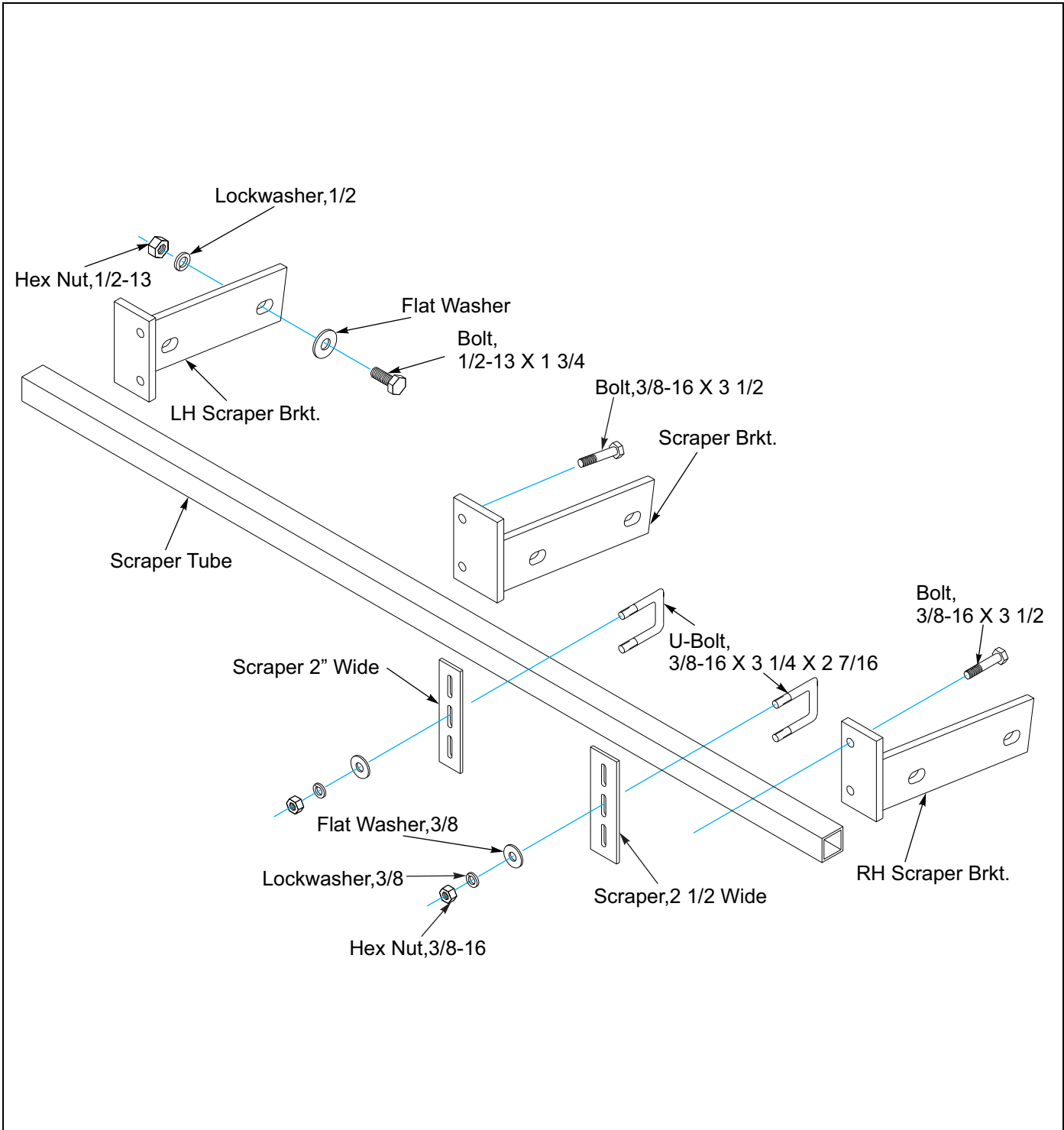

Figure 2-28: Scrapers

Rear Hitch - Optional

Attach the Rear Hitch between the Inner Frame Tubes. Insert 5/8-11 x 6 Bolts through the diagonal Braces and Hitch. Secure with Lockwashers and Nuts. Insert the Tandem Harness Adapter through the bulkhead, secure with 1/4-20 Bolts and Locknuts. **See Figure 2-29.**

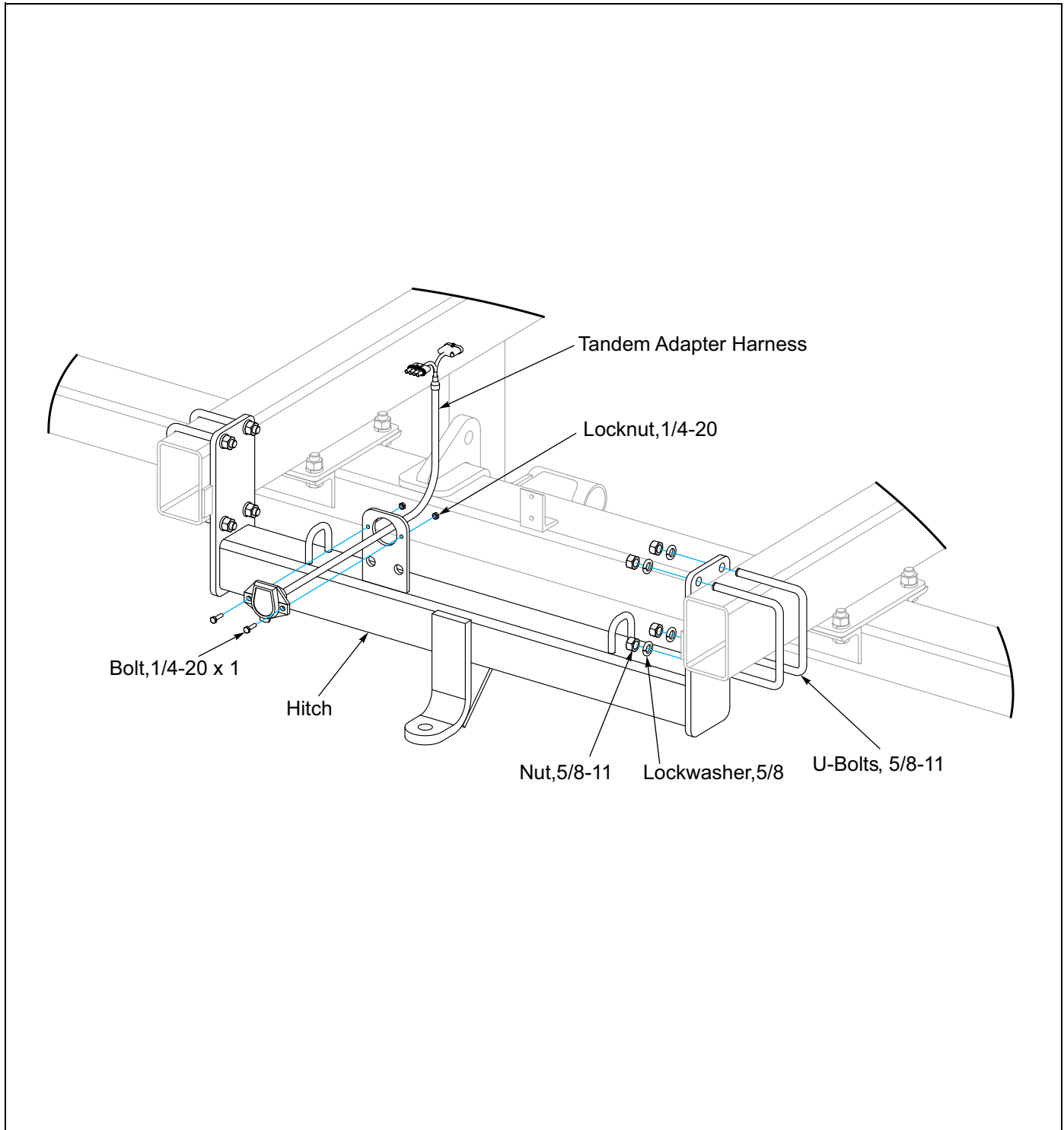

Figure 2-29: Rear Hitch

Land Leveler - Optional

Note: There are both Left and Right Brackets and Adjusting Angles. Left hand installation shown, Right hand is similar. See Figure 2-30.

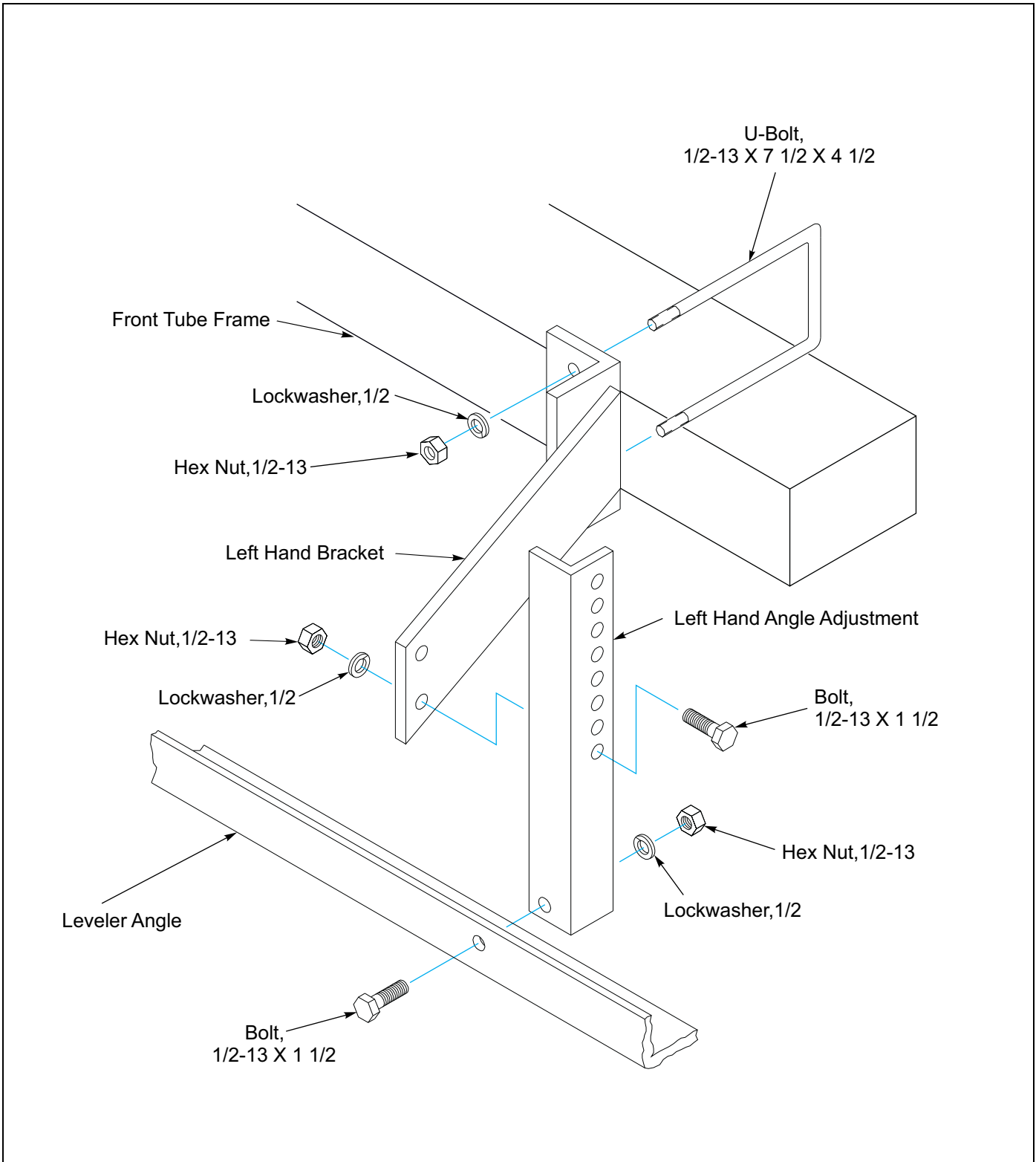

Figure 2-30: Land Leveler

V Leveler - Optional

Note: Position Leveler Weldment, centered in front of the Pulvi-Mulcher. Attach to Frame and Drawbar with Brackets and Hardware items shown. Vertical Adjustment may be required in the field.

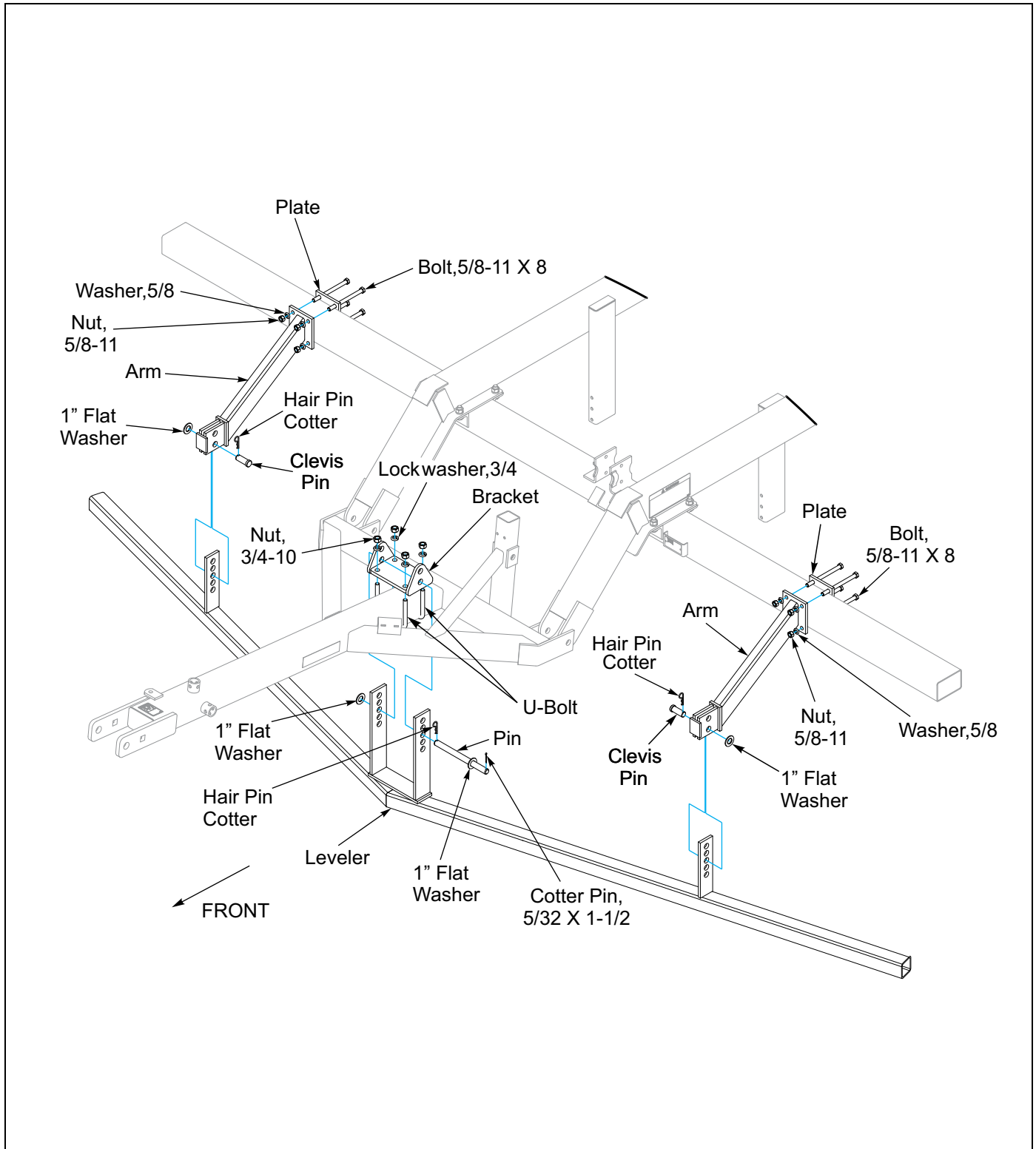

Figure 2-31: V Leveler

Chapter 3

Operation



DANGER

Never allow anyone to ride on the Pulvi-Mulcher at any time. Allowing a person to ride on the machine can inflict serious personal injury or death to that person.



WARNING

All hydraulically elevated equipment must have cylinder lockouts installed or be lowered to the ground, when servicing or when equipment is idle. Failure to take preventive measures against accidental lowering can result in serious personal injury.



CAUTION

Ensure both Rockshaft Transport Locks are either locked or unlocked. Failure to lock Transport Locks may result in damage to the machine.

Ensure the Drawbar Transport Lock is unlocked before lowering the machine. Failure to remove the Pin will result in damage to the drawbar and frame.



CAUTION

When transporting farm implements on public roads, it is the responsibility of the operator to abide by state and local laws concerning wide loads, speed, safety emblems and safety lighting equipment. Drive at safe speeds, particularly when rounding corners, crossing rough ground or driving on hillsides, to prevent tipping the tractor.

General Operation

1. The minimum horsepower requirements are typically 6-8 horsepower per foot. This will vary widely due to speed, depth, moisture, residue and types of soils. Local dealers can help in making recommendations for your areas.
2. Operating speed is typically 5-8 mph. Excessive speed can cause rapid sweep/point wear. Reduce speed in rocky conditions to prevent wheel breakage.
3. Lift wheels must always be in raised position. It is not necessary to raise machine up on transport wheels during turns.
4. Do not turn with the teeth in the ground, this can put excessive side load on the Tines. Raise the Tines slightly using hydraulic tooth control when making turns to prevent bent or broken Tines, additionally excessive side load can also bend the Tine Tubes.
5. Allow just enough looseness so each wheel will turn by itself. If wheels become worn, loosen the clamp at the end of each roller axle and tighten as needed.
See Figure 4-4.

Level Adjustment

To adjust the front of the machine higher during transport, add spacers between the bumper and Drawbar Center Mast. See **Figure 3-1**.

Spring Adjustment

The Springs are used to cause the rear of the machine to lift before the front during the raising cycle (this prevents jolts when it shifts from rear-heavy to front-heavy). Tighten springs only to the level to accomplish this. See **Figure 3-4**.

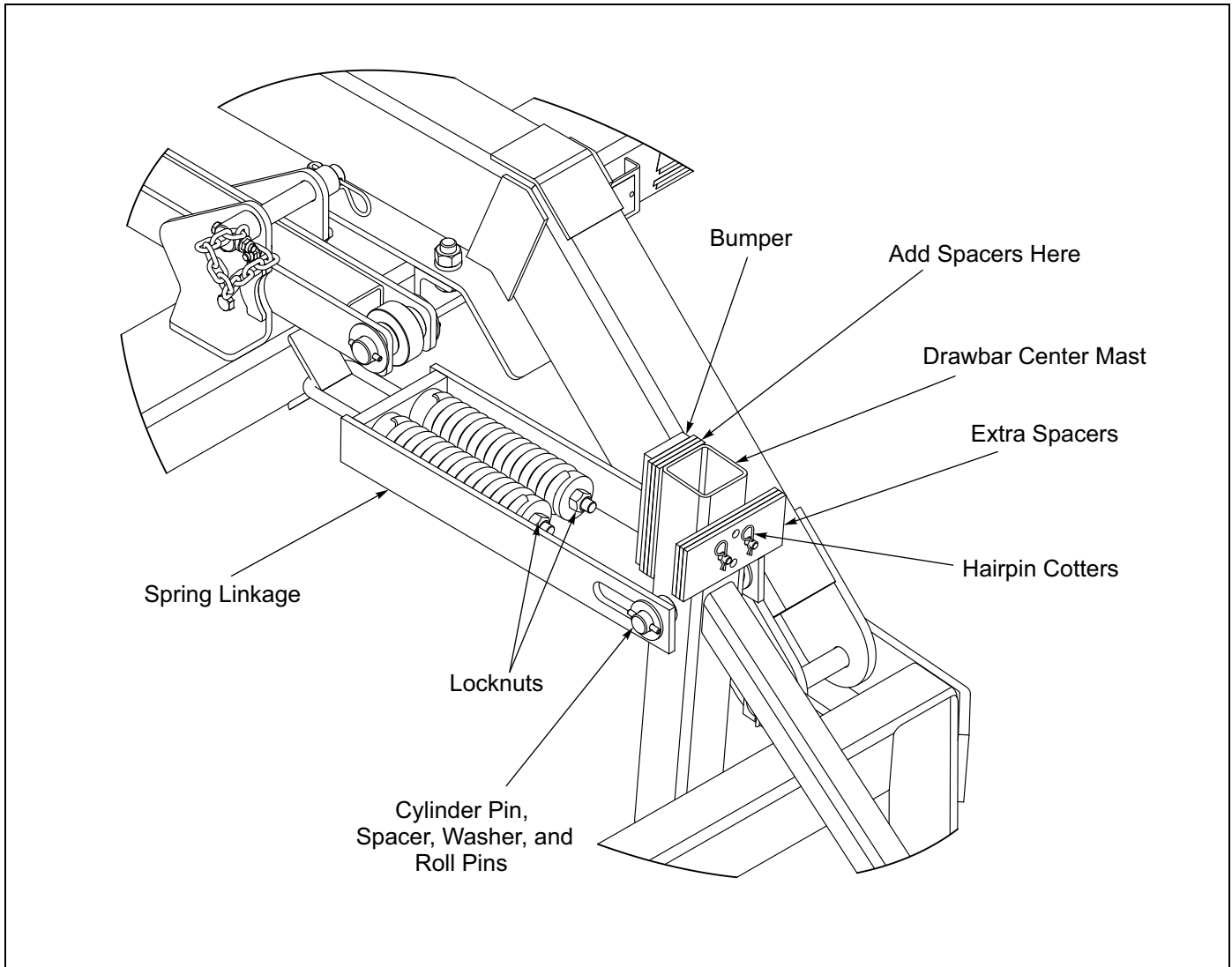

Figure 3-1: Level Adjustment

Transport Lock After July 2016

Prepare the machine for transport

Raise the machine and fold the wings, ensure Lift Cylinders are fully extended.

Insert the Transport Link Pin into the Transport Axle Link hole in front of the front frame tube angles. Place spacer on Transport Link Pin and secure with Hair Pin Cotter.

See Figure 3-2.

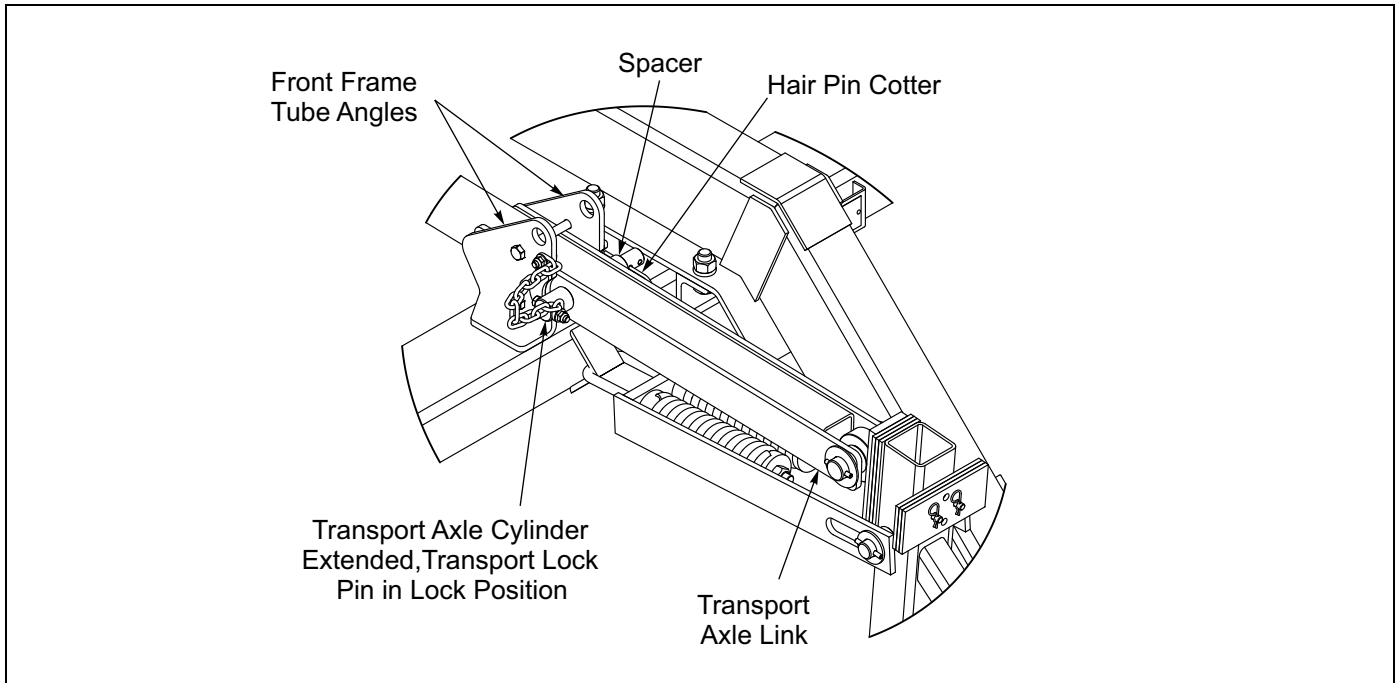

Figure 3-2: Transport Lock Pin in Lock Position

Prepare the machine for field operation

Unfold the Wings then raise the machine slightly to loosen the Transport Lock Pin. Remove the Transport Lock Pin from the Link. Insert the Pin into the top hole of the front frame tube angle. Place spacer on Transport Link Pin and secure with Hair Pin Cotter.

Lower the machine until the Wheel and Tire Assemblies are off the ground and the Lift Cylinder is retracted completely. **See Figure 3-3.**

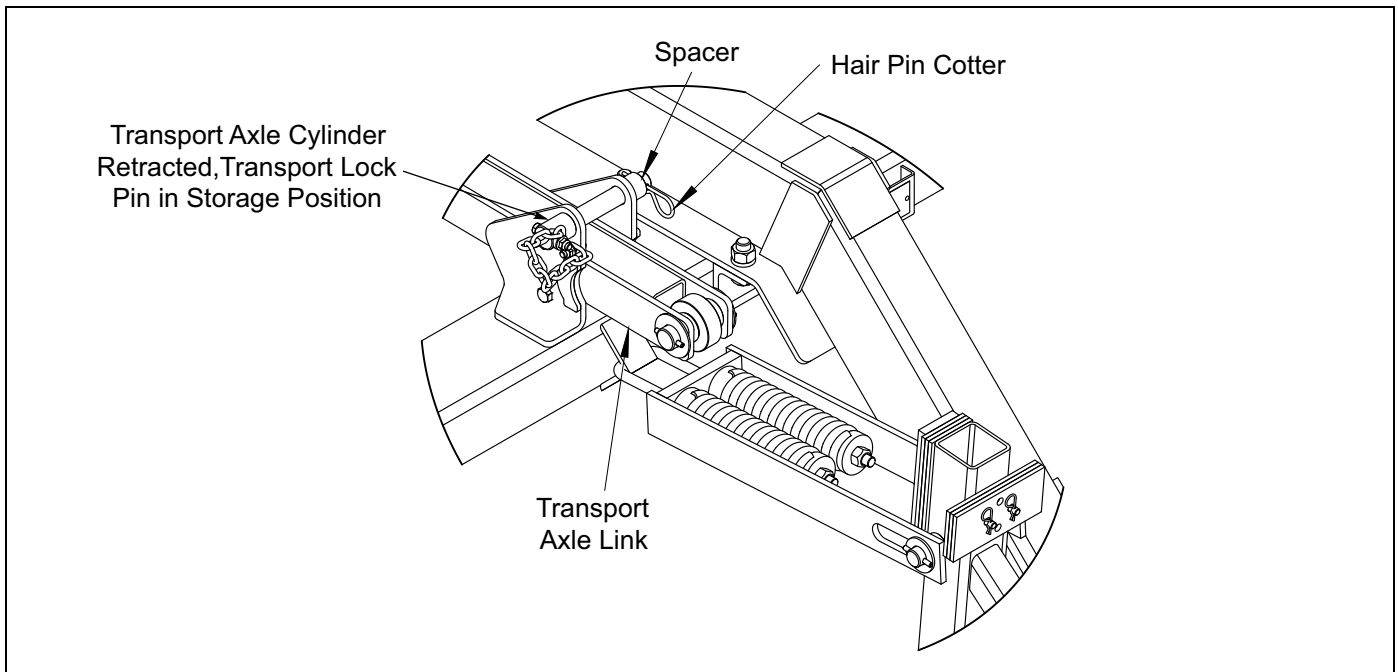

Figure 3-3: Transport Lock Pin in Storage Position

Transport Lock Prior to July 2016

Prepare the machine for transport

Raise the machine and fold the wings, ensure Lift Cylinders are fully extended.

Remove the Transport Lock Pin from the Link rear hole (storage position). Insert the Pin in the Link second hole from the rear (transport lock position) and in front of the front frame tube angles. **See Figure 3-4.**

Prepare the machine for field operation

Unfold the Wings then raise the machine slightly to loosen the Transport Lock Pin. Remove the Transport Lock Pin from the Link second hole from the rear (transport lock position). Insert the Pin in the Link rear hole (storage position). Lower the machine until the Wheel and Tire Assemblies are off the ground and the Lift Cylinder is retracted completely. **See Figure 3-4.**

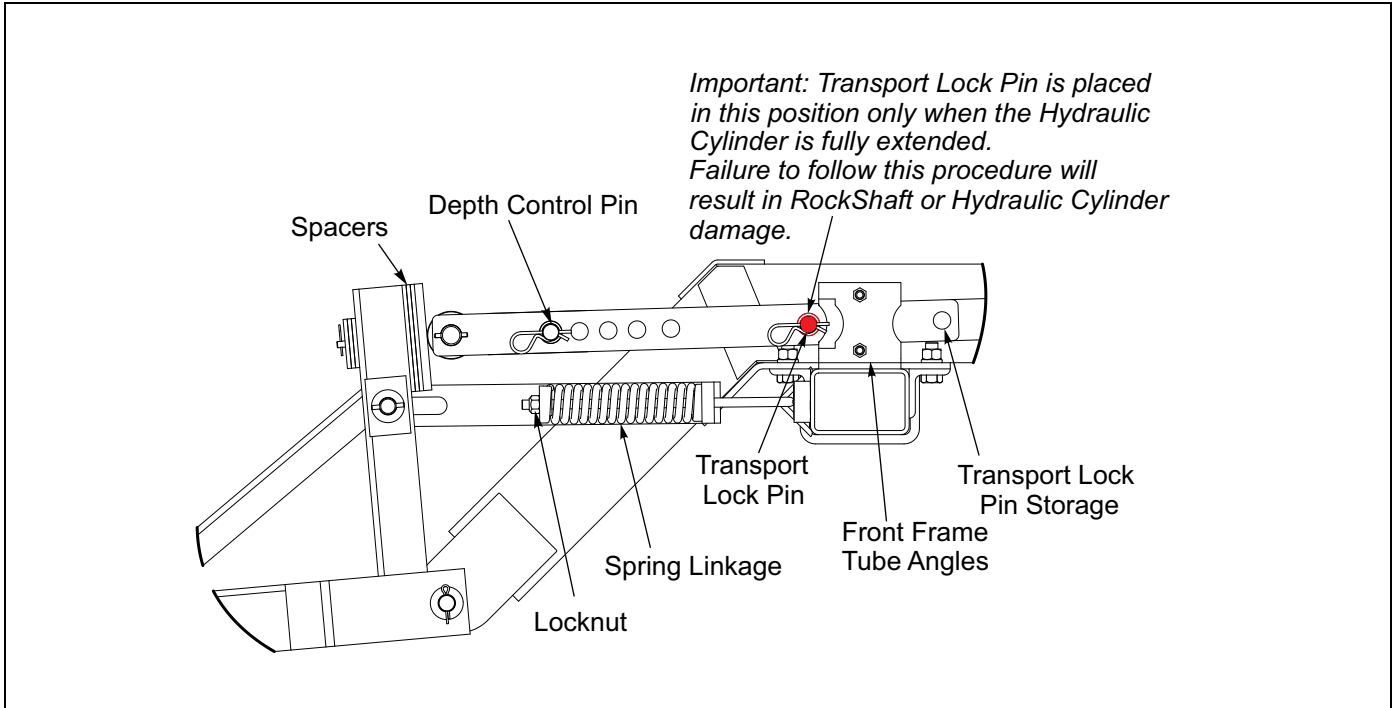

Figure 3-4: Spring Adjustment

Depth Control

S-Tine and C-Tooth depth is controlled by adjusting the position of the 3 X 8 Cylinder Striker Plate limiting the retraction length of the cylinder. *When the cylinder is fully extended the Tine/Tooth is completely out to the ground.* See Figure 3-3.

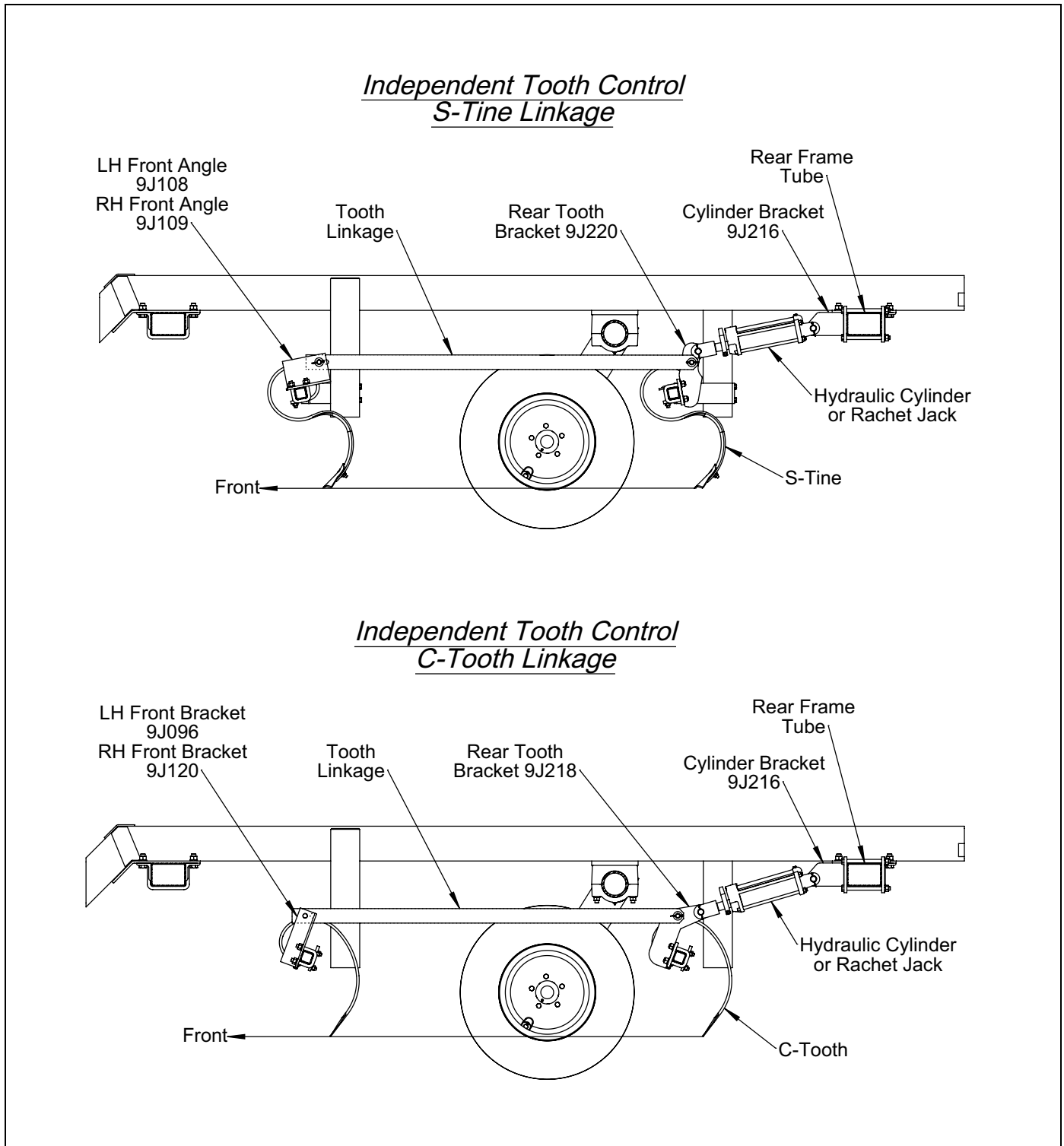

Figure 3-5: Depth Control



WARNING

Escaping hydraulic fluid can cause serious personal injury. Relieve system pressure before repairing, adjusting, or disconnecting. Wear proper hand and eye protection when searching for leaks. Use cardboard instead of hands. Keep all components (cylinders, hoses, fittings, etc.) in good repair.

Charging the Hydraulic System

To charge the system, carefully hitch the Pulvi-Mulcher to a tractor. Check the tractor hydraulic fluid level to make sure it is full of the manufacturer's recommended hydraulic fluid. Connect the cylinder hoses to the tractor and fully extend and retract the cylinder several times. The cylinder rod travel should be smooth and positive when all air has been purged from the system. Due to large amounts of hydraulic oil required, recheck the tractor fluid level to make sure it is within proper operating limits.

This machine consists of two hydraulic circuits. One for the Lift the other is for Tooth Control Circuit.

Hydraulic Lift Circuit

The Pulvi-Mulcher is equipped with a hydraulic lift circuit that raises/lowers the machine. The tractor should be stopped and not moving on a level area.

For Transport

Raise the machine. Ensure that the lift cylinders are fully extended. Install the Transport Lock Pin. **See Figure 3-2.**

For Field Operation

Raise the machine slightly to loosen the Transport Lock Pin. Remove Transport Lock Pin and place it in the upper hole on the Front Frame Tube Angles. **See Figure 3-3.** Lower the machine until the Wheel and Tire Assemblies are off the ground and the lift cylinder is completely retracted.

Tooth Control Circuit

The Tooth Control Circuit is used to engage and disengage the tines into the soil. When the cylinder is fully extended the Tine/Tooth is completely out to the ground.

Reflectors and SMV Sign

Reflectors and a slow moving vehicle sign (SMV) are required if the Pulvi-Mulcher is transported on a public road.

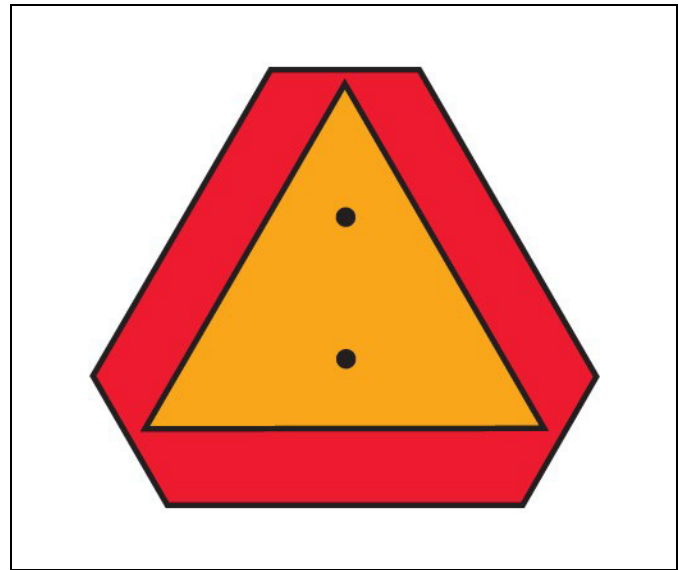

Figure 3-6: SMV Sign

Transport

1. Check and follow all federal, state, and local requirements before transporting the Pulvi-Mulcher.
2. The Pulvi-Mulcher should be transported only by tractor required for field operation. The implement weight should not exceed more than 1.5 times the tractor weight. Maximum transport speed for the Pulvi-Mulcher is 20 mph for the implement and is designated on the speed identification symbol located on the front of the implement.



CAUTION

Excessive speed may result in loss of control of the tractor and implement, reduced braking ability, or failure of the implement tire or structure. Do not exceed the implement maximum specified ground speed regardless of the capability of the maximum tractor speed.

3. When towing equipment in combination, the maximum equipment ground speed shall be limited to the lowest specified ground speed of any of the towed implements.
4. Maximum transport speed shall be the lesser of travel speed specified in the operator's manual, speed identification symbol, information sign of towed equipment, or limit of road conditions.
5. Slow down when driving on rough roads. Reduce speed when turning, or on curves and slopes to avoid tipping. Equipment altered other than the place of manufacture may reduce the maximum transport speed. Additional weight, added tanks, harrowing attachments, etc. may reduce implement load carrying capabilities.
6. A safety chain is provided with the implement to insure safe transport.
 - The safety chain should have a tensile strength equal to or greater than the gross weight of the implement. The chain is attached to the lower hitch clevis hole with two flat washers between the clamp plates to assure a tight connection. Always use a 1" diameter Grade 8 bolt for this connection.
 - Attach the safety chain to the tractor drawbar. **See Figure 1-2.** Provide only enough slack in the chain for turning. Do not use an intermediate chain support as the attaching point for the chain on the tractor. Do not pull the implement by the safety chain.

Regularly inspect the safety chain for worn, stretched, or broken links and ends. Replace the safety chain if it is damaged or deformed in any way.

7. Check that tires are of proper size, load rating, and inflated to manufacture specifications before transporting. Check wheel lug bolts to ensure tightness.
8. Know the transport heights and widths of the unit before transporting. Use caution when transporting near bridges and power lines.



WARNING

Electrocution can occur without direct contact

9. Raise the machine to full transport height.
10. Install transport locks on lift systems. Do not depend solely on implement hydraulics for transport.



WARNING

Failure to use transport lock pins during transport may result in permanent equipment damage, serious injury or death

11. Transport during daylight hours when ever possible. Always use flashing warning lights, except where such use is prohibited by law. Make sure lights, reflectors and SMV emblem are clearly visible and operating. remove any obstructions such as dirt, mud, stalks or residue that restricts view before transporting.



CAUTION

Do not attempt to remove the pin connecting the cylinder to the rockshaft if there is any load on the cylinder. The machine will fall and may cause injury.

Wheel Adjustment

Allow just enough looseness so each wheel will turn by itself. If the wheels become worn, loosen the axle clamp at the end of each roller and tighten as needed. Optimum performance is achieved when the roller segments are operated snugly together.

Scraper Adjustment

Rear scrapers are standard equipment and front scrapers are optional.

The roller scraper is designed to keep the roller from building up with moist soil during operation. To adjust the scrapers; lower machine on level surface. Adjust scrapers to obtain 1/4" gap between scrapers and wheels. The Scrapers for the 20" wheels are reversible.

Land Leveler - Optional

Adjust the Land Leveler to the highest position that does the required job. Its purpose is to break up and scatter any large lumps that are above the normal ground level. If the soil pushes ahead of the bar, its set too low. Striking large rocks will damage the leveler bar and possibly other parts of the machine.

V Leveler - Optional

Adjust the V Leveler to the highest position that does the required job. Its purpose is to break up and displace any large lumps that are above the normal ground level with minimal planing. Striking large rocks will damage the leveler bar and possibly other parts of the machine. **See Figure 3-7.**

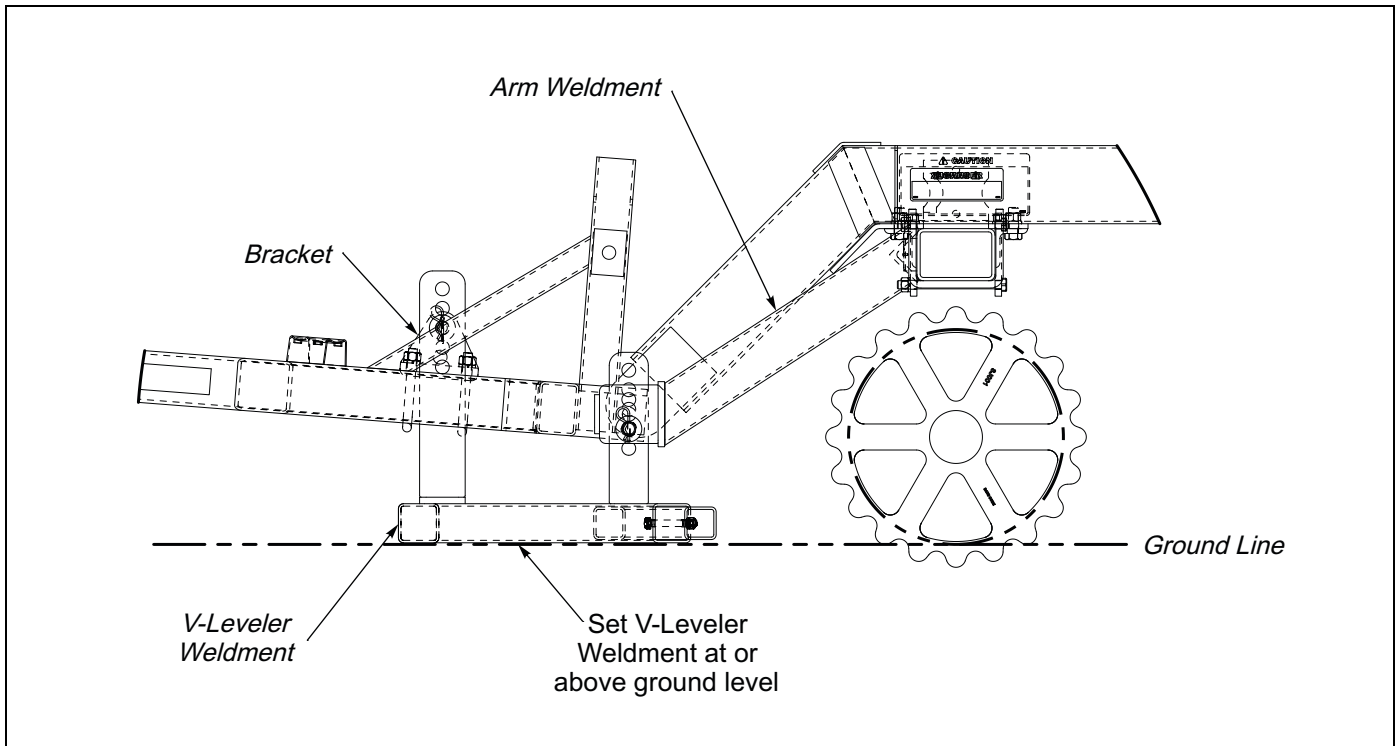

Figure 3-7: V-Leveler Side View

Maintenance

General Torque Specifications

(rev. 4/97)

This chart provides tightening torques for general purpose applications when special torques are not specified on process or drawing. Assembly torques apply to plated nuts and capscrews assembled without supplemental lubrication (as received condition). They do not apply if special graphite moly-disulfide or other extreme pressure lubricants are used. When fasteners are dry (solvent cleaned) add 33% to as received condition torque. Bolt head identification marks indicate grade and may vary from manufacturer to manufacturer. Thick nuts must be used on grade 8 capscrews. Use value in [] if using prevailing torque nuts

TORQUE SPECIFIED IN FOOT POUNDS

UNC SIZE	SAE Grade 2	SAE Grade 5	SAE Grade 8	UNF SIZE	SAE Grade 2	SAE Grade 5	SAE Grade 8
1/4-20	4 [5]	6 [7]	9 [11]	1/4-28	5 [6]	7 [9]	10 [12]
5/16-18	8 [10]	13 [13]	18 [22]	5/16-24	9 [11]	14 [17]	20 [25]
3/8-16	15 [19]	23 [29]	35 [42]	3/8-24	17 [21]	25 [31]	35 [44]
7/16-14	24 [30]	35 [43]	55 [62]	7/16-20	27 [34]	40 [50]	60 [75]
1/2-13	35 [43]	55 [62]	80 [100]	1/2-20	40 [50]	65 [81]	90 [112]
9/16-12	55 [62]	80 [100]	110 [137]	9/16-18	60 [75]	90 [112]	130 [162]
5/8-11	75 [94]	110 [137]	170 [212]	5/8-18	85 [106]	130 [162]	180 [225]
3/4-10	130 [162]	200 [250]	280 [350]	3/4-16	150 [188]	220 [275]	320 [400]
7/8-9	125 [156]	320 [400]	460 [575]	7/8-14	140 [175]	360 [450]	500 [625]
1-8	190 [237]	408 [506]	680 [850]	1-14	210 [263]	540 [675]	760 [950]
1-1/8-7	270 [337]	600 [750]	960 [1200]	1-1/8-12	300 [375]	660 [825]	1080 [1350]
1-1/4-7	380 [475]	840 [1050]	1426 [1782]	1-1/4-12	420 [525]	920 [1150]	1500 [1875]
1-3/8-6	490 [612]	1010 [1375]	1780 [2225]	1-3/8-12	560 [700]	1260 [1575]	2010 [2512]
1-1/2-6	650 [812]	1460 [1825]	2360 [2950]	1-1/2-12	730 [912]	1640 [2050]	2660 [3325]

METRIC:

Coarse thread metric class 10.9 fasteners and class 10.0 nuts and through hardened flat washers, phosphate coated, Rockwell "C" 38-45. Use value in [] if using prevailing torque nuts

Nominal thread diameter (mm)	Newton Meters (Standard Torque)	Foot Pounds (Standard Torque)	Nominal Thread Diameter (mm)	Newton Meters (Standard Torque)	Foot Pounds (Standard Torque)
6	10 [14]	7 [10]	20	385 [450]	290 [335]
7	16 [22]	12 [16]	24	670 [775]	500 [625]
8	23 [32]	17 [24]	27	980 [1105]	730 [825]
10	46 [60]	34 [47]	30	1330 [1470]	990 [1090]
12	80 [125]	60 [75]	33	1790 [1950]	1340 [1450]
14	125 [155]	90 [115]	36	2325 [2515]	1730 [1870]
16	200 [240]	150 [180]	39	3010 [3210]	2240 [2380]
18	275 [330]	205 [245]			

Hydraulic Fitting Torque Specifications

37 degree JIC, ORS, &ORB (REV. 10/97)

This chart provides tightening torques for general purpose applications when special torques are not specified on process or drawing. Assembly torques apply to plated nuts and capscrews assembled without supplemental lubrication (as received condition). They do not apply if special graphite moly-disulfide or other extreme pressure lubricants are used. When fasteners are dry (solvent cleaned) add 33% to as received condition torque. Bolt head identification marks indicate grade and may vary from manufacturer to manufacturer. Thick nuts must be used on grade 8 capscrews. Use value in [] if using prevailing torque nuts

TORQUE SPECIFIED IN FOOT POUNDS

PARKER® BRAND FITTINGS

Dash Size	37 Deg. JIC	O-ring (ORS)	O-ring boss
-4	11-13	15-17	13-15
-5	14-16	-----	21-23
-6	20-22	34-36	25-29
-8	43-47	58-62	40-44
-10	55-65	100-110	58-62
-12	80-90	134-146	75-85
-16	115-125	202-218	109-121
-20	160-180	248-272	213-237
-24	185-215	303-327	238-262
-32	250-290	-----	310-340

GATES® BRAND FITTINGS

Dash Size	37 Deg. JIC	O-ring (ORS)	O-ring boss
-4	10-11	10-12	14-16
-5	13-15	-----	-----
-6	17-19	18-20	24-26
-8	34-38	32-40	37-44
-10	50-56	46-56	50-60
-12	70-78	65-80	75-83
-14	-----	65-80	-----
-16	94-104	92-105	111-125
-20	124-138	125-140	133-152
-24	156-173	150-180	156-184
-32	219-243	-----	-----

AEROQUIP® BRAND FITTINGS

Dash Size	37 Deg. JIC	O-ring (ORS)	O-ring boss
-4	11-12	10-12	14-16
-5	15-16	-----	16-20
-6	18-20	18-20	24-26
-8	38-42	32-35	50-60
-10	57-62	46-50	75-80
-12	79-87	65-70	125-135
-14	-----	-----	160-180
-16	108-113	92-100	200-220
-20	127-133	125-140	210-280
-24	158-167	150-165	270-360

Fasteners

Before operating your Brillion machine, check all hardware for tightness. Use the Tightening Torque Table below as a guide. See Page 4-1.

After a few hours of use, check entire machine and tighten any loose nuts or bolts. Daily or periodic checks should be made thereafter.

When replacing bolts, be sure to use fasteners of equal grade.

Tires

Recommended inflation pressure for the 9.5L X 15-6 Ply tire is 30-32 PSI.

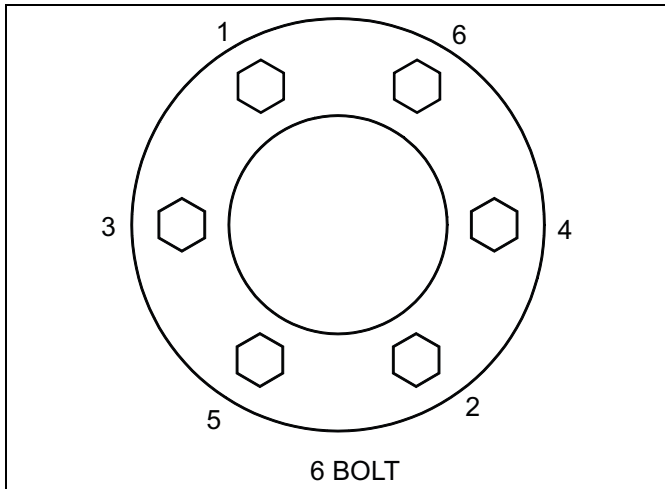

Figure 4-1: Tightening Sequence

Wheel Bearing Maintenance

Wheel bearing maintenance should be performed at the beginning of every season of use. Check the wheel bearing for excessive end play. If needed, adjust or replace them.

Lubricating Wheel Hub:

Grease Wheel Hubs every 40-60 hours.

Repack Wheel Hub bearings annually before each season usage. **See Figure 4-2.**

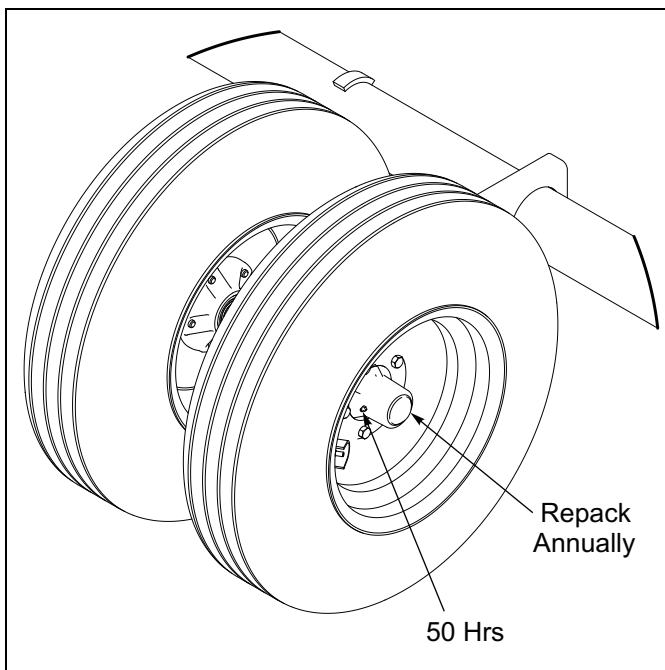

Figure 4-2 Wheel Hub

⚠ CAUTION

Over lubrication of these bearings can cause premature bearing failure.

Lubrication

Lubricate bearings with quality grease per recommended lubrication frequency intervals indicated or if machine is not used for an extended period. Greaseable components are the same on each side.

Grease zerk fittings daily. Each of the four rockshaft bearings has two fittings an upper and lower.

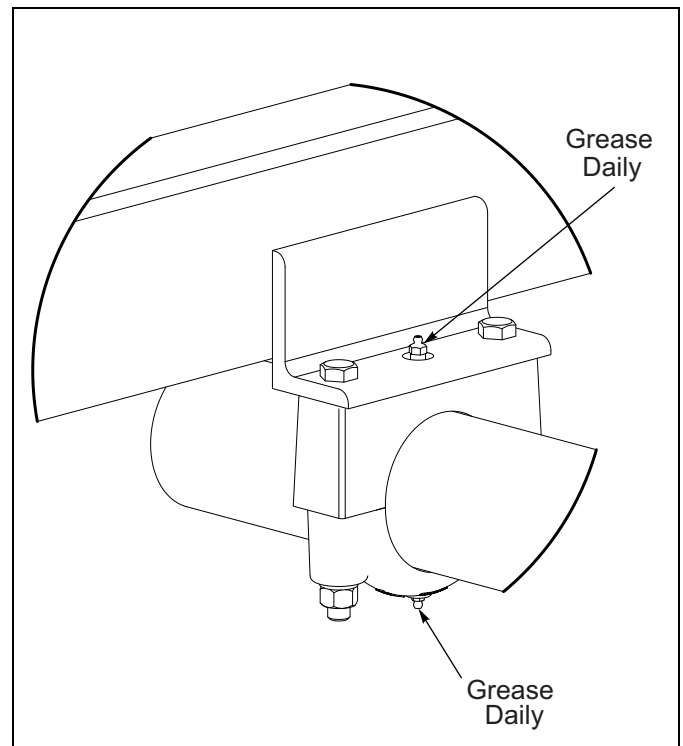

Figure 4-3: Rockshaft Bearings

Hydraulic Maintenance

1. Check the tractor hydraulic fluid level per tractor owners manual and after any leakage. Check fluid level with cylinders in the retracted position.
2. If a cylinder or valve leaks, disassemble the parts to determine the cause of the leak. Any time a cylinder is opened up, or whenever any seal replacement is necessary, it is advisable to clean all parts and replace all seals. Seal kits are available from your Brillion dealer.
3. Check all hydraulic hoses weekly. Look for binding or cracking. Replace all worn or defective parts immediately.

4. Transport locks are provided to hold the implement in a raised position. **See Figure 3-4.** Do not attempt to perform any service work under the implement without first installing the transport locks. Before servicing any hydraulic component, lower the implement to the ground and relieve all system pressure. If a hydraulic component is disconnected, repaired, or replaced, it will be necessary to purge the system of air before operation. **See Page 3-6** on how to purge the hydraulic systems.

C-Tooth Point Replacement

As the C-tooth point wears, a replacement reversible point is available for installation.

Place the reversible point on the front of the C-tooth, line-up the two bolt holes, insert two 3/8-16 X 1-3/4 Cultivator Bolts and tighten using two 3/8-16 Lock Nuts. **See Figure 4-4.**

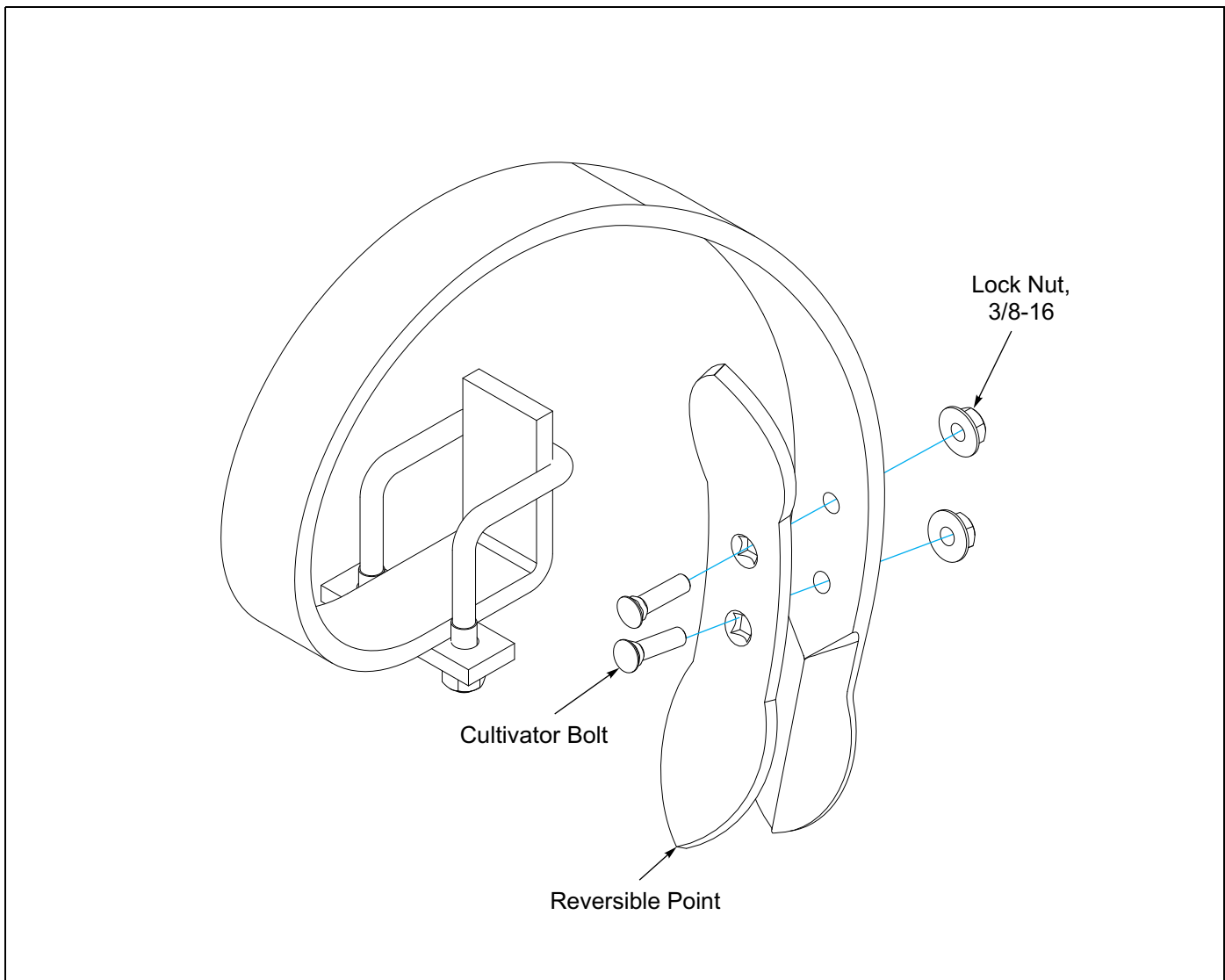

Figure 4-4: C-Tooth Point Replacement

Clamp Tightening Procedure

The tightening procedure and torque requirement is critical in keeping in keeping the clamp tight and also has a significant affect on the bearing life of the axles with internal bearings.

Clamp Tightening Procedure:

Check axle and clamp for burrs on mating surfaces.

Remove end play between wheels by sliding wheels toward the fixed end of the axle.

Position clamp snugly against the end wheel.

Tighten the U-bolt evenly to 57 Ft/Lbs (U-bolt must be tightened first.) **See Figure 4-5.**

Tighten set screws to 37 Ft/Lbs (Some clamps do not have set screws.)

If the axle has an internal bearing, check that it turns freely. You should be able to turn the bearing with your fingers. If rotation is jerky, loosen set screws and U-bolt until bearing turns smoothly. It may be necessary to loosen and reposition clamp.

The torque requirement is recommended for axles without internal bearings, but is not critical.

Axle Installation:

When installing a roller axle with an internal bearing onto a support bracket, it is important to keep the roller axle aligned as straight as possible to the installed position. If the roller assembly is significantly out of line when sliding it unto a fixed support, the inner race of the bearing may crack and cause premature bearing failure.

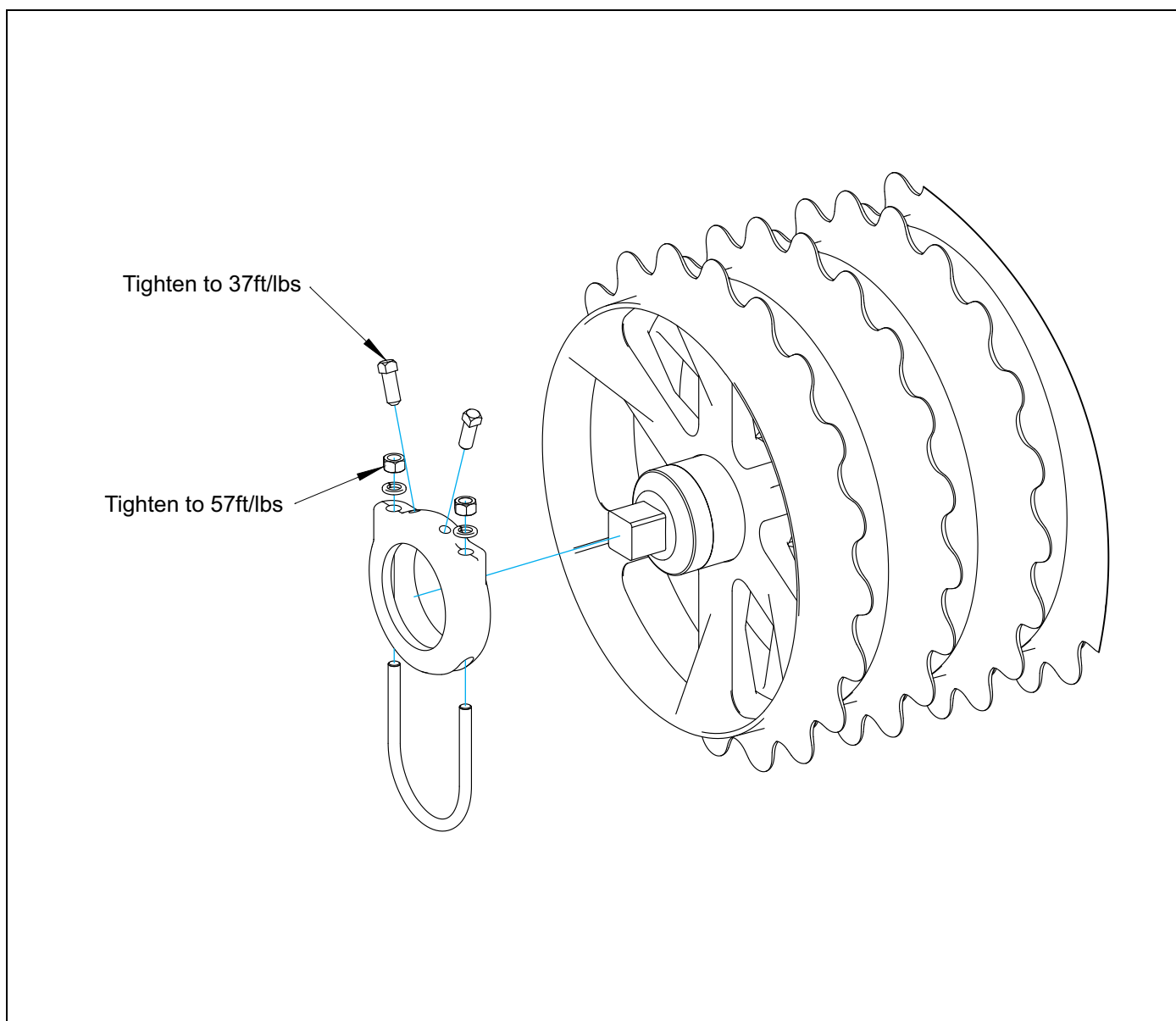

Figure 4-5: Clamp Tightening

Storage

1. The service life of the Pulvi-Mulcher will be extended by proper off-season storage practices. Prior to storing the unit, complete the following procedures:
 - a. Completely clean the unit.
 - b. Inspect the machine for worn or defective parts. Replace as needed.
 - c. Repaint all areas where the original paint is worn off.
 - d. Grease all exposed metal surfaces of shanks and points.
 - e. Apply a light coating of oil or grease to exposed cylinder rods to prevent them from rusting.
2. Store the unit in a shed or under a tarpaulin to protect it from the weather. The ground tools and tires should rest on boards, or some other object, to keep them out of the soil.
3. If the unit is stored in the folded position, make sure the transport lock pins are installed to prevent settling.
4. Relieve Hydraulic Pressure in hoses after locks are installed.
5. Block wheels before unhitching from tractor.

General Reference and Specifications

	ML-2253	MCL-2253	MLC-2253	MCC-2253
Approximate Weight	7,201 lbs. (3,240 kg)	7,138 lbs. (3,212 kg)	6,988 lbs. (3,145 kg)	6,924 lbs. (3,116 kg)
Working Width	18 ft. 9 in. (5.63 m)	18 ft. 9 in. (5.63 m)	18 ft. 9 in. (5.63 m)	18 ft. 9 in. (5.63 m)
Transport Width	19 ft. 6 in. (5.85 m)	19 ft. 6 in. (5.85 m)	19 ft. 6 in. (5.85 m)	19 ft. 6 in. (5.85 m)
Transport Height	3 ft. 8 in. (1.1 m)	3 ft. 8 in. (1.1 m)	3 ft. 8 in. (1.1 m)	3 ft. 8 in. (1.1 m)
Overall Length Transport	19 ft. 10 in. (5.95 m)	19 ft. 10 in. (5.95 m)	19 ft. 10 in. (5.95 m)	19 ft. 10 in. (5.95 m)
Pulverizer Wheels Front	20 in. (500 mm) Notched Ductile Iron	20 in. (500 mm) Notched Ductile Iron	20 in. (500 mm) Notched Ductile Iron	20 in. (500 mm) Notched Ductile Iron
Number of Wheels	54	36	54	36
Pulverizer Wheels Rear	20 in. (500 mm) Notched Ductile Iron	20 in. (500 mm) Notched Ductile Iron	20 in. (500 mm) Crowfoot Ductile Iron	20 in. (500 mm) Crowfoot Ductile Iron
Number of Wheels	55	55	37	37
Rear Roller Scrapers	Standard	Standard	NA	NA
Roller Axle Size	4 in. (102 mm)	4 in. (102 mm)	4 in. (102 mm)	4 in. (102 mm)
Type of Teeth	Conventional "C" Teeth	Conventional "C" Teeth	Conventional "C" Teeth	Conventional "C" Teeth
Number of Teeth	35	35	35	35
Nominal Teeth Spacing	6 in. (153 mm)	6 in. (153 mm)	6 in. (153 mm)	6 in. (153 mm)
Tooth Depth Control	Independent Depth Control Cylinders	Independent Depth Control Cylinders	Independent Depth Control Cylinders	Independent Depth Control Cylinders
Maximum Tooth Depth of Operation	6 in. (153 mm)	6 in. (153 mm)	6 in. (153 mm)	6 in. (153 mm)
Hitch	Pull-Type w/Hydraulic Lift	Pull-Type w/Hydraulic Lift	Pull-Type w/Hydraulic Lift	Pull-Type w/Hydraulic Lift
Tire Size	9.5 L x 15-6 Ply Implement Rib (Duals)	9.5 L x 15-6 Ply Implement Rib (Duals)	9.5 L x 15-6 Ply Implement Rib (Duals)	9.5 L x 15-6 Ply Implement Rib (Duals)
Road Clearance	9 in. (229 mm)	9 in. (229 mm)	9 in. (229 mm)	9 in. (229 mm)
LED Warning Lights & SMV Emblem	Standard	Standard	Standard	Standard
Rear Hitch	Optional	Optional	Optional	Optional
Land Leveler Kit	Optional	Optional	Optional	Optional
Front Roller Scraper Kit (Notched Rollers)	Optional	Optional	Optional	Optional
V-Leveler Kit	Optional	Optional	Optional	Optional
Safety Chain Kit	Standard	Standard	Standard	Standard
Independent Hydraulic Tooth Control	Standard	Standard	Standard	Standard
Horsepower Requirements	6 to 8 HP (4.5 to 6 kW) per ft.	6 to 8 HP (4.5 to 6 kW) per ft.	6 to 8 HP (4.5 to 6 kW) per ft.	6 to 8 HP (4.5 to 6 kW) per ft.
Recommended Operating Speed	3 to 6 MPH (5 to 10 km/h)	3 to 6 MPH (5 to 10 km/h)	3 to 6 MPH (5 to 10 km/h)	3 to 6 MPH (5 to 10 km/h)

Figure 5-1: Specifications 1 of 2

GENERAL REFERENCE AND SPECIFICATIONS

	MLS-2253	MCLS-2253	MLCS-2253	MCCS-2253
Approximate Weight	7,035 lbs. (3,166 kg)	6,972 lbs. (3,137 kg)	6,822 lbs. (3,070 kg)	6,758 lbs. (3,041 kg)
Working Width	18 ft. 9 in. (5.63 m)	18 ft. 9 in. (5.63 m)	18 ft. 9 in. (5.63 m)	18 ft. 9 in. (5.63 m)
Transport Width	19 ft. 6 in. (5.85 m)	19 ft. 6 in. (5.85 m)	19 ft. 6 in. (5.85 m)	19 ft. 6 in. (5.85 m)
Transport Height	3 ft. 8 in. (1.1 m)	3 ft. 8 in. (1.1 m)	3 ft. 8 in. (1.1 m)	3 ft. 8 in. (1.1 m)
Overall Length Transport	19 ft. 10 in. (5.95 m)	19 ft. 10 in. (5.95 m)	19 ft. 10 in. (5.95 m)	19 ft. 10 in. (5.95 m)
Pulverizer Wheels Front	20 in. (500 mm) Notched Ductile Iron	20 in. (500 mm) Notched Ductile Iron	20 in. (500 mm) Notched Ductile Iron	20 in. (500 mm) Notched Ductile Iron
Number of Wheels	54	36	54	36
Pulverizer Wheels Rear	20 in. (500 mm) Notched Ductile Iron	20 in. (500 mm) Notched Ductile Iron	20 in. (500 mm) Crowfoot Ductile Iron	20 in. (500 mm) Crowfoot Ductile Iron
Number of Wheels	55	55	37	37
Rear Roller Scrapers	Standard	Standard	NA	NA
Roller Axle Size	4 in. (102 mm)	4 in. (102 mm)	4 in. (102 mm)	4 in. (102 mm)
Type of Teeth	12 mm "S-Tine" Teeth with 2.75 in. (70 mm) Points	12 mm "S-Tine" Teeth with 2.75 in. (70 mm) Points	12 mm "S-Tine" Teeth with 2.75 in. (70 mm) Points	12 mm "S-Tine" Teeth with 2.75 in. (70 mm) Points
Number of Teeth	35	35	35	35
Nominal Teeth Spacing	6 in. (153 mm)	6 in. (153 mm)	6 in. (153 mm)	6 in. (153 mm)
Tooth Depth Control	Independent Depth Control Cylinders	Independent Depth Control Cylinders	Independent Depth Control Cylinders	Independent Depth Control Cylinders
Maximum Tooth Depth of Operation	6 in. (153 mm)	6 in. (153 mm)	6 in. (153 mm)	6 in. (153 mm)
Hitch	Pull-Type w/Hydraulic Lift	Pull-Type w/Hydraulic Lift	Pull-Type w/Hydraulic Lift	Pull-Type w/Hydraulic Lift
Tire Size	9.5 L x 15-6 Ply Implement Rib (Duals)	9.5 L x 15-6 Ply Implement Rib (Duals)	9.5 L x 15-6 Ply Implement Rib (Duals)	9.5 L x 15-6 Ply Implement Rib (Duals)
Road Clearance	9 in. (229 mm)	9 in. (229 mm)	9 in. (229 mm)	9 in. (229 mm)
LED Warning Lights & SMV Emblem	Standard	Standard	Standard	Standard
Rear Hitch	Optional	Optional	Optional	Optional
Land Leveler Kit	Optional	Optional	Optional	Optional
Front Roller Scraper Kit (Notched Rollers)	Optional	NA	Optional	NA
V-Leveler Kit	Optional	Optional	Optional	Optional
Safety Chain Kit	Standard	Standard	Standard	Standard
Independent Hydraulic Tooth Control	Standard	Standard	Standard	Standard
Horsepower Requirements	6 to 8 HP (4.5 to 6 kW) per ft.	6 to 8 HP (4.5 to 6 kW) per ft.	6 to 8 HP (4.5 to 6 kW) per ft.	6 to 8 HP (4.5 to 6 kW) per ft.
Recommended Operating Speed	3 to 6 MPH (5 to 10 km/h)	3 to 6 MPH (5 to 10 km/h)	3 to 6 MPH (5 to 10 km/h)	3 to 6 MPH (5 to 10 km/h)

CL - Crowfoot front wheels, notched rear wheels

CC - Crowfoot front and rear wheels

LC - Notched front wheels, crowfoot rear wheels

Figure 5-2: Specifications 2 of 2

Document Control Revision Log:

Date	Revision	Improvement(s) Description and Comments
		Initial Release
02/2011	1291rev0211	Incorporated New Drawings, Parts and ECN's, Independent Hydraulics. Updated to the Landoll format.
06/2012	1291rev0612	Incorporated New Drawings, New Part Numbers, and Optional Equipment.
06/2013	1291rev0613	Incorporated Improved Drawings.
01/2017	1291rev0117	Added LED Warning Lights



Intertek

Equipment from Landoll Corporation is built to exacting standards ensured by ISO 9001 registration at all Landoll manufacturing facilities.

18' 9" RIGID PULVI-MULCHER

**Models: ML, MLS, MCL, MLC, MCC, MCLS,
MLCS, and MCCS 2253
Operator's Manual**

Re-Order Part Number 1K965rev0117

LANDOLL CORPORATION

1900 North Street

Marysville, Kansas 66508

(785) 562-5381

800-428-5655 ~ WWW.LANDOLL.COM



Copyright 2014. Landoll Corporation

"All rights reserved, including the right to reproduce this material or portions thereof in any form"