

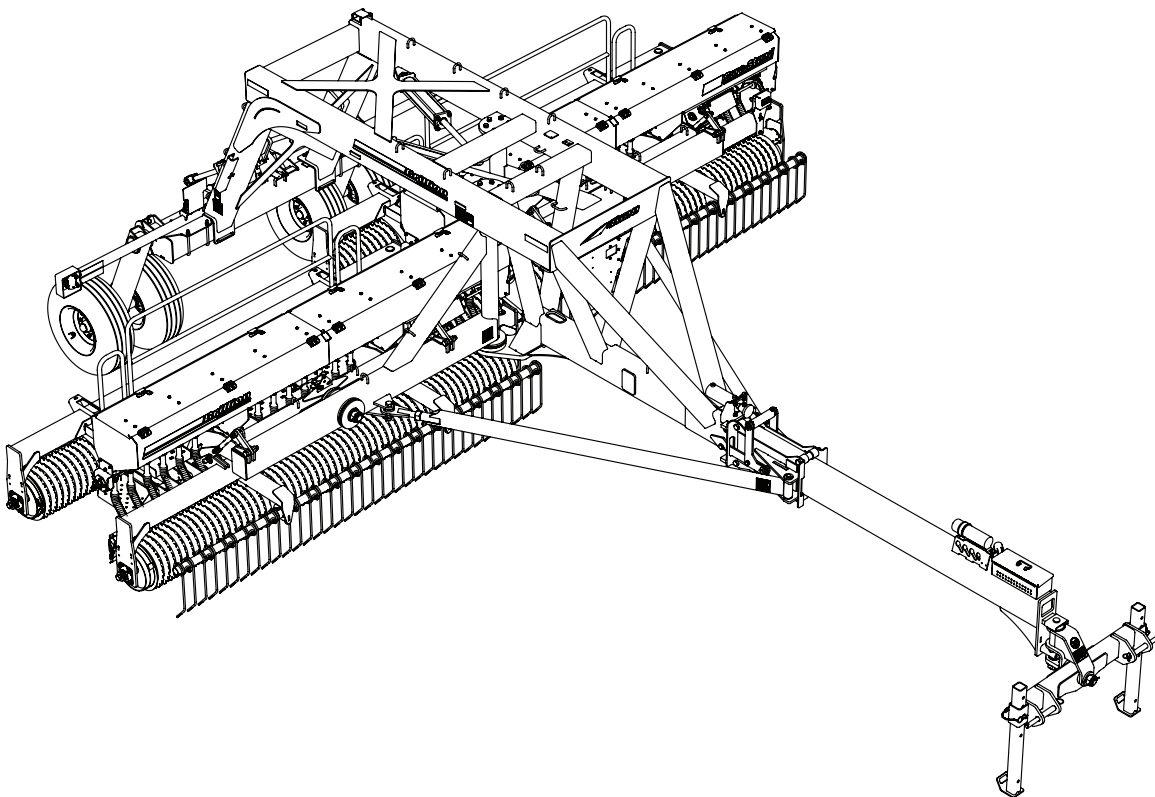

Folding Seeder Model 4620-24 Operator's Manual



LANDOLL COMPANY, LLC

1900 North Street

Marysville, Kansas 66508

(785) 562-5381

800-428-5655 ~ WWW.LANDOLL.COM

Manuals for 4620-24 Folding Seeder

Manual Number	Manual Type
F-886	Operator's Manual
F-885	Parts Manual



DANGER

DO NOT operate or perform any maintenance tasks on this equipment until you have completed the following:

- 1. Receive proper training to operate this equipment safely.**
- 2. Read and understand the operator's manual.**
- 3. Be thoroughly trained on inspection and repair procedures.**

Failure to comply with this warning may result in serious injury or possibly death.

Table of Contents

1 Safety Information

Introduction	1-1
Description of Unit	1-1
Owner Assistance	1-1
Warranty Registration	1-1
Safety	1-2
Understanding Safety Statements	1-2
High Power Magnet	1-2
Transporting Safety	1-3
Safety Instructions for Towing Vehicles	1-3
Attaching, Detaching and Storage	1-3
Maintenance Safety	1-3
Protective Equipment	1-3
Tire Safety	1-3
Chemical Safety	1-4
Prepare for Emergencies	1-4
High Pressure Fluid Safety	1-4
Decals	1-5

2 Assembly

Hydraulic System	2-1
Seeder Undercarriage Assembly to Wing Arm Installation	2-2
Tool Storage	2-3
Brillion Elite Mini Monitor	2-4
Brillion Elite Mini Monitor - Single Seed Box Sensor Schematic	2-5
Brillion Elite Mini Monitor - Seed Shaft Sensor	2-6
Brillion Elite Mini Monitor - Bin Level Sensor	2-7
Brillion Elite Mini Monitor - Ground Speed Sensor	2-8
Console w/Clutch Control Tractor Installation	2-10
LED Warning Lamps Installation	2-12
Coil Tine Harrow Installation	2-14

3 Operation

Tractor Preparation	3-2
Folding Seeder Preparation	3-2
Attaching Folding Seeder to the Tractor	3-2
Detaching the Folding Seeder from Tractor	3-3
Hydraulic System	3-3
Hydraulic Lift System	3-4
Hydraulic Fold and Wing Lock System	3-4
General Operation	3-6
Transport Locks	3-6

Seed Rate Adjustment	3-7
Seed Rate Chart.	3-8
Calibration for Unlisted Seeds	3-9
Clutch Operation.	3-10
Brillion Elite Mini Monitor	3-11
Console w/Clutch Control.	3-11
Coil Tine Harrow.	3-12
Transporting the Folding Seeder	3-13

4 Brillion Elite Mini Monitor

Overview.	4-1
Main Screen Layout	4-1
Speed & Icon Selection	4-1
Field & Total Acres	4-1
Alarms	4-1
Settings Menu - Speed Settings.	4-2
Speed Source	4-2
Speed Source Displays	4-3
Speed Source Icon Features	4-3
Pulses Per Revolution	4-3
Wheel Pulses Per 400FT	4-3
Radar Pulses Per 400FT	4-3
Speed (Simulated Speed)	4-3
Speed Calibration.	4-4
Implement Switch.	4-4
Implement Switch Setup	4-4
Settings Menu - Clutch Setting.	4-4
Settings Menu - Install Setup	4-5
Learn New System.	4-5
Remove A Sensor	4-5
Add A Sensor.	4-5
Settings Menu - Shaft Settings.	4-6
Seed Shaft Settings	4-6
Ground Speed	4-6
Settings Menu - Diagnostics.	4-6
Settings Menu - GPS Settings	4-7
GPS Status	4-7
GPS Baudrate	4-7
GPS Speed Correction.	4-7
Settings Menu - Display Settings	4-7
Brightness	4-7
Volume.	4-7
Units.	4-7
Clock (Date & Time).	4-7
System Update.	4-8

Update App. 4-8
Factory Reset 4-8
Service And Technical Support. 4-8

5 Maintenance

General Torque Specifications 5-1
Hydraulic Fitting Torque Specifications. 5-2
Fasteners 5-2
Tires 5-3
Wheel Hub Bearing Maintenance 5-3
Lubrication Maintenance. 5-3
Hydraulic Maintenance 5-4
Hose Identification. 5-4
Front and Rear Roller Adjustment. 5-4
Roller Clamp Tightening 5-5
Servicing Seed Shaft Assembly 5-5
Seed Meter Adjustment. 5-6
LED Warning Lamps. 5-7
Storage 5-7

6 General Reference and Specifications

Safety Information

Introduction

The implement described in this manual has been designed with care and built by skilled workers using quality materials and processes. Proper assembly and maintenance will provide you with satisfactory use for seasons to come.

DANGER

Read this entire manual before attempting to assemble, adjust or operate this implement. Failure to comply with this warning can result in personal injury or death, damage to the implement or its components and inferior operation.

Description of Unit

The 4620-24 Folding Seeder folds forward for narrow transport width under 14 feet and seeds 24 feet per pass. Each seeder section features a 15-bushel capacity Seed Box with proven Micro-Meter Seed Metering System. The Seeder Wings float 5 degrees left to right and 5 degrees front to rear on torsion springs to follow the ground's contours. The Seeder Sections are ground driven and are equipped with an electric clutch. The tractor mounted controller allows the operator to control clutch engagement, view planted acreage, and monitor seed shaft rotation along with minimum seed box levels.

Using this Manual

This manual will familiarize you with safety, assembly, operation, adjustment, and maintenance. Read this manual and follow the recommendations to help ensure safe and efficient operation.

- The information in this manual is current at time of printing. Some parts may have changed to assure top performance.
- Location reference: Right and Left designations in this manual are determined by facing the direction the implement will travel during field operation, unless otherwise stated.

Owner Assistance

If customer service or repairs are needed, contact your Brillion dealer. They have trained personnel, parts and service equipment specially designed for Brillion products. Your implement's parts should only be replaced with Brillion parts. If items covered in this manual are not understood, contact your local Brillion Dealer.

Warranty Registration

Brillion Farm Equipment, by Landoll, shall have no warranty obligation unless each product is registered within 10 days of retail purchase, using the Landoll Company, LLC Ag Products on-line registration process. Please refer to the Ag Products Policy and Procedures Manual, accessible at www.landoll.com for step by step instructions regarding product registration.

Enter your product information below for quick reference.

MODEL NUMBER

SERIAL NUMBER

DATE OF PURCHASE

Refer to the ID plate shown below. **See Figure 1-1.**

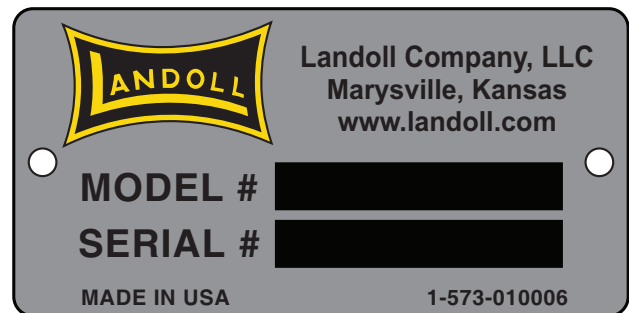

Figure 1-1: ID Plate

SAFETY INFORMATION

Safety

NOTE

Investigation has shown that nearly 1/3 of all farm accidents are caused by careless use of machinery. Insist that all people working with you or for you abide by all safety instructions.

Understanding Safety Statements

You will find various types of safety information on the following pages and on the implement decals (signs) attached to the implement. This section explains their meaning.

NOTICE

Special notice - read and thoroughly understand.

 **CAUTION**

Proceed with caution. Failure to heed caution may cause injury to person or damage product.

 **WARNING**

Proceed with caution. Failure to heed warning will cause injury to person or damage product.

 **DANGER**

Proceed with extreme caution. Failure to heed notice will cause injury or death to person and/or damage product.

NOTE

You should read and understand the information contained in this manual and on the implement decals before you attempt to operate or maintain this equipment.

- Examine safety decals and be sure you have the correct safety decals for the implement. **See Figure 1-2.**
- Order replacement decals through your Brillion dealer.
- Keep these signs clean so they can be observed readily. It is important to keep these decals cleaned more frequently than the implement. Wash with soap and water or a cleaning solution as required.
- Replace decals that become damaged or lost. Also, be sure that any new implement components installed during repair include decals which are assigned to them by the manufacturer.

- When applying decals to the implement, be sure to clean the surface to remove any dirt or residue. Where possible, sign placement should protect the sign from abrasion, damage, or obstruction from mud, dirt, oil etc.

 **DANGER**

- **Do not allow anyone to ride on the tractor or implement. Riders could be struck by foreign objects or thrown from the implement.**
- **Never allow children to operate equipment.**
- **Keep bystanders away from implement during operation.**

High Power Magnet

The Brillion Elite Mini Monitor uses very powerful Neodymium Magnets. Read all the warnings before operating the machine.

 **WARNING**

1. **Neodymium Magnets are brittle; they can be broken or can splinter in a collision. One should wear gloves and protective glasses when handling these magnets, because splinters and/or spacers could disengage and fly from the magnets.**
2. **Normal Neodymium Magnets will lose their magnetic properties if heated above 175°F (80° C).**
3. **The strong magnetic fields of Neodymium Magnets can damage items such as televisions, computer monitors, credit cards, bank cards, computers, diskettes and other data carriers, video tapes, mechanical watches, hearing aides, loud speakers and VCRs. Pace-Makers may be damaged or switch to "Test Mode" in the presence of a strong magnetic force, if a Pace-Maker or other electrical body implant is in use, Keep a Minimum of 3 Feet Distance.**
4. **Children should not be allowed to handle Neodymium Magnets as they can be dangerous. Small magnets pose a choking hazard and should never be swallowed or inserted into any part of the body.**
5. **Under no circumstances should you try to cut, saw or drill the Neodymium Magnet! Not only would the magnet break, but the resulting dust from the magnet is very flammable. Neodymium Magnets should never be burned, as burning them will create toxic fumes.**

Transporting Safety

IMPORTANT

It is the responsibility of the owner/operator to comply with all state and local laws.

- When transporting the implement on a road or highway, use adequate warning symbols, reflectors, lights and slow moving vehicle sign as required. Slow moving tractors and towed implements can create a hazard when driven on public roads. They are difficult to see, especially at night.
- Do not tow an implement that, when fully loaded, weighs more than 1.5 times the weight of the towing vehicle.
- Carry reflectors or flags to mark the tractor and implement in case of breakdown on the road.
- Do not transport at speeds over 20 MPH under good conditions. Never travel at a speed which does not allow adequate control of steering and stopping. Reduce speed if towed load is not equipped with brakes.
- Avoid sudden stops or turns because the weight of the implement may cause the operator to lose control of the tractor. Use a tractor 1.5 times heavier than the implement.
- Use caution when towing behind articulated steering tractors; fast or sharp turns may cause the implement to shift sideways.
- Keep clear of overhead power lines and other obstructions when transporting. Know the transport height and width of your implement. **See Figure 6-1.**

Safety Instructions for Towing Vehicles

The maximum travel speed is the lesser of

- The limit of the road conditions;
- The maximum specified ground speed;
 - for towing operations as indicated in this manual or SIS;
 - of the towed vehicle as indicated in its operator's manual, SIS, or information sign;
- The maximum ground speed of the towed equipment combination shall be limited to the lowest specified ground speed of any of the towed machines. This speed is the ground speed limitation.

EXAMPLE: If the tractor is capable of 25 mph, the first implement has a SIS for 19 mph, and the last implement's operator's manual states its specified ground speed is 15 mph, the towed equipment combination ground speed limitation is 15 mph.

Attaching, Detaching and Storage

- Do not stand between the tractor and implement when attaching or detaching implement unless both are blocked from moving.
- Before applying pressure to the hydraulic system, be sure all connections are tight and that hydraulic hoses are not damaged.
- Block implement so it will not roll when unhitched from the tractor.
- Relieve pressure in hydraulic circuit before uncoupling hydraulic hoses from tractor.

NOTE

To relieve hydraulic pressure: Depending on tractor hydraulic system, some can be relieved by actuating control lever after engine is stopped. If tractor has electric over hydraulic controls, it may be necessary to move the control lever to the float position. Refer to tractor's operator's manual.

Wear protective gloves and safety glasses or goggles when working with hydraulic systems.

Maintenance Safety

- Block the implement so it will not roll when working on or under it to prevent injury.
- Do not make adjustments or lubricate the machine while it is in motion.
- Make sure all moving parts have stopped.
- Understand the procedure before doing the work. Use proper tools and equipment.

Protective Equipment

- Wear protective clothing & equipment appropriate for the job. Avoid loose fitting clothing.
- Because prolonged exposure to loud noise can cause hearing impairment or hearing loss, wear suitable hearing protection, such as earmuffs or earplugs.

Tire Safety

Tire changing can be dangerous and should be performed by trained personnel using correct tools and equipment.

- When inflating tires, use a clip-on chuck and extension hose long enough to allow you to stand to one side, not in front of or over the tire assembly. Use a safety cage if available.
- When removing and installing wheels use wheel-handling equipment adequate for the weight involved.

SAFETY INFORMATION

Chemical Safety

Agricultural chemicals can be dangerous. Improper use can seriously injure persons, animals, plants, soil & property.

- Read chemical manufactures instructions and store or dispose of unused chemicals as specified. Handle chemicals with care & avoid inhaling smoke from any type of chemical fire.
- Store or dispose of unused chemicals as specified by the chemical manufacturer.

Prepare for Emergencies

- Keep a First Aid Kit and Fire Extinguisher handy
- Keep emergency numbers for doctor, ambulance, hospital and fire department near phone.

High Pressure Fluid Safety

Escaping fluid under pressure can be nearly invisible and have enough force to penetrate the skin causing serious injury. Use a piece of cardboard, rather than hands, to search for suspected leaks.

Any fluid injected into the skin must be surgically removed within a few hours or gangrene may result.

Avoid the hazard by relieving pressure before disconnecting hydraulic lines.

NOTE

Relieve hydraulic pressure by shifting the control valve lever to float.

Wear protective gloves and safety glasses or goggles when working with hydraulic systems.

Decals



ITEM 1
2-573-010198

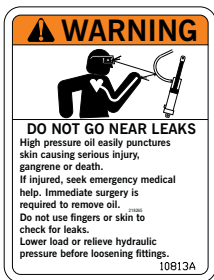

ITEM 4
3K706



ITEM 5
2-573-010335



ITEM 6
528934



ITEM 17
528933



ITEM 18
528938



ITEM 2 - PLACARD



ITEM 9
218288



ITEM 15
2K123

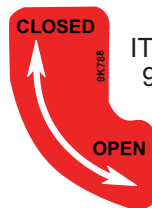

ITEM 13
9K788



ITEM 12 - 155523



ITEM 20 - 9J429



ITEM 7
170509



ITEM 10
203668



ITEM 3
8J309



ITEM 11
144193

CALIBRATION

MACHINE MAY BE CALIBRATED FOR UNLISTED SEED AS FOLLOWS:

- SEED SHAFT TURNS 163 REVOLUTIONS PER ACRE SEEDED.
- RAISE MACHINE AND LOCK IN TRANSPORT POSITION.
- PLACE A CANVAS OR TARP UNDER MACHINE TO CATCH SEED.
- DISengage CLUTCH. TURN SHAFT ON TRANSMISSION SHAFT 163 REVOLUTIONS COUNTER-CLOCKWISE (CCW) WITH PROVIDED CRANK. 41 TURNS MAY BE USED IF RESISTANCE ADJUSTED AS SHOWN IN STEP 5.
- WEIGH SEED FOR APPROXIMATE PLANTING RATE IN LBS/ACRE. MULTIPLY WEIGHT BY 4 IF ONLY 41 TURNS WERE USED.

PLANTING RATES FOR 4620, 15 BU MICROMETER. GROUND DRIVE IN POUNDS PER ACRE

RATES ARE INTENDED AS A GUIDE ONLY. VARIATIONS IN SIZE AND CLEANLINESS WILL AFFECT RATES. CHECK ACREAGE AND POUNDS OF SEED USED FOR BEST RESULTS.

INDICATOR SETTINGS	1A	2A	3A	4A	5A	6A	7A	8A
ALFALFA (UNHAILED)	3	7	13	19	23	29	34	39
BAMA	1	6	10	14	19	23	27	30
BERMUDA (HALLED)	3	7	13	20	24	30	34	40
BROGDOT TRIFOL (BROODLEAF)	3	9	14	20	26	34	44	51
BLUE GRASS (KENTUCKY)	1	3	4	7	9	11	13	14
BLUE GRASS (PAIN KENTUCKY)	1	4	7	11	14	19	21	24
BLUE GRASS (SHERMAN BIG)	0	1	4	6	7	9	10	11
CANOLA	11	7	11	11	21	29	36	38
CENTPEICE	3	7	9	13	17	20	23	26
CLOVER ALFALFA, CALIFORNIA BUR, CRIMSON, HUBBARD	3	7	11	17	24	28	34	43
CRACKED WHEAT	0	1	3	4	6	7	9	10
CROWN VETCH	3	10	16	21	29	34	41	49
FALM	3	7	11	14	19	23	27	30
HACKBERRY GRASS	1	6	9	13	16	20	23	26
KLEIN GRASS	3	7	14	19	26	33	40	44
LESPEDEZA (KOREAN UNHALLED)	1	6	10	14	20	24	30	34
LESPEDEZA (KOREAN HALLED)	3	7	13	20	23	29	36	40
LESPEDEZA (GEORGIA UNHALLED)	1	4	7	11	16	19	21	24
LESPEDEZA (GEORGIA HALLED)	3	9	14	21	24	31	37	44
LOVE GRASS (WEIPEING)	1	9	14	19	24	31	37	44
LOVE GRASS (SAND)	3	9	14	20	26	31	37	44
MILLET	3	9	14	20	26	31	37	44
RED TOP	1	3	6	9	10	13	14	16
RYE/OAT GRASS (ESKANDER AND HALLED)	0	3	6	7	10	13	16	19
TEFF - TIFFANY COATED	4	9	14	20	27	31	38	44
TELAGE RABBIT	3	9	13	19	24	30	35	41
TRICHY	3	6	10	16	20	25	31	36

* WILL CRACK SOME SEEDS AT THESE SETTINGS. NOT RECOMMENDED: LENTILS, SOYBEAN, SOYAB GRASS 21679

CALIBRATION DIAGRAM: 12 TOOTH CLUTCH SHAFT, 30 TOOTH SEEDMETER SHAFT, 218254 CALIBRATION CRANK, ROTATION.

ITEM 8
218279

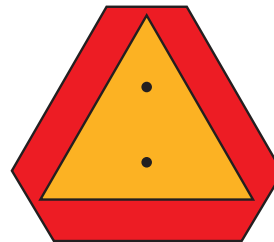

ITEM 14
2P151



ITEM 19
234507



ITEM 16
218260

Figure 1-2: Decals

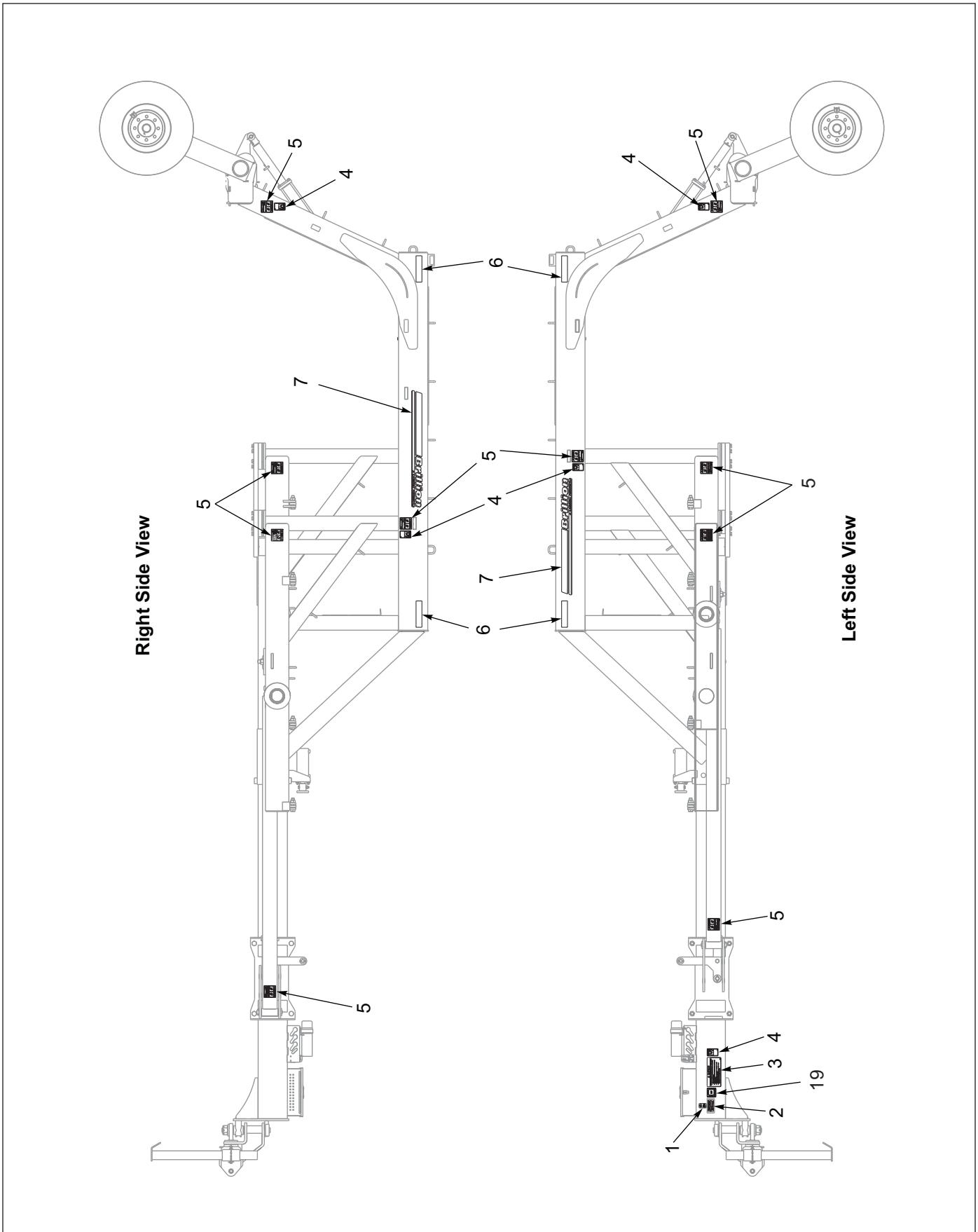

Figure 1-3: Decal Locations (1 of 3)

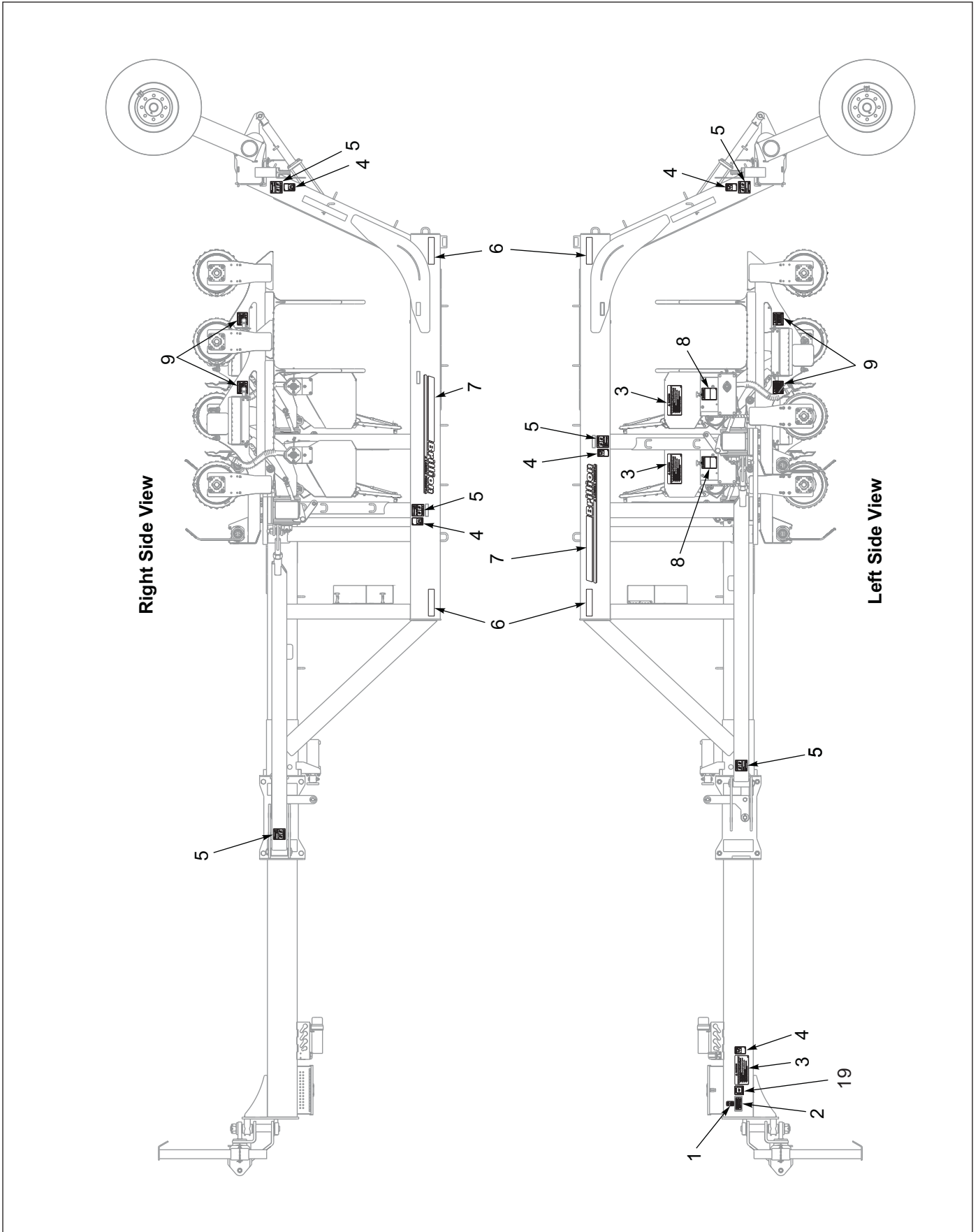

Figure 1-4: Decal Locations (2 of 3)

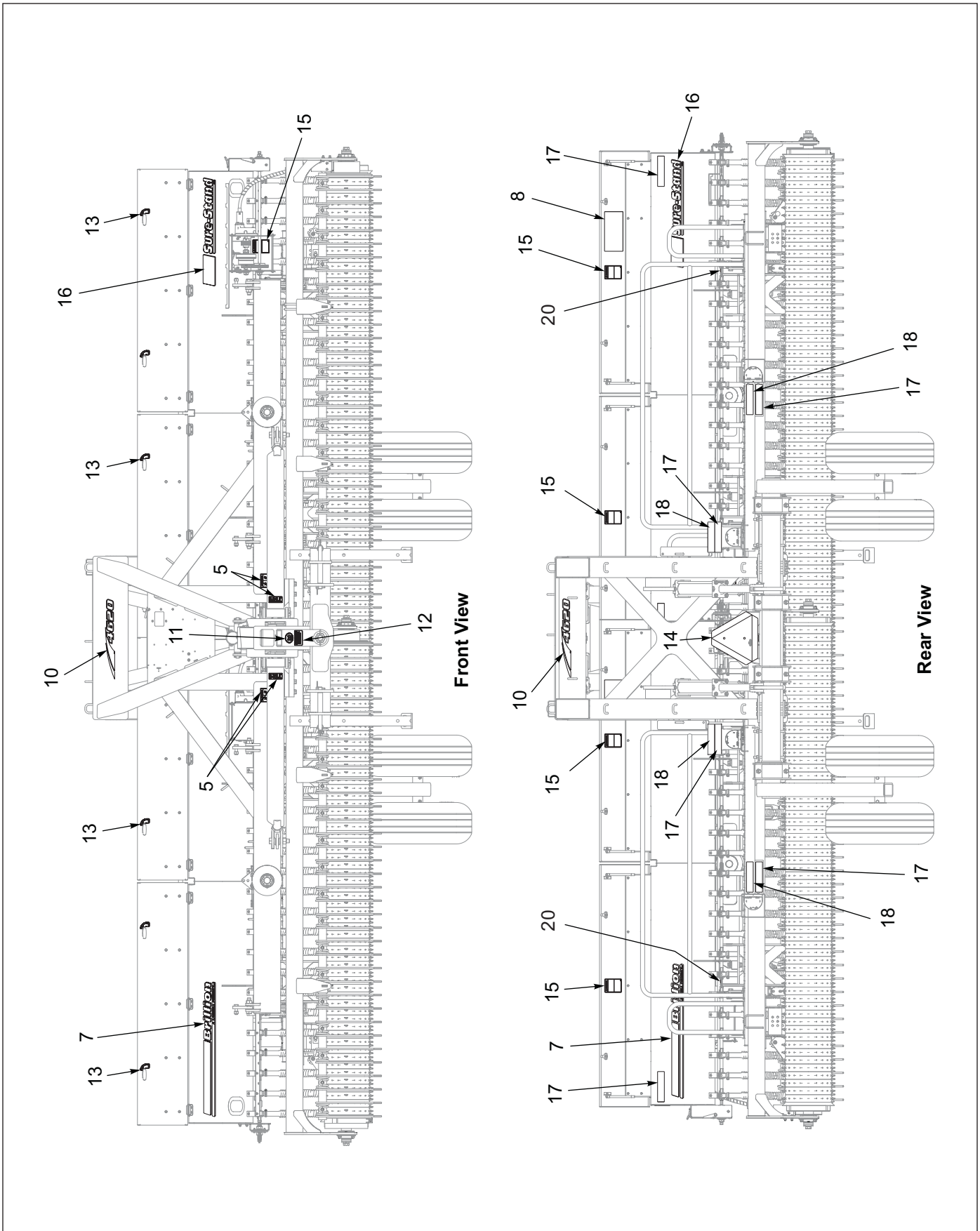

Figure 1-5: Decal Locations (3 of 3)

Assembly

CAUTION

Do not work on or under this machine unless securely blocked and supported by a hoist or tractor or by other sufficient means.

WARNING

Do not attempt to lift heavy parts manually. Use a hoist or a fork lift to move these parts into position.

CAUTION

Secure the Seeder Hitch to a tractor and unfold the wings of the hitch when attaching seeder unit(s). This will provide stability and ease attachment of the seeder unit(s).

The 4620-24 Folding Seeder is almost completely assembled prior to shipping. If some components need removed or adjusted follow the below instructions.

NOTE

Refer to the repair parts manual F-885 for identification of parts and for the approximate relationship of the parts in assembly.

To ensure alignment of assemblies, leave the nuts loose until completion of final assembly. Use lock washers or flat washers as specified. Spread all cotter pins.

After completion of final assembly, tighten all nuts evenly to prevent misalignment, distortion or binding. Tighten all screws and nuts to the recommended torques.

IMPORTANT

- If pre-assembled parts or fasteners are temporarily removed, remember where they go. It is best to keep parts separated.
- Check that all working parts move freely, bolts are tight and cotter pins spread.
- Refer to the Torque Table for proper torque values. Note the different torque requirements for bolts with lock nuts. **See Page 5-1.**

“Left” and “Right” refer to directions seen as if standing behind the machine and facing in the direction of forward travel.

The 4620-24 Folding Seeder Frame comes assembled. Attach a Seeder Undercarriage Assembly to each Wing Arm and connect the Wing Lock Hydraulic Circuit. Install the Brillion Elite Mini Monitor System, Coil Tine Harrows, and Warning Lamp RH and LH Lamp Brackets.

- Prepare Tractor for Operation. **See “Tractor Preparation” on page 3-2.**
- Prepare Folding Seeder. **See “Folding Seeder Preparation” on page 3-2.**
- Attach Folding Seeder to Tractor. **See “Attaching Folding Seeder to the Tractor” on page 3-2.**

Hydraulic System

NOTE

It is good practice to purge the Hydraulic System before installing the Seeder Undercarriage Assemblies onto the Folding Seeder Frame Wing Arms to ensure that the circuits are functioning properly.

4620-24 hydraulic system consists of 3 separate circuits.

Lift Circuit – Blue

- Folding Seeder raised requires approximately **2.3 gallons hydraulic oil**
- Folding Seeder lowered requires approximately **2.0 gallons hydraulic oil**

Fold/Unfold Circuit – Yellow

- Folding Seeder Folded requires approximately **2.3 gallon hydraulic oil**
- Folding Seeder Unfolded requires approximately **2.7 gallons hydraulic oil**

Wing Lock Circuit – Black

- Wing Lock engaged/disengaged requires approximately **1.1 gallons hydraulic oil**

Tightening Procedure for JIC 37 degree Swivel Female Nuts.

1. Check Fitting Flare and seat for defects.
2. Lubricate the connection.
3. Install Hydraulic Hoses without twists.
4. Hand Tighten until connections bottoms.
5. Using 2 wrenches to prevent twisting, rotate the Swivel Nut 2 wrench flats (1/3 turn).
6. For reassembly, follow the same procedure but tighten only 1 wrench flat (1/16 turn).

Tightening Procedure for Swivel O-Ring Fittings.

1. Lubricate O-Ring and install the Fitting until the Metal Washer which backs up the O-Ring contacts the face of the boss.
2. Orient the Fitting by turning counterclockwise up to 1 turn.
3. Tighten the Locknut using 50-60 Ft-Lbs of torque. See **“Hydraulic Fitting Torque Specifications”** on page 5-2.

Seeder Undercarriage Assembly to Wing Arm Installation



WARNING

Do not attempt to lift heavy parts manually. Use a hoist or a fork lift to move these parts into position.

1. With Wing Arms partially unfolded, to clear the folding seeder frame, position a Seeder Undercarriage Assembly behind each Wing Arm. Align the mounting hole on the undercarriage with the Wing Arm mounting hole. **See Figure 2-3.**
2. Place 1/2" Nylon Thrust Washer onto Spindle Carrier and insert into Wing Arm. Place 3/4" Nylon Thrust Washer between Wing Arm and Undercarriage Frame and onto the Spindle Carrier.
3. Slide Seeder Undercarriage onto the Spindle Carrier.
4. Insert the Threaded Pin through the Spindle Carrier. Install Slotted Nut onto the Threaded Pin. Do Not tighten.
5. Connect Pivot Lock Links to the Seeder Undercarriage Assembly Tie Rods with 3/4-10 x 2-1/2 Bolts and secure with Locknuts.
6. Tighten Slotted Nut using 3" Hex Wrench, align holes on Threaded Pin. Insert 3/8-16 x 3-3/4 Bolt with Flat Washer secure with Flanged Locknut.
7. Connect the Left and Right Hand Wing Hydraulic Hoses to the Bulkhead Tee. **See Figure 2-1.**

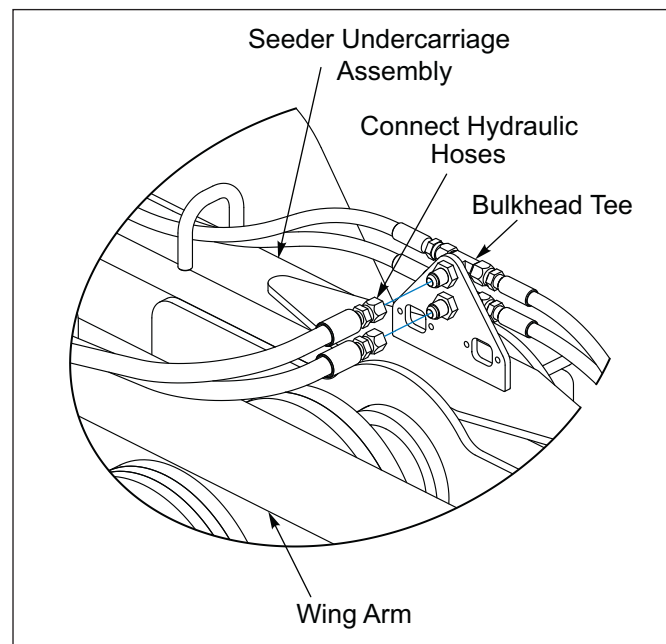

Figure 2-1: Wing Hydraulic Connection

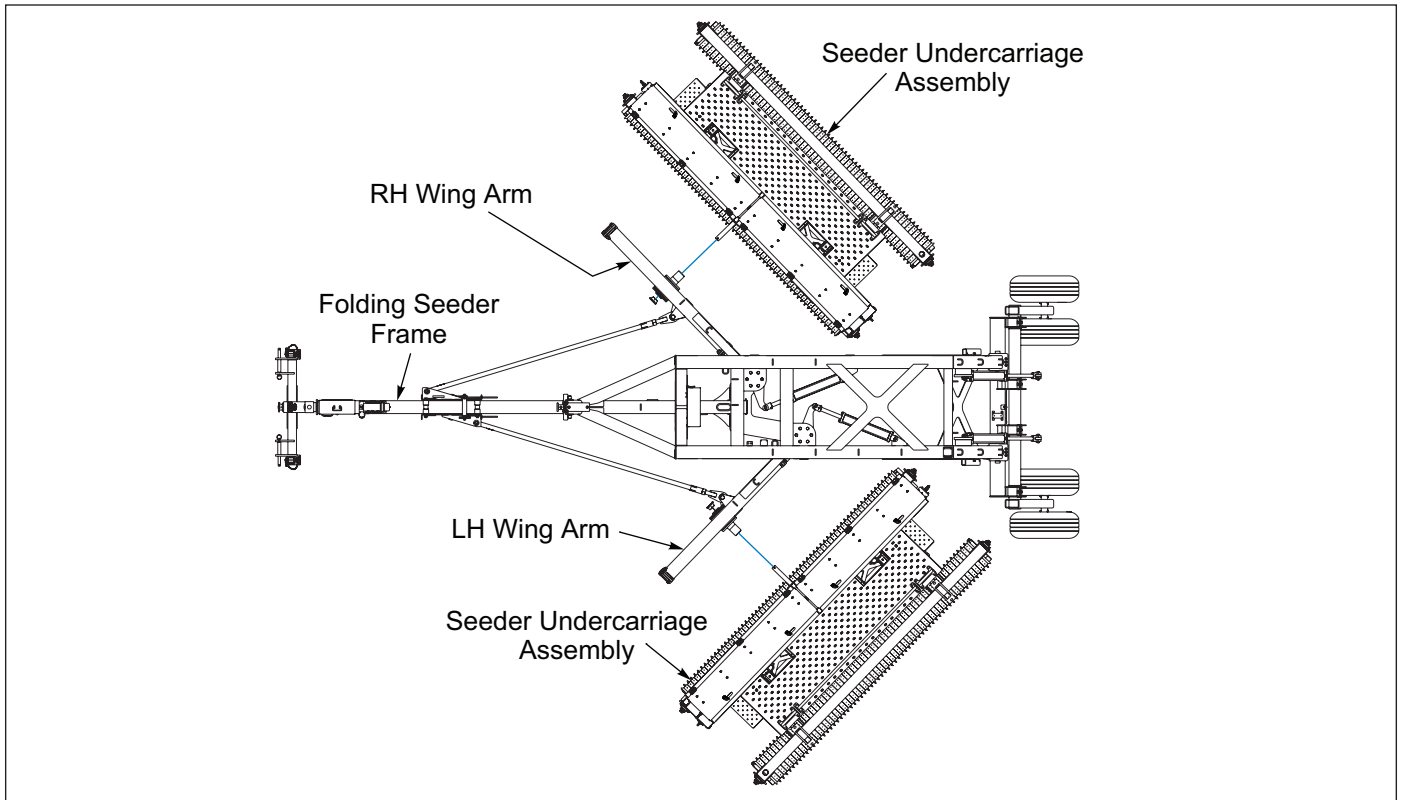

Figure 2-2: Wing Arm Assembly, Top View

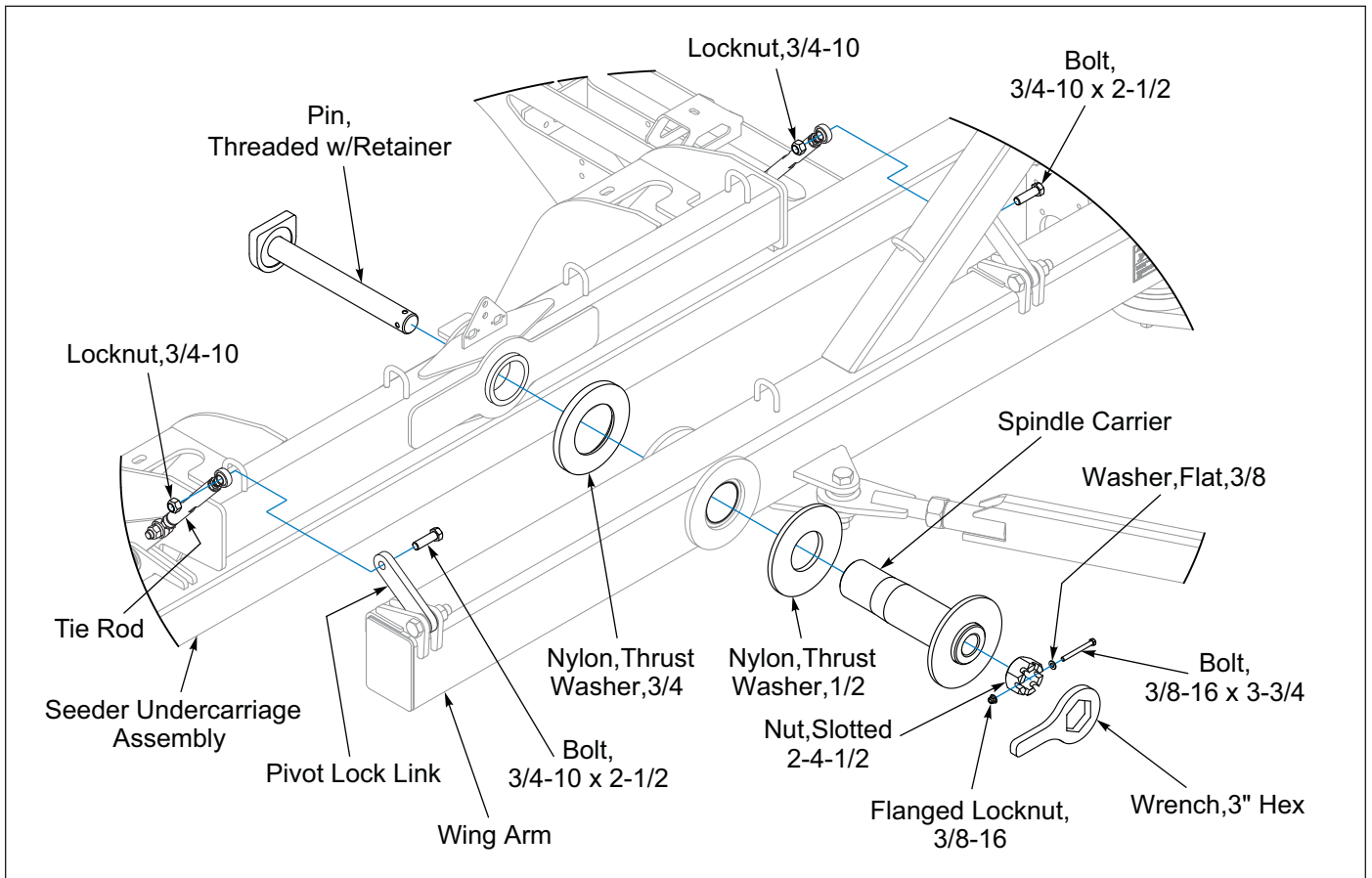

Figure 2-3: Seeder Undercarriage Assembly to Wing Arms

Brillion Elite Mini Monitor

IMPORTANT

The Brillion Elite Mini Monitor System by Loup utilizes a MUX communication line. Sensors must be learned into the Monitor. Location of each pre-learned Smart Shaft Sensor or Bin Level Sensor is important for proper Monitor display. Each Sensor utilizes 3 wires (+, -, MuxBus) to connect to the system. The Harnesses do not require a specific Sensor connection points. Each Sensor is identified in the Monitor by its own signal.

Refer to Brillion Elite Mini Monitor Single Box Schematic. See Figure 2-5.



WARNING

High Power Magnet in use. See "High Power Magnet" on page 1-2.

IMPORTANT

All Harnesses must be firmly attached to Machine Frame members so they do not sag or become torn loose by field debris.

1. Lay out the Seeder Harnesses on the front of each Seeder section ensuring that the Electric Clutch 2-Pin Connector is on the left side.
2. Rear RH side of each Seeder Section has a Sensor Mount mounted on two Seed Cups. Install a Smart Shaft Sensor to the Sensor Mount with sensor provided hardware and #8-32 Flange Locknuts. Adjust the Smart Shaft Sensor so that it is 1/8" Max away from the pre-assembled Spacer w/Magnet on the Seed Shaft. See Figure 2-6. Connect the Smart Seed Shaft Sensor to the Seeder Harness.
3. Each Seeder Section has a Bin Level Sensor Bracket on the inside at either end. See Figure 2-7. Determine the desired level for the alarm to be indicated on the Brillion Elite Mini Monitor and assemble the Bin Level Sensors to Bin Level Sensor Brackets with sensor provided hardware and #8-32 Flange Locknuts. If more adjustment is needed, the Bin Level Sensor Brackets can also be raised or lowered to the desired seed level. Install Cord Grips from the inside of the Seed Box out and secure with supplied Locknut on the outside of the Seed Box. To get the Sensor Connector outside the Seed Box, feed the terminals through the Cord Grip. Install the terminals into the 3-Pin Shroud labeled "A", "B" and "C" as follows "A" White, "B" Black, "C" Green. Inside the Seed Box, add enough slack to the Bin Level Sensor Cord to allow for future adjustment of the Sensor. Secure the Bin Level Cord by tightening the Cord Grip Compression Nut. Connect both Bin Level

Sensors to the Seeder Harness. See Figure 2-4.

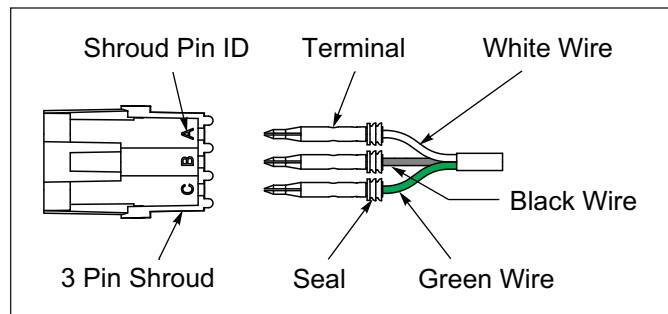

Figure 2-4: Bin Level Sensor Bracket Wire Detail

4. LH Seeder Only, Install Pickup Switch Bracket with the Clutch Shaft Bearing Carriage Bolts, Lock Washer and Nut. See Figure 2-8. Place Actuator Assembly onto the Clutch Shaft, secure with Actuator Assembly Set Screw. Assemble Smart Shaft Sensor onto the Pickup Switch Bracket with sensor provided hardware and #8-32 Flange Locknuts. Adjust the Smart Shaft Sensor so that it is an 1/8" Max away from the Actuator Assembly. Connect the Ground Speed Smart Shaft Sensor to the Seeder Harness.
5. RH Seeder Section does not require a Ground Speed Smart Shaft Sensor, seal RH Seeder Section Seeder Harness Connector with a 3-Pin Shroud and Cavity Plugs to protect the Seeder Harness from the environment.
6. Unused Main Harness 6 Pin Connector and both unused Seeder Harnesses RH 3 Pin Connectors need to be sealed with 6-Pin and 3-Pin Shrouds and Cavity Plugs to protect the Harnesses from the environment.
7. Orient the Main Harness so that the single 6-Pin connector is to the front and the three 6-Pin connectors are to the rear of the Folding Seeder Frame. Route the Main Harness inside the Folding Seeder Frame Main Tube.
8. Install Brillion Elite Mini Monitor on Tractor.
9. If not already installed, install Smart Clutch Relay into Elite Mini Tractor Harness 3-Pin Connectors.
10. Connect the Elite Mini Tractor Harness 14-Pin Connector to Brillion Elite Mini Monitor, 3-Pin Power Plug to 12 Volt Tractor Convenience Outlet and 6-Pin Connector to the Main Harness. 4-Pin Connector is not used at this time.
11. Connect a 240" Extensions Harness to the RH and LH Seeder Harnesses and connect both 240" Extension Harnesses to the Main Harness.
12. Bundle and secure all Harnesses along the Seeder Section Frames and Folding Seeder Frame with Tie Wraps.
13. Program Bin Level Sensors and Smart Shaft Sensors if not already pre-programmed. See "Brillion Elite Mini Monitor" Chapter.

Brillion Elite Mini Monitor - Single Seed Box Sensor Schematic

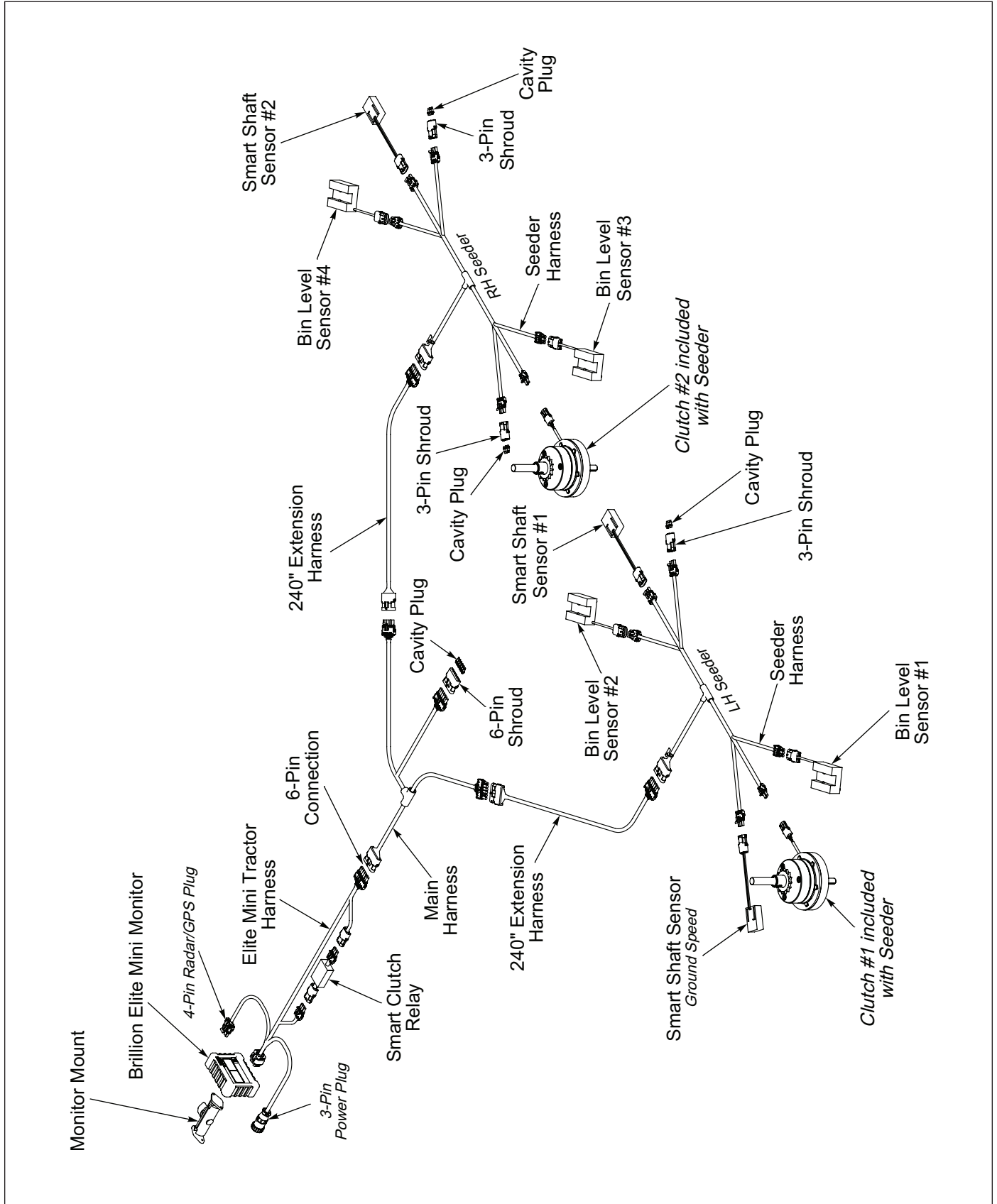

Figure 2-5: Brillion Elite Mini Monitor - Single Seed Box Sensor Schematic

Brillion Elite Mini Monitor - Seed Shaft Sensor

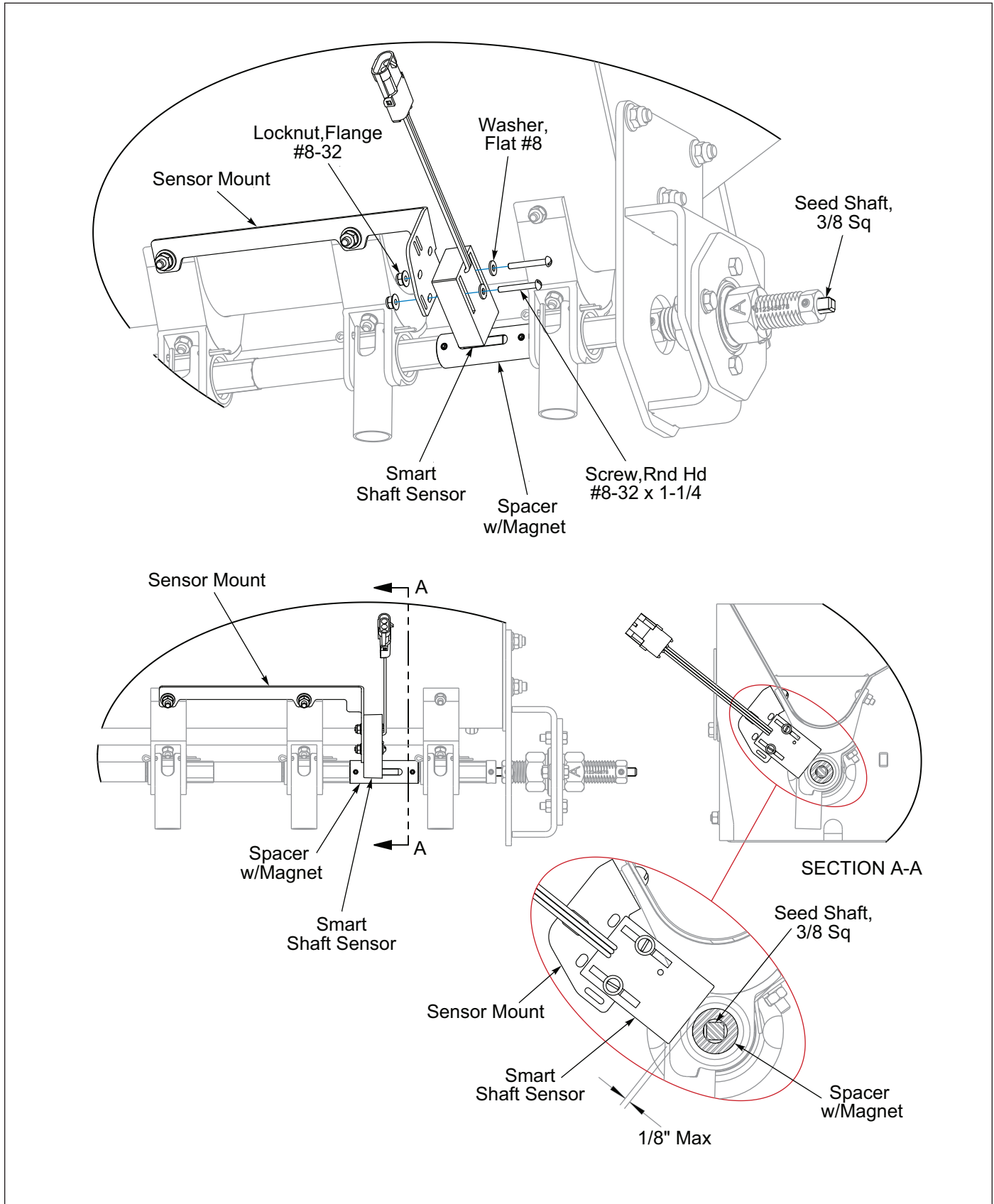

Figure 2-6: Brillion Elite Mini Monitor - Seed Shaft Sensor

Brillion Elite Mini Monitor - Bin Level Sensor

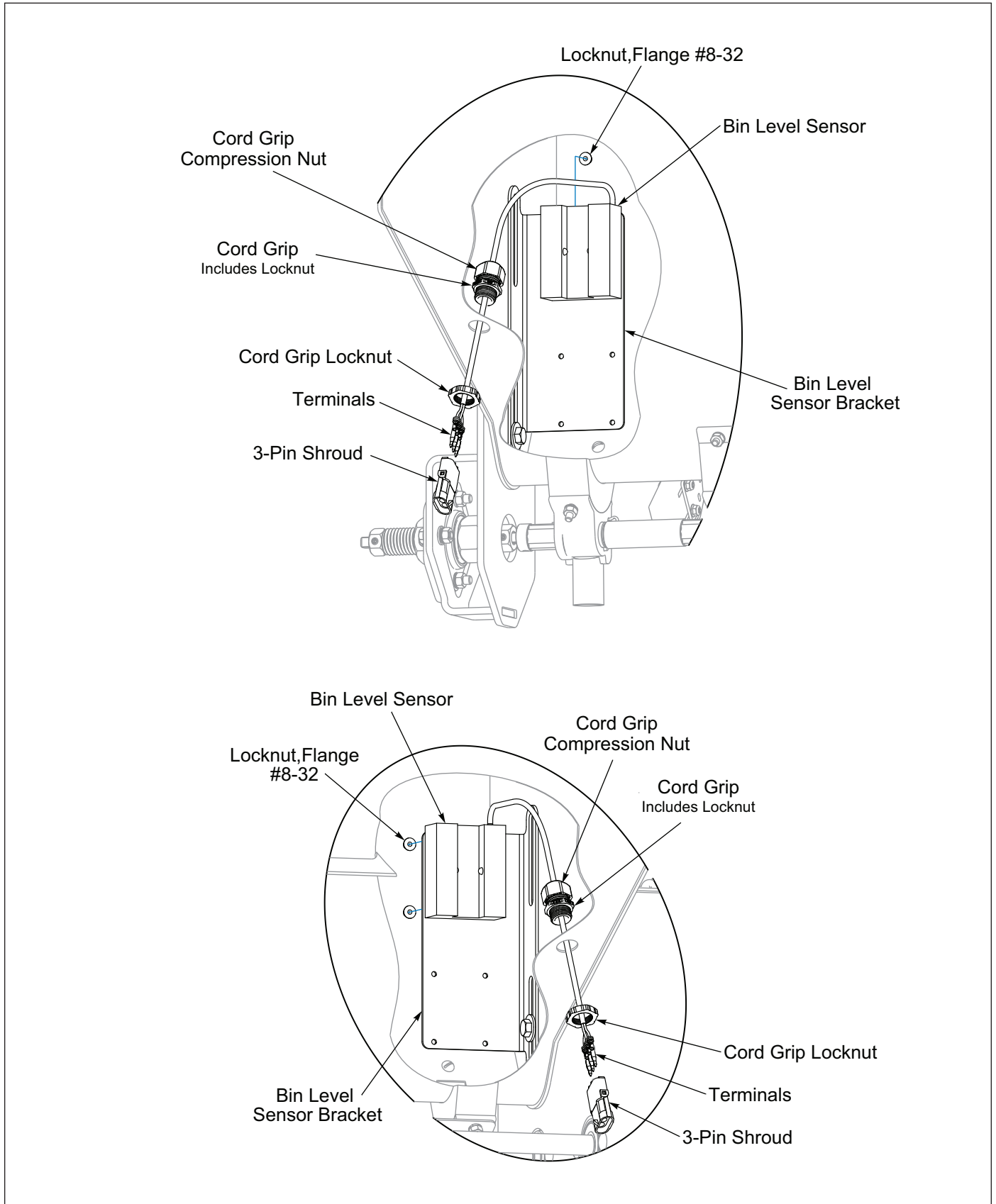

Figure 2-7: Brillion Elite Mini Monitor - Bin Level Sensor

Brillion Elite Mini Monitor - Ground Speed Sensor

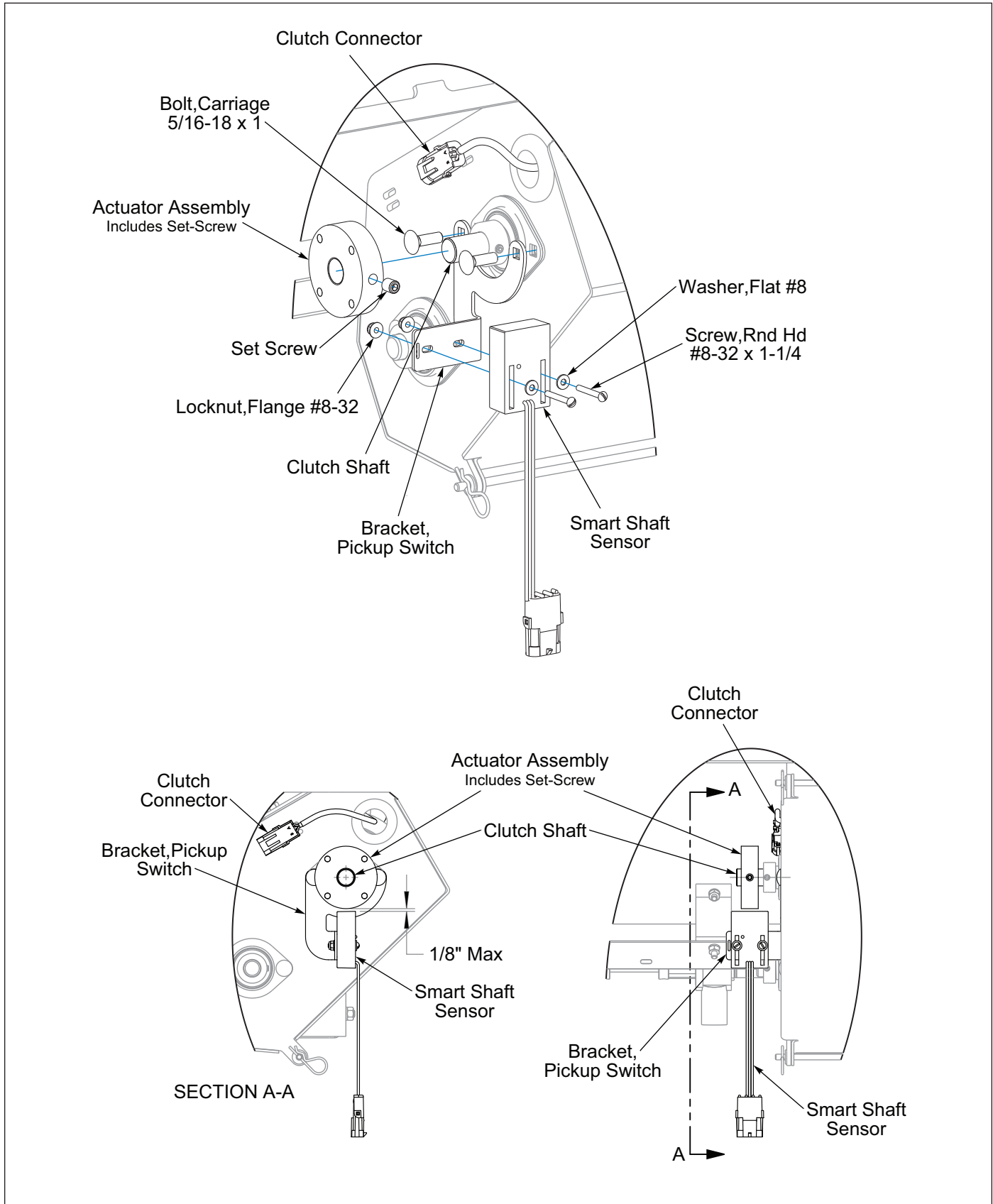

Figure 2-8: Brillion Elite Mini Monitor - Ground Speed Sensor

Console w/Clutch Control Tractor Installation

(Used on models before the Brillion Elite Mini Monitor)

Refer to **Figure 2-10** for Clutch and Seed Shaft Sensor Schematic.

1. Mount Clutch and Seed Shaft Sensor Console Angle Bracket onto Tractor Bracketry where convenient for the operator. **See Figure 2-9.**
2. Attach Straight Bracket to Angle Bracket using 1/2-13 x 1-1/2 Bolt and Flanged Ny-Lok Nut.

3. Attach the Clutch and Seed Shaft Sensor Console to the Straight Bracket with 1/4-20 x 1 Bolt, Flat Washers and Locknut.
4. Plug Clutch and Seed Shaft Sensor Console 3 Pin Power Cable into the Tractor Convenience Outlet and 9 Pin Cable into the Seeder Harness.
5. Secure Console Harness.
6. Check clutch operation: Clutch will engage when power is applied. (Clutch will make a clicking sound). Set seeder on the ground and drive a short distance while turning switch on and off. The seed shaft will stop rotating when switch is turned to "NO SEED" position. **See "Clutch Operation" on page 3-10.**

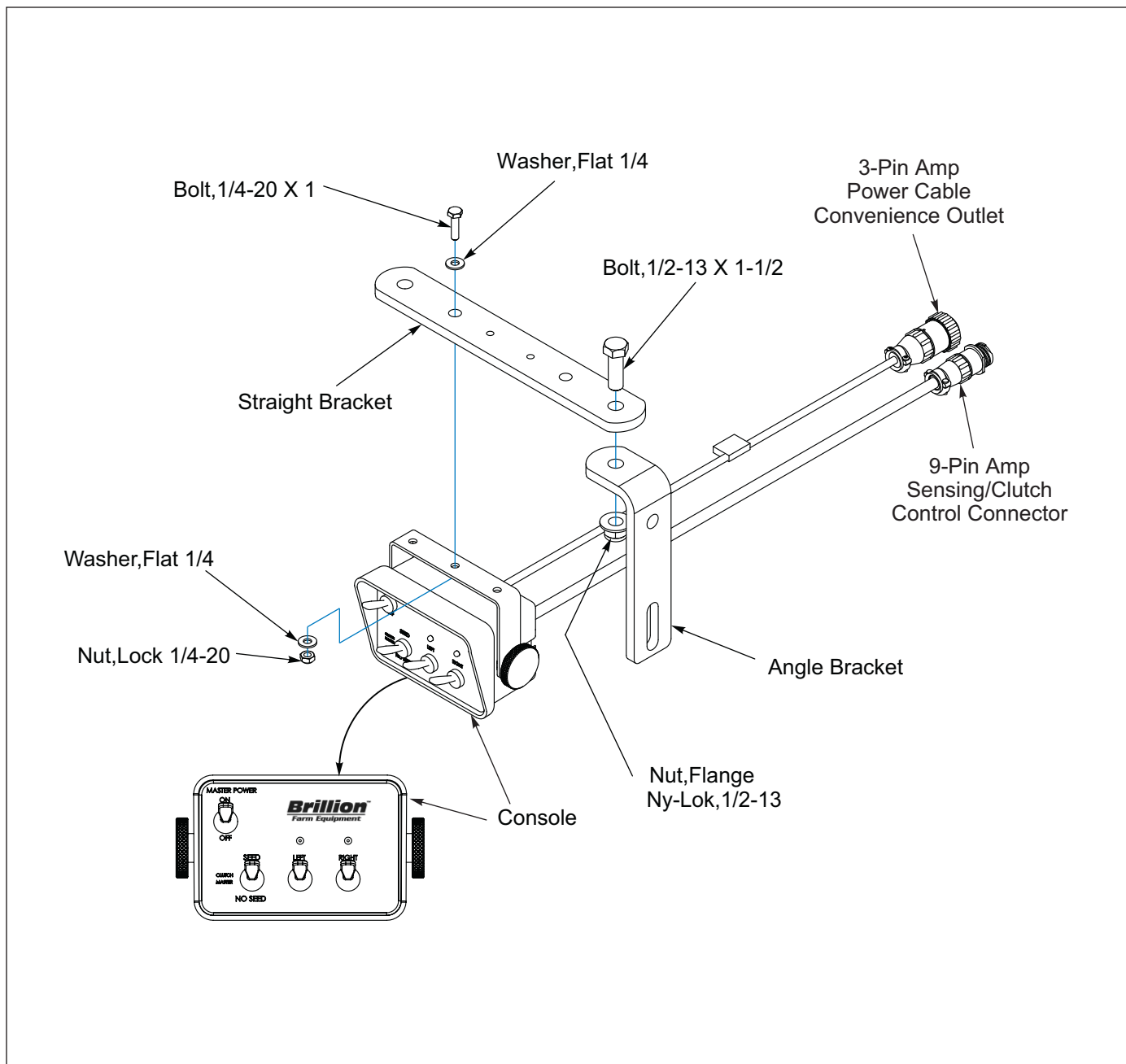

Figure 2-9: Console w/Clutch Control Tractor Installation

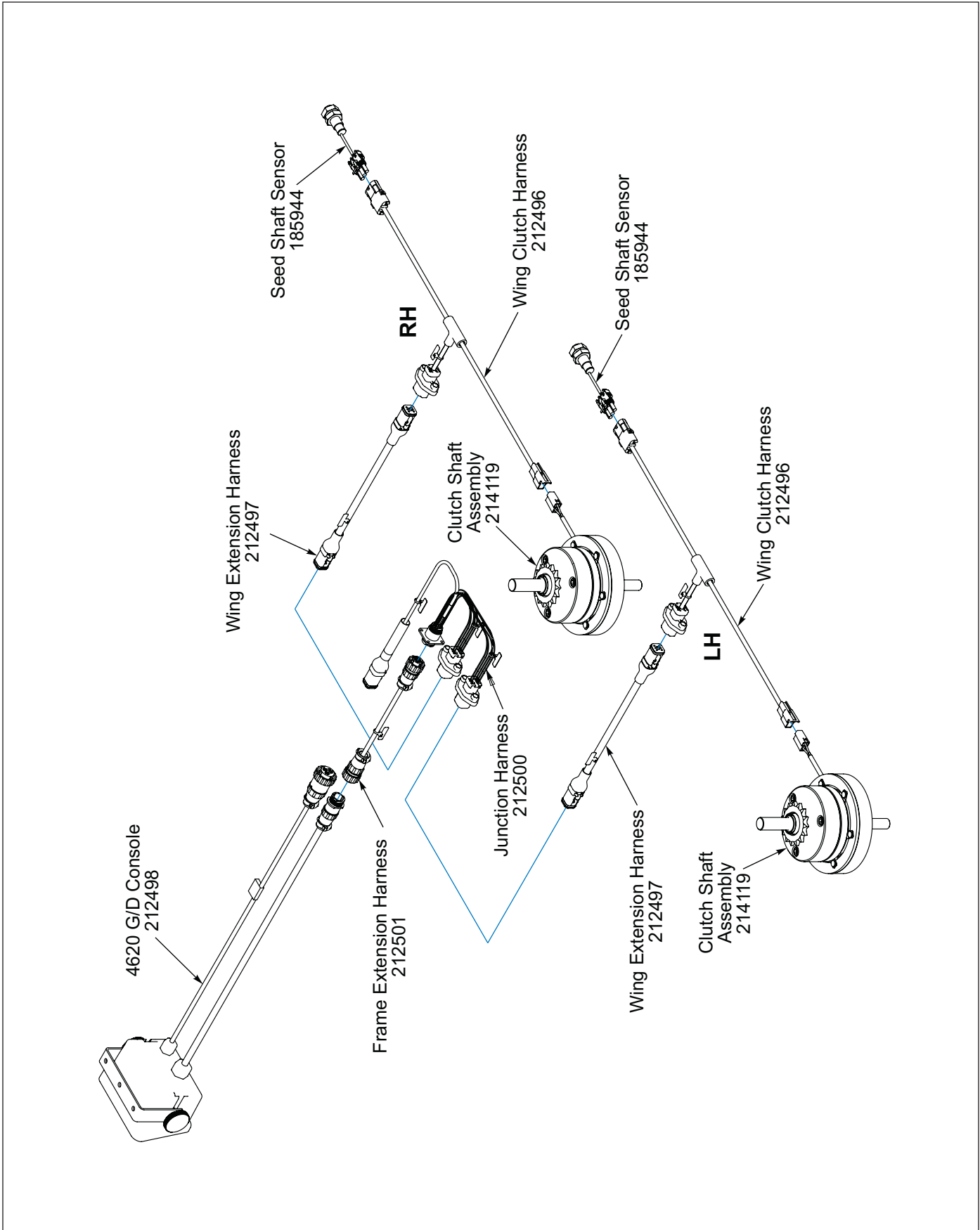

Figure 2-10: Console w/Clutch Control Schematic

Tool Storage

Place the Calibration Crank and Wrenches in the Toolbox. See Figure 2-11.

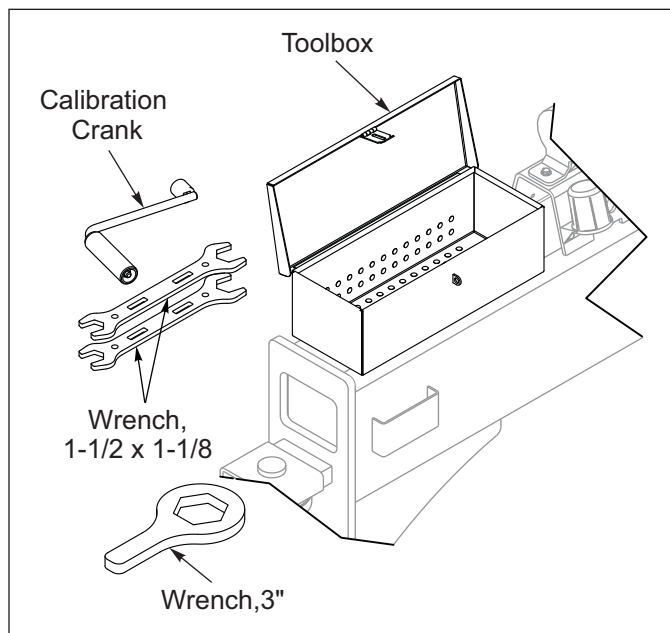

Figure 2-11: Tool Storage

LED Warning Lamps Installation

For shipping, the 4620-24 Folding Seeder has the left and right hand Lamp Brackets removed to reduce transport width.

1. Attach the Left and Right Lamp Brackets with 5/8-11 U-Bolts and Locknuts. See Figure 2-13.

IMPORTANT

Cords are marked Left or Yellow / Right or Green

2. Plug Red Lamps into Warning Lamp Harness Red Connector.
3. Route the RH Amber Lamp Harness Connector through the inside of the RH Lamp Bracket until it protrudes out of the Amber Lamp Mounting Plate. Repeat this step on the LH side.
4. Plug Amber Lamp into Warning Lamp Harness Amber Connector.
5. Ensure when assembling Amber Lamps onto the brackets, that the wires are not pinched when tightening the hardware. Attach Amber Lamps with 1/4-20 x 1-1/2 Bolts, Flat Washers and Locknuts.
6. Bundle and secure any excess cord with tie wraps.

IMPORTANT

All wires must be firmly attached to machine frame members, or air lines, so they don't sag or become torn loose by field debris. Use the cable and hose ties provided.

Check to be sure that wiring at center of machine is slack enough so as not to be stretched or interfered with while rotating frame from transport to field working position and vice versa.

NOTE

The 7-Pin harness connects to the tractor socket when in use. When not in use, it can be stored in the Plug Holder on the frame. See Figure 2-12. Allow enough harness length to reach tractor socket and roll or fold up excess and secure hydraulic hoses.

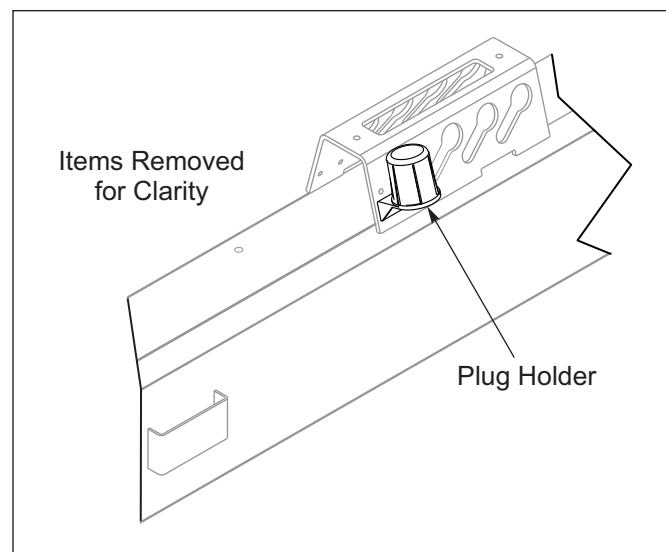

Figure 2-12: Plug Holder

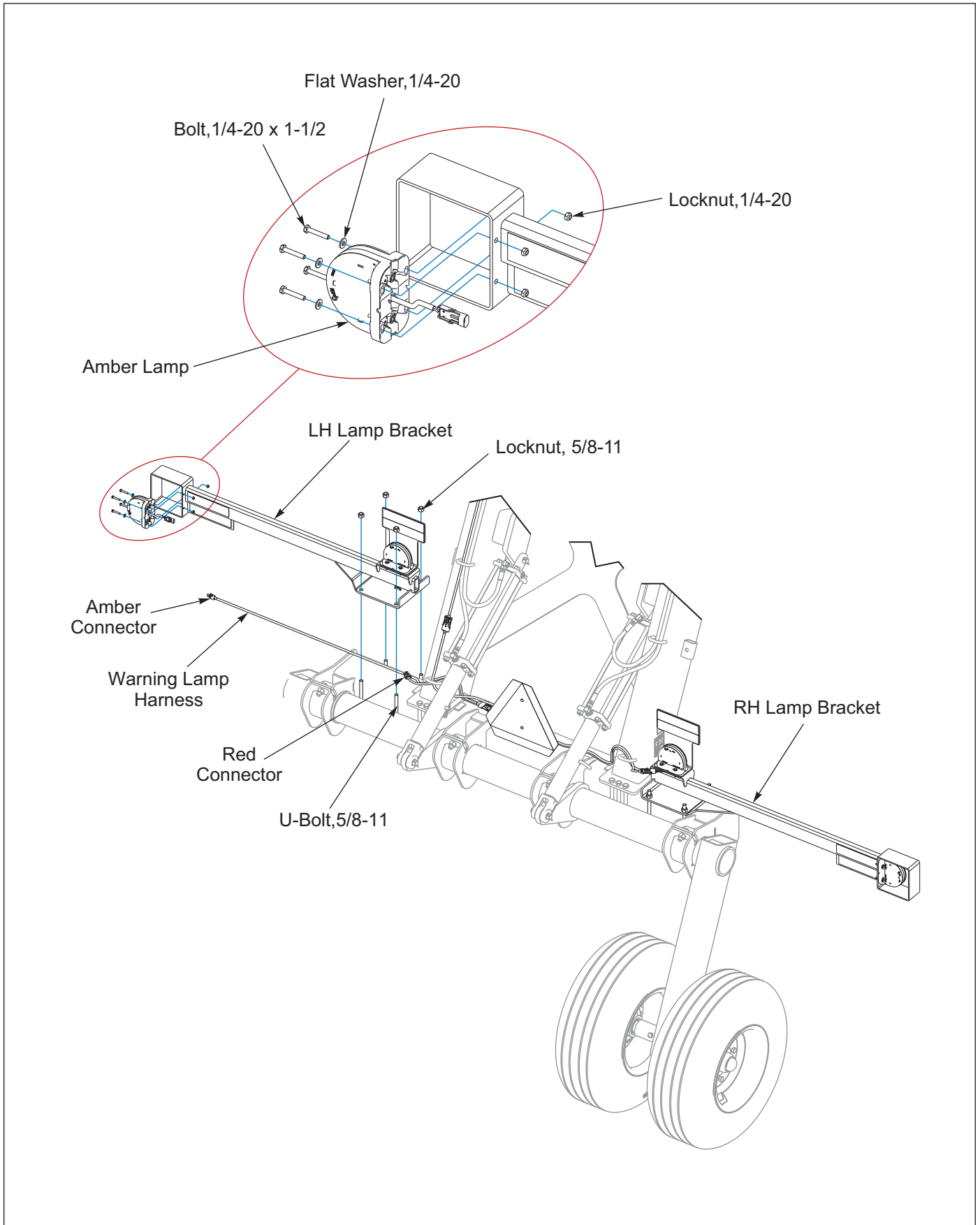

Figure 2-13: LED Warning Lamps Installation

Coil Tine Harrow Installation

1. Attach the Harrow Mounts to the frame using 5/8-11 U-Bolts and Locknuts. See Figure 2-14.
2. Insert the Harrow Assembly into the Harrow Mount. Align the holes and insert 3/8-16 x 1-1/4 Bolts.
3. Start by using the top holes in the Harrow Mount. Adjust as needed. Ensure it's equally spaced from side to side.
4. Repeat for the other side.

⚠ CAUTION

Do not work on or under this machine unless securely blocked and supported by a hoist or tractor or by other sufficient means.

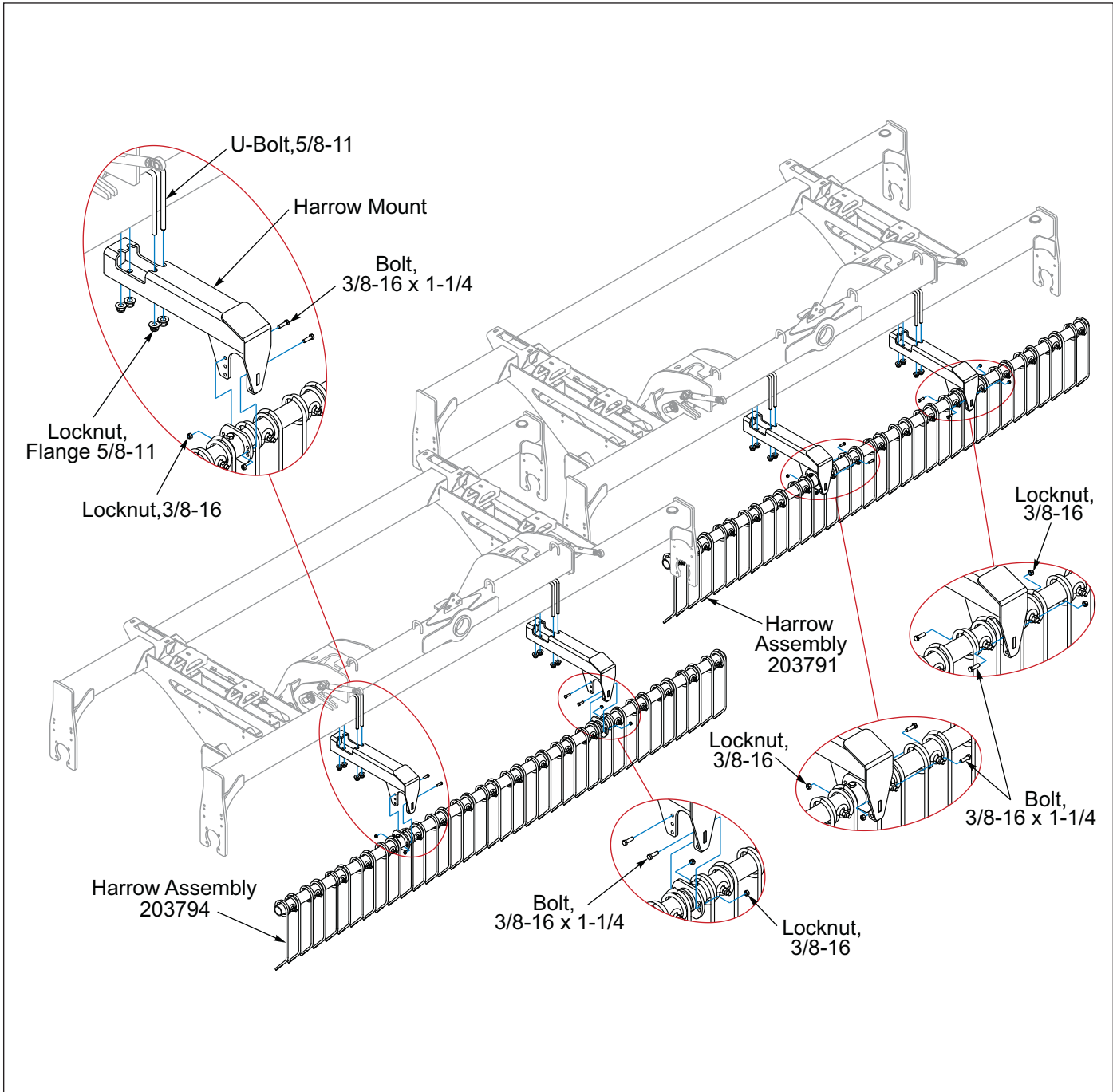

Figure 2-14: Coil Tine Harrow

**DANGER**

Never allow anyone to ride on the 4620-24 Folding Seeder at any time. Allowing a person to ride on the machine can inflict serious personal injury or death to that person.

**DANGER**

Always lock the Tractor Drawbar in the center position when transporting the unit. Failure to do so can result in serious injury or death and cause damage to the machine.

**DANGER**

All hydraulically adjusted equipment must have Transport Locks installed or be lowered to the ground when servicing or when equipment is idle. Failure to take preventive measures against accidental lowering can result in serious personal injury.

**DANGER**

When transporting the unit, place Transport Locks in position after fully extending the Hydraulic Lift Cylinders. Insert Bent Pins to secure the Transport Locks. Failure to use the Transport Locks can cause the unit to settle during transport, which can result in serious injury or death and cause damage to the equipment.

**WARNING**

Keep all bystanders away from the machine when folding/unfolding or transporting.

**CAUTION**

When transporting farm implements on public roads, it is the responsibility of the operator to abide by state and local laws concerning wide loads, speed, safety emblems and safety lighting equipment. Drive at safe speeds, particularly when rounding corners, crossing rough ground or driving on hillsides, to prevent tipping the tractor.

Tractor Preparation

The 4620-24 Folding Seeder is designed to be pulled by a Semi-Mounted Two Point Hitch.

Before attaching the Seeder Hitch, prepare the tractor as follows:

1. The Seeder is designed to be used with Free Link CAT 2, 3; Quick Hitch Coupler CAT 2, 3N, 3. Be sure Tractor's Hitch Capacity is not exceeded by the Laden Mass of the Seeder. **Refer to Tractor Operator's Manual.**
2. Be sure Tractor is properly ballasted. A minimum 25% of Tractor Laden Mass must be on Tractor Front Wheels in transport position to maintain stability. Calculate the Loaded Seeder Mass. **See "General Reference and Specifications" on page 6-1.** (Seeder weight plus the seed box capacity with desired seed.) **Refer to Tractor Operator's Manual.**
3. Inflate the rear tractor tires equally and add ballast according to the tractor operator's manual.

Folding Seeder Preparation

1. Prior to operating the 4620-24 Folding Seeder, read and understand the operator's manual and all decals.
2. Inspect the machine thoroughly for good operating condition.
3. Replace worn or missing parts.
4. When the machine is new, check the bolt tightness after a few hours of operation. Tighten any loose nuts or bolts. Check the lift wheel lug bolts daily.
5. Check the lift wheel tire inflation. Inflate all tires equally to avoid side draft. Follow the tire manufacturer's recommended pressures listed on the sidewall of the tires.
6. Lubricate the machine. **See "Lubrication Maintenance" on page 5-3.**
7. Check that all safety decals and reflectors are correctly located and legible. Replace if damaged.

Attaching Folding Seeder to the Tractor



DANGER

Do not allow any bystanders to stand between the tractor and the implement while backing up to the implement.

1. Carefully back the tractor into position until the hitch is in line with the tractor arms.
2. Back the tractor into final position, and install the hitch pins or lock Quick Hitch if equipped.
3. Connect the Hydraulic Hoses.
4. Fully raise the Seeder and install the Transport Locks over the Hydraulic Lift Cylinders. **See Figure 3-8.**
5. Remove 3/4 inch pins and lift the Parking Stand all the way up. Re-insert pins.
6. Connect the 7-Pin Connector to tractor 7-Pin outlet, routing cable by avoiding pinch points.
 - Make sure the tractor has a good clean receptacle, free of dirt and corrosion.
 - Make sure the 7-Pin Connector is inserted ALL the way in. With tighter fitting pins, operator may think the connector is all the way in, but really isn't.
 - Make sure the tractor receptacle cover latches over the keyway on the 7-Pin Connector to hold the connector in place.
 - If an operator plugs in the 7-Pin Connector, but the lights do not seem to work right, check the above items to make sure there is a good connection with the 7-Pin connector. **See "LED Warning Lamps" on page 5-7.**
7. Join the Brillion Elite Mini Monitor to the Folding Seeder. Connect the 6-Pin connection of Elite Mini Tractor Harness and the Seeder Main Harness at the front of the Folding Seeder Hitch. **See Figure 2-5.**
8. Adjust or lock tractor sway stabilizers if equipped, centering the Seeder with the Tractor. **Refer to the Tractor Operator's Manual.**

Detaching the Folding Seeder from Tractor

When unhitching the Folding Seeder from the tractor, park the seeder on a level area to prevent rolling and shifting.

1. Fully raise the seeder extending the lift cylinders. Fully raise tractor 3-PT Hitch. Install Transport Locks. **See Figure 3-8.**
2. Lower the Front Parking Jack Stands and Pin in the parking position. **See Figure 3-1.** If storing on soft ground, place boards or plates under the Jack Stands for a larger foot print.

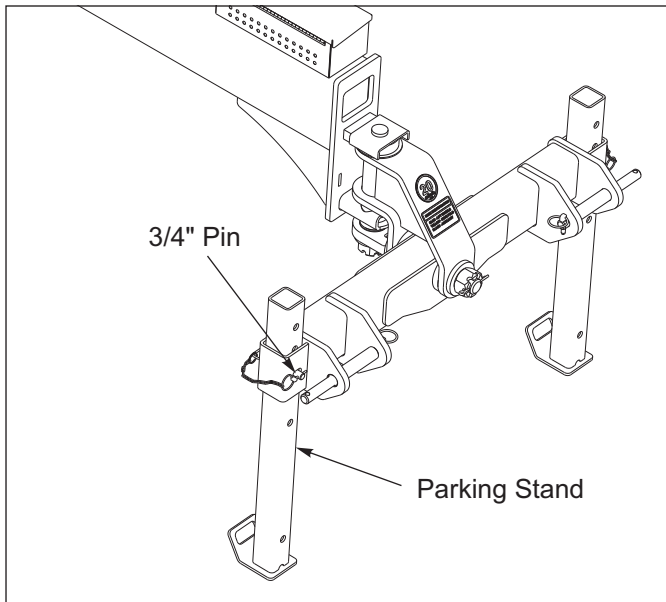

Figure 3-1: Parking Stand

3. Slowly lower 3-PT Hitch until weight is relieved from the tractor.
4. At the front of the Folding Seeder Hitch, disconnect the Elite Mini Tractor Harness and the Seeder Main Harness 6-Pin Plug connection. **See Figure 2-5.** This allows the Brillion Elite Mini Monitor to stay in the tractor if so desired.
5. Disconnect 7-Pin Warning Lamp Connector from tractor.
6. Disconnect the hydraulic hoses and place in the storage bracket above the hitch.
7. Carefully disconnect the 3-PT Hitch by unlocking Quick Hitch or removing pins from the lower lift links.

Hydraulic System

WARNING

Escaping hydraulic fluid can cause serious personal injury. Relieve system pressure before repairing, adjusting, or disconnecting. Wear proper hand and eye protection when searching for leaks. Use cardboard instead of hands. (See Figure 3-2.) Keep all components (cylinders, hoses, fittings, etc.) in good repair.

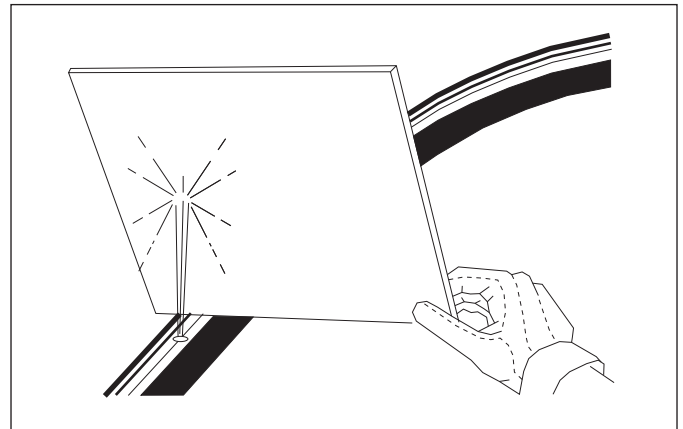

Figure 3-2: Hydraulic Leak Detection

The Folding Seeder Hydraulic System Hoses are color coded to aid in identifying the Hydraulic Circuits. An Identification Decal can be found on the Telescoping Drawbar Outer Tube. **See Figure 3-3.**

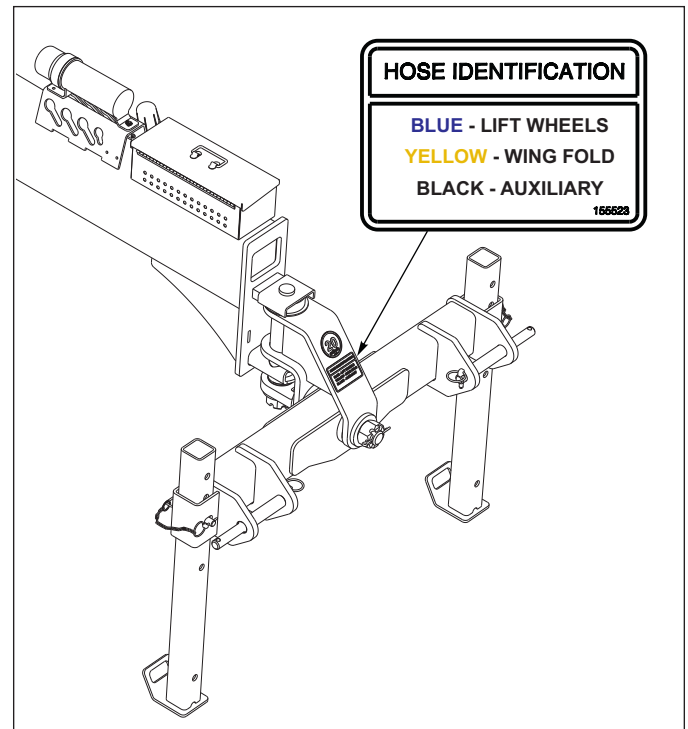

Figure 3-3: Hose Identification Decal

OPERATION

Hydraulic Lift System

The 4620-24 Folding Seeder is equipped with a Hydraulic Lift System to raise and lower the unit from transport to planting position.

1. If the hydraulic system is not filled with oil it should be purged of air before transporting and field operations. Carefully hitch the Seeder to the tractor and connect the hydraulic lift hoses.
2. Remove the Transport Locks and locate Locks to Storage Position. **See Figure 3-7.**
3. Check to make sure the tractor hydraulic reservoir is full of the manufacturer's recommended oil.
4. Slowly raise the machine until all lift cylinders are fully extended. Lower and raise the unit to verify that all cylinders are working throughout the stroke. Fully extend the lift cylinders and continue to hold the lever until all cylinder rod movement stops. Raise/Lower machine 5 times to purge air from the system.
5. Do not loosen any hoses or fittings. Recheck tractor reservoir to make sure it is within operating limits.
6. Re-install Transport Locks. **See Figure 3-8.**

Lift Circuit Hydraulic Fluid approximate requirement:

Machine Raised = **2.3 gallons**

Machine Lowered = **2.0 gallons**

Hydraulic Fold and Wing Lock System

! DANGER

The Folding Seeder should be folded/unfolded on a large level area large enough to accommodate the seeder when unfolded. Be sure other people and pets are a safe distance away. Tractor should be stopped and not moving, with the engine at a slow idle.

! DANGER

Keep all bystanders away from the machine when folding/unfolding or transporting.

The 4620-24 Folding Seeder is equipped with hydraulic cylinders to fold and unfold the seeder from transport to field position. A combination of the Fold, Lift and Wing Lock Hydraulics will be used to fold/unfold the seeder.

Before unfolding/folding the seeder, be sure the seeder is properly hitched to the tractor. **See "Attaching Folding Seeder to the Tractor" on page 3-2.**

UnFolding:

1. Fully raise the Seeder to relieve pressure off the Transport Locks. Remove Transport Locks and relocate to storage position. **See Figures 3-7 and 3-8.**
2. Activate Wing Fold Circuit. Continue to unfold the seeder until the 4 x 20 Hydraulic Fold Cylinders have fully extended.
3. Activate the Wing Lock Circuit (Auxiliary) retracting the 3-1/2 x 6 Slide Lock Cylinder and extending the two 2 x 3 Contour Lock Cylinders on each wing. Slide Lock Hooks should be engaged on each side of the Frame Tube and each wing will now move fore-aft and laterally. **See Figures 3-4 and 3-5.**
4. Lower Seeder with 3-PT Hitch and Seeder Hydraulic Lift to begin seeding.

Folding:

1. Raise seeder completely with Seeder Hydraulic Lift and tractor 3-PT Hitch.
2. Activate the Wing Lock Circuit (Auxiliary) extending the 3-1/2 x 6 Slide Lock Cylinder completely and retracting the two 2 x 3 cylinders on each wing. Seeder wings should now be locked to prevent fore-aft and lateral movement. **See Figures 3-4 and 3-6.**
3. Activate the Wing Fold Circuit. Fold the wings forward completely
4. Install Transport Locks over Lift Cylinder Rods and secure with bent pins and hair pin cotters. **See Figure 3-8.**

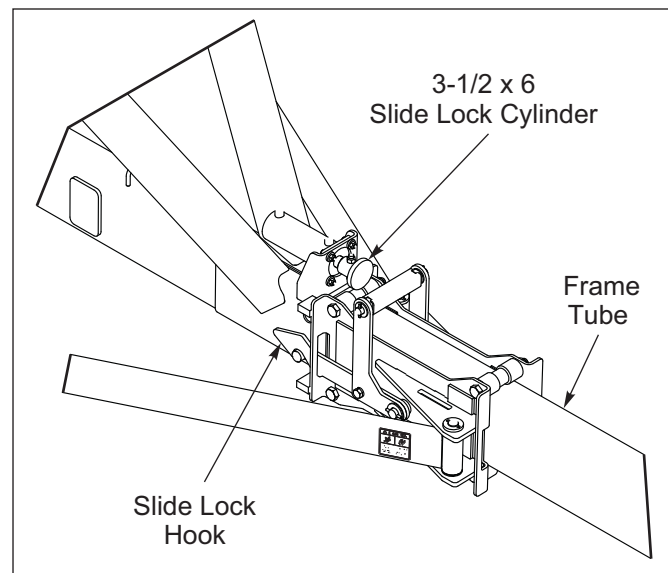

Figure 3-4: Wing Slide Lock

Fold Circuit and Wing Lock Circuit Hydraulic Fluid approximate requirement:

Machine Folded = **2.3 gallons**

Machine Unfolded = **2.7 gallons**

Wing Lock Engaged / Disengaged = **1.1 gallons**

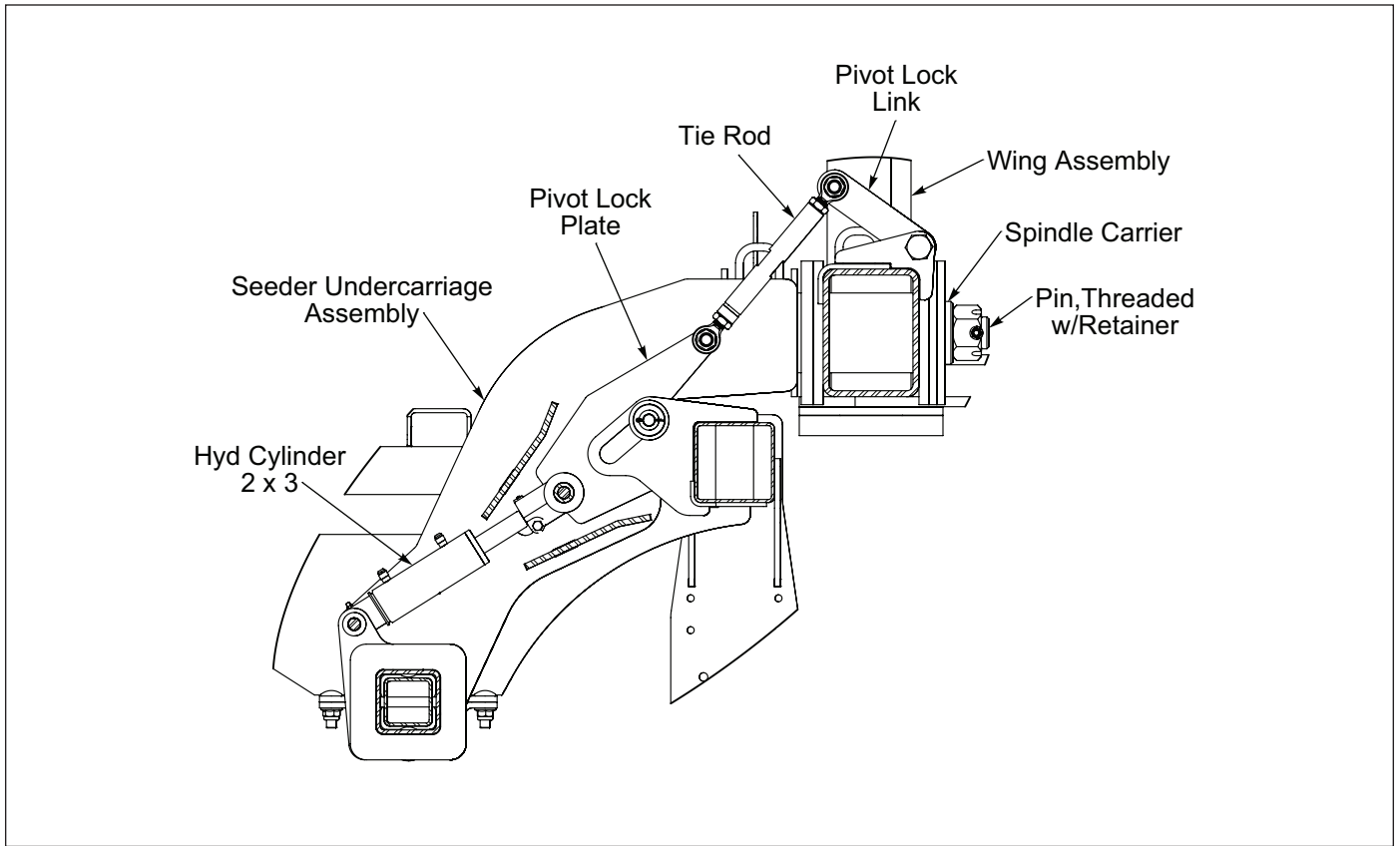

Figure 3-5: Pivot Lock Disengaged

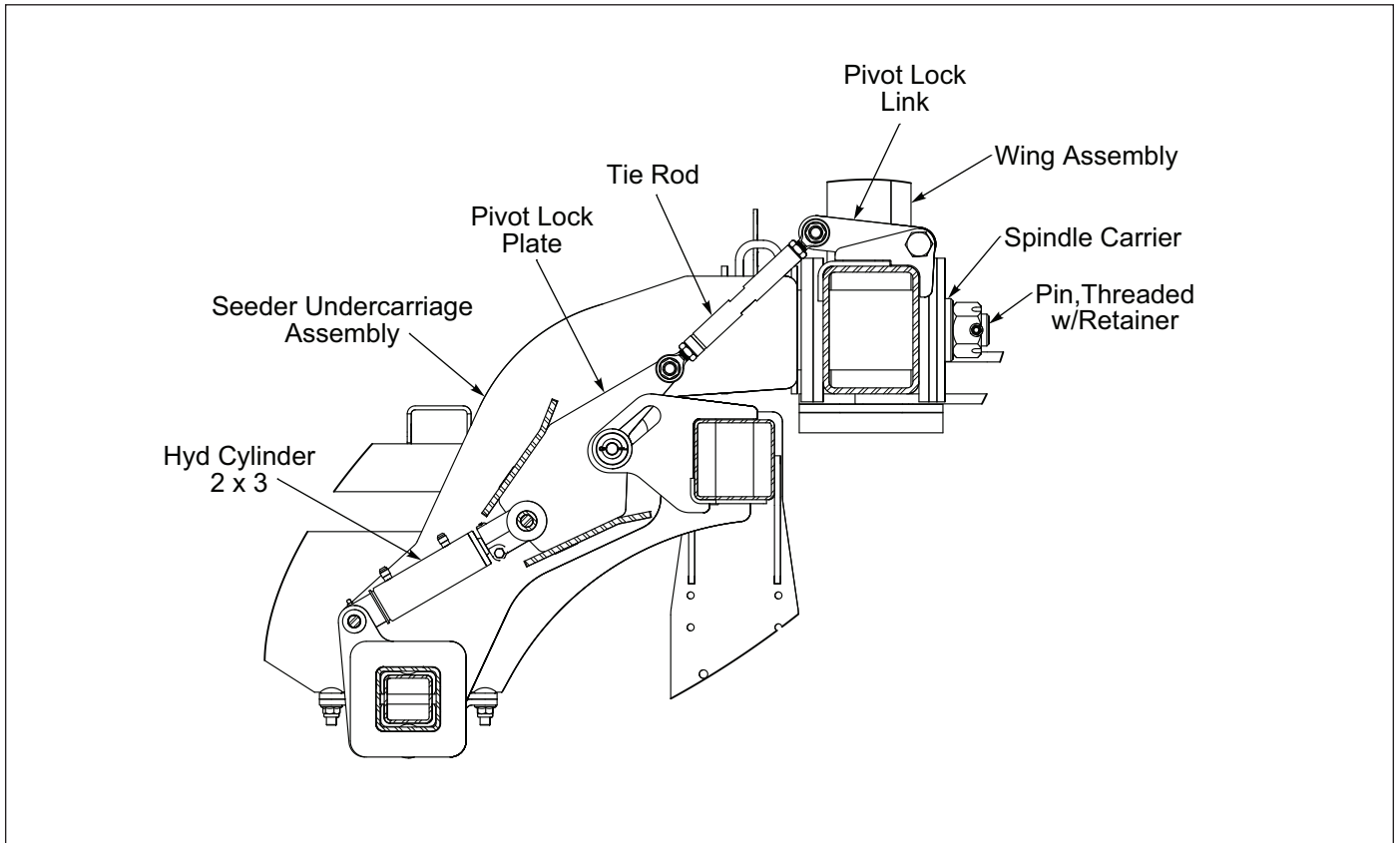

Figure 3-6: Pivot Lock Engaged

OPERATION

General Operation

1. The minimum horsepower requirement is typically 150 hp. This will vary widely due to speed, moisture, and types of soils. Local dealers can help in making recommendations for your areas.
2. 3 Point Hitch Lift Capacity requirement is 7500 pounds minimum.
3. Operating speed is typically 4.5-6 mph. Excessive speed can result in undesirable germination, seeder bouncing, or other unpredictable results. Reduce speed in rocky conditions to prevent wheel breakage.

Transport Locks

Transport Locks are provided to secure the 4620 Folding Seeder in raised and folded positions. Do not rely totally on hydraulics when working beneath raised equipment.

WARNING

Install transport locks before attempting to service, adjust, or transport raised equipment.

1. To install the Transport Locks, fully raise the machine. Remove the Transport Lock from the storage position and install it over the Hydraulic Cylinder Rod. See **Figures 3-7 and 3-8.**

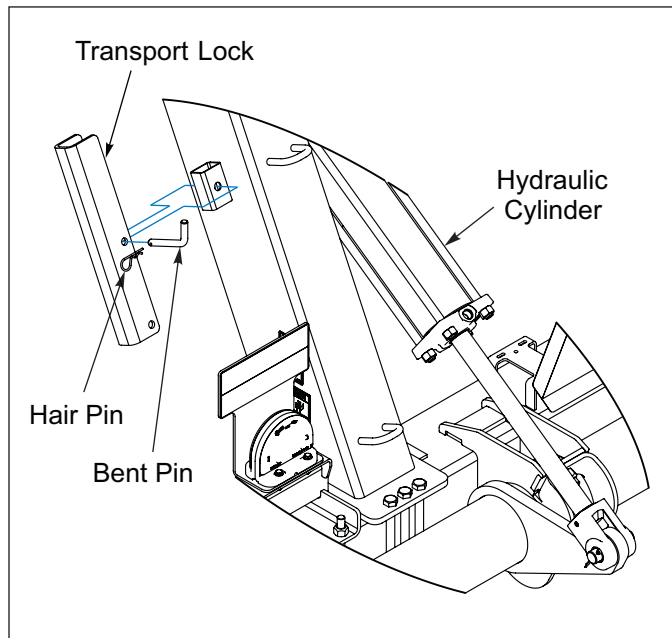

Figure 3-7: Transport Lock Storage Location

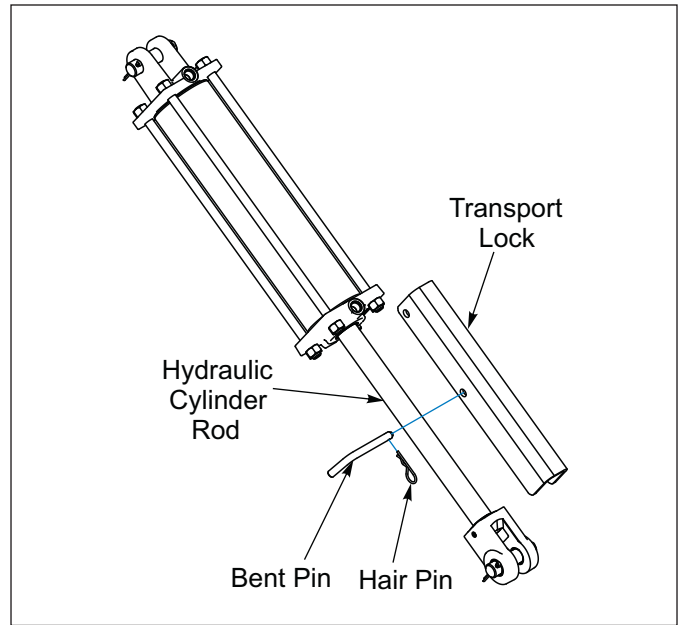

Figure 3-8: Transport Lock Installed

Seed Rate Adjustment

WARNING

- To prevent damage to the seed meters, do not apply excessive force to the adjusting nuts. Failure to do so may result in the seed being pinched between the cut-off and washer inside the seed cup.
- Do not close the meters more than 1/8" when there is seed in the meters without rotating the seed shaft. This prevents damage to the rotating washers and retainer rings in the seed meters.
- Do not attempt to open meters more than 1". (Feed rolls could become disengaged from washer in the seed cup.)

NOTE

To avoid seed meter damage, if there is seed in the meters, decrease rate in small increments. Decrease rate no more than one nut revolution and rotate seed shaft to purge seed from meters. Continue adjustment as needed.

NOTE

Before filling with seed be sure seed shaft turns freely and seed meters are free of any foreign matter.

Wrenches for adjustment and the Calibration Crank Assembly are stored in the toolbox. See Figure 3-9.

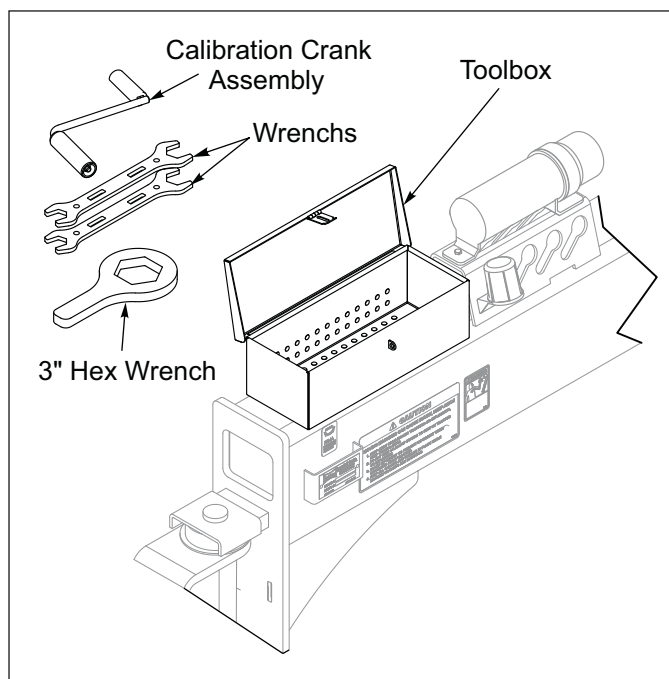

Figure 3-9: Adjustment Wrenches

IMPORTANT

The clutch must be disengaged (power off) when seed shafts are turned manually for calibration.

The seed rate chart is located inside the seed box cover and in this manual. See Figure 3-11. It should be used as a general guide only. Because of seed variation, a more accurate rate can be determined by turning the 3/4" Hex Nut on the transmission to calibrate the seeder. See "Calibration for Unlisted Seeds" on page 3-9.

On the right side, the Seed Rate for the Seed Meters can be set by adjusting the Seed Rate Adjusting Nut and Adjusting Screw. See Figure 3-10.

IMPORTANT

DO NOT Loosen or Adjust the Hex Nuts with Set Screws.

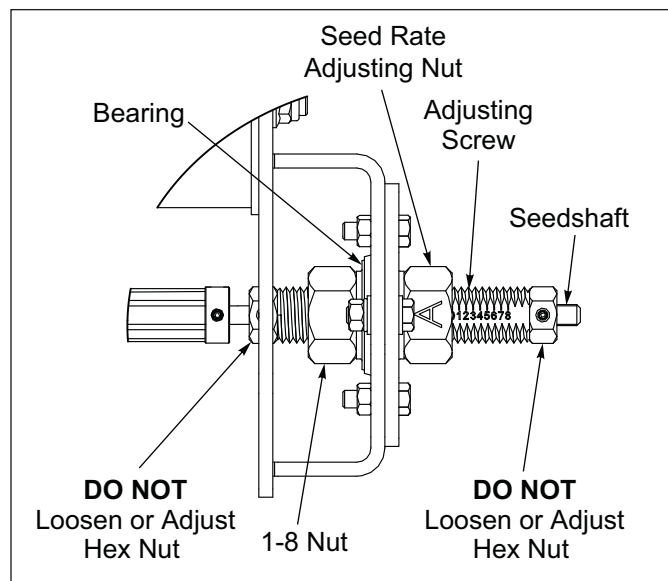

Figure 3-10: Seed Rate Adjustment

1. To increase the rate of seeding, loosen the 1-8 Nut on inside of the Bearing and turn the Seed Rate Adjusting Nut to the desired setting, then tighten the 1-8 Nut using supplied wrenches.
2. To decrease the rate of seeding, loosen the Seed Rate Adjusting Nut and set it to the new desired position, then tighten the 1-8 Nut using supplied wrenches.

Seed Meters discharge to the front of the machine to aid the operator in determining proper operation. In addition, reflective amber decals are placed on the seed shaft to indicate rotation.

Seed Rate Chart

PLANTING RATES FOR 4620, 15 BU MICROMETER, GROUND DRIVE IN POUNDS PER ACRE

RATES ARE INTENDED AS A GUIDE ONLY. VARIATIONS IN SIZE AND CLEANLINESS WILL AFFECT RATES. CHECK ACREAGE AND POUNDS OF SEED USED FOR BEST RESULTS.

INDICATOR SETTINGS	1A	2A	3A	4A	5A	6A	7A	8A
ALFALFA (UNCOATED)	3	7	13	19	23	29	34	39
BAHIA	1	6	10	14	19	23	27	30
BERMUDA (HULLED)	3	7	13	20	24	30	34	40
BIRDSFOOT TREFOIL (BROADLEAF)	3	9	14	20	30	36	44	51
BLUE GRASS (KENTUCKY)	1	3	4	7	9	11	13	14
BLUE GRASS (PARK KENTUCKY)	1	4	7	11	14	19	21	24
BLUE GRASS (SHERMAN BIG)	0	1	4	6	7	9	10	11
CANOLA	1*	7*	11	17	21	26	30	36
CENTIPEDE	3	7	9	13	17	20	23	26
CLOVER (ALSIKE, LADINO, SWEET, RED)	3	9	13	19	24	30	34	40
CLOVER (ALYCE, CALIFORNIA BUR, CRIMSON, HUBAM)	3	7	11	17	24	28	34	43
CRESTED WHEAT	0	1	3	4	6	7	9	10
CROWN VETCH	3	10	16	21	29	34	41	49
FLAX	3	7	11	14	19	23	27	30
HARDING GRASS	1	6	9	13	16	20	23	26
KLEIN GRASS	3	7	14	19	26	33	40	44
LESPEDEZA (KOREAN UNHULLED)	1	6	10	14	20	24	30	34
LESPEDEZA (KOREAN HULLED)	3	7	13	19	23	30	36	40
LESPEDEZA (SERICEA UNHULLED)	1	4	7	11	16	19	21	24
LESPEDEZA (SERICEA HULLED)	3	9	14	21	27	34	41	46
LOVE GRASS (WEEPING)	1	9	14	19	24	31	37	44
LOVE GRASS (SAND)	3	7	11	16	21	27	33	39
MILLET	3	9	14	20	26	31	37	44
RED TOP	1	3	6	7	9	10	11	13
REED CANARY GRASS	1	3	6	9	10	13	14	19
SWITCH GRASS (CLEANED AND HULLED)	0	3	6	7	10	13	16	19
TEFF - TIFFANY COATED	4	9	14	20	27	31	38	44
TILLAGE RADISH	3*	9	13	19	24	30	35	41
TIMOTHY	3	6	10	16	20	26	31	36

* WILL CRACK SOME SEEDS AT THESE SETTINGS
 NOT RECOMMENDED: LENTILS, SORGHUM, SUDAN GRASS

Figure 3-11: 4620-24 Seed Rate Chart

Calibration for Unlisted Seeds

IMPORTANT

The clutch must be disengaged (power off) when seed shafts are turned manually for calibration.

Landoll assumes no liability pertaining to seeding rates achieved with this seeder. Rates listed are general in nature and should be used as starting points only. Seed varieties and blends listed represent those calibrated through in-house test meters.

Variations in actual rates may be realized due to differences in seed lots. For accurate rates with seeds being used, follow the calibration instructions listed on the seed chart inside the box cover or refer to the Operator's Manual. *The information listed in the above seed charts is subject to change without notice.*

Calibrate Unlisted Seeds as follows:

1. Seed Shaft turns 163 Revolutions per Acre Seeded.
2. Raise machine and lock in Transport Position.
3. Place a canvas or tarp under machine to catch any seed.
4. Disengage Clutch. Turn 3/4 Hex on Transmission Shaft 163 revolutions Counter-Clockwise (CCW) with provided Crank, 41 turns may be used if results are adjusted as stated in Step 5. **See Figure 3-12.**
5. Weigh seed for approximate planting rate in lbs/acre multiply weight by 4 if only 41 turns were used.

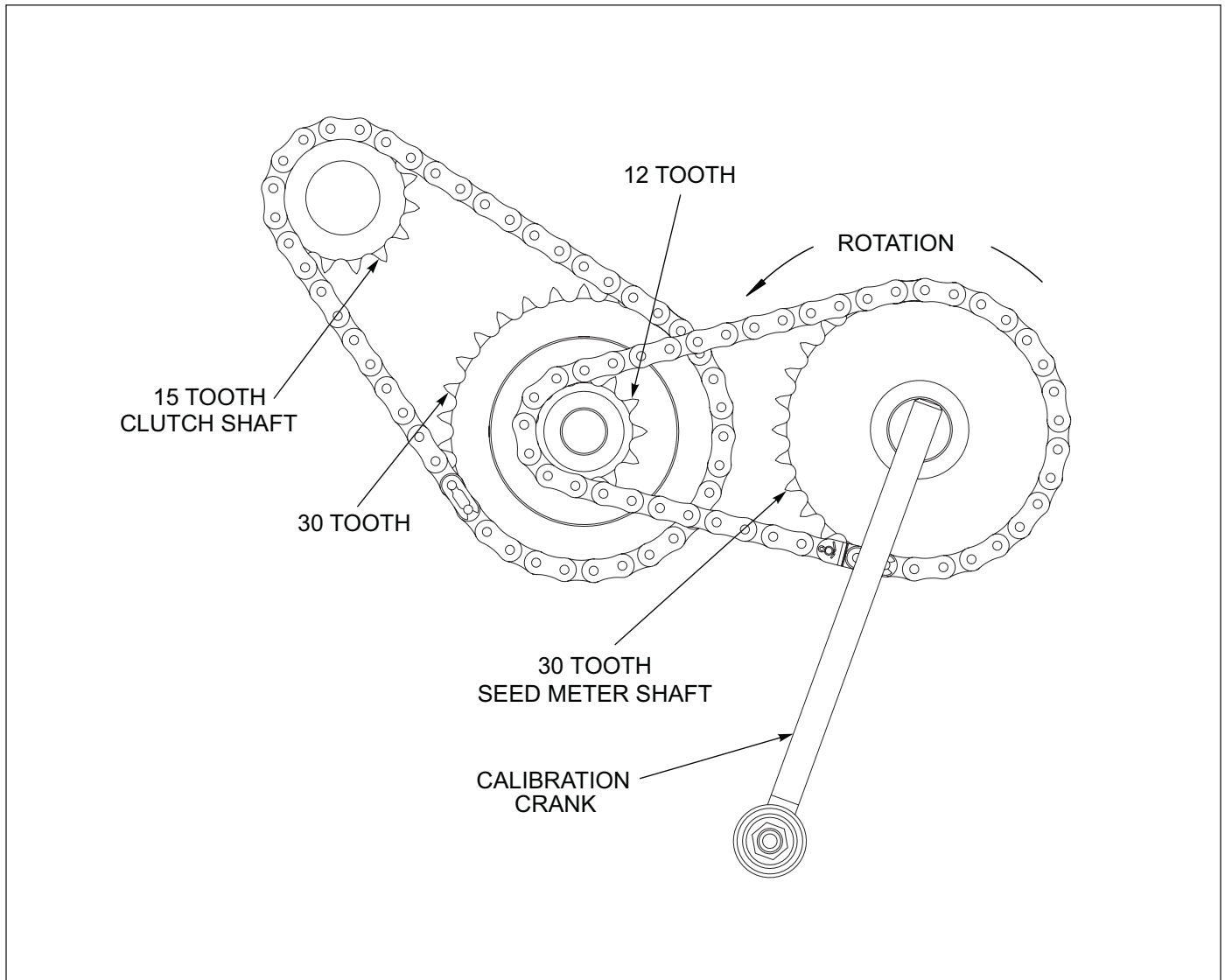

Figure 3-12: Calibration

OPERATION

Clutch Operation

The Clutch is controlled by the Brillion Elite Mini Monitor.

Clutch characteristics are as follows:

1. The Clutch is **engaged** when power (12 volts) is applied.
2. The Seeder has provisions to mechanically lock the Clutch to drive the Seed Metering System, by aligning the hole in the Clutch Shaft with the slot in the Clutch Hub and securing with a 1/4 x 1-3/4 Bolt, Flat Washers and Locknut. **See Figure 3-13.**
3. The Clutch must be disengaged (power off) when Seed Shafts are turned manually for calibration.
4. Check clutch operation: Clutch will engage when power is applied. (Clutch will make a clicking sound). Set seeder on the ground and drive a short distance while toggling the Seeder Clutches "ON" and "OFF" on the Brillion Elite Mini Monitor. The Seed Shaft will stop rotating when switch is toggled to "OFF" position.

IMPORTANT

At no time use high pressure water or air to clean the clutch as damage could occur.

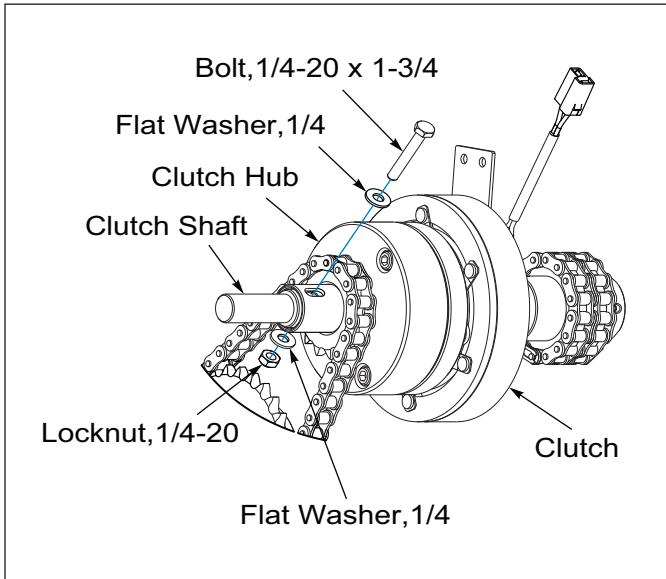

Figure 3-13: Clutch Lock Bolt

Brillion Elite Mini Monitor

Brillion Elite Mini Monitor provides information to the operator and acts as an interface for clutch control. The display shows seed shaft rotation, low bin levels, acres seeded, and clutch engagement. The touch screen allows the operator to engage all or individual clutches.

See "Brillion Elite Mini Monitor" Chapter for more information and a detailed guide to the use of your monitor.

IMPORTANT

The Brillion Elite Mini Monitor System by Loup utilizes a MUX communication line. Sensors must be learned into the Monitor. Location of each pre-learned Smart Shaft Sensor or Bin Level Sensor is important for proper Monitor display. Each Sensor utilizes 3 wires (+, -, MuxBus) to connect to the system. The Harnesses do not require a specific Sensor connection points. Each Sensor is identified in the Monitor by its own signal.



WARNING

High Power Magnet in use. "High Power Magnet" on page 1-2

- Bin Level Sensors are installed on adjustable brackets in the outer end of each seed box. When the sensor is submerged in seed, no alarm will sound. As the seed level falls below the sensor eye, an alarm will be indicated on the Brillion Elite Mini Monitor. Raise or lower the Bin Level Sensor Bracket inside the Seed Box to the desired seed level.
- On the Rear RH side of each Seeder Section is a Smart Shaft Sensor that is installed on a Sensor Mount that is attached to the mounting hardware of two seed cups. The Smart Shaft Sensor is activated by a High Powered Magnet in a Spacer that is kept in place from rotating on the Seed Shaft with Set Screws. As the seed shaft rotates the Smart Shaft Sensor detects the magnet. When no signal is detected for pre-defined seconds, an alarm will be indicated on the Brillion Elite Mini Monitor. **Note: If shaft sensor stall alarm occurs, be aware that the affected seeder has not been planting for pre-defined seconds.**
- Brillion Elite Mini Monitor provides users the ability to toggle the seeder clutches on or off.
- Brillion Elite Mini Monitor will monitor field and total acres.
- Brillion Elite Mini Monitor is operated on a 12-Volt DC negative ground system. The monitor should be connected using the existing convenience plug connection.

- The Elite Mini Tractor Harness attaches to the Brillion Elite Mini Monitor and connects the Seeder Main Harness. See Figure 2-5. The 6-Pin Connection may be plugged/unplugged at the front of the Folding Seeder Hitch when hooking/unhooking the Folding Seeder. This allows the monitor to stay in the tractor if so desired.
- A 4-Pin radar connection is provided as an optional connection for the speed sensor. The speed signal may be determined by either the tractor radar or the speed sensor located on the Seeder.
- For service or setup questions contact Loup Electronics Inc. See "Service And Technical Support" on page 4-8.

Console w/Clutch Control

(Used on models before the Brillion Elite Mini Monitor)

Basic Operation:

During normal operation the monitor LED for each shaft will not be illuminated. The shaft sensor will be activated by a magnet attached to the shaft being monitored. The shaft sensors are standard Loup shaft sensors, set to 20 second delay timing. When no signal is detected for 20 seconds by the sensor, the corresponding LED in the console will illuminate and the audible alarm will sound indicating a fault. The alarm will become silent after 30 seconds and will not sound again until all shafts return to a fully functional condition. The LED for other shafts will indicate a second fault but the alarm will not sound unless all shafts are functional after the INITIAL alarm.

NOTE

If shaft sensor stall alarm occurs, be aware that the affected seed box has not been planting for 20 seconds.

The Clutch Master toggle switch allows you to go from SEED to No SEED operations or you can control individual clutches by toggling the appropriate switch. See Figure 3-14.

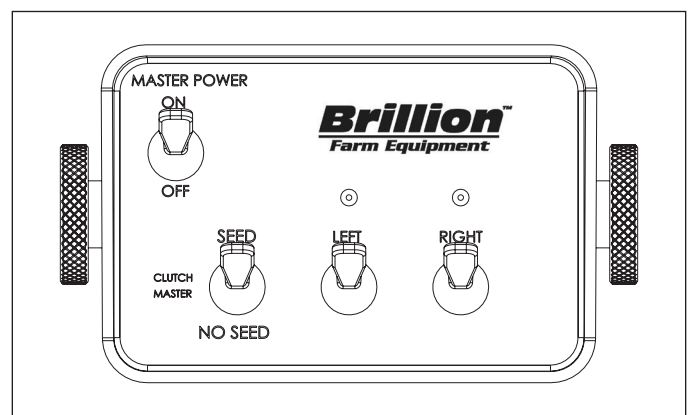

Figure 3-14: Console w/Clutch Control

OPERATION

Coil Tine Harrow

The Seeder has a Standard Coil Tine Harrow to remove tire tracks before the rollers compact the soil. The coils are individually mounted for flexibility and backup protection. The Tines depth should be adjusted so the tips are approximately 2" into the soil.

NOTE

The tines will hang straight down when the implement is raised.

1. The Coil Tine may be adjusted up or down as needed.
2. Adjust the Coil Tine Harrow depth by removing the 3/8-16 x 1-1/4 Bolts and Locknuts and moving the Harrow Assembly up or down to achieve the desired depth. (The holes are 1-1/4 inches apart)
Re-Insert 3/8-16 x 1-1/4 Bolts and secure with Locknuts. Both sides should be set at the same depth.
See Figure 3-15.

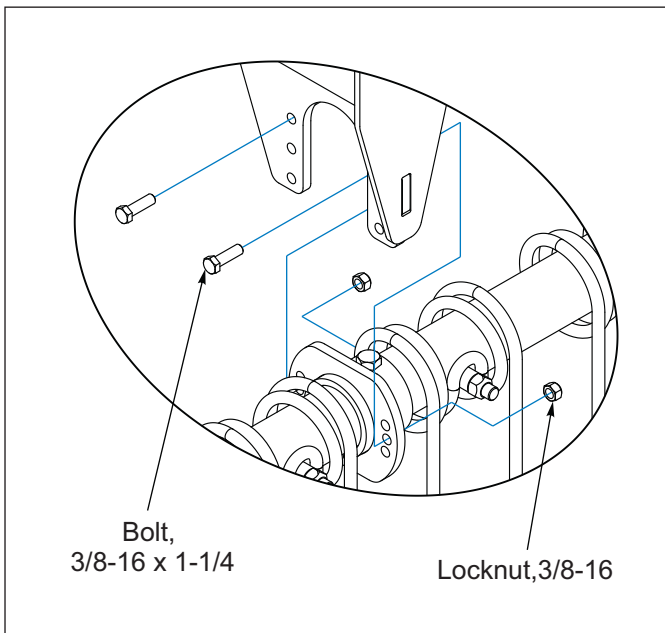

Figure 3-15: Coil Tine Harrow Adjustment

Transporting the Folding Seeder

1. Check and follow all federal, state, and local requirements before transporting the Folding Seeder.
2. The Folding Seeder should be transported only by a tractor required for field operation. The implement weight should not exceed more than 1.5 times the tractor weight. Unless noted on the implement, maximum transport speed is 20 mph for the implement and is designated on the Speed Identification Symbol (SIS) located on the front of the implement.

CAUTION

Excessive speed may result in loss of control of the tractor and implement, reduced braking, or failure of the implement tires or structure. Do not exceed the implement maximum specified ground speed regardless of the capability of the maximum tractor speed.

3. Always fully fold Seeder Wings prior to transport.
4. Slow down when driving on rough roads. Reduce speed when turning, or on curves and slopes to avoid tipping. Equipment altered other than the place of manufacture may reduce the maximum transport speed. Additional weight, added tanks, markers, harrow attachments, etc. may reduce the implements carrying capabilities.
5. Before transporting Folding Seeder:
 - a. Know the height and width of the implement being towed. Markers, tanks, attachments, etc. can increase the height and width of the implement.

DANGER

Stay away from power lines when transporting, extending or folding implement. Electrocutation can occur without direct contact.

- b. Check to see that the tractor hitch capacity is rated to carry the weight of the Folding Seeder Hitch. **Refer to Tractor Operator's Manual.**
- c. Use provided pins that properly fits the Lift Arms or Quick Hitch and Implement Hitch.
- d. Clean all Hydraulic Couplings and attach to tractor remotes.
- e. Connect Brillion Elite Mini Monitor System to tractor.
- f. Connect the Safety Warning Lights 7-Pin Plug into tractor 7-Pin outlet, routing cord by avoiding pinch points.

- g. Fold the Folding Seeder. Fully raise the Seeder Rockshaft and 3-PT Hitch.
- h. Make sure all transport locks and pins are installed. Do not depend solely on the implement hydraulics for transport. **See Figure 3-8.**

WARNING

Failure to use transport lock pins during transport may result in permanent equipment damage, serious injury, or death.

- i. Check all tires for proper inflation, and that lug nuts are properly torqued. **See "Tires" on page 5-3.**
- j. Verify that all warnings lights, SMV sign, reflectors, and safety decals are clearly visible and functioning properly.
- k. Raise the implement parking stands. **See Figure 3-1.**
- l. Transport during daylight hours whenever possible. Always use flashing warning lights, except where such use is prohibited by law. Make sure lights, reflectors and SMV emblem are clearly visible and operating. Remove any obstructions such as dirt, mud, stalks or residue that restricts view before transporting.



Figure 3-16: SMV Sign and SIS Decal

Brillion Elite Mini Monitor

Overview

The Brillion Elite Mini Monitor is a full featured display designed to provide accurate information to the operator for Ground Speed and Acres Planted, Seeder Unit Clutch Control, Seed Shaft Rotation, and Bin Level. This Chapter will familiarize you with operation and technical information. All aspects and features are detailed but may not be applicable to your system configuration.

- **Ground Speed** (Implement mounted Ground Speed Sensor, Radar, GPS Speed or Simulated Speed)

- **Field Acres and Total Acres**
- **Clutch Control**
- **(Up to 6) Six Seed Shaft Rotation Sensors**
- **(Up to 6) Six Hopper Level Sensors**
- **Clutch Master On/Off Switch**

WARNING

High Power Magnet in use. See "High Power Magnet" on 1-2.

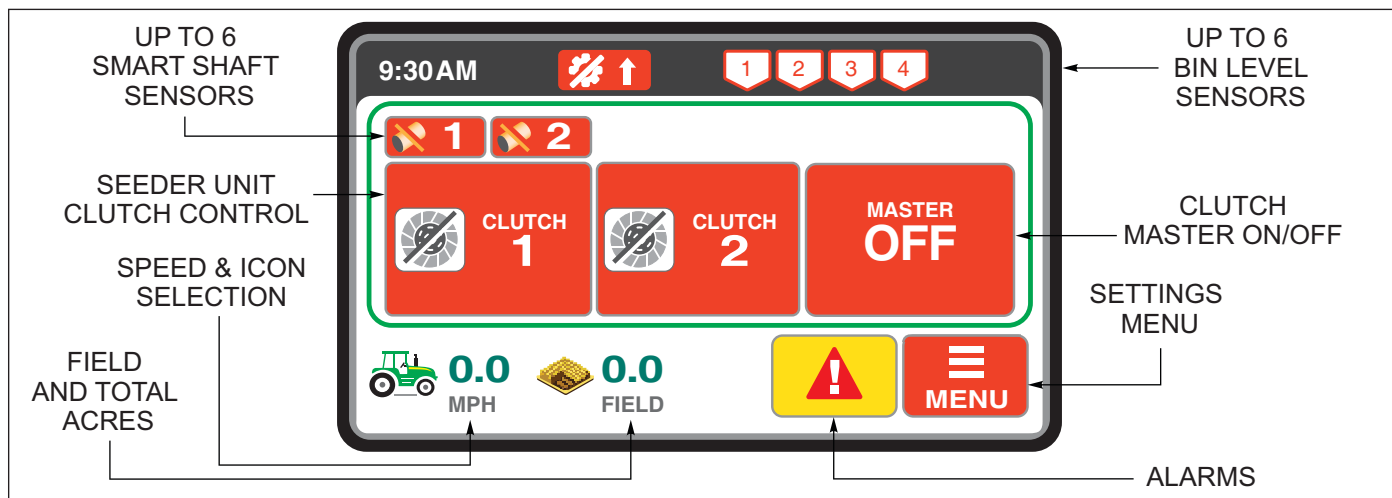

Figure 4-1: Main Screen Display (4620)

Main Screen Layout

Speed & Icon Selection

Implement Speed will display in lower left corner of the display. To change the tractor color, tap the tractor icon in the lower left corner to prompt a menu. From the pop-up, select the color.



Field & Total Acres

NOTE

Acres seeded accumulate only for the seeder sections that have the clutch engaged "ON/Green".



Touch **Field or Total Acres** to toggle between them.

Clear Field Acres: Touch and hold field numbers for 3 seconds. Field Acres Reset Screen will pop-up. Select "Yes Confirm".

Clear Total Acres: Touch and hold total numbers for 3 seconds. Total Acres Reset Screen will pop-up, select "Reset Total Acres". Warning Screen will pop-up, select

"Yes Confirm". Password Screen will pop-up. Enter 4-digit password.

Alarms

When an alarm is sounded a popup message will display the active alarm. You may choose to either clear that single alarm or clear all alarms to clear the popup and silence the display.



A flashing yellow button will display next to the Menu Button to signify alarm(s) that are currently active. Select the yellow alarm button to go to the Alarms Screen which will outline all current alarms active on the console. The flashing indicator will not disappear until all alarms have been resolved.

ACTIVE ALARMS ← BACK

<p>GENERAL ALARMS: SHAFT 1,2 LOW RPM BIN 1,2,3,4 EMPT</p>	<p>COMM ERRORS: NO COMM ERRORS</p>
--	---



Figure 4-2: Settings Menu Display (4620)

Settings Menu - Speed Settings



Located by selecting “Menu” and “Speed Settings”, these settings control the type of speed input being used as well as calibrating the speed displayed on the main screen.

Speed Source

Change “Speed Source” by pressing the **Current “Source” Button**. Choose between Shaft Sensor, Radar, GPS Receiver, and Simulated Speed. Screen displays the new Source and options.

CURRENT “SOURCE” BUTTON

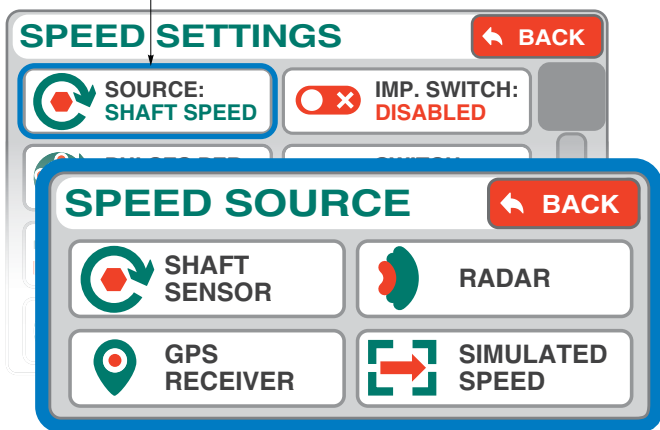

Source: Shaft Sensor Speed

Uses the Smart Shaft Sensor located on the Center Seed Unit Clutch Shaft to obtain ground speed.



Source: Radar Speed

Uses a tractor equipped with radar to obtain your source of ground speed.



Source: GPS Receiver Speed

Uses a GPS receiver for your source of ground speed.



Source: Simulated Speed

Allows you to enter a static speed into the monitor without any other speed source. For use in more unique conditions such as a GPS/Radar failure, or other troubleshooting.



Speed Source Displays

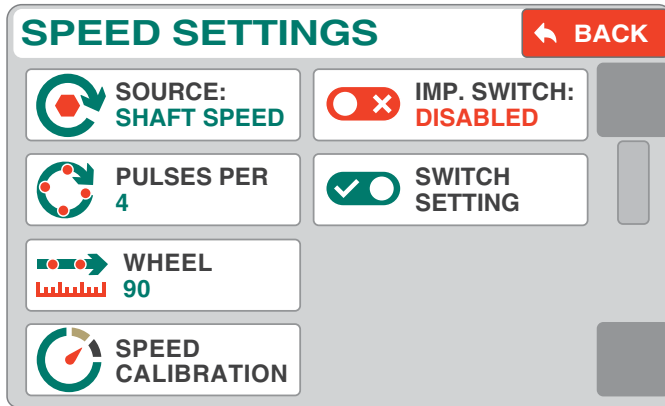

Figure 4-3: Source: Shaft Sensor Speed Display

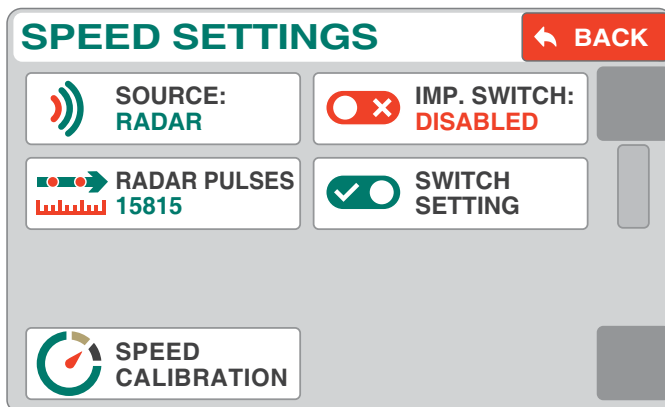

Figure 4-4: Source: Radar Speed Display

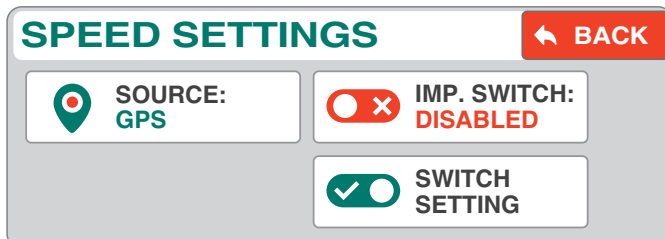

Figure 4-5: Source: GPS Receiver Display

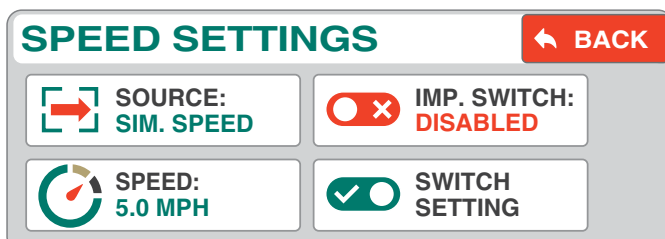

Figure 4-6: Source: Simulated Speed Display

Speed Source Icon Features

Pulses Per Revolution

Pulses Per Revolution are the number of magnets the implement mounted speed sensor sees in one revolution of the shaft being monitored. For Brillion Seeders this number is 4.



To change, enter a new number into the keypad and select "Exit & Save".

Wheel Pulses Per 400FT

This is the ground speed calibration number for a implement mounted speed sensor. See "Speed Calibration" for calibration instructions.



The Default number is 90. **MUST BE CHANGED** to 180. To change, enter a new number into the keypad and select "Exit & Save". Increasing this number will cause the monitor to show a slower MPH, decreasing it causes the MPH to increase.

Radar Pulses Per 400FT

This is the ground speed calibration number for a radar speed sensor. See "Speed Calibration" for calibration instructions.



Speed (Simulated Speed)

Enter the static speed of your choice. The monitor will continually display this speed at all times until otherwise specified.



BRILLION ELITE MINI MONITOR

Speed Calibration

All new systems require a ground speed calibration to ensure accurate area totals and accurate ground speed readings. To complete the calibration, measure a course 400 long preferably on level ground with a start and finish point. The seeder must be in the down position throughout this procedure.

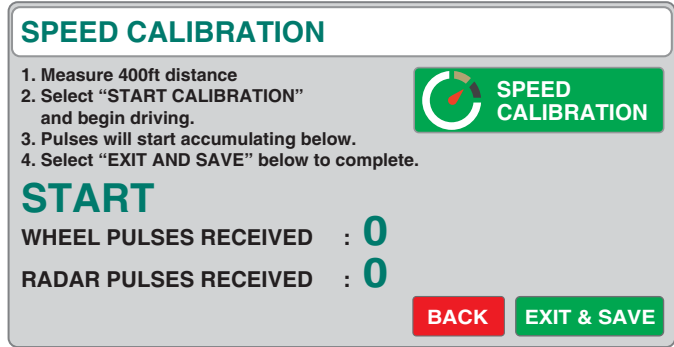

NOTE

During the calibration the monitor is looking for the number of pulses produced from the seeder mounted sensor or in the case of radar, the number of radar pulses.

1. Select the “Start Calibration” button to begin.
2. As you drive the 400ft. distance, pulses for both Wheel Pulses and/or Radar Pulses will begin accumulating on-screen.
3. When you’ve reached the end of the 400ft. distance, select “EXIT & SAVE” to complete the calibration procedure. Depending on which “Speed Source” is selected, the monitor will store this value into either the “Wheel Pulses Per 400” or “Radar Pulses Per 400” area.



Implement Switch

The implement switch is used to tell the monitor if a Lift Sensor is being used to determine when the machine is raised or lowered. The Lift Sensor is used when shaft rotation cannot be used or a variable rate drive such as common on air seeders, is being used. The “Imp. Switch” button toggles between “Disabled” or “Enabled”. **Set to “Disabled” for Brillion 4620-24 Folding Seeder.**



When the Monitor learns a “Lift Switch Sensor” toggle the “Implement Switch” button to “Enabled”.



Implement Switch Setup

Implement Switch Setup tells the monitor if the Implement Switch Lift Sensor is associated with the Implement Lift being raised or lowered.

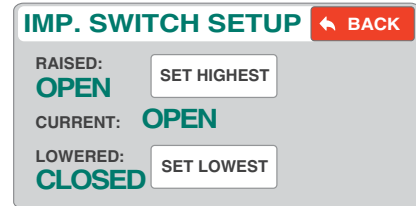

The Implement Switch Setup toggles between “Open” or “Closed”. Select icon “Set Highest” or “Set Lowest” to “Open” the Implement Switch, the other will automatically “Close”.

Settings Menu - Clutch Setting



The 4620-24 Folding Seeder has a Clutch on each Seeder Unit that will be controlled by the Brillion Elite Mini Monitor. Each Clutch must be set.



1. Set “Total Clutches” to 2 by pressing icon “-” or “+”
2. Set each “Clutch Details” as follows: to toggle between each Clutch Detail press icon **NEXT** or **PREV.**
 - Clutch engage at: 12 Volts (Toggles between 0 and 12 Volts)
 - Section Width: 12.0 Feet
3. Select “BACK” to get to the Setting Menu.

Settings Menu - Install Setup



Select “Install Setup” icon to Learn New System, Add A Sensor, or Remove A Sensor to your machine.

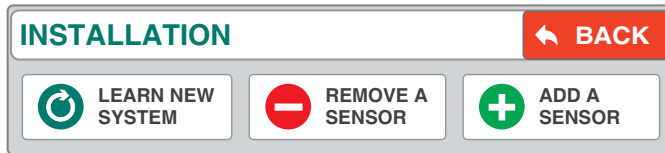

Learn New System

Select “Learn New System” if your monitor did not come pre-programmed or you wish to relearn all sensors.



1. Start by unplugging all sensors on the implement and then selecting “Learn New System”. A popup will warn you that all current sensors will be overwritten. Select “Yes, Learn New System”.
2. Refer to Brillion Elite Mini Monitor Single Seed Box Schematic for Sensor Locations. See Figure 2-5.

The monitor will prompt “Plug In Sensor” (all sensors have a 3-Pin Connector with white, black and green wires) in the following order. The sensor being prompted will automatically be learned upon connecting the 3-Pin Connector.

- “Plug In Sensor - Speed” Ground Speed Smart Shaft Sensor installed only on Center Seeder Unit Clutch Shaft.
- “Plug In Sensor - Clutch Box” Clutch Smart Relay installed in the Elite Mini Tractor Harness
- “Plug In Sensor - Shaft 1-6” Smart Shaft Sensors up to six sensors installed on the Seeder Units Seed Shaft.
- “Plug In Sensor - Bin 1-6” Bin Level Sensors up to six sensors installed inside Seeder Unit Front Seed Box.

3. It is likely your system will not be configured for the maximum possible sensors or even certain types of sensors the Loup Elite is capable of.

Use the “Skip this Sensor” button to advance ahead one sensor at a time.



Use the “Skip this Type of Sensor” to advance to the next category of sensors.



4. When you’ve reached the end of the list of sensors, you will be prompted with “Manual Learn Complete”. Push “OK” to finish.

Remove A Sensor

Select this option to remove a sensor from your existing system.



1. Select the type of sensor you wish to remove.

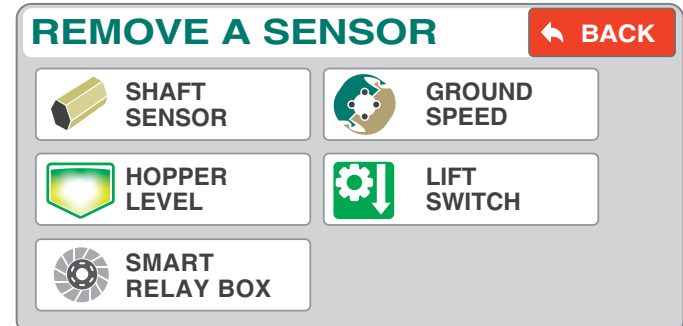

2. Use the **Left and Right Arrows** to navigate to the sensor number you wish to remove.
3. Select the “Remove A Sensor” button to complete the removal.

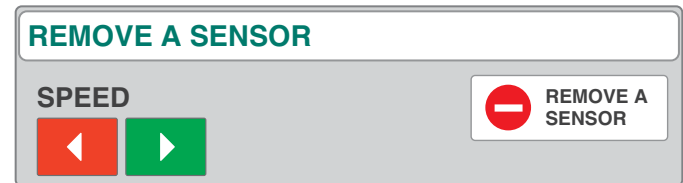

Add A Sensor

Select this option to add a new sensor to your existing system.



1. Select the type of sensor you wish to add.

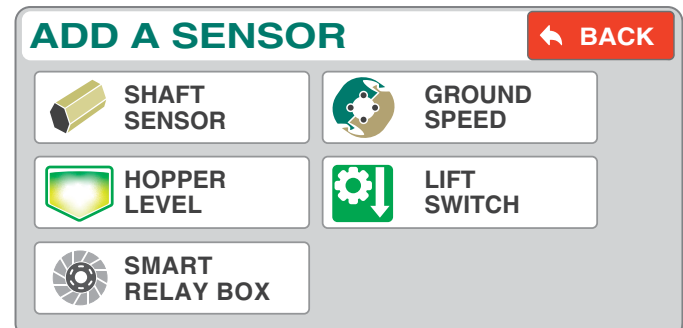

2. Use the Left and Right arrow buttons to navigate to the sensor number you wish to add.
3. Select the “Add A Sensor” button to complete the sensor addition.

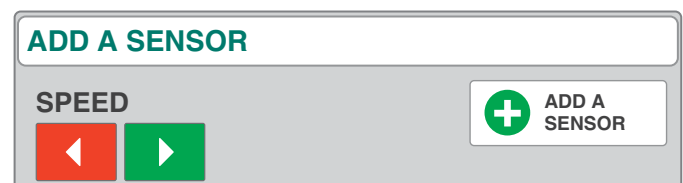

Settings Menu - Shaft Settings



Seed Shaft Settings

4620-24 Folding Seeder can have up to six Smart Shaft Sensors that indicate shaft rotation. Each Smart Shaft Sensor must be set.

- Pulse per Rev: 1
- Alarm Time: 20 Sec.

Toggle between each “Shaft” by pressing icon “<” or “>”. Select “Back” to get to the Settings Menu.

The 20 second Alarm Time is the estimated time it takes to turn around after each pass in the field without sounding the Alarm. This can be adjusted by the operator if more or less time is required before the Alarm Sounds.

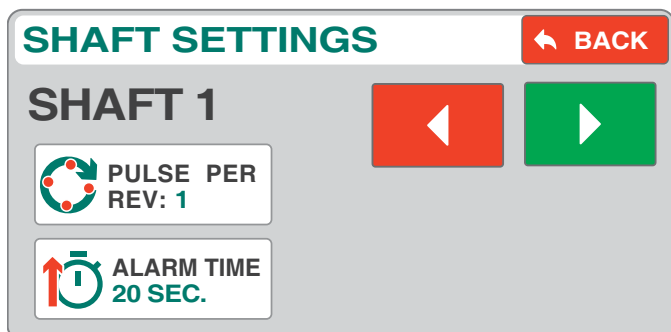

Ground Speed

4620-24 Folding Seeder has one Smart Shaft Sensor located on the Left Seeder Unit Clutch Shaft that indicates ground speed. The Smart Shaft Sensor/Ground Speed must be set.

- Pulse per Rev: 4
- Alarm Time: 20 Sec.

Toggle between each “Shaft” by pressing icon “<” or “>”. Select “Back” to get to the Settings Menu.

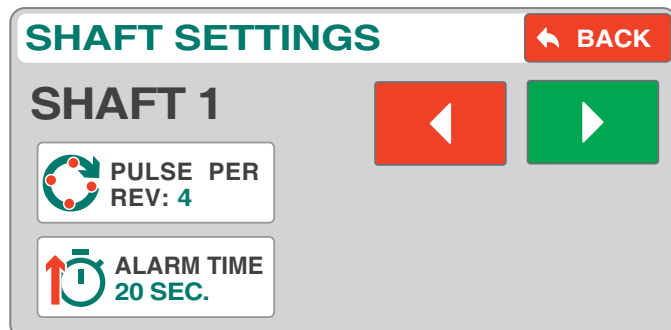

Settings Menu - Diagnostics



The Diagnostics screen can help in identifying issues with sensors, harnessing or other items. Status reports for Battery Voltage, Sensors Learned, MUX Communication speed and GPS Communication speed are displayed. Contact Loup Electronics if you need technical support.

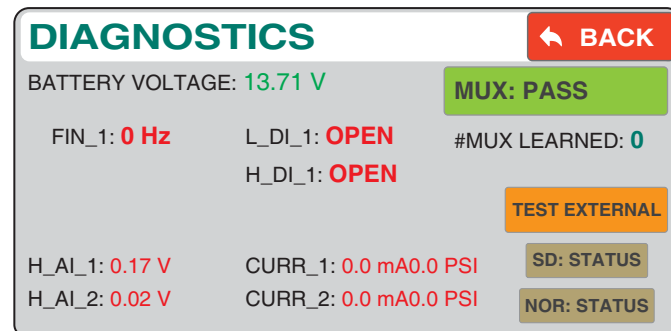

Settings Menu - GPS Settings



“GPS Settings” defines any Baudrate, Speed Corrections or the current GPS Status.

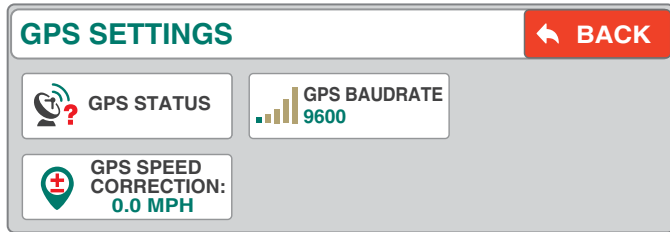

GPS Status

The GPS Status screen gives a diagnostics report of the current Latitude, Longitude, Number of Satellites connected and the Type/Quality of the GPS Fix. If the GPS Icon on the top of screen is Yellow or Red, check this status page to help identify GPS signal issues.



GPS Baudrate

Sets the baudrate at which the console communicates with the GPS receiver you are using. Available speeds are **4800, 9600, 19200, 38400, and 115200.**

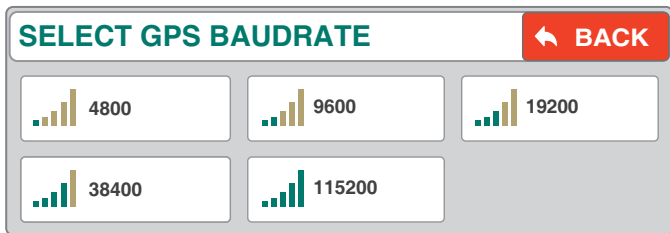
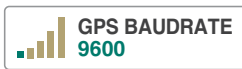

GPS Speed Correction

If your GPS is displaying an incorrect speed reading, use this screen to add the desired correction in MPH.

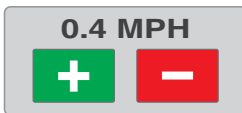
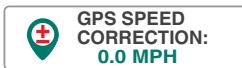

Settings Menu - Display Settings

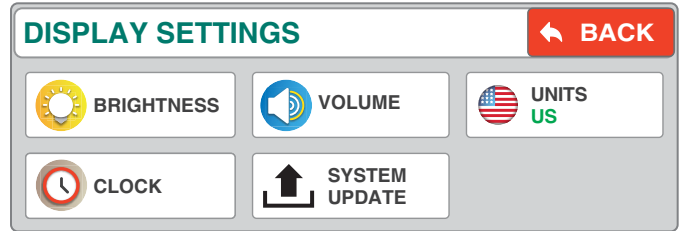

Brightness

Use the Plus or Minus keys to increase or decrease the brightness of the screen or the keypad backlight.



Volume

Use the Plus or Minus keys to increase or decrease the volume to the desired level. An audible alarm will sound with each increment.



Units

Toggles between US (feet) or Metric (meters) units.



Clock (Date & Time)

To set the time, simply select the related buttons for Month, Day, Year, Hour and Minute and enter the appropriate value into each field. Lastly toggle the time between AM or PM and push “Save” to complete.

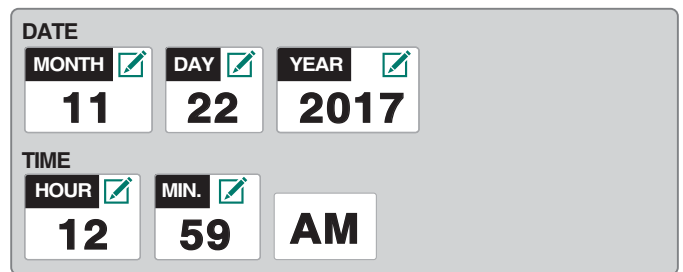

System Update

The system update screen is used to update to newer versions of software or reset to factory default settings.

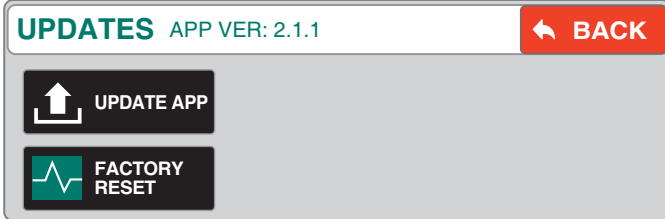

Service And Technical Support

Contact: Loup Electronics Inc.

Address: 2960 N. 38th Street
Lincoln, NE 68504

Phone: 877-489-LOUP(5687)
402-464-7131

Fax: 402-464-7104

E-mail: info@loupelectronics.com

AFTER HOURS/WEEKEND SUPPORT
402-318-6415 OR 402-853-6249

Update App

The **Update App** button is used to perform a system update to newer version of software. To update follow the following steps:



1. On a Micro SD Card, create a folder titled "**EliteUpdate**" on the root level of the MicroSD Card. Within this folder place the update file from Loup Electronics, this should appear as a **.srec** file format.
2. Insert Micro SD Card into the Elite console and select the "**Update App**" button. From the popup window select the version you wish to update, newest software versions will appear at the top of the window.
3. Allow the application to load into the console and when finished, cycle power to the console. The update will finish installation upon startup.
4. Ensure the newest software is updated by selecting the "**MENU**" button and checking the "**APP VER**" number in the upper right corner.

Factory Reset

Selecting this will reset all settings back to Factory Default. All existing implements and sensors will be removed from memory and need to be reinstalled if choosing to reset the console.



General Torque Specifications

(rev. 4/97)

This chart provides tightening torques for general purpose applications when special torques are not specified on process or drawing. Assembly torques apply to plated nuts and capscrews assembled without supplemental lubrication (as received condition). They do not apply if special graphite moly-disulfide or other extreme pressure lubricants are used. When fasteners are dry (solvent cleaned) add 33% to as received condition torque. Bolt head identification marks indicate grade and may vary from manufacturer to manufacturer. Thick nuts must be used on grade 8 capscrews. Use value in [] if using prevailing torque nuts

TORQUE SPECIFIED IN FOOT POUNDS

UNF SIZE	SAE Grade 2	SAE Grade 5	SAE Grade 8	UNF SIZE	SAE Grade 2	SAE Grade 5	SAE Grade 8
1/4-20	4 [5]	6 [7]	9 [11]	1/4-28	5 [6]	7 [9]	10 [12]
5/16-18	8 [10]	13 [13]	18 [22]	5/16-24	9 [11]	14 [17]	20 [25]
3/8-16	15 [19]	23 [29]	35 [42]	3/8-24	17 [21]	25 [31]	35 [44]
7/16-14	24 [30]	35 [43]	55 [62]	7/16-20	27 [34]	40 [50]	60 [75]
1/2-13	35 [43]	55 [62]	80 [100]	1/2-20	40 [50]	65 [81]	90 [112]
9/16-12	55 [62]	80 [100]	110 [137]	9/16-18	60 [75]	90 [112]	130 [162]
5/8-11	75 [94]	110 [137]	170 [212]	5/8-18	85 [106]	130 [162]	180 [225]
3/4-10	130 [162]	200 [250]	280 [350]	3/4-16	150 [188]	220 [275]	320 [400]
7/8-9	125 [156]	320 [400]	460 [575]	7/8-14	140 [175]	360 [450]	500 [625]
1-8	190 [237]	408 [506]	680 [850]	1-14	210 [263]	540 [675]	760 [950]
1-1/8-7	270 [337]	600 [750]	960 [1200]	1-1/8-12	300 [375]	660 [825]	1080 [1350]
1-1/4-7	380 [475]	840 [1050]	1426 [1782]	1-1/4-12	420 [525]	920 [1150]	1500 [1875]
1-3/8-6	490 [612]	1010 [1375]	1780 [2225]	1-3/8-12	560 [700]	1260 [1575]	2010 [2512]
1-1/2-6	650 [812]	1460 [1825]	2360 [2950]	1-1/2-12	730 [912]	1640 [2050]	2660 [3325]

METRIC:

Coarse thread metric class 10.9 fasteners and class 10.0 nuts and through hardened flat washers, phosphate coated, Rockwell "C" 38-45. Use value in [] if using prevailing torque nuts

Nominal thread diameter (mm)	Newton Meters (Standard Torque)	Foot Pounds (Standard Torque)	Nominal Thread Diameter (mm)	Newton Meters (Standard Torque)	Foot Pounds (Standard Torque)
6	10 [14]	7 [10]	20	385 [450]	290 [335]
7	16 [22]	12 [16]	24	670 [775]	500 [625]
8	23 [32]	17 [24]	27	980 [1105]	730 [825]
10	46 [60]	34 [47]	30	1330 [1470]	990 [1090]
12	80 [125]	60 [75]	33	1790 [1950]	1340 [1450]
14	125 [155]	90 [115]	36	2325 [2515]	1730 [1870]
16	200 [240]	150 [180]	39	3010 [3210]	2240 [2380]
18	275 [330]	205 [245]			

Hydraulic Fitting Torque Specifications

37 degree JIC, ORS, &ORB (REV. 10/97)

This chart provides tightening torques for general purpose applications when special torques are not specified on process or drawing. Assembly torques apply to plated nuts and capscrews assembled without supplemental lubrication (as received condition). They do not apply if special graphite moly-disulfide or other extreme pressure lubricants are used. When fasteners are dry (solvent cleaned) add 33% to as received condition torque. Bolt head identification marks indicate grade and may vary from manufacturer to manufacturer. Thick nuts must be used on grade 8 capscrews. Use value in [] if using prevailing torque nuts.

TORQUE SPECIFIED IN FOOT POUNDS

PARKER® BRAND FITTINGS

Dash Size	37 Deg. JIC	O-ring (ORS)	O-ring boss
-4	11-13	15-17	13-15
-5	14-16	-----	21-23
-6	20-22	34-36	25-29
-8	43-47	58-62	40-44
-10	55-65	100-110	58-62
-12	80-90	134-146	75-85
-16	115-125	202-218	109-121
-20	160-180	248-272	213-237
-24	185-215	303-327	238-262
-32	250-290	-----	310-340

GATES® BRAND FITTINGS

Dash Size	37 Deg. JIC	O-ring (ORS)	O-ring boss
-4	10-11	10-12	14-16
-5	13-15	-----	-----
-6	17-19	18-20	24-26
-8	34-38	32-40	37-44
-10	50-56	46-56	50-60
-12	70-78	65-80	75-83
-14	-----	65-80	-----
-16	94-104	92-105	111-125
-20	124-138	125-140	133-152
-24	156-173	150-180	156-184
-32	219-243	-----	-----

AEROQUIP® BRAND FITTINGS

Dash Size	37 Deg. JIC	O-ring (ORS)	O-ring boss
-4	11-12	10-12	14-16
-5	15-16	-----	16-20
-6	18-20	18-20	24-26
-8	38-42	32-35	50-60
-10	57-62	46-50	75-80
-12	79-87	65-70	125-135
-14	-----	-----	160-180
-16	108-113	92-100	200-220
-20	127-133	125-140	210-280
-24	158-167	150-165	270-360

Valve Torque Values

Part Number	Description	Torque (Ft-Lbs)
175159	Relief	24-26
171000	Shutoff	19-21

Fasteners

Before operating your Brillion machine, check all hardware for tightness. Use the Tightening Torque Table as a guide. **See Page 5-1.**

After a few hours of use, check entire machine and tighten any loose nuts or bolts. Daily or periodic checks should be made thereafter.

When replacing bolts, be sure to use fasteners of equal grade.

Tires

Recommended Tire Size: 12.5L x 15 FI

Tire Inflation Pressure: 52PSI

When Re-Installing the 5/8-18 Wheel Nuts tighten to 50 foot-pounds using the sequence in **See Figure 5-1**. Then tighten to full torque of 130-150 ft-lbs.

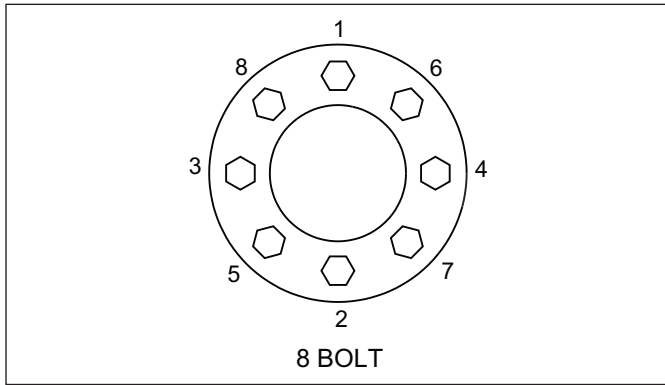

Figure 5-1: Stud Tightening Sequence

Wheel Hub Bearing Maintenance

Wheel bearing maintenance should be performed at the beginning of every season of use. Check the wheel bearings periodically for excessive end play. If needed, adjust or replace them using the following procedure:

1. Place the Frame on blocks or stands sufficient to lift the Tire clear of the ground.
2. Remove the Tire.
3. Remove the Hub Cap, Cotter Pin, Slotted Nut and Washer.
4. Remove the Hub. Clean and inspect the Bearings and Hub Cavity. Replace any worn or defective parts.
5. Repack the Bearings using a high-quality Wheel Bearing Grease.
6. Install the inner bearing into the hub and install the grease seal. Use a driver to install the seal, to avoid damaging the outer edge of the seal. Drive the seal squarely into the hub to avoid any seal distortion.

NOTE

The Triple-Lip Seal should point away from the Hub to keep contaminants out and allow grease to pass.

7. Slide the hub, bearing, and seal onto a clean spindle
8. Install the Outer Bearing Cone, Washer and Slotted Nut.
9. Tighten the Slotted Nut while rotating the Hub until there is a slight resistance to wheel rotation. Then back the Slotted Nut off one notch, until the wheel rotates freely without the end play.
10. Install a new Cotter Pin and replace the Hub Cap.

Lubrication Maintenance

The 4620-24 Folding Seeder is equipped with maintenance free bearings in the lifts and wing assemblies. These areas require no lubrication.

Roller assembly bearings are sealed with a triple lip seal and are non-lubricable.

- Grease Wheel Hubs every 50 Hours. **See Figure 5-2.**
- When the machine is not used for some time, exposed portions of the hydraulic cylinder rods must be cleaned and covered with a thick coat of grease to prevent corrosion, which will damage the seal.

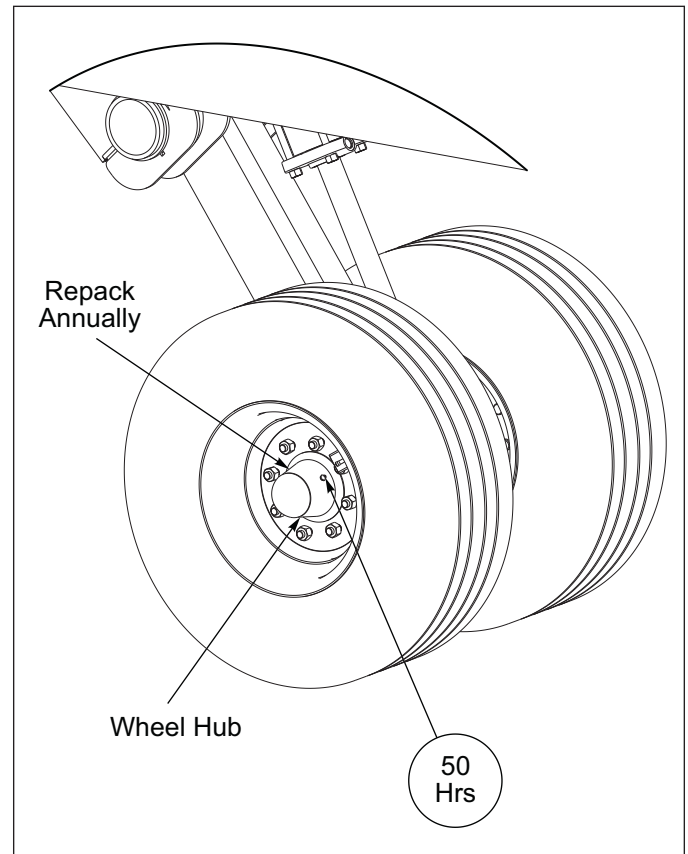

Figure 5-2: Lubrication Points and Intervals

Hydraulic Maintenance

IMPORTANT

Unfold, lower the unit to the ground, and relieve hydraulic pressure before attempting to service any hydraulic component.



WARNING

Escaping fluid under pressure can be nearly invisible and have enough force to penetrate the skin causing serious injury. Use a piece of cardboard, rather than hands to search for suspected leaks. Wear protective gloves and safety glasses or goggles when working with hydraulic system.

1. Check the hydraulic fluid level per tractor owner’s manual and after any leakage. Check hydraulic fluid level when the wings are folded and machine is raised for transport.
2. If a cylinder or valve leaks, disassemble the parts to determine the cause of the leak. Any time a cylinder is opened up, or whenever any seal replacement is necessary, it is advisable to clean all parts and replace all seals. Seal kits are available from your Brillion dealer.
3. Check all hydraulic hoses weekly. Look for binding or cracking. Replace all worn or defective parts immediately.
4. Transport locks are provided to hold the implement in a raised position. **See Figure 3-3.** Do not attempt to perform any service work under the implement without first installing the transport locks. Before servicing any hydraulic component, lower the implement to the ground and relieve all system pressure. If a hydraulic component is disconnected, repaired, or replaced, it will be necessary to purge the system of air before operation. **“Hydraulic Lift System” on page 3-4 and “Hydraulic Fold and Wing Lock System” on page 3-4** on how to purge the hydraulic systems.

Hose Identification

1. The hydraulic hoses are color coded to help identify and match the attaching hoses on the Seeder. An identification decal is placed on the front of the hitch to help identify the hoses. **See Figure 5-3.**
2. For the Seeder, hoses will be identified as follows:
 Blue - Lift Wheels
 Yellow - Wing Fold
 Black - Auxiliary (Wing Locks)

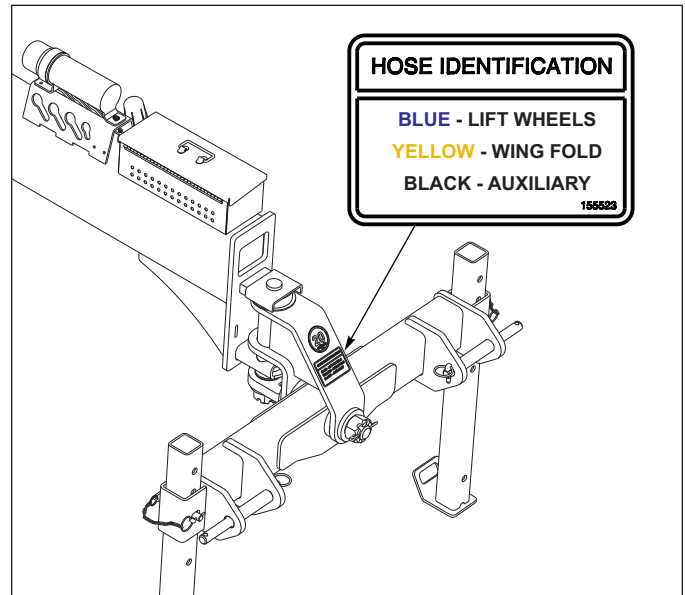

Figure 5-3: Hose Identification Decal

Front and Rear Roller Adjustment

After an initial run of 5-10 hours, check the Roller Axle Assemblies to ensure that the wheels are tight to one another. If not slide the wheels tight together and adjust the Axle Clamps.

Front Roller push wheels against welded Roller End Plate. **See Figure 5-4.**

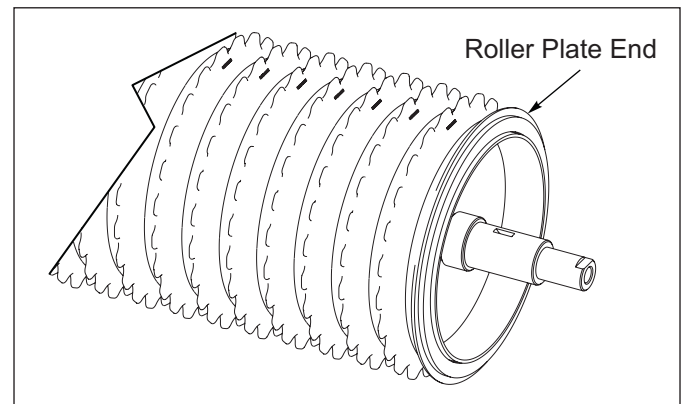

Figure 5-4: Seeder Roller

Roller Clamp Tightening

Tighten the Clamp Socket Head Bolt. Torque to 75ft/lbs. Thereafter check assemblies every 50-100 hours. See **Figure 5-5**. Clamps must be assembled with the open section straddling the welded seam of the drum pipe.

NOTE

Failure to locate the clamp band bolt over the weld will cause clamp band to loosen and slide.

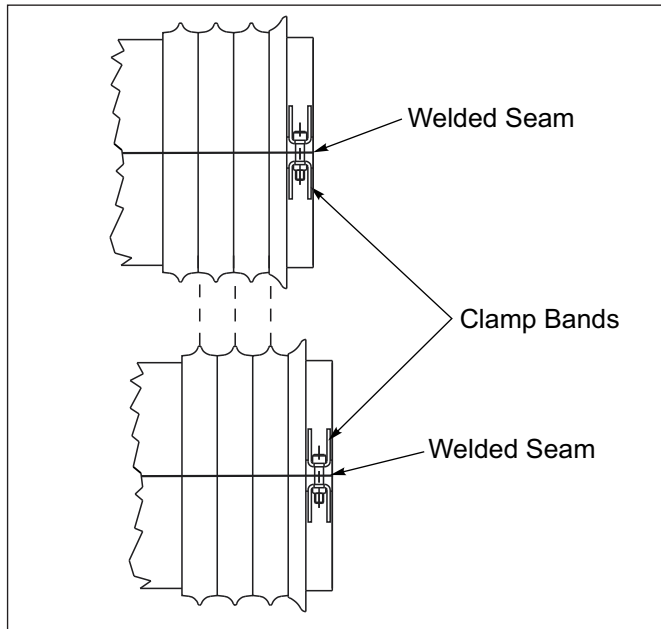

Figure 5-5: Roller Clamp Tightening

Servicing Seed Shaft Assembly

IMPORTANT

The clutch must be disengaged (power off) when Seed Shafts are turned manually.

After you have serviced a Seed Shaft, Seed Meters or related components you will need to Zero out the Seed Meters to ensure that you are seeding uniformly. Refer to Seed Meter Adjustment. The following is a list of things to be conscience of when re-assembling the Seed Shafts.

- Ensure that the Thrust Washers are adjacent to Seed Meter Feed Cut Offs and Spacers or Square Bore Collars. See **Figure 5-6**.

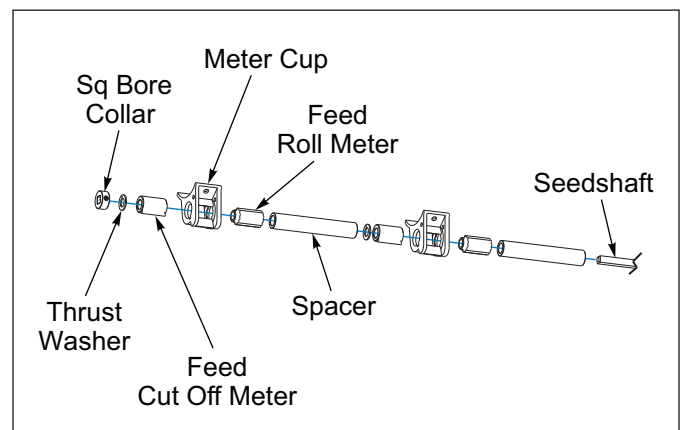

Figure 5-6: Seed Shaft Assembly

- Ensure RH Seed Shaft is threaded into the Feed Roll Coupling Assembly between 1/2" to 3/4". Seed Shaft should be visibly past the set screw hole when the set screw is removed from the Coupler. Tighten Feed Roll Coupler Assembly Set Screws against the flats of the Seed Shaft.
- Ensure that the Seed Shaft can turn freely without any binding when the Seed Meters are open or closed after servicing. You may need to make adjustments to the Seed Meter Supports at each Seed Meter.

Seed Meter Adjustment

IMPORTANT

All the Seed Meters **MUST BE CLOSED!** It may be necessary to individually adjust Seed Meter Adapter with Seed Meter attached or Seed Meter if Meter Adapter is not used.

All Seed Meters must be set the same to ensure seeding uniformity. To check, set the Seed Rate Adjusting Nut to 0-A. The "A" on the Seed Rate Adjusting Nut is positioned over the "0" (the nut covers half of the "0") and snug against the bearing. All Seed Meter Cups should be closed. If not, there are three adjustments to make as needed. See Figure 5-7.

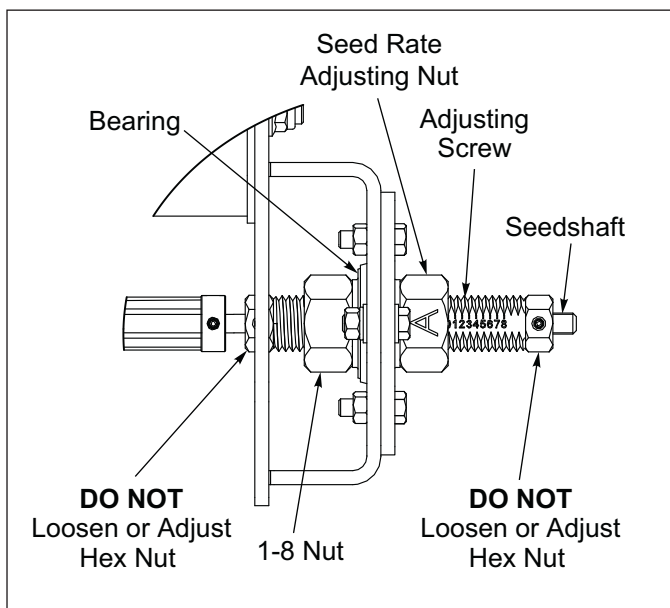

Figure 5-7: Seed Rate Adjuster

1. Hex Nuts with Set Screws on both ends of the Adjusting Screw are used to adjust all Seed Meters the same amount. See Figure 5-7. To adjust Seed Meters to be closed at "0A", loosen Hex Nuts with Set Screws (remove set screws first) and set adjusting screw to "0A". Slide Seed Shaft to close all Seed Meters. Tighten Hex Nuts with Set Screws against Adjusting Screw and install set screws to lock against Seed Shaft flats.
2. There are 4 sections of Seed Meters grouped together per Seed Box. On each end of each section there are 3/8 Square Bore Collars with Set Screws. Loosen Collar Set Screws to move that particular section as needed.

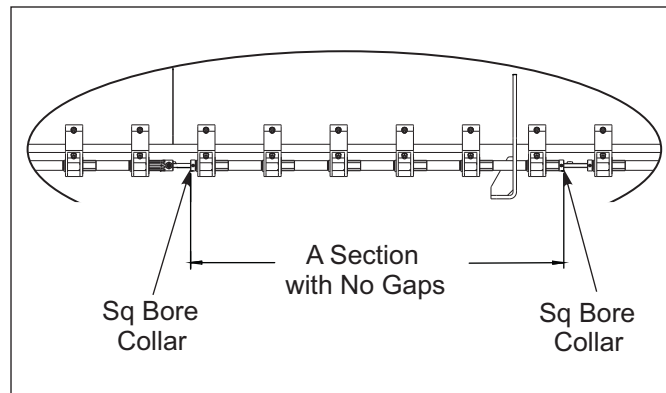

Figure 5-8: Seed Meter Section

3. Individual Seed Meter Adapters with Seed Meter Cup attached or Seed Meter Cups (if Meter Adapter is not used) can be adjusted as required. Adjustments can be made by loosening the 1/4-20 x 3/4 Machine Screws that mount the Seed Meter Adapter or Seed Meter Cup to the Seed Box and the 1/4-20 Nut that attaches the Seed Meter Support to the Seed Meter Cup. Adjust the affected Seed Meters so the Feed Cut Off is against the star washer in the Seed Meter Cup (closed). Be sure the Meter Feed Roll stays engaged in the Seed Meter Star Washer. See Figure 5-9. After adjustments have been made seal the Seed Meter Adapter to Seed Box with clear Silicone.

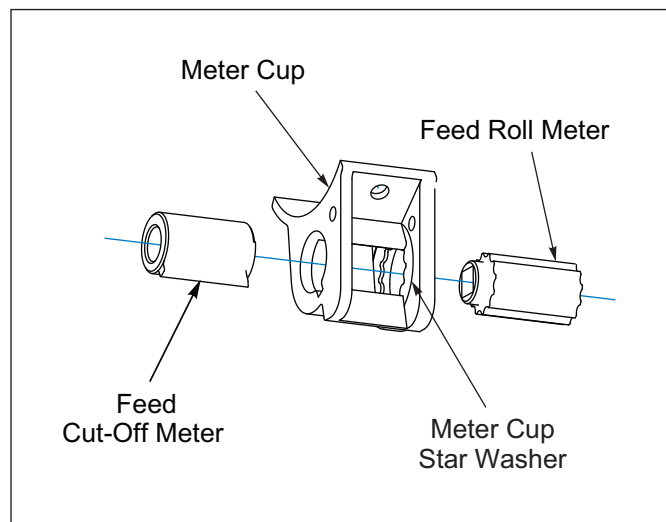

Figure 5-9: Individual Seed Meter Cup

LED Warning Lamps

When plugging in the LED 7-Pin Warning Lamp Connector:

1. Make sure the tractor has a good clean receptacle, free of dirt and corrosion.
2. Make sure the LED 7-Pin Warning Lamp Connector is inserted ALL the way in. With tighter fitting pins, operator may think the connector is all the way in, but really isn't.
3. Make sure the tractor receptacle cover latches over the keyway on the LED 7-Pin Warning Lamp Connector to hold the connector in place.

If an operator plugs in the LED 7-Pin Warning Lamp Connector, but the lights do not seem to work right, check the above items to make sure there is a good connection with the LED 7-Pin Warning Lamp Connector.

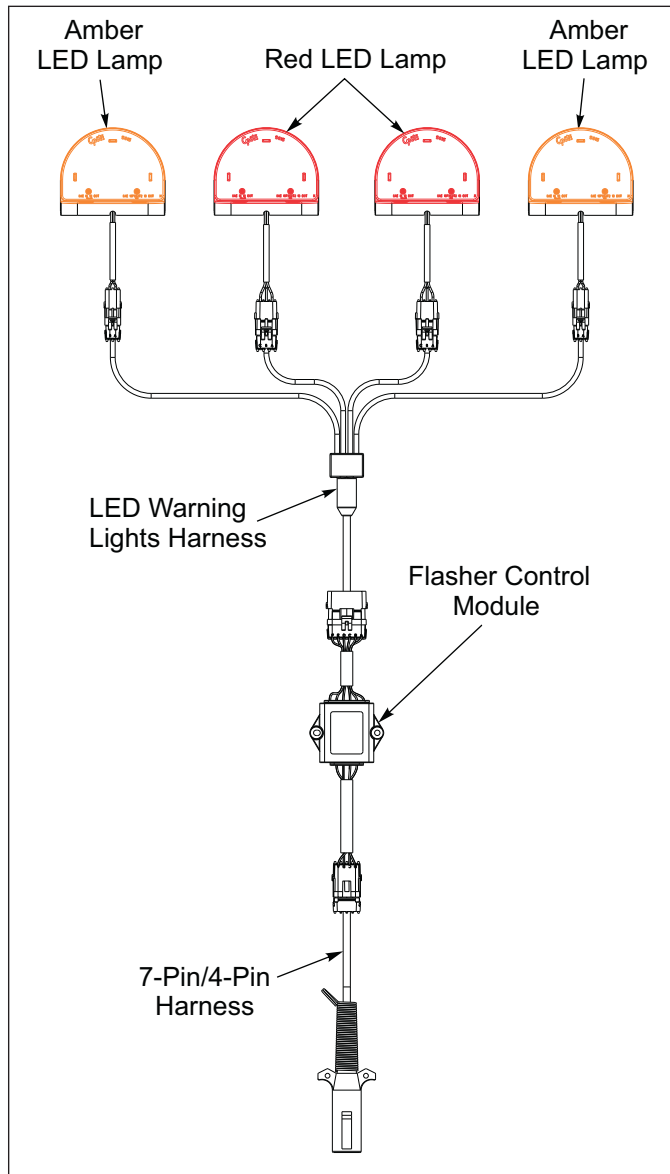

Figure 5-10: LED Warning Lamps

Storage

1. The service life of the Folding Seeder will be extended by proper off-season storage practices. Prior to storing the unit, complete the following procedures:
 - Completely clean the unit, blow all seeds out of Seed Meters.
 - Inspect the machine for worn or defective parts. Replace as needed.
 - Repaint all areas where the original paint worn off.
 - Apply a light coating of oil or grease to exposed Cylinder Rods to prevent them from rusting.
 - Lubricate each point of the machine as state in **“Lubrication Maintenance” on page 5-3.**
2. Protect the Folding Seeder from the weather by storing it in a shed or under a tarpaulin. The tires should rest on boards, or some other object, to keep them out of the soil.
3. Store the Folding Seeder folded and fully raised with Transport Locks engaged and pinned to prevent settling. **See “General Operation” on page 3-6.**
4. Relieve Hydraulic Pressure after Transport Locks are installed. Block Folding Seeder Transport Wheels before unhitching from tractor.

General Reference and Specifications

Product Attributes	SS-24
Description	24 ft. (7.3 m) Agricultural Seeder
Approximate Weight (Empty)	16,178 lbs. (7,338 kg)
Working Width	24 ft. (7.3 m)
Transport Width	13 ft. 9 in. (4.2 m)
Overall Length (Transport)	31 ft. 2 in. (9.5 m)
Hitch	Semi-Mounted Two-Point Hitch
Hitch Category	Cat. II & III Free Link; Cat. II, IIIN, III Quick Coupler
Transport Tires	(4) 12.5L x 15 FI
Hydraulic Circuits Required	3
Seed Box	All Steel Construction
Seed Box Capacity	15 Bushels (528.6 l) Each Wing
Seed Metering	Micro-Meters with 6 in. (152 mm) Spacing
Seed Metering Drive	Ground Driven with Independent Electric Seeder Clutches
Pulverizer Rollers	Cast Iron with Notched Profile
Front Roller	15.75 in. (400 mm) Diameter
Rear Roller	15.75 in. (400 mm) Diameter
Pulverizer Roller Bearings	1.75 in. (45 mm) Flange Bearing
Seeder Wings	Float 5 Degrees Left to Right and 5 Degrees Front to Rear on Torsion Springs
Pivot Points	Utilize Maintenance Free Polymer Bearings
Coil Tine Track Remover	Standard
Electronic Acre Meter Kit	Standard
LED Safety Warning Lights & SMV Emblem	Standard
Powder Coat Paint, Red	Standard
Horsepower Requirements	Minimum of 150 HP (111.8 kW)
Three-Point Hitch Lift Capacity	7,500 lbs. (3,402 kg)
Recommended Operating Speed	4.5 to 6.0 MPH (7.2 to 9.7 km/h) Dependent on Conditions

Specifications subject to change with or without notice.

Figure 6-1: Model Specifications

Document Control Revision Log:

Date	Form #	Improvement(s): Description and Comments
05/2019	F-886-0519	New Release
03/2022	F-886-0322	ECN 46900, 47187, 47696, 47707 - Add Brillion Elite Mini Monitor by Loup ECN 47474 - Add QR Code Decals Add High Powered Magnet Warning Add Brillion Elite Mini Monitor Manual Chapter



Intertek

Equipment from Landoll Company, LLC is built to exacting standards ensured by ISO 9001 registration at all Landoll manufacturing facilities.

Folding Seeder Model 4620-24 Operator's Manual

Re-Order Part Number F-886

LANDOLL COMPANY, LLC

1900 North Street

Marysville, Kansas 66508

(785) 562-5381

800-428-5655 ~ **WWW.LANDOLL.COM**



Copyright 2022. Landoll Company, LLC

“All rights reserved, including the right to reproduce this material or portions thereof in any form.”

