

# H2O-2412 Series

## Automatic Aqueous Parts Washer

### Top-Load

## Operator's Manual

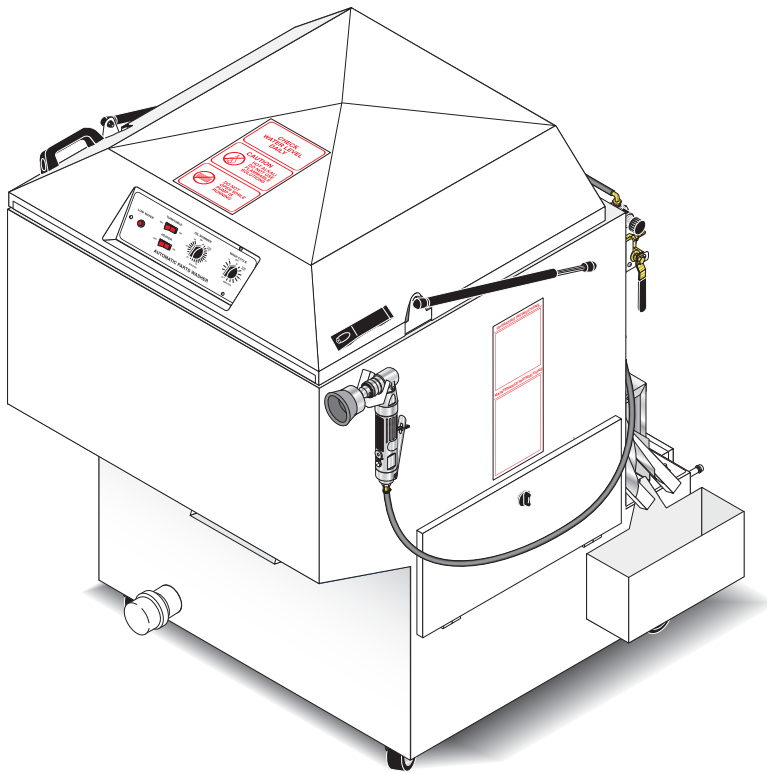

### MODELS:

H2O-2412 115V	1.043-540.0
H2O-2412 208V	1.043-541.0
H2O-2412 230V	1.043-542.0
H2O-2412 115V SS	1.043-543.0
H2O-2412 208V SS	1.043-544.0
H2O-2412 230V SS	1.043-545.0
H2O-2412 208V 2HP	1.043-546.0
H2O-2412 208V 2HP	1.043-547.0
H2O-2412 208V 2HP SS	1.043-548.0
H2O-2412 230V 2 HP SS	1.043-549.0

For the Dealer nearest you, consult  
our web page at  
[www.karchercommercial.com](http://www.karchercommercial.com)



**Machine Data Label**

---

Model: \_\_\_\_\_

Date of Purchase: \_\_\_\_\_

Serial Number: \_\_\_\_\_

Dealer: \_\_\_\_\_

Address: \_\_\_\_\_

Phone Number: \_\_\_\_\_

Sales Representative: \_\_\_\_\_

<b>Machine Data Label</b> . . . . .	<b>2</b>	Using the Oil Skimmer System . . . . .	<b>21</b>
<b>Table of Contents</b> . . . . .	<b>3</b>	<b>Troubleshooting</b> . . . . .	<b>22</b>
<b>How To Use This Manual</b> . . . . .	<b>4</b>	Troubleshooting the Electrical System . . . . .	22
		Troubleshooting the Electrical Panel . . . . .	22
		Testing Individual Components . . . . .	23
<b>Safety</b>			
Introduction & Safety Information . . . . .	5		
General Safety Information . . . . .	6		
<b>Operations</b>			
Component Identification - Front View . . . . .	8		
Component Identification - Rear View . . . . .	9		
<b>Installation</b> . . . . .	<b>10</b>		
Before You Begin . . . . .	10		
Step 1: Make Electrical Connections . . . . .	10		
Step 2: Connect A Compressed-air Line And Accessories (Optional) . . . . .	10		
Step 3: Connect A Water Line . . . . .	10		
Step 4: Fill The Machine With Water And Add Detergent . . . . .	11		
<b>Operations</b> . . . . .	<b>12</b>		
Main Operating Components . . . . .	12		
Control Panel . . . . .	12		
Low Water Indicator . . . . .	12		
Turntable Switch . . . . .	12		
Heater Control . . . . .	12		
Wash Cycle Control . . . . .	12		
Thermostat . . . . .	12		
Turntable Assembly . . . . .	13		
Using the Power Brush . . . . .	14		
Adjusting the Flow of Cleaning Solution . . . . .	14		
Low Water Shut-off System . . . . .	15		
Detergents And Additives . . . . .	15		
<b>Preparing The Machine For Use.</b> . . . . .	<b>16</b>		
Washing Parts . . . . .	16		
Shutting Down The Machine . . . . .	16		
<b>Maintenance</b>			
<b>Maintaining The Machine</b> . . . . .	<b>17</b>		
Daily Maintenance . . . . .	17		
Weekly Maintenance . . . . .	17		
Monthly Maintenance . . . . .	17		
Cleaning and Aligning the Spray Nozzles . . . . .	17		
Cleaning out the Sump . . . . .	18		
<b>Repairing The Machine</b> . . . . .	<b>18</b>		
Heating Element . . . . .	18		
Thermostat . . . . .	19		
Timers and Switches . . . . .	19		
Torque Limiter . . . . .	20		
Turntable Motor . . . . .	20		

## How To Use This Manual

This manual contains the following sections:

- How to Use This Manual
- Safety
- Operations
- Maintenance
- Parts List

The HOW TO USE THIS MANUAL section will tell you how to find important information for ordering correct repair parts.

Parts may be ordered from authorized dealers. When placing an order for parts, the machine model and machine serial number are important. Refer to the MACHINE DATA box which is filled out during the installation of your machine. The MACHINE DATA box is located on the inside of the front cover of this manual.

Model: _____
Date of Purchase: _____
Serial Number: _____
Dealer: _____
Address: _____
Phone Number: _____
Sales Representative: _____

The model and serial number of your machine are located on the back of the machine.

The SAFETY section contains important information regarding hazardous or unsafe practices of the machine. Levels of hazards are identified that could result in product damage, personal injury, or severe injury resulting in death.

The OPERATIONS section is to familiarize the operator with the operation and function of the machine.

The MAINTENANCE section contains preventive maintenance to keep the machine and its components in good working condition. They are listed in this general order:

- Maintaining The Machine
- Daily Maintenance
- Weekly Maintenance
- Monthly Maintenance
- Cleaning And Aligning The Spray Nozzles
- Cleaning Out The Slump
- Repairing The Machine
- Heating Element
- Thermostat
- Timers and Switches on The Control Panel
- Torque Limiter
- Turntable Motor
- Using The Oil Skimmer System
- Troubleshooting

The PARTS LIST section contains assembled parts illustrations and corresponding parts list. The parts lists include a number of columns of information:

- **REF** – column refers to the reference number on the parts illustration.
- **PART NO.** – column lists the part number for the part.
- **QTY** – column lists the quantity of the part used in that area of the machine.
- **DESCRIPTION** – column is a brief description of the part.
- **NOTES** – column for information not noted by the other columns.

*NOTE: If a service or option kit is installed on your machine, be sure to keep the KIT INSTRUCTIONS which came with the kit. It contains replacement parts numbers needed for ordering future parts.*

*NOTE: The manual part number is located on the lower right corner of the front cover.*

## **Introduction & Safety Information**

This manual is intended as a guide for safely installing, operating and maintaining your Automatic Parts Washer.

We reserve the right to make changes at any time without incurring any obligation.

### **Owner/User Responsibility:**

The owner and/or user must have an understanding of the manufacturer's operating instructions and warnings before using this machine. Warning information should be emphasized and understood. If the operator is not fluent in English, the manufacturer's instructions and warnings shall be read to and discussed with the operator in the operator's native language by the purchaser/owner, making sure that the operator comprehends its contents.

Owner and/or user must study and maintain for future reference the manufacturers' instructions.

### **Save these Instructions**

This manual should be considered a permanent part of the machine and should remain with it if machine is resold.

When ordering parts, please specify model and serial number. Use only identical replacement parts.

This machine is to be used only by trained operators.

## General Safety Information



**WARNING:** To reduce the risk of injury, read operating instructions carefully before using.

**AVERTISSEMENT:** Pour réduire le risque de blessures, lire attentivement les instructions de fonctionnement avant l'utilisation.

1. Read the owner's manual thoroughly. Failure to follow instructions could cause a malfunction of the parts washer and result in death, serious bodily injury and/or property damage.



**WARNING:** This is a heated parts cleaner. Use only nonflammable, noncombustible, water-based cleaning compounds in this machine. Do not fill or contaminate with any flammable or combustible material such as gasoline, alcohol, mineral spirits, etc. Drain parts to be cleaned of any combustible or flammable

material before placing inside cabinet. Failure to observe this warning will create an extremely hazardous condition.

**AVERTISSEMENT:** Ceci est un nettoyant pour les pièces chauffées. Utiliser uniquement des produits de nettoyage à base d'eau, ininflammable et non combustible dans cette. Ne pas remplir ou contaminer avec une substance inflammable ou combustible comme de l'essence, de l'alcool, de l'essence minérale, etc. Drainer les pièces à nettoyer de toute substance combustible ou inflammable avant de les placer à l'intérieur de l'armoire. Le non-respect de cet avertissement créera une condition extrêmement dangereuse.



**DANGER:** Keep water away from electric wiring or fatal electric shock may result.

**DANGER:** Garder le jet d'eau à l'écart de tout câblage électrique ou des chocs électriques mortels pourraient survenir.

2. All installations must comply with local codes. Contact your

electrician, plumber, utility company or the selling dealer for specific details.

Install the machine in compliance with the National Electric Code. Connect to a properly sized lockable disconnect and ground machine using the grounding stud inside the main electrical panel.

3. Do not locate this machine in the vicinity of any flammable vapor, liquids or solids.
4. To protect the operator from electrical shock, the machine must be electrically grounded. It is the responsibility of the owner to connect this machine to a grounded receptacle of proper voltage and amperage ratings. Do not touch machine with wet hands or while standing in water. Always disconnect the power before servicing.
5. Do not touch machine with wet hands or while standing in water. Always disconnect the power before servicing.
6. Never make adjustments on machine while it is in operation except those prescribed in this manual.



**WARNING:** Use extreme caution when opening the door of this parts washer. Hot water/detergent vapors will be emitted. Stand Back! Hot cleaning solution could cause serious injury.

**AVERTISSEMENT:** Faire preuve d'extrême prudence au moment d'ouvrir le volet de cette partie de la laveuse. De l'eau chaude/des vapeurs de détergent seront émises. Se tenir à l'écart! Une solution de nettoyage chaude haute pression pourrait causer des blessures graves.

7. Before servicing the machine, refer to all safety data sheets (SDS's) on the material identified in the waste stream. You must comply with all warnings and wear all protective clothing stated on the SDS.

**WARNING:** Slips and falls from wet surfaces could cause serious injury.

**AVERTISSEMENT:** Les chutes et les trébuchements causés par des surfaces humides pourraient causer des blessures graves.

8. Use caution when lifting items in and out of parts basket to prevent back injuries.

9. When the machine is working, do not cover or place in a closed space where ventilation is insufficient. Avoid installing machines in small confined areas.
10. In cold climates, this parts washer will freeze if not in operation and must be located in a heated enclosure.
11. Maintain an unobstructed work area around the machine and keep the floor free of water, oil, grease or other foreign substances.
12. Always ensure that your parts washer is clean. Pump and heating elements could be damaged by continued build-up of sludge.
13. Check water level daily. Never allow water level to drop below pump inlet screen or heating elements.
14. Before discarding the spent washing solution, check with your local EPA or sewer district for disposal regulations.
15. Do not operate the machine with the lid or door open and do not override the safety switch.
16. After the machine stops, wait 10 seconds before opening the lid or door.

This automatic parts washer is designed to operate safely and efficiently. Before you begin to install and use the machine, please familiarize yourself with the major components.

***WARNING: This equipment incorporates electrical parts that tend to produce arcs or sparks. Therefore, when located in a garage, it should be installed 18" (457mm) or more above the floor.***

***AVERTISSEMENT: Cet équipement comprend des pièces qui ont tendance à produire des étincelles et, par conséquent, lorsqu'il se trouve dans un endroit comme un garage, qui utilise des produits inflammables, il devrait se trouver dans une pièce ou une enceinte prévue à cet effet ou devrait se trouver à 18 cm (457 po) ou plus au-dessus du sol.***

# Operations

## Component Identification - Front View

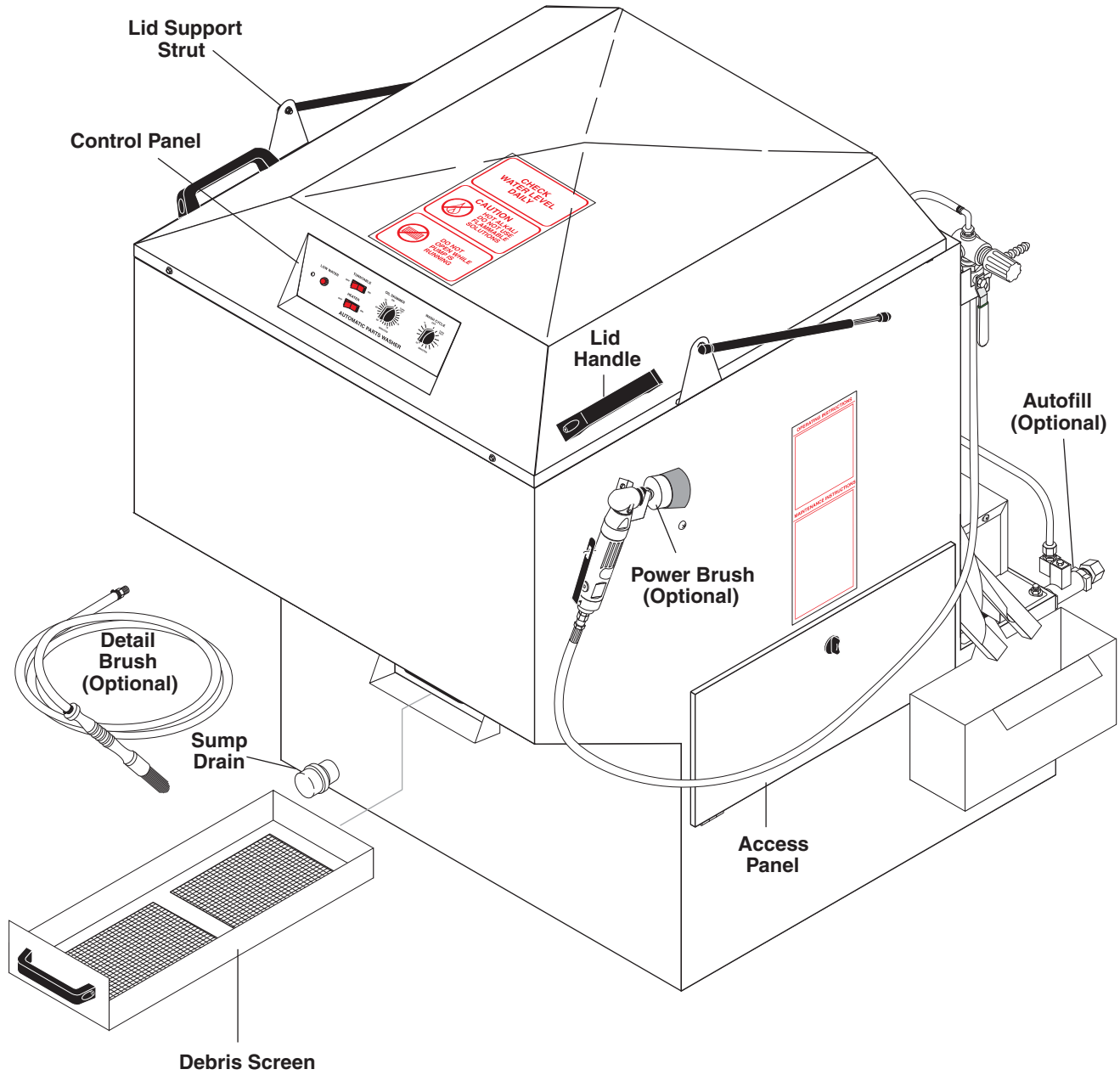



**Component Identification - Rear View**

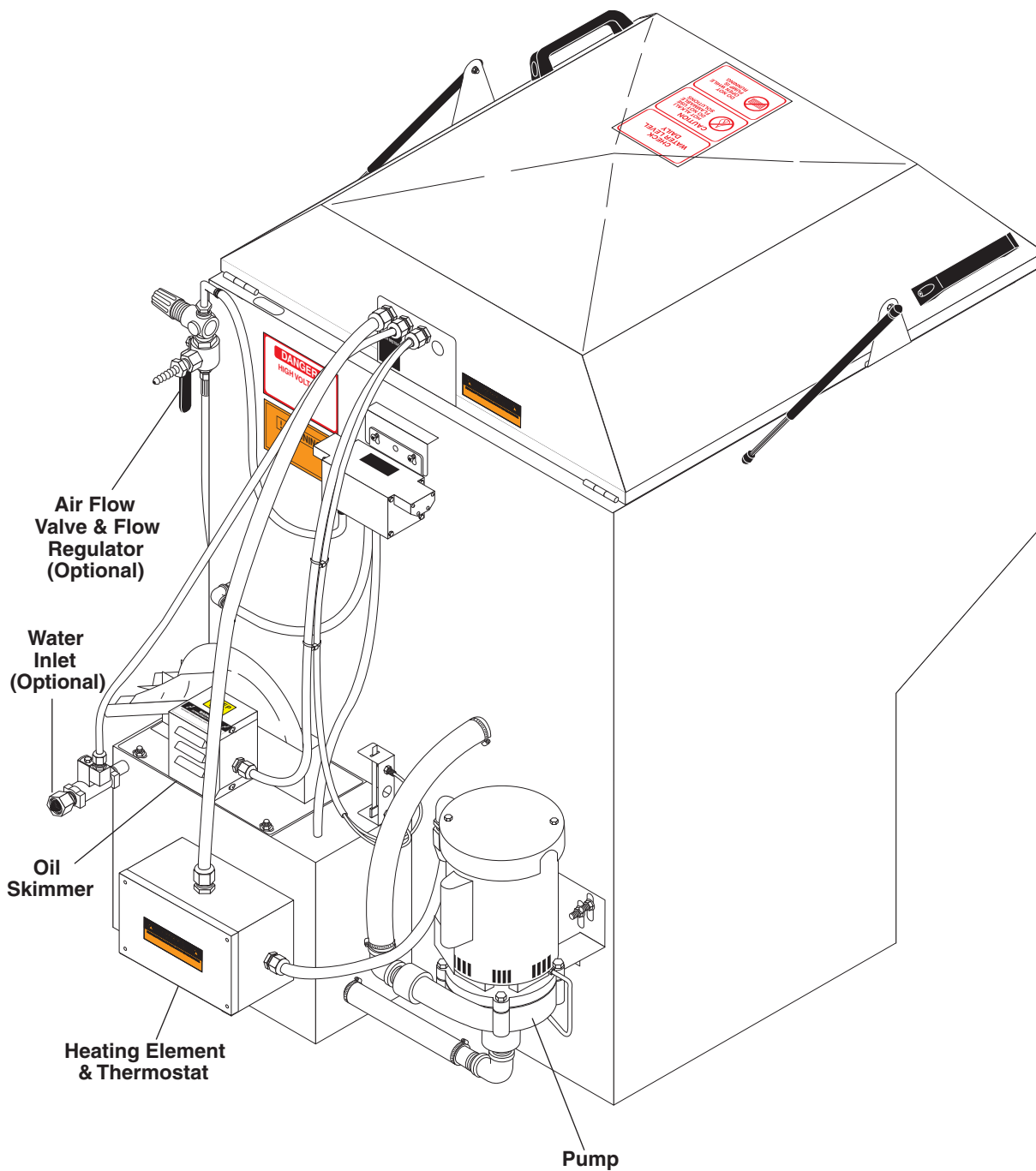

## Operations

### Installation

#### Before You Begin

To prepare to install the machine, choose an unobstructed, level site that allows convenient access for operators and maintenance personnel. Sources for water and electrical power should be located near the installation site. **If your machine is equipped with the optional power brush and hand detail brush you must also run a compressed air line to the installation site.**

If you have any questions regarding the installation, please contact your dealer and have the machine identification number available for the dealer to reference. Your machine identification tag is located inside the front cover of this manual for detailed machine specifications.

#### Step 1: Make Electrical Connections

*NOTE: All electrical installation tasks must be performed by a licensed, professional electrician to ensure safe and proper operation. The installation must comply with the National Electric Code and all applicable state and local codes.*

The machine can only operate on the type of electrical power indicated on the machine identification tag. Read and understand the machine identification tag to determine the electrical power requirements before installing the machine.

#### Step 2: Connect A Compressed-air Line And Accessories (Optional)

This step is required for machines equipped with the optional power brush and hand detail brush.

If your machine does not have these options, skip the following procedure.

*NOTE: To ensure proper operation and to minimize the possibility of premature component failure, make sure the compressed air is supplied at 75 to 90 psi. We also recommend an in-line moisture trap and an in-line lubricator on the main air supply line. Refer to the documentation provided with the power brush for more information.*

1. Remove the power brush from the box, install the wire brush in the chuck, and connect the air hose.

2. Familiarize yourself with the three-way air flow valve, then install a fitting (if necessary) to accommodate a connection to your compressed-air supply.

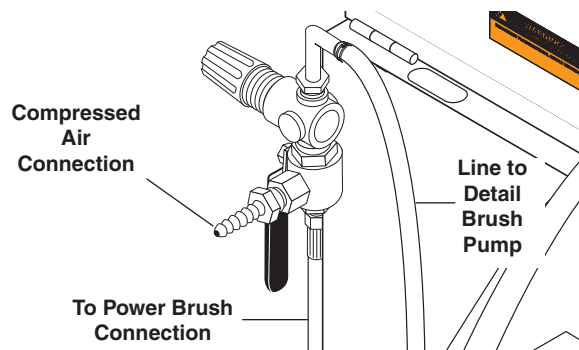

3. Connect the shop compressed-air line to the machine.
4. Connect the hose from the power brush to the air flow valve.
5. Hang the power brush on the bracket mounted along the right side of the machine.

#### Step 3: Connect A Water Line

This step is required for machines equipped with the optional automatic water fill feature. If your machine does not have this option, skip this step.

The optional automatic water fill feature automatically maintains the correct water level in the sump. The feature requires that you connect the machine to a dedicated water supply line.

To connect the machine to a water supply line, attach a suitable burst-proof hose to the hose connection on the rear of the machine, then connect the hose to a nearby water spigot.

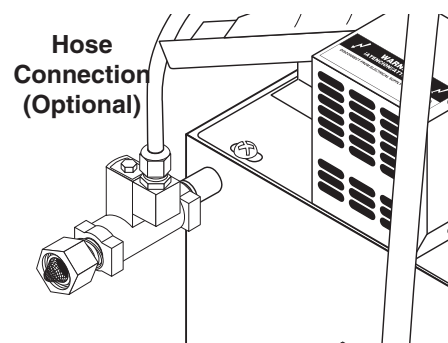

*NOTE: The machine is designed for portability, and some maintenance tasks require that you move the machine. DO NOT make a permanent connection from your shop water supply to the machine.*

## Step 4: Fill The Machine With Water And Add Detergent

1. Familiarize yourself with the low water shut-off system on the left side of the machine.

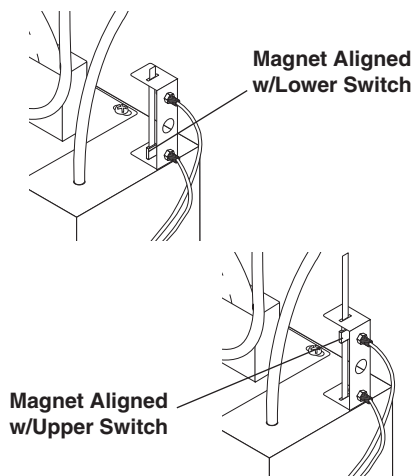

2. Fill the sump with water.

If your machine is equipped with the optional automatic water fill feature, simply turn the water on; the automatic water fill feature will automatically turn off the water when the sump is full. If your machine is not equipped with optional automatic water fill feature, add water through the wash chamber until the low water shut-off system indicates that the sump is full. The sump capacity is 25 gallons.

3. Close the lid.
4. Flip the heater switch to the **ON** position.

The sump water will reach operating temperature (160°-180°F Excludes 120V Version 1.043-540.0 & 1.043-543.0) in approximately four hours.

To avoid having to wait for the wash solution to heat up before you use the machine each day, install an optional 24-hour 7-day heater timer. Refer to 24-hour, **7-day Heater Timer** for more information.

**IMPORTANT:** Allow the sump water to reach operating temperature before adding detergent and running the machine. If you add detergent and run the machine when the sump water is cool, the detergent will foam excessively and could overflow the machine.

5. While the sump water is heating, add the appropriate quantity of factory approved detergent to the wash chamber. We recommend mixing the detergent with warm water in a separate bucket/

container and then pouring the dissolved detergent into the sump.

*NOTE: Factory approved detergent is the only detergent approved for use with this automatic parts washer. It is specially formulated with rust inhibitors and anti-foaming agents to optimize performance and minimize maintenance. The use of any other detergent during the warranty period will void the warranty. In addition, using factory detergents will extend your 90 day labor warranty to 1 year.*

6. Turn the wash cycle timer and allow the machine to complete the cycle to dissolve the detergent into the water. When the machine stops, it is ready for use. Refer to **Operation** for complete operating instructions.

## Operations

### Main Operating Components

Familiarize yourself with the main operating components before operating the machine.

### Control Panel

The control panel is located on the front center of the lid. It contains the heater, wash cycle, turntable controls, and low water indicator.

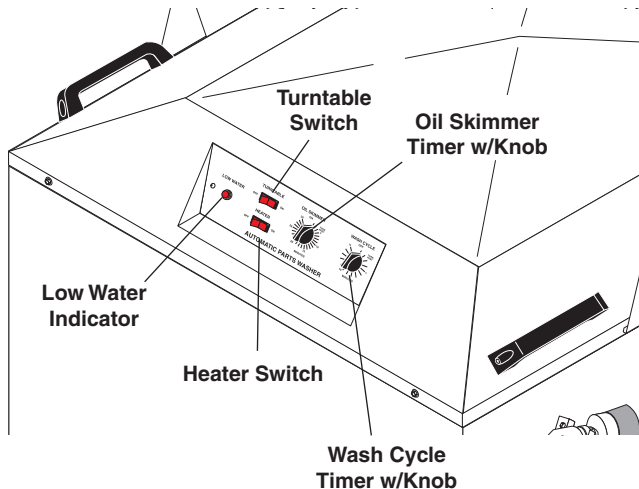

### Low Water Indicator

The low water indicator light illuminates if the wash solution in the sump is low. For more information refer to **Low Water Shut-off System**.

### Turntable Switch

The turntable switch is an illuminated rocker switch that enables you to disconnect power to the turntable motor. Set to **ON**, the turntable rotates during the wash cycle. Set to **OFF**, the turntable does not rotate during the wash cycle. The switch is useful for washing large parts that would otherwise impede turntable rotation.

### Heater Control

The heater control is an illuminated rocker switch. It controls the heating element in the sump chamber. The heater control illuminates when the heating system is on. The heating system is thermostatically set at the factory to reach a high temperature of 180 °F (Excludes 120V Version 1.043-540.0 & 1.043-543.0). The temperature is adjustable using the thermostat (See **Thermostat**).

*NOTE: The machines contain an internal power relay that automatically disconnects power to the heater when the pump turns on; the heater and pump cannot run simultaneously (120V only). After long wash cycles it may be necessary to let the machine sit idle*

*for a period of time to allow the wash solution to reheat to operating temperature.*

### Wash Cycle Control

The wash cycle control is a timer switch. When set, the timer automatically shuts off the pump and turntable when the wash cycle is complete.

### Thermostat

The thermostat is located inside pump enclosure. The thermostat is factory-set to heat the wash solution to a maximum temperature of 180°F (Excludes 120V Version 1.043-540.0 & 1.043-543.0).

### Adjusting the Thermostat

To adjust the thermostat, rotate the adjustment screw or knob clockwise to increase the temperature, or counterclockwise to decrease the temperature.

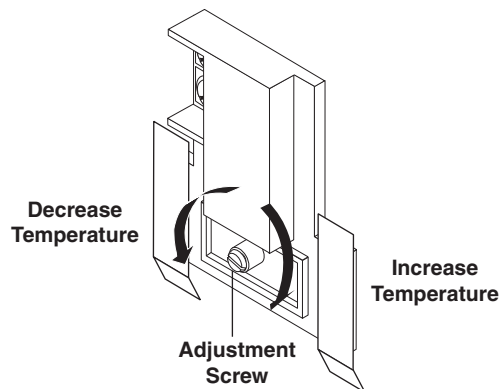

### 24-hour, 7-day Heater Timer (Optional)

A 24-hour, 7-day heater timer is available as an option on these machines. The timer plugs directly into a 15-amp outlet and automatically cycles the heating system on and off each day. To configure the timer, refer to the instructions printed on the back of the timer housing.

To order a 24-hour, 7-day heater timer, contact your dealer or call customer service.

### Lid Safety Switch

The lid safety switch is located behind the front left lip of the lid, just below the control panel. The safety switch disconnects power to the water pump and the turntable motor if the lid is raised during operation.

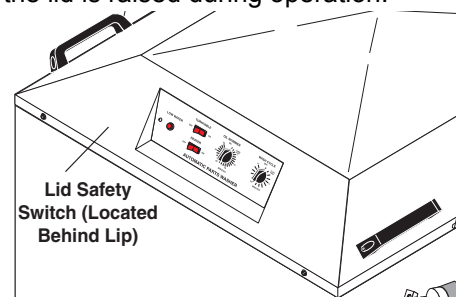

## Turntable Assembly

The turntable assembly uses a torque arm mounted on the underside of the lid to rotate the turntable. The torque arm includes a torque limiter which prevents the turntable motor from burning out in case a part falls off the turntable and obstructs rotation. For information on adjusting the torque limiter, refer to **Torque Limiter**. For information on replacing the turntable motor, refer to **Turntable Motor**.

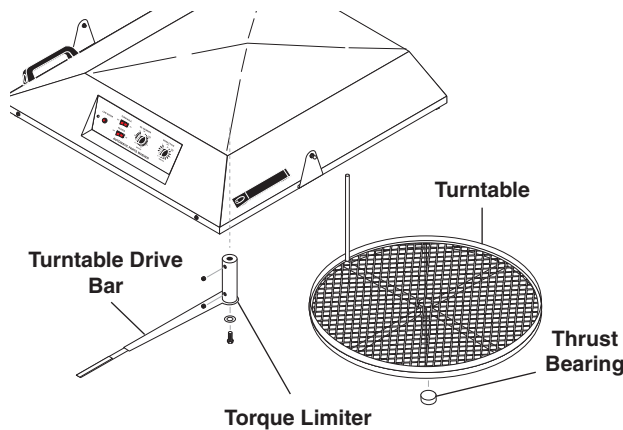

## Removing the Turntable

To remove the turntable, grasp it evenly on opposite sides and lift it free of the spindle.

**Important:** The turntable rotates on a thrust bearing inside of the hub. As you lift the turntable free of the spindle, take care not to jar the thrust bearing loose. If the thrust bearing drops out of the hub, inspect it for wear then either replace it or re-install it.

## Debris Screen

The debris screen is located below the turntable inside of the wash chamber. The debris screen continuously filters debris particles from the cleaning solution to ensure blockage free spray nozzle operation, and also provides a safeguard against small parts that might accidentally be washed through from the wash chamber.

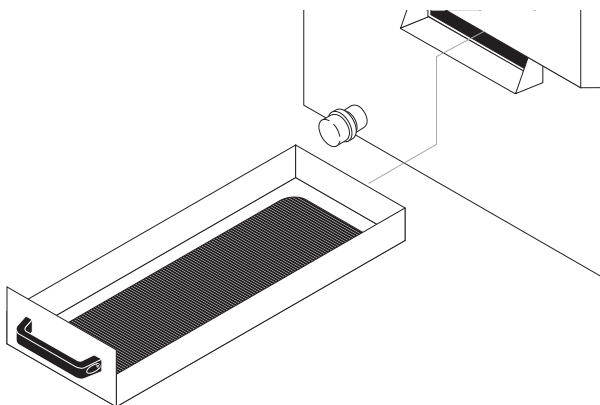

The frequency at which you must clean the debris screen depends on machine usage. In general, you should clean the screen before operating the machine each day. To access and remove the screen you must remove the turntable (see **Removing the Turntable**).

**NOTE:** Never operate the machine without the debris screen in place. The screen is specially sized to filter particles that could clog the spray nozzles or damage the water pump. **Operating the machine without the debris screen in place could cause spray nozzle clogging or water pump failure.**

## Air Flow Valve (Optional)

The air flow valve is located on the right rear corner of the machine. It is a three-way ball valve that controls the flow of compressed air to the power brush and the hand detail brush.

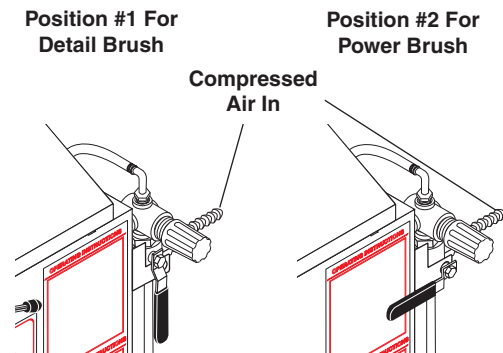

## Power Brush (Optional)

The power brush is located on the right front corner of the machine. Refer to **Connect a Compressed-Air Line and Accessories** for detailed installation information.

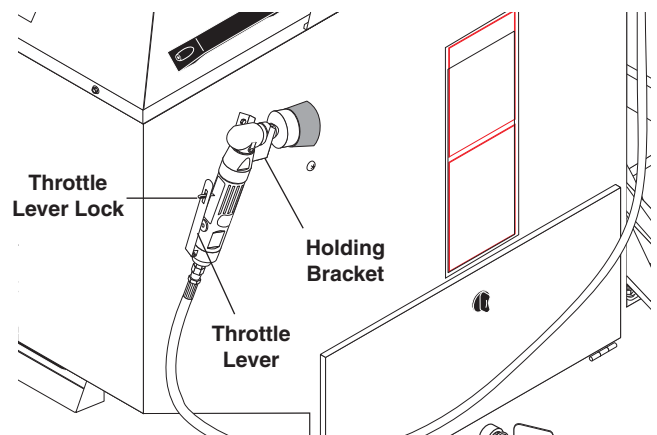

**NOTE:** The power brush is available as an option on this machine. For ordering information, contact your dealer or call customer service.

## Operations

### Using the Power Brush

**WARNING: Particles dislodged by the power brush could cause serious injury to your eyes. Always wear approved eye protection when using the power brush.**

**AVERTISSEMENT: Les particules délogées par la brosse motorisée pourraient causer des blessures graves aux yeux. Toujours porter une protection oculaire approuvée lors de l'utilisation de la brosse motorisée.**

With stiff stainless steel bristles turning at 1800 RPM, the power brush easily removes carbon deposits, old gasket material, or other tightly-adhered materials from parts before washing.

To turn on the power brush, position the air flow select valve appropriately, then push the power brush lever lock forward with your thumb and squeeze the throttle lever to control the speed of the brush.

### Detail Brush and Flow Regulator (Optional)

The detail brush is located on the front inside wall of the wash chamber. The flow regulator is located on the right rear corner of the machine. The detail brush uses a continuous flow of hot cleaning solution through its nylon bristles to help you clean delicate or lightly soiled parts. The flow regulator controls the flow of cleaning solution through the detail brush.

**WARNING: Hot, high-pressured cleaning solution could cause serious injury. Always wear rubber gloves and approved eye protection when handling hot cleaning solution.**

**AVERTISSEMENT: Une solution de nettoyage chaude haute pression pourrait causer des blessures graves. Toujours porter des gants en caoutchouc et une protection oculaire approuvée lors de la manutention de solution de nettoyage chaude.**

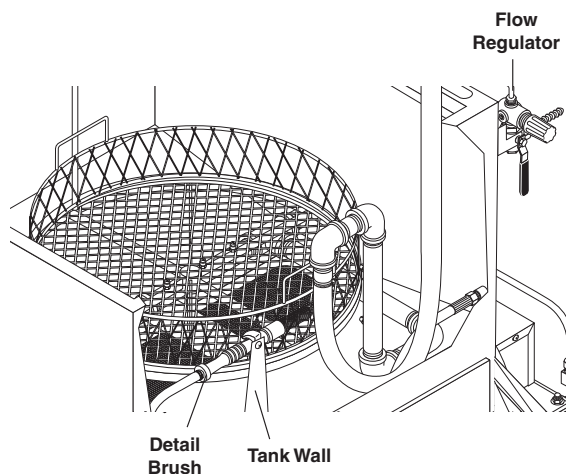

### Adjusting the Flow of Cleaning Solution

The flow of cleaning solution through the detail brush is pre-set at the factory. If you need to adjust the flow, pull out the flow regulator knob, then rotate it clockwise to decrease the flow or counter-clockwise to increase the flow. After adjusting, push the knob back in to lock it.

**NOTE: The detail brush is available as an option on this machine. For ordering information, contact your dealer or call customer service.**

### Automatic Oil Skimmer System

The automatic oil skimmer system consists of a skimmer assembly that includes an electric motor that rotates a disk in the sump water. The oil adheres to the disk and is wiped off by wiper blades and deposited in a container. The gear motor is controlled by a timer switch on the control panel. See information in Section 5 for detailed operation.

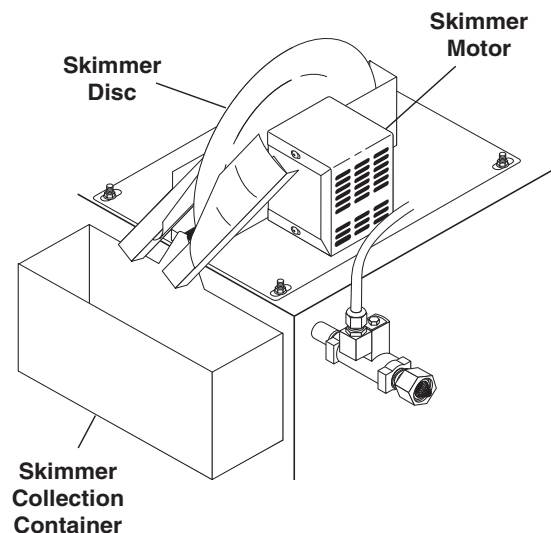

**WATER LEVEL OK:**  
Both Switches OPEN, Automatic Water Fill Valve (if installed) CLOSED, Heating Element ON.

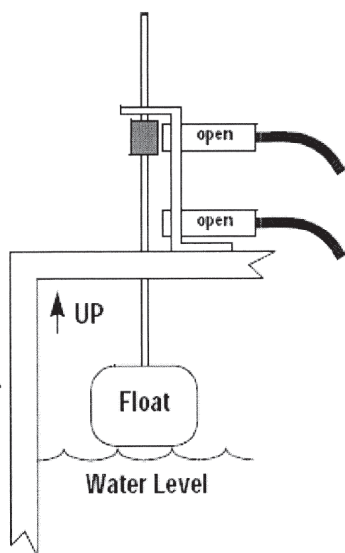

**LOW WATER LEVEL**  
Top Switch CLOSED, Bottom Switch CLOSED, Automatic Water Fill Valve (if installed) OPEN, Heating Element Off.

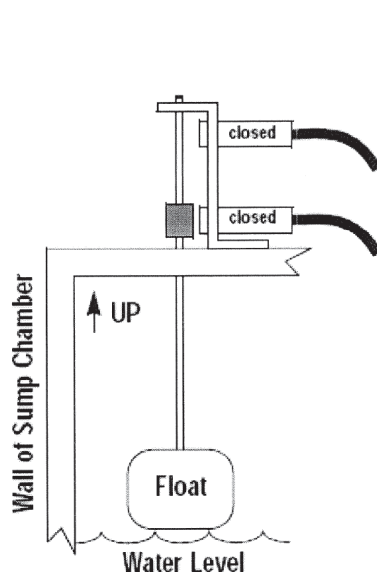

**SUMP FILLING:**  
Top Switch CLOSED, Bottom Switch OPEN, Automatic Water Fill Valve (if installed) OPEN, Heating Element Off.

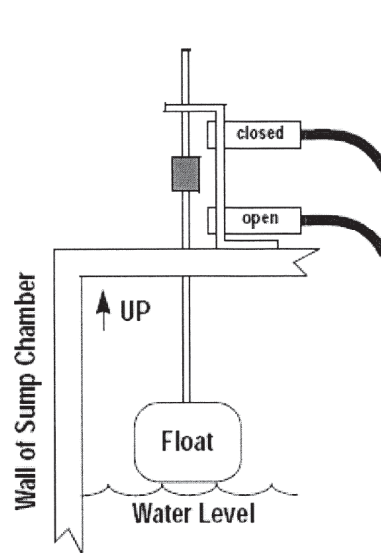

### Low Water Shut-off System

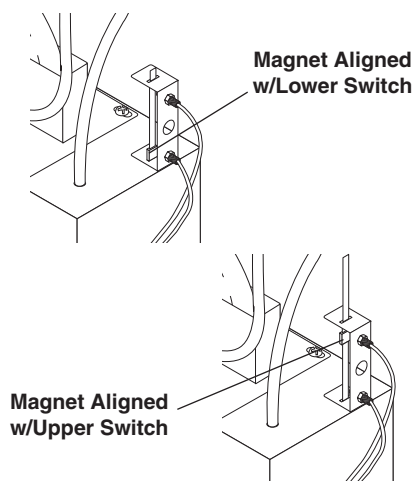

The low water shut-off system shuts down the machine if the wash solution in the sump chamber drops below a safe level. The system uses two reed switches and a float rod mounted on the right outer wall of the sump chamber to control the water level.

If the wash solution drops below the lower reed switch, the low water indicator light on the control panel turns on and the system disconnects power to the heating element, the pump, and the turntable motor. To reset the system, add water to the sump until the low water indicator light turns off.

### Automatic Water Fill (Optional)

The automatic water fill system automatically maintains a proper water level in the sump. It is available as an option on these machines.

The automatic water fill system uses the low water shut-off reed switches to open and close a water solenoid valve, which automatically maintains a proper water level in the sump. The figure above describes the operation of the automatic water fill system.

### Detergents And Additives

#### Detergents

Manufacturer's detergents are the only detergents approved for use with our Automatic Parts washers. They are specially formulated with rust inhibitors and anti-foaming agents to optimize performance and minimize maintenance. The use of any other detergent during the warranty period will void the warranty.

To monitor the relative concentration of the detergent in the wash solution, periodically examine the wash solution in the sump chamber for the following indicators:

- **Rust inside the machine:** not enough detergent
- **Excessive foaming:** not enough detergent
- **Thick, white residue on parts after washing:** too much detergent

## Operations

To maintain proper detergent concentration under typical operating conditions, add detergent each month after cleaning the sump chamber. Follow recommended detergent quantities. Use pH kit to determine the proper amount of detergent to use. If you need help interpreting test results, contact customer service.

### Rust Inhibitor Additive

Factory detergents protect the entire inside of your machine against the degenerative effects of water evaporation. A rust inhibitor additive actually evaporates with the water and continuously coats and protects metal surfaces, even while your machine is sitting idle. For more information, contact your dealer or call customer service.

### Preparing The Machine For Use

Before you begin to wash parts, it is important that you properly prepare the machine. Before you begin to use the machine each day:

- check the water level and add water to the sump tank if necessary;
- heat the water to operating temperature
- add detergent if necessary (see **Detergents and Additives**);
- verify that none of the spray nozzles are clogged; and
- clean the debris screen.

### Washing Parts

The following procedure assumes that the heater is on and the sump water is at operating temperature.

To wash parts, perform the following procedure.

**WARNING: Hot, high-pressured cleaning solution could cause serious injury. Always wear rubber gloves and approved eye protection when loading and unloading the machine.**

**AVERTISSEMENT: Une solution de nettoyage chaude haute pression pourrait causer des blessures graves. Toujours porter des gants en caoutchouc et une protection oculaire approuvée lors de la manutention de solution de nettoyage chaude.**

1. Load large, heavy parts directly onto the turntable. Load small, light parts in the small parts basket, if available. Make sure none of the parts extend beyond the edge of the turntable and make sure

large, light parts (valve covers, for example) are secured to the turntable.

*NOTE: For optimum cleaning performance, provide a slight clearance between parts to allow adequate flow of cleaning solution around and between them.*

2. Close the lid.

*NOTE: If you are washing large parts that might impede turntable rotation, flip the turntable switch OFF.*

3. Set the wash cycle timer.
4. When the machine stops, lift the lid and wait a few moments to allow the parts to cool and dry before removing them. Most parts flash-dry in seconds.

### Shutting Down The Machine

To shut down the machine at the end of the day:

- set the wash cycle control to **OFF**;
- shut off the compressed air at the supply line (if installed).

#### WARNING

- **For periods of extended shut-down (weekends and holidays, for example), disconnect power to the machine.**
- **If your machine is equipped with an optional programmable heater timer, periodically verify the settings to prevent inadvertent unattended operation.**

#### AVERTISSEMENT

- **Pendant des périodes d'arrêt prolongées (fin de semaine et jours fériés par exemple), débrancher l'alimentation de la machine.**
- **Si la machine est équipée d'une minuterie de chauffe-eau programmable en option, vérifier périodiquement les paramètres pour prévenir un fonctionnement involontaire sans surveillance.**



## Maintaining The Machine

To ensure optimum performance and trouble-free operation, observe the following maintenance schedule consistently.

### Daily Maintenance

- Check the water level; add water if necessary.
- Clean the debris screen.

### Weekly Maintenance

- **Detergent Concentration Level:** Check detergent level weekly to maintain concentration level, which decreases when water is added. The pH level of this detergent must be in accordance with the detergent manufacturer's recommendation.
- Remove oil and grease from the wash solution by using the oil skimmer.
- For oily or extremely soiled parts, it is recommended the oil skimmer be operated on a more frequent basis.
- Examine spray nozzles; clean and align if necessary (See **Cleaning and Aligning the Spray Nozzles**).
- Wipe down the exterior of the machine using spray degreaser and a soft, damp cloth. **TO PREVENT ELECTRICAL COMPONENT FAILURE, DO NOT SPRAY THE MACHINE WITH WATER.**

*NOTE: Degreaser spray and a damp cloth will usually remove all dirt and grime from the machine. For particularly stubborn soap deposits, use a soft cloth dampened with warm solution from the wash chamber.*

### Monthly Maintenance

- Drain and clean out the sump chamber (See **Cleaning out the Sump**).

### Cleaning and Aligning the Spray Nozzles

To ensure optimum cleaning performance, it is important that you examine the spray nozzles periodically and clean and align them if necessary.

To clean a plugged nozzle, remove it from the spray pipe and use a small wire brush to free the nozzle of any obstructions. When you replace the nozzle on the spray pipe, make sure you align it according to figure to maintain a proper spray pattern.

*NOTE: The spray nozzles are sized and positioned to optimize the distribution of cleaning solution in the wash chamber. If you remove the nozzles make sure you replace them in the correct position on the appropriate pipe. Spray nozzle specifications are stamped on the face of each nozzle, as shown.*

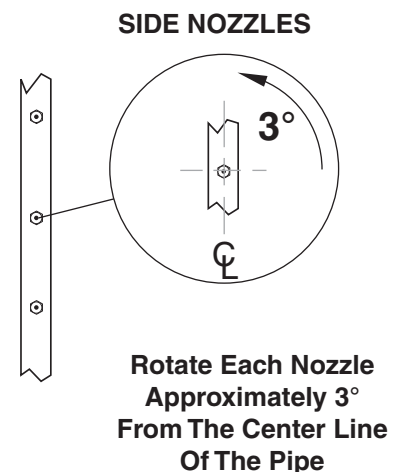
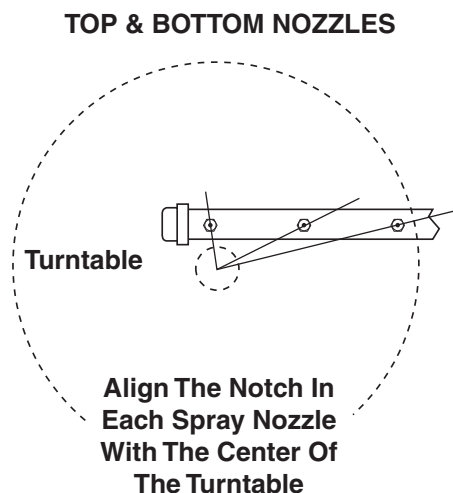

## Maintenance

### Cleaning out the Sump

1. Remove oil from the cleaning solution using the oil skimmer.
2. Remove the debris screen.
3. Drain the wash solution from the sump chamber. To drain the solution either use the sump drain or a small submersible pump.
4. Remove sand and other debris from the bottom of the sump chamber. To remove the debris either flush it out through the sump drain, or vacuum it out using a wet/dry vac. Dispose of the debris in accordance with applicable local, state, and federal regulations.

*NOTE: Take special care to ensure that the heating element and the low-water float are free of debris.*

A build up of debris around the heating element will decrease heating performance and may cause the element to overheat and fail. A build up of debris around the float may cause the low water shut-off system to malfunction (See **Low Water Shutoff System**)

5. Replace the debris screen.
6. Heat the wash water to operating temperature, then add appropriate amount of factory detergent.
7. Run the machine through a 15-minute wash cycle.

### Repairing The Machine

The following procedures outline the steps necessary to replace specific items on the machine that could wear out or otherwise fail.

#### Heating Element

##### Required Tools and Equipment

- 5/16" wrench or socket
- 1-1/2" socket and breaker bar
- sealing tape or compound
- medium phillips-head screwdriver

#### Replacement Procedure

1. Disconnect power to the machine.
2. Drain the wash solution from the sump.

3. Remove the rear panel from the machine (four screws; use a 5/16" wrench or socket).

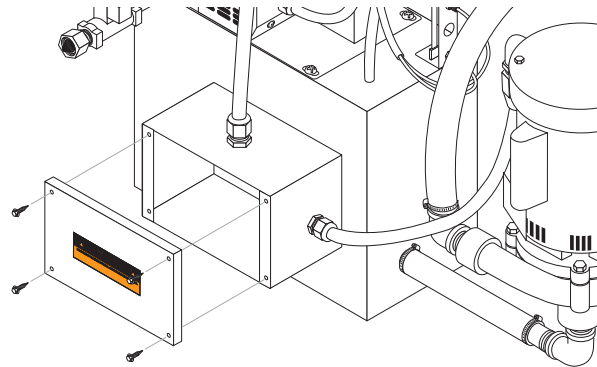

4. Detach the power leads from the heating element.

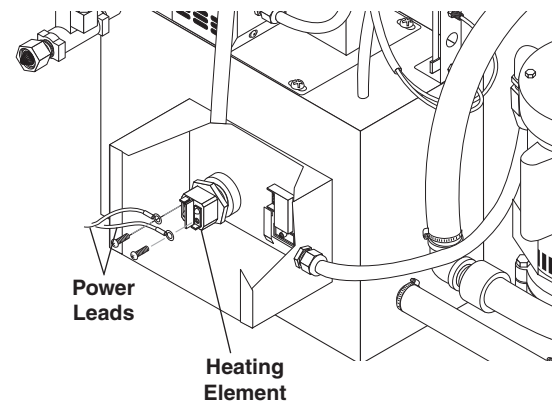

5. Using a 1-1/2" socket and breaker bar, unscrew the heating element from the machine.

*NOTE: Since the heating element is in continuous contact with the cleaning solution the threads may corrode slightly. The element may be difficult to remove. When you install a new heating element, use sealing tape or compound on the threads to deter corrosion, and be sure to install the rubber gasket to prevent leakage.*

6. Install the new heating element. Installation is the reverse of removal.

## Thermostat

### Required Tools and Equipment

- 5/16" wrench or socket
- medium phillips-head screwdriver
- large flat-head screwdriver

### Replacement Procedure

1. Disconnect power to the machine.
2. Remove the rear panel from the machine (ten screws; use a 5/16" wrench or socket).
3. Detach the power leads.
4. Using a large flat-head screwdriver, pry the thermostat out of the mounting bracket, then remove it from the machine.

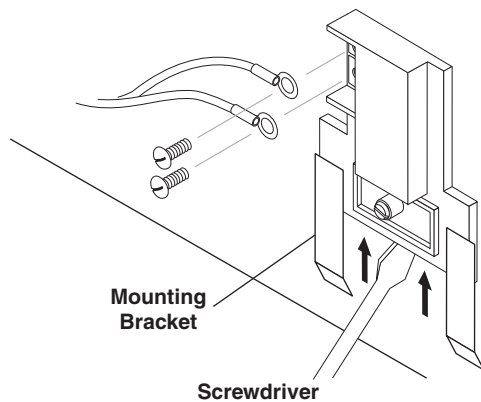

5. Install the new thermostat. Installation is the reverse of removal.

*NOTE: When you install the thermostat make sure you press it firmly into the mounting bracket. In order to operate correctly, the thermostat must be in direct contact with the rear wall of the sump chamber.*

## Timers and Switches on the Control Panel

### Required Tools and Equipment

- 5/16" wrench or socket
- 1/2" wrench or deep socket
- small phillips-head screwdriver
- small flat-head screwdriver

### Replacement Procedure

1. Disconnect power to the machine.
2. Close the lid.

3. Remove the lid cover (four screws use a 5/16" wrench or socket).

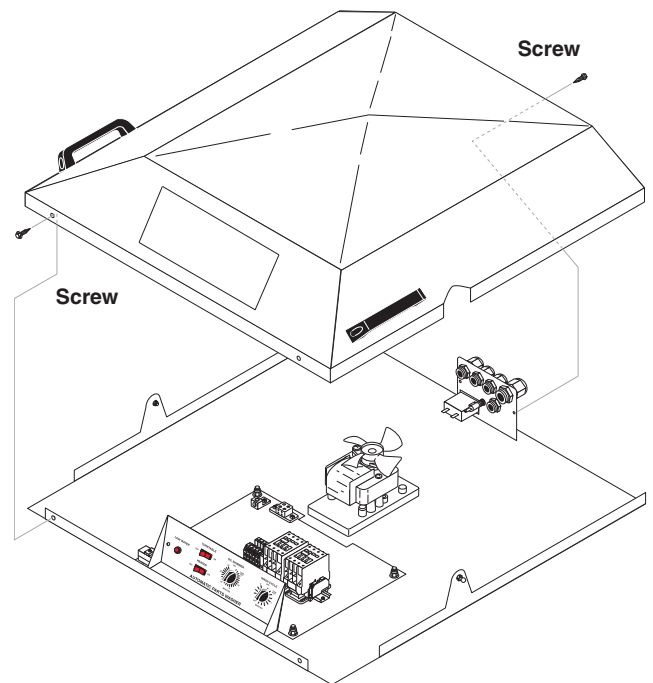

4. From the rear of the control panel, remove the power leads from the component you wish to replace, then remove the component.

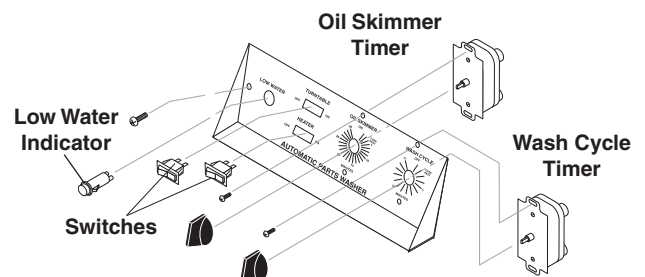

5. Replace the component, then reassemble the lid cover.
6. Ensure thermostat is set to 180°F.

## Maintenance

### Torque Limiter

The torque limiter prevents the turntable motor from burning out in case a part falls off the turntable and obstructs rotation. The torque limiter is pre-set at the factory, but you may need to adjust it if the turntable begins to slip or bind.

#### Adjusting the Torque Limiter

To adjust the torque limiter, perform the following procedure;

1. Raise the lid.
2. Loosen the torque limiter set screw (use a 1/8" allen wrench).

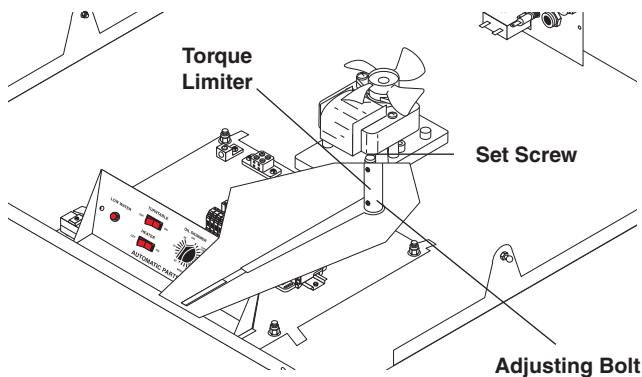

3. Rotate the torque arm 180°
4. Clamp the hub against the top spray arm with a pair of locking pliers, then use a spring scale on the end of the torque arm to measure the torque setting.

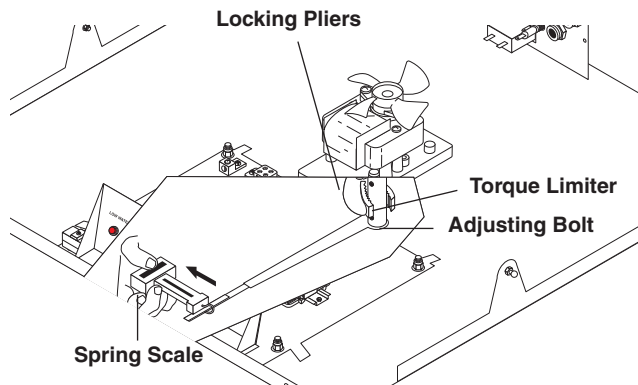

The torque arm should begin to slip at 7 pounds. If it slips at **less than 7** pounds, tighten the adjusting bolt. If it slips at **greater than 7** pounds, loosen the adjusting bolt.

5. Remove the locking pliers from the hub, then tighten the set screw.

### Turntable Motor

The turntable motor is located near the main electrical panel beneath the lid cover. To replace the turntable motor, perform the following procedure:

1. Disconnect power to the machine.
2. Close the lid.
3. Remove the lid cover (four screws use a 5/16" wrench or socket).

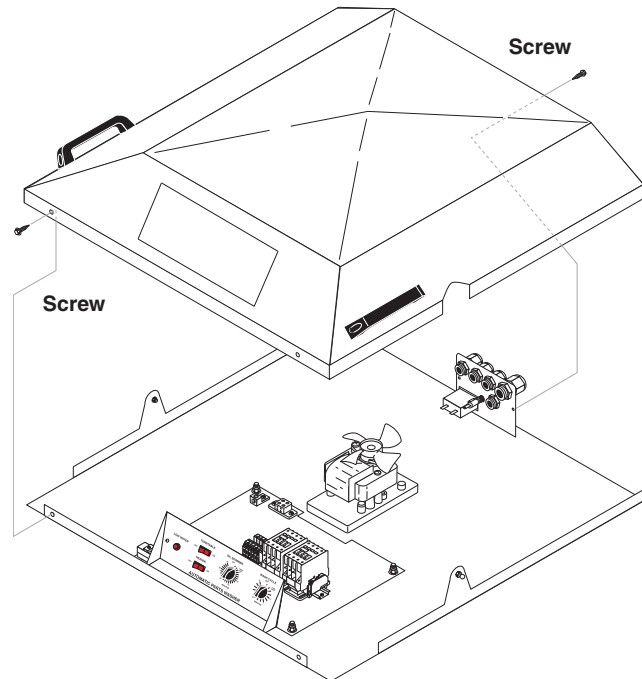

4. Raise the lid.

- Loosen the retaining screw to remove the torque arm assembly from the drive shaft (use a 1/8" allen wrench).

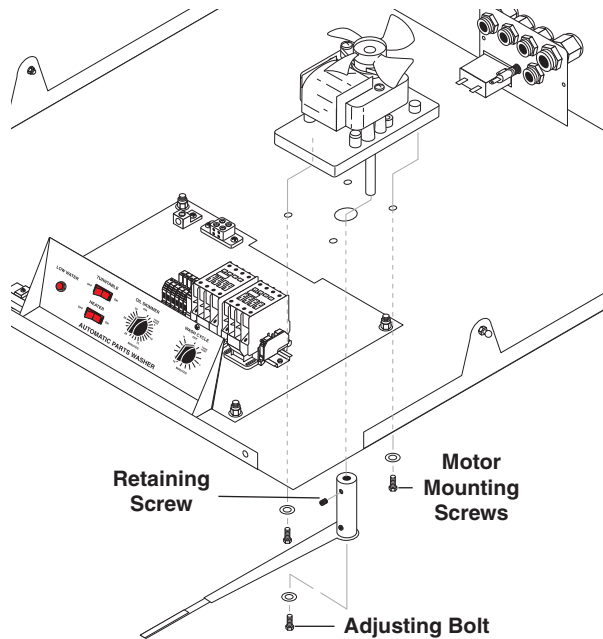

- Remove the four turntable mounting screws.
- Close the lid.
- Disconnect the power leads from the motor, then remove the motor from the lid.

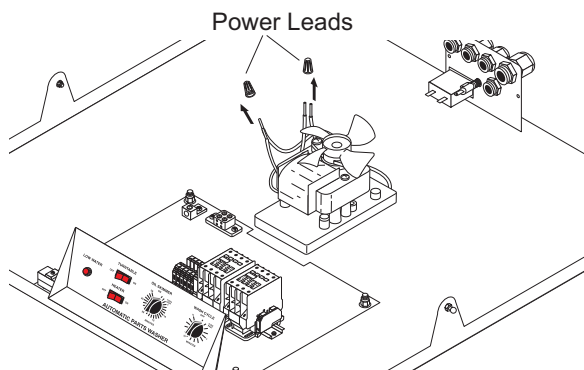

- Install the new motor. Installation is the reverse of removal.

## Using the Oil Skimmer System

The oil skimmer system is most effective if used when the cleaning solution in the sump is cool.

The frequency at which you must remove the oil from the wash solution will depend on machine usage. Under typical operating conditions you may need to remove the oil every day.

**IMPORTANT:** The skimmer motor is equipped with a thermal overload switch which protects the skimmer from overheating. If you attempt to use the oil skimmer system when the wash solution is hot, the thermal overload will probably trip and the motor will shut off until it cools. Under normal skimming conditions (when the wash solution is cool) the thermal overload should not trip.

To remove oil from the cleaning solution, perform the following procedure:

- Allow the machine to sit idle for at least 30 minutes to allow the oil to float to the surface of the wash solution.
- Ensure that the oil collection container is in place, then turn the skimmer timer to the "ON" position.

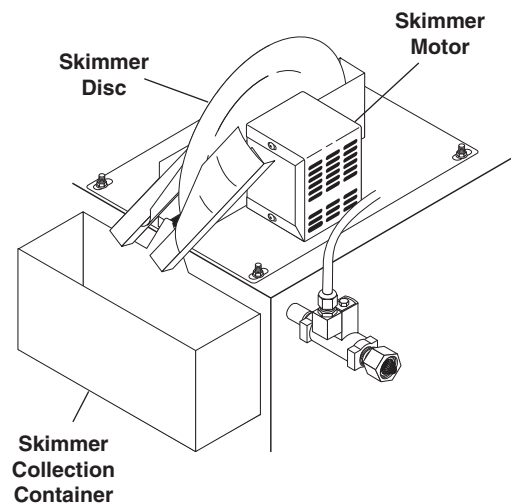

Allow the oil skimmer to operate until it is no longer extracting oil from the cleaning solution.

**Tip:** While extracting oil from the cleaning solution, oil will flow off the wiper blades in a fine continuous stream. Water will flow off the blades in droplets. Once droplets begin to flow off the wiper blades, stop the skimmer motor.

- Dispose of the oil in the collection container in accordance with local and state regulations, then replace the container.

## Troubleshooting

### Troubleshooting the Electrical System

To troubleshoot the electrical system use the following diagrams to eliminate the possibility of a blown fuse or a bad connection, then refer to Testing Individual Components to determine which component is causing the problem.



**WARNING: Keep water away from electric wiring or fatal electric shock may result**

- Electrical troubleshooting should be performed by qualified personnel only.
- Avoid contact with power leads, terminals, and fuses when power is connected.
- Disconnect power to machine before removing fuses or other electrical components.

### Troubleshooting the Electrical Panel

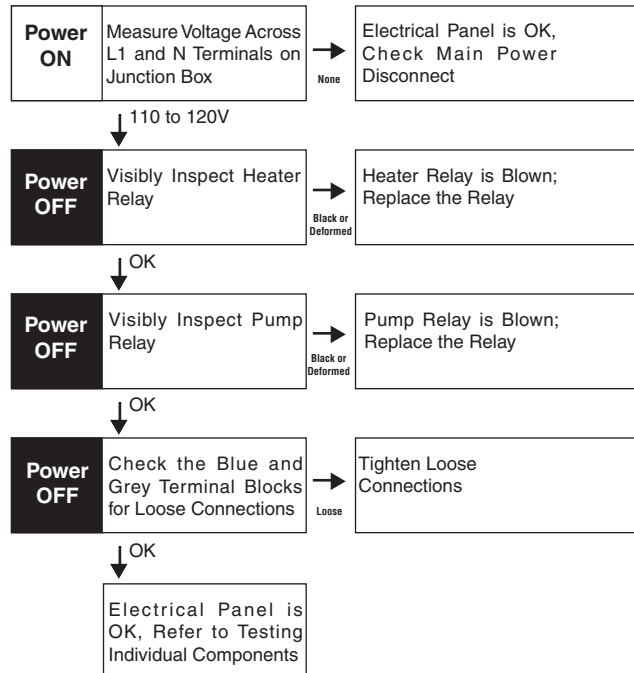
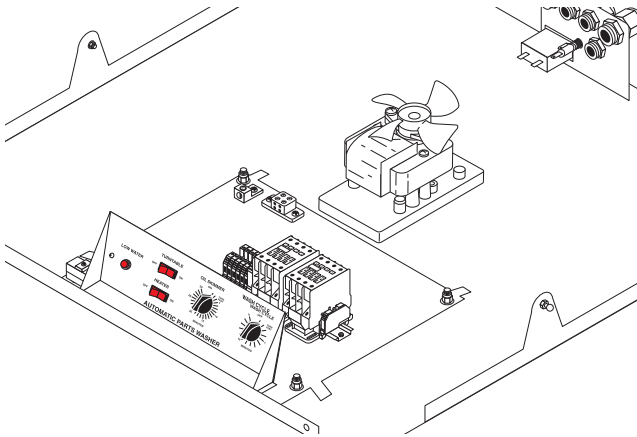

## Testing Individual Components

*NOTE: The following troubleshooting procedures require the use of a volt/ohm meter. If you are not familiar with using a volt/ohm meter do not attempt to perform the following troubleshooting procedures. If you need assistance please contact your dealer.*

### Wash Cycle Timers

1. Disconnect power to the machine.
2. Disconnect all wires and remove the timer from the control panel and (See **Timers and Switches on the Control Panel**).

3. With the timer in the **OFF** position, test for continuity using an ohm meter.

If there **is** continuity the timer is no longer functional; replace the timer.

4. With the timer in the **ON** position, test for continuity using an ohm meter.

If there **is not** continuity the timer is no longer functional; replace the timer.

### Heating Element

1. Disconnect power to the machine.
2. Remove the rear panel from the machine (four screws; use a 5/16" wrench or socket).

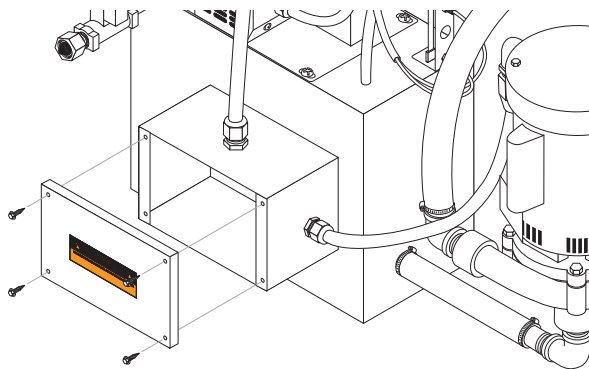

3. Detach the power leads from the heating element.

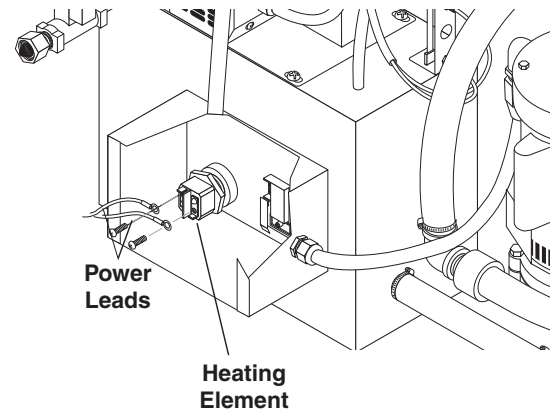

4. Use an ohm meter to measure the resistance of the heating element. The resistance should be approximately 10 Ohms if not, replace the heating element (See **Heating Element**).

### Thermostat

1. Disconnect power to the machine.
2. Remove the rear panel from the machine (ten screws; use a 5/16" wrench or socket).
3. Detach the power leads from the thermostat.
4. Using a large flat-head screwdriver, pry the thermostat out of the mounting bracket, then remove it from the machine.

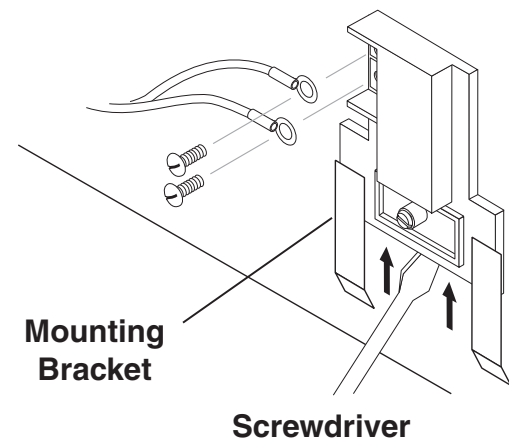

5. Set the thermostat to 120°F, warm it to just above 120°F, then test for continuity.

If there **is** continuity the thermostat is no longer functional; replace the thermostat.

6. Allow the thermostat to cool to room temperature, then test for continuity.

If there **is not** continuity the thermostat is no longer functional; replace the thermostat.

## Maintenance

PROBLEM	POSSIBLE CAUSE	SOLUTION
<b>POOR CLEANING PERFORMANCE</b>	Turntable switch is OFF	Verify that the turntable switch is <b>ON</b> (See <b>Turntable Switch</b> ).
	Parts are obstructing each other	Check the position of parts on turntable; position parts to allow flow of cleaning solution around and between them.
	Low water level in sump	Check sump water level; add water if necessary.
	Clogged or improperly aligned spray nozzles	Check spray nozzles for obstructions and alignment; clean and align if necessary (See <b>Cleaning and Aligning the Spray Nozzles</b> ).
	Low detergent concentration 10-11 pH	Add 1-2 scoops of detergent and observe cleaning performance; add 1-2 scoops more if necessary. Measure pH.
	Wash solution is not properly heated	See <i>wash solution is not heating</i>
	Pump is not operating properly	See <i>pump does not operate properly</i> .
<b>WASH SOLUTION NOT HEATING</b>	Blown fuse	Refer to <b>Troubleshooting the Electrical System</b> .
	Low water level in sump	Check the water level in the sump; add water if necessary (See <b>Low Water Shut-Off</b> ).
	Thermostat is incorrectly set	Check thermostat setting; set to 180° (See <b>Adjusting the Thermostat</b> ).
	Excess debris is built up around heating element	Check for debris buildup around heating element; clean out if necessary (See <b>Cleaning out the Sump</b> ).
	Line voltage is too low	Contact a licensed electrician to verify that the incoming line voltage meets requirements.
	Failed heater timer	Test the heater timer; replace if necessary (See <b>Wash Cycle and Heater Timers</b> ).
	Failed thermostat	Test the thermostat; replace if necessary (See <b>Thermostat</b> )
	Failed heating element	Test the heating element; replace if necessary (See <b>Heating Element</b> )
<b>FOAMING</b>	Machine operating with cold water	Bring water up to correct temperature
	Grease, high detergent motor oils, transmission oil, gear lubes	Do not place oil pan or transmission pan into machine without pouring oil out of it.
	Not enough detergent	Add more detergent, check pH level. Use de-foamer.
<b>WHITE POWDER ON PARTS</b>	Solution is old	Change sump water and recharge with fresh detergent and vapor corrosion inhibitor.
	Water hardness and TDS (totally dissolved solids)	Use a water softener and/or change your sump water more frequently.
	Large parts can dry before solutions runs off, leaving powdery residue	Turn heat down to approximately 140°.



<b>PROBLEM</b>	<b>POSSIBLE CAUSE</b>	<b>SOLUTION</b>
<b>MACHINE FAILS TO START WHEN "WASHING PARTS" PROCEDURE IS FOLLOWED</b>	Main power disconnect is off	Verify that no service is being performed on the machine, then turn the main power disconnect on.
	Door is not closing properly	Check the lid latch and lid safety switch; adjust if necessary (See Adjusting the Safety Switch).
	Failed lid safety switch	Test the door closure safety switch; replace if necessary (See Lid Safety Switch).
	Failed washer cycle timer	Test the wash cycle timer; replace if necessary (See Wash Cycle, Heater and Skimmer Timers).
	Pump is not operating properly	See pump does not operate properly section.
<b>TURNTABLE DOES NOT OPERATE PROPERLY</b>	Turntable switch is OFF	Ensure that the turntable switch is in the on position (See Turntable Switch).
	Parts are obstructing turntable rotation	Check for parts obstructing rotation of the turntable; rearrange if necessary.
	Worn thrust bearing	Inspect the thrust bearing; replace if necessary
	Torque limiter improperly set	Verify the setting on the torque limiter; adjust if necessary
	Failed wash cycle timer	Test the wash cycle timer; replace if necessary (See Wash Cycle, Heater, and Skimmer Timers).
	Failed start capacitor	Test the start capacitor; replace if necessary (See Start Capacitor).
	Failed turntable motor	Contact a licensed electrician to test the motor; replace if necessary (See Turntable Motor).
<b>PUMP DOES NOT OPERATE PROPERLY</b>	Low water level in sump	Check the water level in the sump; add water if necessary (See Low Water Shut-Off System).
	Pump intake is plugged	Check pump intake for obstructions; clean out if necessary.
	Pump overload relay is tripped	Reset the motor overload relay.
	Blown fuse	Check electrical panel for a blown fuse; replace if necessary.
	Line voltage is too low	Contact a licensed electrician to verify that the incoming line voltage meets requirements as specified on the machine ID tag.
	Pump is failed	Contact a licensed electrician to test the pump; replace if necessary.
<b>MACHINE RUSTING INTERIOR</b>	Steam condensing on inside of a lid	Leave lid open during idle periods. Check soap concentration.



# Parts

## Automatic Aqueous Parts Washer

<b>1.043-540.0</b>	<b>H2O-2412 115V</b>
<b>1.043-541.0</b>	<b>H2O-2412 208V</b>
<b>1.043-542.0</b>	<b>H2O-2412 230V</b>
<b>1.043-543.0</b>	<b>H2O-2412 115V SS</b>
<b>1.043-544.0</b>	<b>H2O-2412 208V SS</b>
<b>1.043-545.0</b>	<b>H2O-2412 230V SS</b>
<b>1.043-546.0</b>	<b>H2O-2412 208V 2HP</b>
<b>1.043-547.0</b>	<b>H2O-2412 230V 2HP</b>
<b>1.043-548.0</b>	<b>H2O-2412 208V 2HP SS</b>
<b>1.043-549.0</b>	<b>H2O-2412 230V 2 HP SS</b>

# 2412 Front

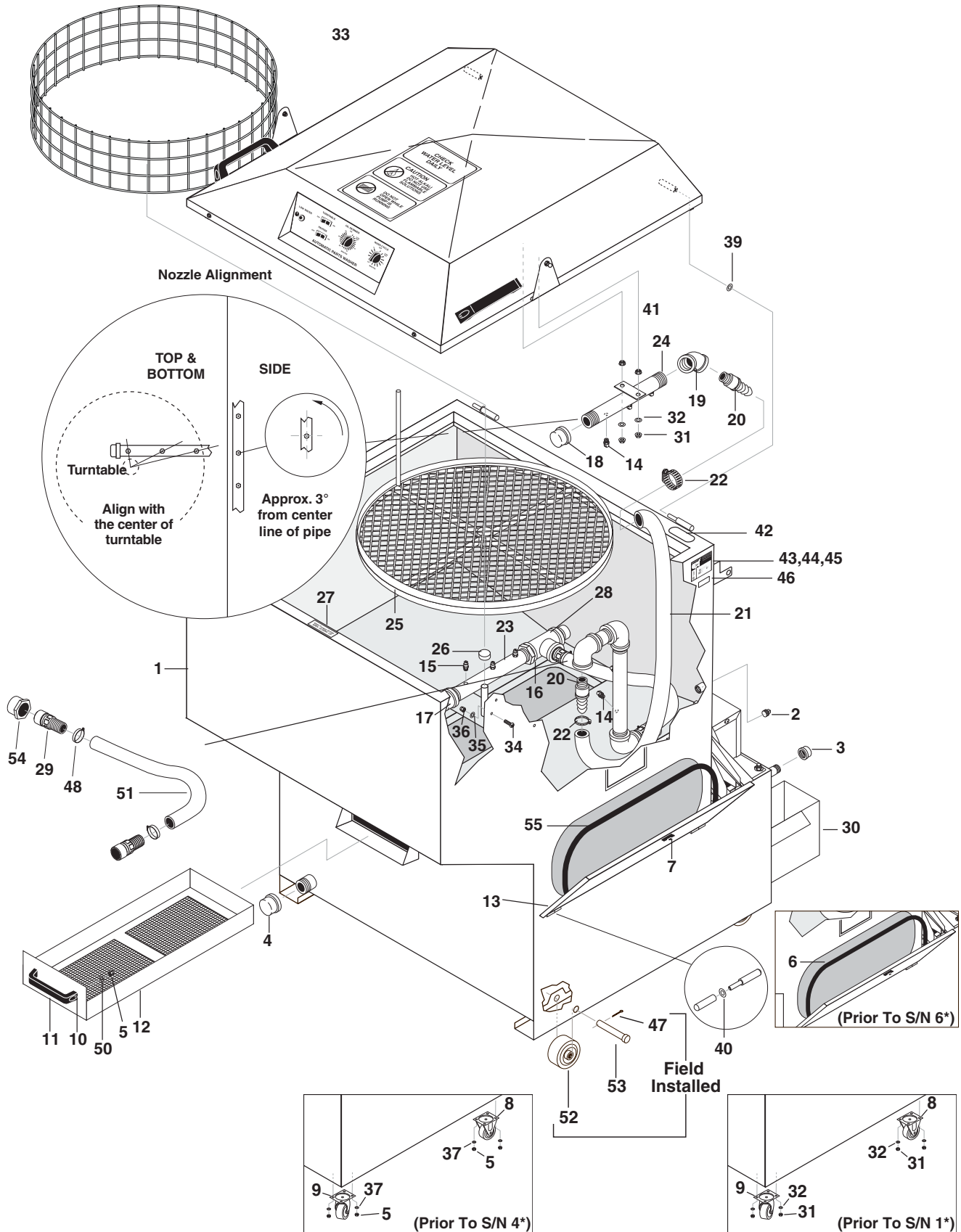

REF	PART NO.	QTY	DESCRIPTION	SERIAL NO. FROM	NOTES
1	8.913-719.0	1	TANK ASSY 2412		
-	8.922-996.0	1	WLMT, TANK, SS		
2	8.706-328.0	1	PIPE, PLUG 1/4" GALV.		
-	8.753-897.0	1	PLUG, PIPE, 1/4, 304 SS		
3	8.706-350.0	1	PIPE, CAP 1/2" GALV.		
-	8.753-615.0	1	CAP, 1/2" THREADED, 304 SS		
4	8.706-349.0	1	PIPE, CAP 1-1/2" GALV.		
-	8.749-821.0	1	PIPE-CAP 1-1/2" STAINLESS STEEL		
5	8.627-083.0	18	NUT, 5/16-18 HEX NYLOCK SS	1*	
6	8.915-388.0	48"	SEAL, BULB TYPE (12G) NITRILE, SIDE PROFILE		
7	9.804-185.0	1	LATCH-VISE ACTION SIDE ACC COVER		
8	8.711-919.0	2	CASTER, FIXED, 2-1/2" POLYWHEEL		
9	8.711-920.0	2	CASTER, SWIVEL, 2-1/2" X 1-1/8" POLYOLEFIN		
10	8.627-721.0	2	SCREW, 5/16-18 X 1 SCHCS SS		
11	9.804-203.0	1	HANDLE, DOOR/STRAINER		
12	8.913-705.0	1	DEBRIS, TRAY ASSY		
-	8.922-354.0	1	WLMT, DEBRIS TRAY, SS		
13	8.922-512.0	1	WLMT, DOOR, SUMP ACCESS, SS		
14	8.712-777.0	5	NOZZLE, 50°, #3		
-	9.804-196.0	5	NOZZLE, 50°, #3 STAINLESS		
-	8.712-775.0	5	NOZZLE -50 DEG. #4 STEEL		2HP
-	9.804-424.0	5	NOZZLE -50 DEG. #4 STAINLESS		2HP SS
15	8.755-292.0	3	NOZZLE, 80°, #3		
-	8.714-202.0	3	NOZZLE, 80°, #3, SS		
-	8.712-870.0	3	NOZZLE -95 DEG. #4 STEEL		2HP
-	8.642-777.0	3	NOZZLE -95 DEG. #4, SS		2HP SS
16	8.706-047.0	1	PIPE, BUSHING 1-1/4" TO 1" BLACK		
-	8.706-288.0	1	BUSHING 1' X 1/1/4' STAINLESS		
17	8.706-081.0	1	CAP, PIPE 1 NPT 150WP NON PL		
-	8.753-614.0	1	CAP, 1" THREADED, 304 SS		
18	8.706-320.0	1	CAP, 3/4" BLACK PIPE		
-	8.749-619.0	1	PIPE CAP 3/4" STAINLESS		
19	8.706-188.0	1	ELBOW, 45°, 3/4" BLACK		
-	8.754-347.0	1	ELBOW, 45°, 3/4" NPT SS		
20	8.706-340.0	2	PIPE, BARBED, MALE NPT 3/4" BLACK		
-	9.804-210.0	2	PIPE, BARBED, MALE NPT 3/4" STAINLESS		
21	9.802-261.0	24"	HOSE, 3/4" PUSH-ON, PER/FT		
22	8.623-311.0	2	CLAMP, 1.0" WORM GEAR		
23	8.720-002.0	1	SPRAY PIPE 1" X 10"		
-	8.923-239.0	1	SPRAY PIPE 1" X 10", SS		
24	8.913-706.0	1	ASSY., UPPER SPRAY BAR		
-	8.923-020.0	1	WLMT, UPPER SPRAY BAR, SS		

**2412 Front**

REF	PART NO.	QTY	DESCRIPTION	SERIAL NO. FROM	NOTES
25	8.913-724.0	1	TURNTABLE ASSY		
-	8.923-014.0	1	WLMT, TURNTABLE, SS		
26	9.804-259.0	1	THRUST BEARING		
27	8.642-382.0	1	DECAL, KEEP HANDS CLEAR WHEN CLOSING LID		
28	8.706-217.0	1	TEE, 1-1/4" X 1-1/4" X 1" BLACK PIPE		
-	8.754-351.0	1	TEE 1-1/4" X 1-1/4" X 1-1/4" SS		
29	8.730-404.0	2	PIPE-BARBED/MALE NPT 1' GALV		
-	8.753-900.0	2	PIPE-BARBED/MALE NPT 1" 316 SS		
30	8.924-172.0	1	BUCKET, OIL		
31	8.600-581.0	2	NUT, 1/4-20 HEX NYLOCK SS		
32	8.636-177.0	2	WASHER, 1/4 FLT SS		
33	8.705-962.0	1	RING, CONTAINMENT 24"		
34	8.627-929.0	3	WASHER,#10 FLAT W/NEOPRENE		
35	8.627-961.0	3	WASHER, 1/4 SEG SS		
36	8.627-099.0	3	NUT, 10-32 HEX NYLOCK SS		
37	8.601-067.0	16	WASHER, 5/16 FLT SS	1*	
38	8.731-254.0	1	PARTS BASKET, SMALL 8 X 8 X 4		NOT SHOWN
39	8.725-296.0	2	WASHER, BULLET HINGE 8MM PIN BRASS		
40	8.642-534.0	2	WELD HNG, BUSH, M6, SS		
41	8.627-137.0	2	NUT, 1/4-20 SERFLG STL ZNPLT		
42	8.751-325.0	1	FILTER MEDIA, 2" X 12" X 1"		
43	8.642-387.0	1	LABEL, ASSEMBLED USA		
44	8.642-392.0	1	LABEL, CLEAR LEXAN		
45	N/A	1	LABEL, UL/ETL		
46	8.642-406.0	1	LABEL, PATENT NUMBER		
47	8.712-875.0	4	PIN -COTTER 1/8' X 1 1/4'	4*	FIELD INSTALLED
48	8.623-330.0	2	CLAMP, 1.25" WORM GEAR SS		
49	8.642-580.0	1	HOSE, HIGH FLEX, 1"	3*	
50	8.627-965.0	2	WASHER, 5/16 SEG SS		
51	8.642-818.0	1	HOSE, 1" ID X 11-1/4"	3*	
52	8.713-037.0	4	WHEEL -POLYOLEFIN 4' X 2' X 3/4'BOR	4*	FIELD INSTALLED
53	8.712-939.0	4	PIN -CLEVIS 3/4' X 3 1/2'	4*	FIELD INSTALLED
54	8.706-288.0	1	BUSHING 1" X 1-1/4" STAINLESS		SS ONLY
55	8.915-388.0	43.25	SEAL, BLB TYPE EPDM 12G THICK SD PRFILE	6*	

\*SEE SERIAL NUMBER PAGE FOR REFERENCE



# 2412 Rear

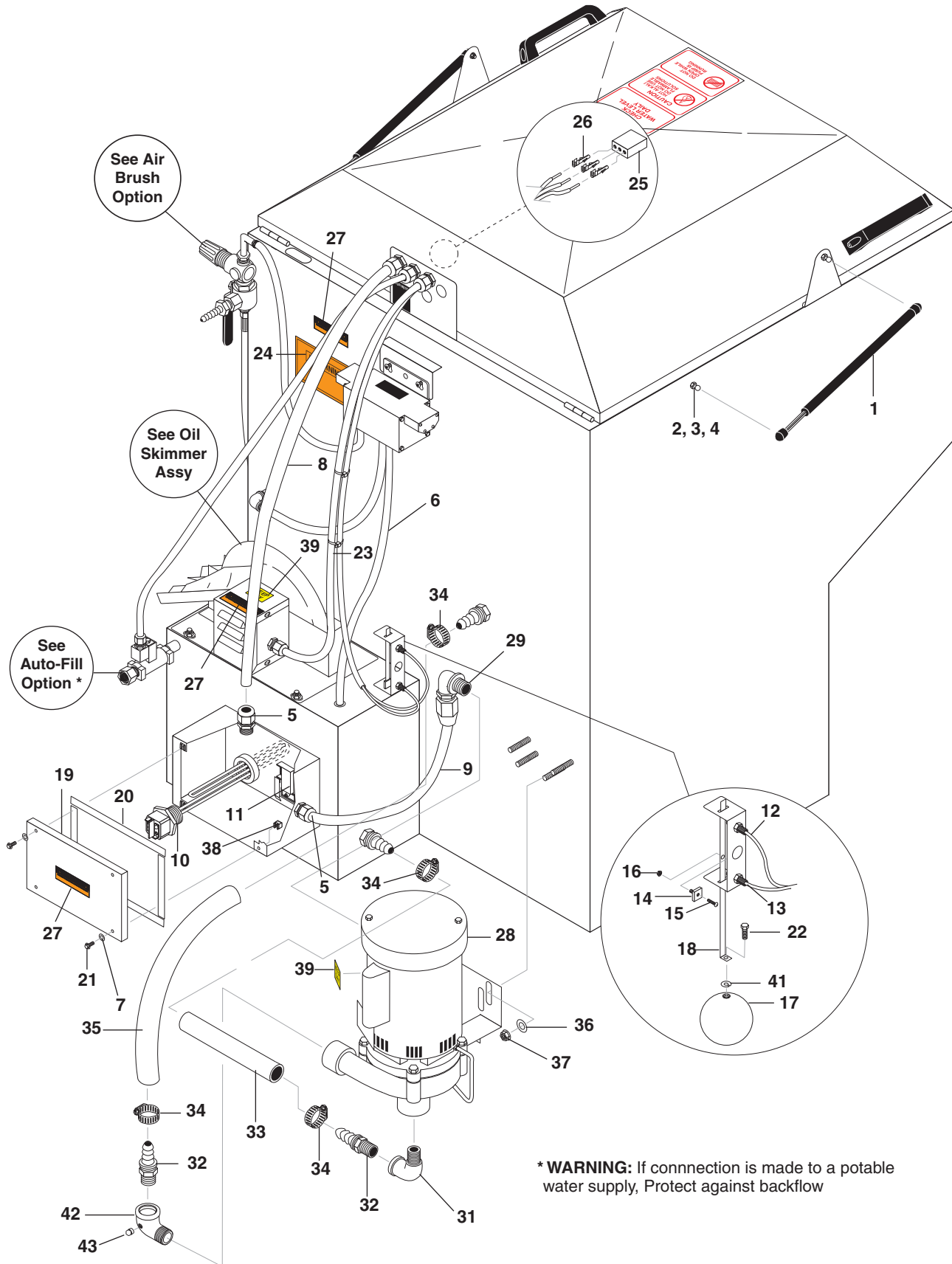

**\* WARNING:** If connection is made to a potable water supply, Protect against backflow



REF	PART NO.	QTY	DESCRIPTION	SERIAL NO. FROM	NOTES
1	8.714-540.0	2	GAS SPRING, STRUT 70# (4514QF)		(115V)
-	8.724-076.0	2	GAS SPRING 90# (7227SA)		(208V, 230V)
2	9.804-207.0	2	BALL STUD, 5/16"-18 UNC 10MM 2A STUD		
3	8.627-083.0	2	NUT, 5/16-18 HEX NYLOCK SS		
4	8.627-965.0	2	WASHER, 5/16 SEG SS		
5	8.716-547.0	2	CONNECTOR, 1/2" L/T STRAIGHT, BLACK		
6	8.716-011.0	39"	CONDUIT, FLEXO 1/2" BLK		
7	8.636-177.0	4	WASHER, 1/4 FLT SS		
8	9.802-448.0	36"	CONDUIT, WATER TIGHT, FLEX 1/2"		
9	9.802-448.0	22"	CONDUIT, WATER TIGHT FLEX 1/2"		
10	8.714-187.0	1	HEATING ELEMENT,.8KW/120V/1 PH1" NPT, MS 9"L W/SEAL		(115V 1 PH)
-	8.712-813.0	1	HEATING ELEMENT, 4.5 KW/230V/1 PH, 1" NPT MS W/SEAL		(208V 1 PH, 230V 1 PH)
11	8.713-593.0	1	THERMOSTAT, SNAP DISC 180° F 1 PH		
12	9.804-119.0	1	SWITCH, MAGNETIC REED SENSOR NC		
13	9.804-118.0	1	SWITCH, MAGNETIC REED SENSOR, NO		
14	9.804-120.0	1	MAGNET, REED SENSOR TARGET		
15	8.642-545.0	1	SCREW, #4-40 X .5 PHRDHMS SS		
16	8.627-128.0	1	NUT, 4-40 HEXSTRW STL ZNPLT		
17	8.754-718.0	1	FLOAT, 2.5 IN, S/S W/ .25 INT THR		5*
18	8.922-155.0	1	FLOAT ROD SS		
19	8.921-961.0	1	COVER, HEATER ELEMENT		
20	8.643-499.0	1	SEAL HEATER BOX TOP LOAD		
21	8.627-378.0	4	SCREW, 1/4-20 X .75 HHCS SS NP		
22	8.627-411.0	1	SCREW, 1/4-20 X .5 SCHCS SS		
23	9.802-423.0	60"	CORD 16/3		
24	8.642-400.0	1	DECAL, WARNING		
25	8.713-656.0	1	CONNECTOR, ELECTRICAL, 3 PIN FEMALE		
26	8.713-768.0	3	CONNECTOR, ELECTRICAL PIN MALE		
27	8.642-388.0	3	LABEL, DISCONNECT POWER SUPPLY		
28	8.715-398.0	1	PUMP SCOT, 1/2 HP 115/230V 1 PH		
-	8.713-359.0	-	SEAL KIT		
-	8.713-360.0	-	O-RING		
-	8.751-253.0	1	PUMP, SCOT 2HP, 1PH, ODP SEAL FLUSH DRP		2HP
29	9.802-517.0	1	CONNECTOR, 1/2 L/T, 90°, BLACK		
30	9.802-105.0	1	PLUG, 7/8" HOLE		NOT SHOWN

**2412 Rear**

REF	PART NO.	QTY	DESCRIPTION	SERIAL NO. FROM	NOTES
31	8.706-199.0	1	ELBOW, 1-1/4", 90 DEG, STREET, GALV	2*	
-	8.754-076.0	1	ELBOW, 1-1/4", 90° STREET, S/S	2*	
32	8.706-341.0	2	PIPE, BARBED MALE NPT 1-1/4" GALV.		
-	9.804-198.0	2	PIPE, BARBED MALE NPT 1-1/4" STAINLESS		
33	8.714-828.0	1	HOSE, 1-1/4" X 6-1/2" PRECUT BLACK 200 PSI		
34	8.617-725.0	4	CLMP,HOS#24 1-1/16MIN 2		
35	9.804-244.0	1	PIECE OF TUBE 1 1/4"X370MM, 14BAR		
36	8.627-891.0	4	WASHER, 3/8 SS		
37	8.627-193.0	4	NUT HEX NYL LOC 3/8-16		
38	9.802-793.0	4	NUT, CAGE 1-4" X 16 GA		
39	8.642-408.0	2	DECAL, KEEP DRY		
40	8.712-896.0	1	SCOOP, DETERGENT, WHITE 16 OZ.		NOT SHOWN
41	8.921-274.0	1	SPACER, BRAKE LINK, 800		
42	8.642-786.0	1	ELBOW, 1-1/4" STREET W/ TAP, GALV	2*	
-	8.642-787.0	1	ELBOW, 1-1/4" STREET W/ TAP, SS	2*	
43	8.706-328.0	1	PIPE PLUG 1/4, GALV	2*	
-	8.753-897.0	1	PLUG, PIPE, 1/4, 304SS	2*	
44	8.643-498.0	1	PAD FLOAT MAGNET		



# Auto Fill, Detail Brush & Power Brush Options

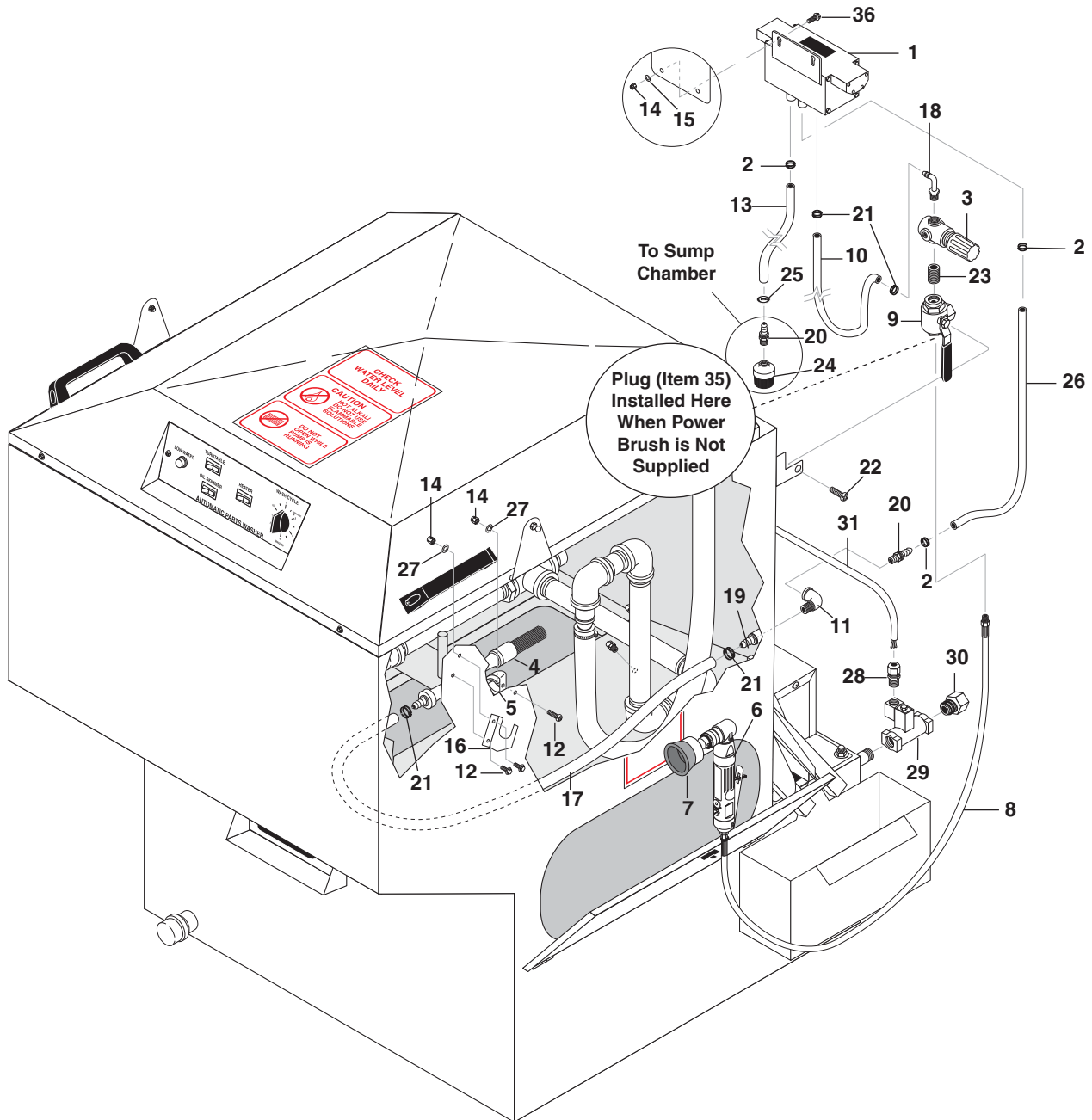

## Auto Fill, Detail Brush & Power Brush Options

REF	PART NO.	QTY	DESCRIPTION	SERIAL NO. FROM	NOTES
<b>DETAIL &amp; POWER BRUSH KIT (8.725-245.0)</b>					
1	8.712-778.0	1	PUMP -AIR DIAPHRAGM		
2	8.623-315.0	3	CLAMP, 3/8 HOSE (D-SLOT)		
3	8.712-810.0	1	REGULATOR -AIR 1/4" NPT		
4	9.804-091.0	1	BRUSH -POLYFLOW (FLO-THRU)		
5	8.712-815.0	1	CLIP -DETAIL BRUSH		
6	8.712-834.0	1	DRILL -PNEUMATIC AIR R-ANGLE		
7	8.712-835.0	1	BRUSH -WIRE CUP 2-3/4" DIA., 1/4" STEM		
8	8.712-836.0	1	HOSE -ASSEMBLY 1/4" X 60", MPT EA END POWER BRUSH		
9	8.712-838.0	1	PIPE -BALL VALVE 1/4" 3-WAY		
10	9.802-254.0	24"	HOSE, 1/4", PUSH-ON, FUEL LINE /FT		
11	8.706-161.0	1	ELBOW, 1/4", STREET, 90° GALV		
12	8.627-547.0	3	SCREW, 10-32 X .625 PHPNHMS SS		
13	8.711-785.0	27.5"	HOSE, 3/8" PUSH ON, /FT		
14	8.627-099.0	5	NUT, 10-32 HEX NYLOCK SS		
15	8.601-065.0	2	WASHER, .203 X .562 X .032 FLT		
16	8.915-637.0	1	BRACKET, POWER BRUSH		
17	8.714-007.0	40"	HOSE -1/4" ID X 7/16" OD BUNA TUBING 60 DURO		
18	8.624-036.0	1	HOSEBARB, 1/4MPT X 1/4 9D DL		
19	8.619-750.0	1	HOSEBARB, 1/4MPT X 1/4 DL		
20	8.619-755.0	2	HOSEBARB 1/4MPT X 3/8 DL		
21	8.623-309.0	4	CLAMP, 1/4 ID HOSE		
22	8.714-255.0	2	SCREW-10-24 X 1/4"SS MS PHIL		
23	8.600-559.0	1	NIPPLE 1/4 CLOSE		
24	8.712-808.0	1	FILTER -INLET (MESH BALL 1/4" NPT20 X 20 MESH) DETAIL PUMP		
25	9.802-103.0	1	BUSHING, SNAP, 5/8"		
26	8.711-785.0	24"	HOSE, 3/8" PUSH-ON, /FT		
27	8.627-961.0	3	WASHER, 1/4 SEG SS		
36	8.642-541.0	2	SCREW, #10-32 X .5 HHSEFLGMS SS		
<b>DETAIL BRUSH KIT (8.725-251.0)</b>					
1	8.712-778.0	1	PUMP -AIR DIAPHRAGM		
2	8.623-315.0	3	CLAMP, 3/8 HOSE (D-SLOT)		
3	8.712-810.0	1	REGULATOR -AIR 1/4" NPT		
4	9.804-091.0	1	BRUSH -POLYFLOW (FLO-THRU)		
5	8.712-815.0	1	CLIP -DETAIL BRUSH		
9	8.712-838.0	1	PIPE -BALL VALVE 1/4" 3-WAY		
10	9.802-254.0	24"	HOSE, 1/4", PUSH-ON, FUEL LINE/FT		
11	8.706-161.0	1	ELBOW, 1/4", STREET, 90° GALV		

## **Auto Fill, Detail Brush & Power Brush Options**

REF	PART NO.	QTY	DESCRIPTION	SERIAL NO. FROM	NOTES
12	8.627-547.0	3	SCREW, 10-32 X .625 PHPNHMS SS		
13	8.711-785.0	27.5"	HOSE, 3/8" PUSH ON, /FT		
14	9.804-567.0	5	NUT, 10/32", ESNA		
15	8.718-959.0	2	WASHER, #10 FLAT S/S		
17	8.714-007.0	40"	HOSE -1/4" ID X 7/16" OD BUNA TUBING 60 DURO		
18	8.624-036.0	1	HOSEBARB, 1/4MPT X 1/4 9D DL		
19	8.619-750.0	1	HOSEBARB, 1/4MPT X 1/4 DL		
20	8.619-755.0	2	HOSEBARB 1/4MPT X 3/8 DL		
21	8.623-309.0	4	CLAMP, 1/4 ID HOSE		
22	8.714-255.0	2	SCREW-10-24 X 1/4"SS MS PHIL		
23	8.600-559.0	1	NIPPLE 1/4 CLOSE		
24	8.712-808.0	1	FILTER -INLET (MESH BALL 1/4" NPT 20 X 20 MESH) DETAIL PUMP		
25	9.802-103.0	1	BUSHING, SNAP, 5/8"		
26	8.711-785.0	24"	HOSE, 3/8" PUSH-ON, /FT		
27	8.718-568.0	3	WASHER, 1/4" FLAT SS SEALING RUB		
35	8.706-328.0	1	PLUG, PIPE 1/4" NPT GALV.		
36	8.718-810.0	2	SCREW, 10/32" X 1/2" WHIZ LOC FLANGE		
<b>POWER BRUSH OPTION (8.725-258.0)</b>					
6	8.712-834.0	1	DRILL -PNEUMATIC AIR R-ANGLE		
7	8.712-835.0	1	BRUSH -WIRE CUP 2-3/4" DIA., 1/4" STEM		
12	8.642-541.0	3	SCREW, #10-32 X .5 HHSEFLGMS SS		
14	8.627-099.0	3	NUT, 10-32 HEX NYLOCK SS		
16	8.915-637.0	1	BRACKET, POWER BRUSH		
27	8.627-961.0	3	WASHER, 1/4 SEG SS		
<b>AUTOFILL OPTION (8.725-261.0)</b>					
28	9.802-514.0	2	STRAIN RELIEF, STRT, LQ TITE 3231 SMALL		
29	8.713-149.0	1	SOLENOID VALVE, 1/2" BRASS		
30	9.802-146.0	1	SWIVEL, 1/2" MP X 3/4" GHF W/STRAINER		
31	9.802-423.0	48"	CORD, SERVICE, SEO, 16/3, /FT COLEMAN		
32	8.713-768.0	3	S CONNECTOR, ELECTRICAL PIN MALE		NOT SHOWN
33	8.713-656.0	1	S CONNECTOR, ELECTRICAL 3 PIN FEMALE		NOT SHOWN



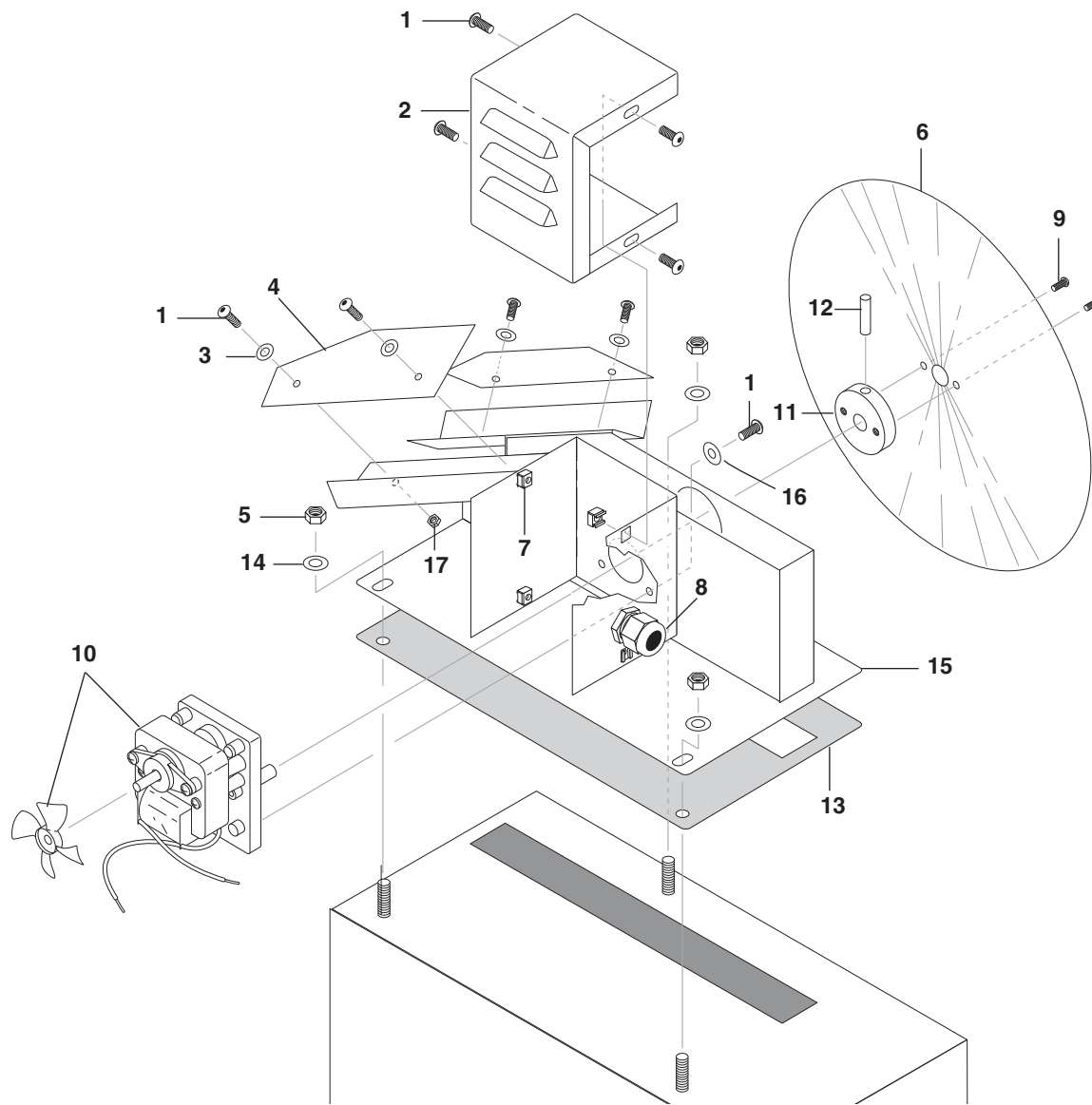



REF	PART NO.	QTY	DESCRIPTION	SERIAL NO. FROM	NOTES
1	8.642-541.0	11	SCREW, #10-32 X .5 HHSERFLGMS SS		
2	8.913-733.0	1	COVER, MOTOR, DISC SKIMMER SS		
3	8.601-065.0	4	WASHER, .203 X .562 X .032 FLT		
4	9.804-102.0	2	BLADE, WIPER, DISC SKIMMER SS		
5	8.600-581.0	3	NUT, 1/4-20 HEX NYLOCK SS		
6	8.918-672.0	1	DISC, SKIMMER SS		
7	9.802-791.0	4	NUT, CAGE, 10/32" X 16 GA.		
8	9.802-514.0	1	STRAIN RELIEF, STRT, LQ TITE		
9	8.642-540.0	2	SCREW, #6-32 X .5 PHRDHMS SS		
10	8.904-676.0	1	MOTOR, DISC SKIMMER		
11	8.719-987.0	1	HUB, DISC MOUNT, DISC SKIMMER		
12	8.627-216.0	1	PIN, ROLL 1/8 X 1 SS		
13	9.804-137.0	1	GASKET, SKIMMER BASE		
14	8.636-177.0	3	WASHER, 1/4 FLT SS		
15	8.913-732.0	1	OIL SKIMMER, SMALL		
-	8.922-839.0	1	WLMT, OIL SKIMMER, SMALL, SS		
16	8.627-929.0	3	WASHER,#10 FLAT W/NEOPRENE		
17	8.627-099.0	4	NUT, 10-32 HEX NYLOCK SS		

**Filter Option 8.642-689.0, 8.642-690.0**

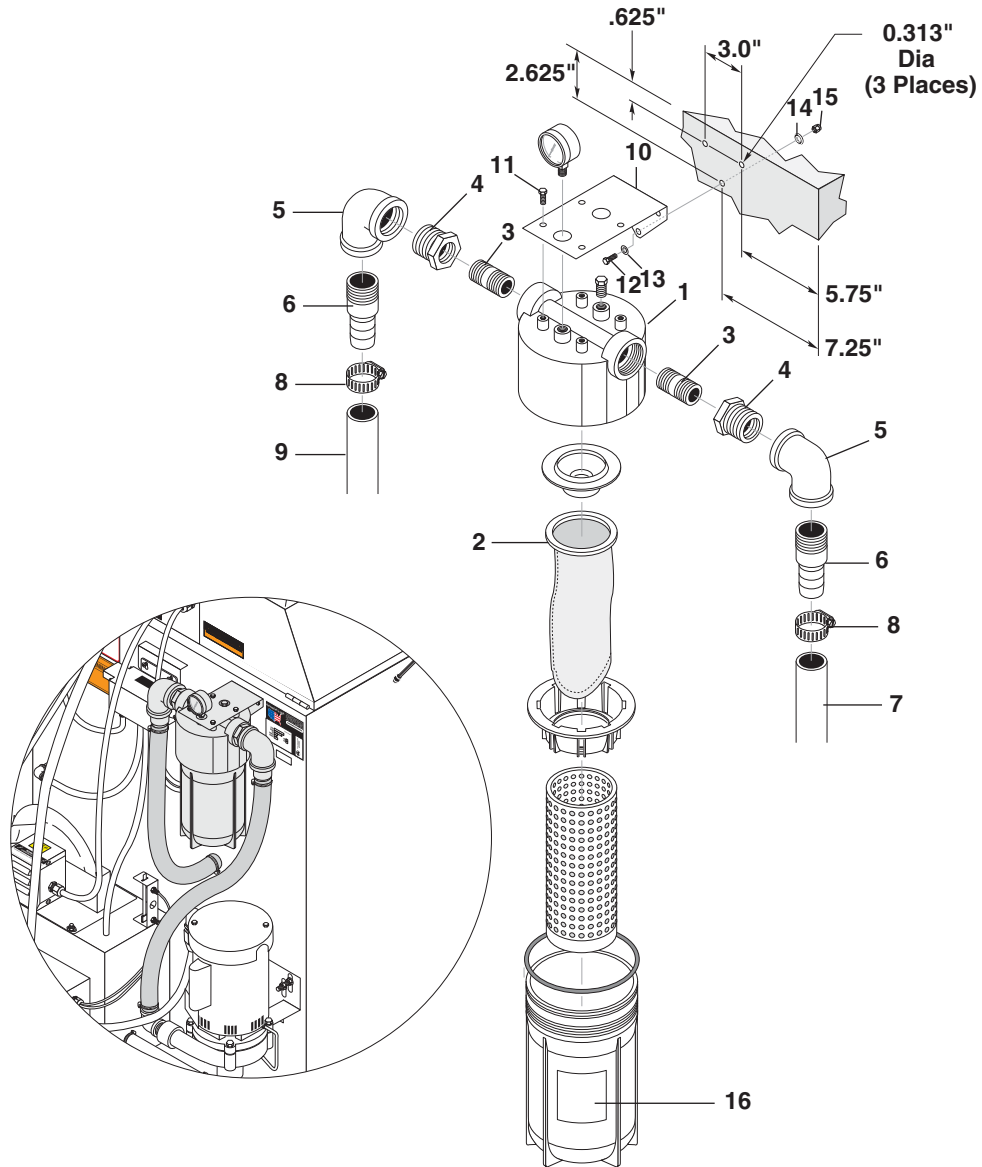

**Filter Option 8.642-689.0, 8.642-690.0**

REF	PART NO.	QTY	DESCRIPTION	SERIAL NO. FROM	NOTES
1	8.724-071.0	1	FILTER HOUSING 4" X 10" W/PSI GAUGE		
2	8.724-073.0	1	BAG, FILTER, 4" X 10", POLYESTER MESH, 200 MIC		
3	8.724-081.0	2	NIPPLE, 1" X 2-1/2" SCH40 GALV		
-	8.642-696.0	2	NIPPLE, 1" X 2-1/2" SCH 40 SS		
4	8.706-048.0	2	BUSHING, PIPE 1-1/4" X 1" NPT GALV		
-	8.706-288.0	2	BUSHING 1' X 1-1/4' STAINLESS		
5	8.706-198.0	2	ELBOW, 1-1/4" FEMALE, 90 ° GALV		
-	8.754-074.0	2	ELBOW, 1-1/4, 90 DEG, 304 S/S		
6	8.706-341.0	2	PIPE, BARBED MALE NPT 1-1/4" GALV		
-	9.804-198.0	2	PIPE BARBED/MALE NPT 1 1/4" STAINLESS		
7	8.724-082.0	1	HOSE, 1-14" X 25" 200 PSI		
8	8.617-725.0	4	CLAMP, HOS#24 1-1/16MIN 2		
9	9.804-244.0	1	HOSE, 1-1/4" X 14-1/2" 200 PSI		
10	8.930-052.0	1	BRACKET, FILTER 2412		
11	8.627-494.0	4	SCREW, 1/4-20 X .75 PHTF		
12	8.627-378.0	3	SCREW, 1/4-20 X .75 HHCS SS NP		
13	8.636-177.0	3	WASHER, 1/4 FLT SS		
14	8.627-961.0	3	WASHER, 1/4 SEG SS		
15	8.600-581.0	3	NUT, 1/4-20 HEX NYLOCK SS		
16	8.642-380.0	1	LABEL, CAUTION, FILTER PRESSURE		

# Electrical Panel 115V

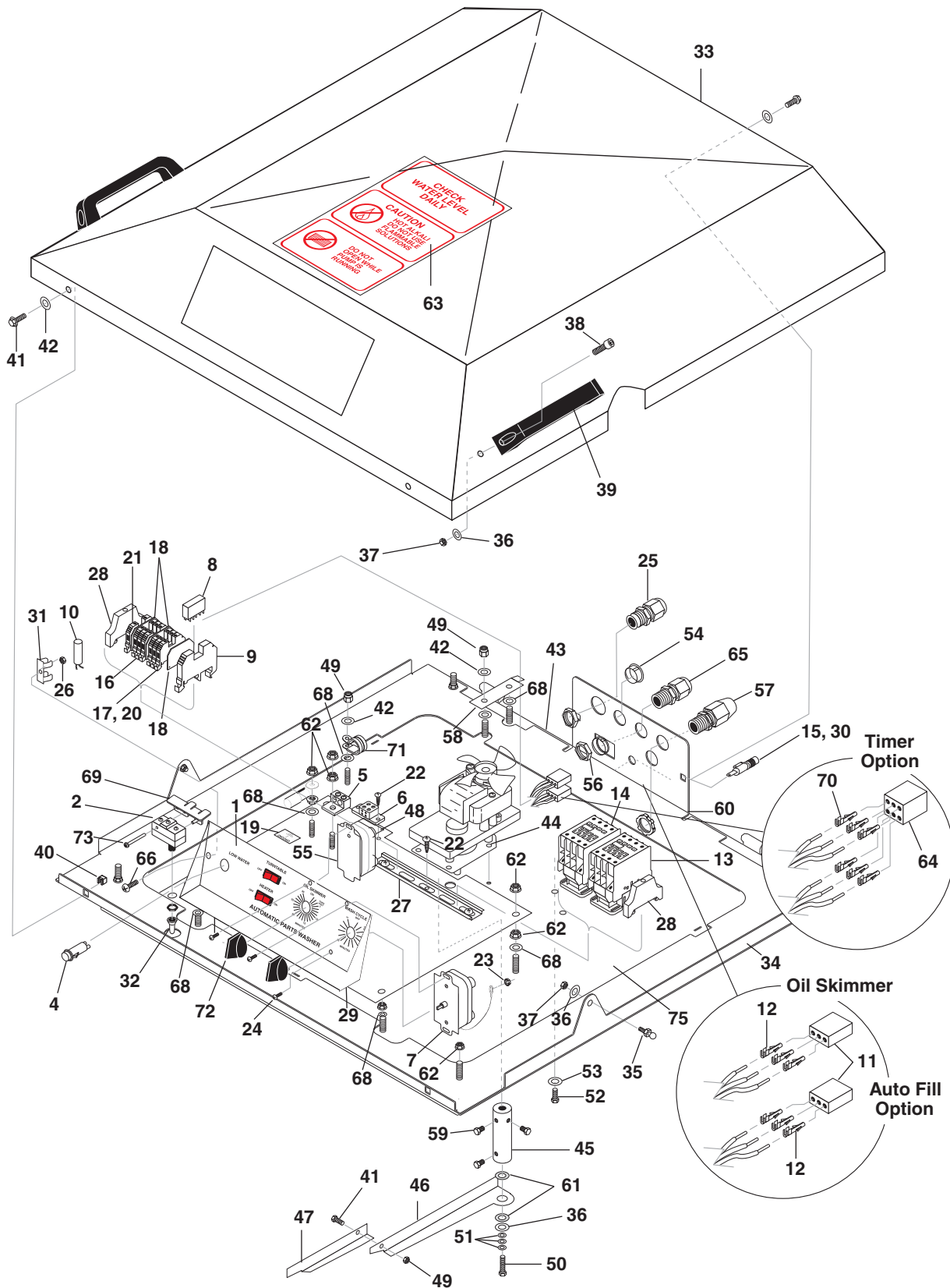

**Electrical Panel 115V**

REF	PART NO.	QTY	DESCRIPTION	SERIAL NO. FROM	NOTES
1	8.642-372.0	1	LABEL, CONTROL H20-2412, SC-2412D 115V		
2	9.804-510.0	1	SWITCH, LID/DOOR, 15 AMP, NON ENCLOSED		
3	8.713-328.0	2	SWITCH-LIGHTED ROCKER SKIMMER/ TT ON/OFF		
4	8.716-408.0	1	LIGHT, INDICATOR AMBER 120V		
5	8.713-086.0	1	GROUND-LUG 2 HOLE ALUM		
6	8.714-164.0	1	TERMINAL BLOCK - 2 POSITION (SURFACE) BL-BL		
7	8.756-487.0	1	TIMER, 15 MIN, SPRING WOUND		
8	8.753-367.0	1	RELAY, SPDT		
9	8.753-368.0	1	RELAY BASE		
10	8.713-315.0	1	SWITCH-MERCURY TILT		
11	8.713-603.0	2	CONNECTOR, ELECTRICAL 3 PIN MALE		
12	8.713-604.0	6	CONNECTOR, ELEC PIN FEM		
13	8.750-866.0	1	CONTACTOR, 3 POLE 9 AMP (PUMP)		
-	8.750-869.0	1	S CONTACT, NC AUX, FRONT MNT		NOT SHOWN
14	8.750-864.0	1	CONTACTOR, 3 POLE 16 AMP (HEATER)		
15	8.716-224.0	1	HOLDER, FUSE BLOCK PANEL MT		
16	8.716-398.0	3	TERMINAL BLOCK, BLUE, ENTRELEC, 125116-01		
17	8.716-396.0	3	TERMINAL BLOCK, ENTRELEC, GRAY 115-116-07 M4/6		
18	8.716-399.0	3	END COVER, ENTRELEC, GRAY 11836816 P-ON		
19	8.624-504.0	1	LABEL, GROUND SYMBOL		
20	8.755-017.0	1	TERMINAL BLOCK JUMPER, 3 POLE		
21	8.716-599.0	1	TERMINAL GRND, GREEN W/YELLOW		
22	8.627-435.0	2	SCREW, 10-24 X .5 PHPNHTC		
23	8.600-570.0	2	NUT, 10-32 HEXSTRW LK STL ZNPLT		
24	8.627-395.0	4	SCREW, 6-32 X .5 PHPNHMS SS		
25	9.802-518.0	1	STRAIN RELIEF, LT, STR,3/4" NPT .49-.71D		
26	8.600-576.0	1	NUT, 6-32 HEXSTRW LK STL ZNPLT		
27	8.643-037.0	1	DIN RAIL 35MM CUT		7.5"
28	9.804-595.0	1	END BRACKET, ENTRELEC		
29	8.913-729.0	1	CONTROL PANEL		
30	8.714-836.0	1	FUSE, 3 AMP		
31	8.713-316.0	1	CLIP, MOUNTING (FOR MERC. TILT SW)		
32	8.713-105.0	1	SWITCH BOOT, THREADED		
33	8.913-711.0	1	LID COVER 2412		
34	8.643-568.0	1	LID TOP 2412	7*	
35	9.804-207.0	2	BALL STUD, 5/16"-18 UNC, 10MM 2A STUD		

## Electrical Panel 115V

REF	PART NO.	QTY	DESCRIPTION	SERIAL NO. FROM	NOTES
36	8.601-067.0	7	WASHER, 5/16 FLT SS		
37	8.627-083.0	6	NUT, 5/16-18 HEX NYLOCK SS		
38	8.627-721.0	4	SCREW, 5/16-18 X 1 SCHCS SS		
39	9.804-203.0	2	HANDLE, DOOR/STRAINER		
40	9.802-793.0	4	NUT, CAGE, 1/4" X 16 GA		
41	8.627-378.0	5	SCREW, 1/4-20 X .75 HHCS SS NP		
42	8.636-177.0	10	WASHER, 1/4 FLT SS		
43	8.714-379.0	1	GEARMOTOR, AC6 RPM 120V, 1/2" SS SHAFT		
44	9.804-247.0	1	GASKET, GEARMOTOR PAPER FIBERFLEX		
45	8.714-380.0	1	TORQUE, HUB OUTLAW		
-	8.923-359.0	1	TORQUE, HUB, SS		
46	8.913-712.0	1	TORQUE ARM		
-	8.923-024.0	1	ARM, TORQUE, ROTATION ARM		
47	8.913-713.0	1	TIP TORQUE, ROTATION ARM		
-	8.923-023.0	1	TIP TORQUE, ROTATION ARM, SS		
48	8.642-385.0	1	LABEL, 120V		
49	8.600-581.0	5	NUT, 1/4-20 HEX NYLOCK SS		
50	8.642-529.0	1	SCREW, 5/16-24 X 2 HHMS SS		
51	8.642-528.0	3	WASHER, 5/16 X .625 X .047, DSP SS		
52	8.642-541.0	4	SCREW, #10-32 X .5 HHSERFLGMS SS		
53	8.627-929.0	4	WASHER,#10 FLAT W/NEOPRENE		
54	9.802-105.0	2	PLUG, 7/8" HOLE		
55	8.756-488.0	1	TIMER, 30 MIN, SPRING WOUND		
56	9.802-525.0	1	LOCKNUT, 1/2" 8463		
57	8.716-547.0	1	CONNECTOR, 1/2" L/T STRAIGHT		
58	8.913-749.0	1	LID, HINGE STOP		
59	8.725-303.0	3	SCREW, 1/4"-28 X 5/8" LG HEX HD SS		
60	8.642-403.0	1	LABEL, HOUR METER		NOT SHOWN
61	8.637-584.0	2	WASHER, 3/8 X .625 X .063 THR		
62	8.627-137.0	14	NUT, 1/4-20 SERFLG STL ZNPLT		
63	8.642-402.0	1	LABEL, CAUTION CHECK WATER LEVEL		
64	8.713-731.0	1	CONNECTOR, ELECTRICAL PIN MALE		
65	9.802-515.0	1	STRAIN RELIEF LQ TITE		
66	8.600-662.0	1	SCREW, 6-32 X .25 PHPNHMS SS		
67	8.642-431.0	1	HARNESS, 2412, 115V		NOT SHOWN
68	8.627-961.0	9	WASHER, 1/4 SEG SS		
69	8.642-801.0	1	COVER, LIMIT SWITCH		
70	8.713-768.0	6	CONNECTOR, ELECTRICAL PIN MALE		
71	8.623-341.0	2	CLAMP, 3/4 DIA CUSHION .406DIA		
72	8.756-586.0	2	KNOB, TIMER, SPRING WOUND		

REF	PART NO.	QTY	DESCRIPTION	SERIAL NO. FROM	NOTES
73	8.627-471.0	1	SCREW, 6-32 X 1 PHPNHMS STL ZNPLT		
74	8.642-887.0	1	CORD SET 12/3 STOOW, 8 FT, BLK		NOT SHOWN
75	8.643-566.0	1	LID PAN ASSEMBLY 2412	7*	

# Electrical Panel 208V, 230V

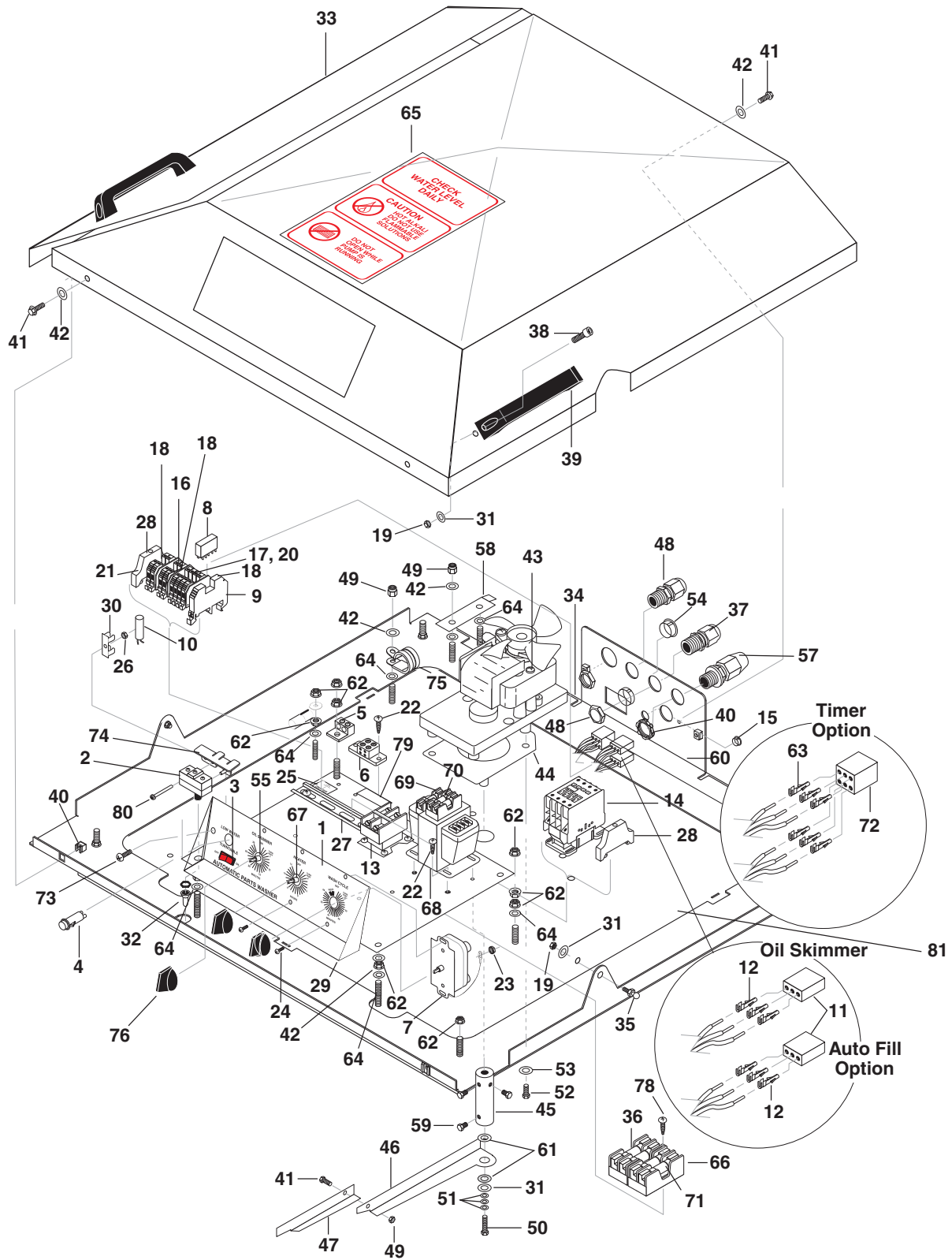



**Electrical Panel 208V, 230V**

REF	PART NO.	QTY	DESCRIPTION	SERIAL NO. FROM	NOTES
1	8.642-373.0	1	LABEL, CONTROL, H2O-2412, 230V		
2	9.804-510.0	1	SWITCH, LID/DOOR, 15 AMP NON ENCLOSED		
3	8.713-328.0	1	SWITCH, LIGHTED ROCKER SKIMMER/TT ON/OFF		
4	8.716-408.0	1	LIGHT, INDICATOR AMBER 120V		
5	8.713-086.0	1	GROUND, LUG 2 HOLE ALUM		
6	8.714-164.0	1	TERMINAL BLOCK, 2 POS (SURFACE) BL-BL		
7	8.756-489.0	1	TIMER, 60 MIN, SPRING WOUND		
8	8.753-367.0	1	RELAY, SPDT		
9	8.753-368.0	1	RELAY, BASE		
10	8.713-315.0	1	SWITCH-MERCURY TILT		
11	8.713-603.0	2	CONNECTOR, ELECTRICAL 3 PIN MALE		
12	8.713-604.0	6	CONNECTOR, ELECTRICAL PIN FEM		
13	8.714-290.0	1	CONTACTOR, GEN PURPOSE, 2 POLE 230V, 30 AMP		
14	8.750-866.0	1	CONTACTOR, 3 POLE, 9 AMP		
15	8.714-839.0	1	PLUG, PLASTIC BLACK 1/2"		
16	8.716-398.0	3	TERMINAL BLOCK, BLUE ENTRELEC 125116-01		
17	8.716-396.0	3	TERMINAL BLOCK, ENTRELEC, GRAY 115-116-07 M4/6		
18	8.716-399.0	3	END COVER, ENTRELEC, 11836816 P-ON GRAY		
19	8.627-083.0	6	NUT, 5/16-18 HEX NYLOCK SS		
20	8.755-017.0	1	TERMINAL BLOCK JUMPER, 3 POLE		
21	8.716-599.0	2	TERMINAL, GROUND, GREEN/YELLOW		
22	8.627-435.0	12	SCREW, 10-24 X .5 PHPNHTC		
23	8.600-570.0	3	NUT, 10-32 HEXSTRW LK STL ZNPLT		
24	8.627-395.0	6	SCREW, 6-32 X .5 PHPNHMS SS		
25	8.624-504.0	1	LABEL, GROUND SYMBOL		
26	8.600-576.0	1	NUT, 6-32 HEXSTRW LK STL ZNPLT		
27	8.643-037.0	1	DIN RAIL 35MM CUT		7.5"
28	9.804-595.0	1	END BRACKET, ENTRELEC		
29	8.941-092.0	1	CONTROL PANEL		
30	8.713-316.0	1	CLIP, MOUNTING		
31	8.601-067.0	7	WASHER, 5/16 FLT SS		
32	8.713-105.0	1	SWITCH BOOT, THREADED		
33	8.913-711.0	1	ASSY, LID COVER 2412		
34	8.643-568.0	1	LID TOP 2412	7*	
35	9.804-207.0	2	BALL STUD 5/16"-18 UNC 10 MM 2A STUD		
36	8.713-287.0	2	FUSE, 12 AMP		
37	9.802-515.0	1	STRAIN RELIEF, STRT, LQ TITE		

## Electrical Panel 208V, 230V

S

REF	PART NO.	QTY	DESCRIPTION	SERIAL NO. FROM	NOTES
38	8.627-721.0	4	SCREW, 5/16-18 X 1 SCHCS SS		
39	9.804-203.0	2	HANDLE, DOOR/STRAINER		
40	9.802-793.0	4	NUT, CAGE, 1/4" X 16 GA		
41	8.627-378.0	5	SCREW, 1/4-20 X .75 HHCS SS NP		
42	8.636-177.0	10	WASHER, 1/4 FLT SS		
43	8.714-379.0	1	GEARMOTOR, AC FRACT 6 RPM 2412 DRIVE 120V 1/2" SS SHAFT		
44	9.804-247.0	1	GASKET, GEARMOTOR PAPER FIBERFLEX		
45	8.714-380.0	1	TORQUE HUB, OUTLAW		
-	8.923-359.0	1	TORQUE HUB, SS		
46	8.913-712.0	1	TORQUE ARM		
-	8.923-023.0	1	ARM,TORQUE ROTATION ARM		
47	8.913-713.0	1	TIP TORQUE ROTATION ARM		
-	8.923-023.0	1	TIP TORQUE ROTATION ARM, SS		
48	9.802-518.0	1	STRAIN RELIEF, LT, STR, 3/4" NPT .49-.71D		
49	8.600-581.0	5	NUT, 1/4-20 HEX NYLOCK SS		
50	8.642-529.0	1	SCREW, 5/16-24 X 2 HHMS SS		
51	8.642-528.0	3	WASHER, 5/16 X .625 X .047, DSP SS		
52	8.642-541.0	4	SCREW, #10-32 X .5 HHSERFLGMS SS		
53	8.627-929.0	4	WASHER,#10 FLAT W/NEOPRENE		
54	9.802-105.0	2	PLUG, 7/8" HOLE		
55	8.756-488.0	1	TIMER, 30 MIN, SPRING WOUND		
56	9.802-525.0	1	LOCKNUT, 1/2" 8463		
57	8.716-547.0	1	CONNECTOR, 1/2" L/T STRAIGHT		
58	8.913-749.0	1	LID, HINGE STOP		
59	8.725-303.0	3	CAPSCREW, 1/4-28 X 5/8" SS		
60	8.642-403.0	1	LABEL, HOUR METER		NOT SHOWN
61	8.637-584.0	2	WASHER, 3/8 X .625 X .063 THR		
62	8.627-137.0	14	NUT, 1/4-20 SERFLG STL ZNPLT		
63	8.713-768.0	6	CONNECTOR, ELECTRICAL PIN MALE		
64	8.627-961.0	9	WASHER, 1/4 SEG SS		
65	8.642-402.0	1	LABEL, CAUTION, CHECK WATER LEVEL		
66	8.713-290.0	2	FUSE BLOCK (H2PR) 2 POLE		
67	8.756-490.0	1	TIMER, 12 HOUR, SPRING WOUND		
68	8.716-875.0	1	TRANSFORMER, 200VA, 230-460V/115V		
-	8.716-895.0	1	TRANSFORMER, 200VA, 208V		
69	8.713-078.0	1	FUSE, 2 AMP FNM-2		
70	8.713-286.0	2	FUSE, CLASS 2 AMP		
71	8.713-369.0	2	FUSE, 25 AMP		
72	8.713-731.0	1	CONNECTOR, ELECL, 6-PIN FEM		
73	8.600-662.0	1	SCREW, 6-32 X .25 PHPNHMS SS		
74	8.642-801.0	1	COVER, LIMIT SWITCH		
75	8.623-341.0	2	CLAMP, 3/4 DIA CUSHION .406DIA		

**Electrical Panel 208V, 230V**

REF	PART NO.	QTY	DESCRIPTION	SERIAL NO. FROM	NOTES
76	8.756-586.0	3	KNOB, TIMER, SPRING WOUND		
77	8.642-432.0	1	HARNESS, 2412, 208-230V		1/2 HP, NOT SHOWN
-	8.642-465.0	1	HARNESS, 2412, 208-230V 1PH 2HP		2 HP, NOT SHOWN
78	8.642-578.0	4	SCREW, #8-18 X.50 PHRDHSMS SS		
79	8.642-374.0	1	LABEL 208V 1PH		
-	8.642-391.0	1	LABEL 230V 1PH		
80	8.627-471.0	1	SCREW, 6-32 X 1 PHPNHMS STL ZNPLT		
81	8.643-566.0	1	LID PAN ASSEMBLY 2412	7*	



<b>Ref. #</b>	<b>Model: Serial #</b>
1	100435400000007
2	10435400000017, 10435410000006, 10435420000003, 10435430000002, 10435440000001, 10435450000002, 10435460000001, 10435470000001, 10435480000001, 10435490000001
3	10435400000018, 10435410000007, 10435420000003, 10435430000002, 10435440000001, 10435450000002, 10435460000001, 10435470000001, 10435480000001, 10435490000001
4	10435400000038, 10435410000008, 10435420000006, 10435430000003, 10435450000002
5	10435400000056, 10435410000010, 10435420000010, 10435430000004, 10435440000001, 10435450000002, 10435460000001, 10435470000001, 10435480000001, 10435490000001, 10435500000002, 10435510000002, 10435520000001, 10435530000001, 10435540000001, 10435550000002, 10435560000001, 10435570000001, 10435580000001, 10435590000001, 10435600000001, 10435610000001, 10435620000001, 10435630000001
6	10435400000066, 10435410000010, 10435420000012, 10435430000004, 10435440000001, 10435450000002, 10435460000001, 10435470000001, 10435480000001, 10435490000001
7	10435460000001, 10435470000001, 10435420000017, 10435400000123, 10435410000013, 10435430000006, 10435430000006, 10435450000002, 10435440000001, 10435480000002, 10435490000002

